

SIMTEK

Werkzeuge
für **höchste**
Anforderungen

Hauptkatalog Main Catalog

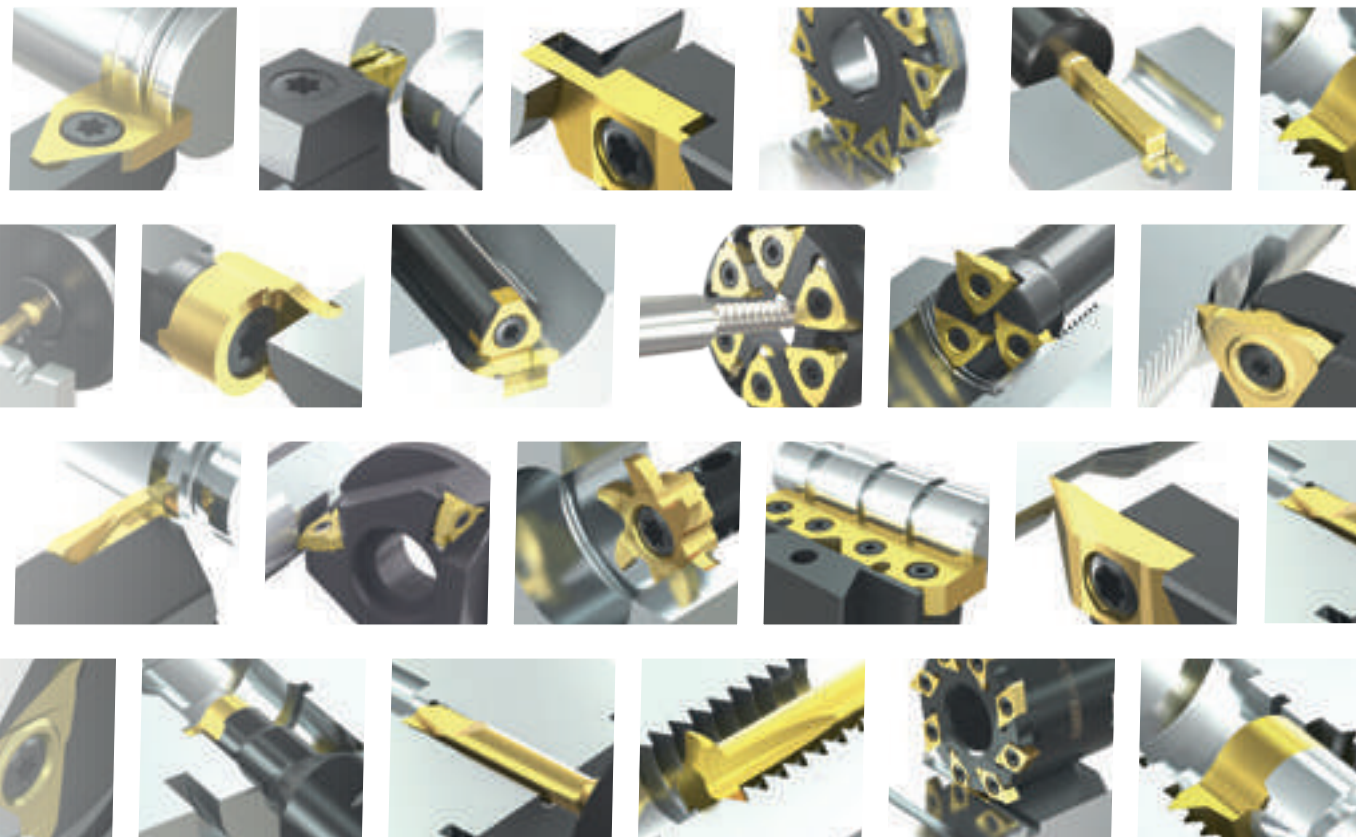


EDITION
R21DE
UPDATE 1



Hauptkatalog // Main Catalog

EDITION
R21DE
UPDATE 1



Drehen
Turning

Zirkularfräsen
Groove Milling

Nutstoßen
Broaching

Mehrkantfräsen
Polygon Milling

Gewindewirbeln
Thread Whirling

Besuchen Sie uns auch im Internet
Please visit us online

www.simtek.com



Bei der Papierauswahl haben wir uns bewusst für ein FSC-zertifiziertes Papier entschieden.
FSC steht für eine nachhaltige, ökologische und sozial verantwortliche Nutzung der Wälder.

We have specifically chosen FSC-Certified paper only.
FSC stands for sustainable, ecological and socially responsible use of forest

Hauptkatalog // Main Catalog

Drehen
Turning

Zirkularfräsen
Groove Milling

Nutstoßen
Broaching

Mehrkantfräsen
Polygon Milling

Gewindewirbeln
Thread Whirling

simturn
SIMTEK TURNING TOOLS

8

simmill
SIMTEK MILLING TOOLS

434

simcut
SIMTEK CUTTING TOOLS

655

Seite // Page

SIMTEK Präzisionswerkzeuge GmbH
Christophstraße 18
DE-72116 Mössingen

SIMTEK Präzisionswerkzeuge GmbH ist zertifiziert nach ISO 9001:2015 und ISO 14001:2015. Mehr Informationen finden Sie unter www.simtek.com

SIMTEK Präzisionswerkzeuge GmbH is certified to ISO 9001:2015 and ISO 14001:2015. Further information can be found on www.simtek.com

fon +49 7473 9517 - 100
fax +49 7473 9517 - 77
mail sales@simtek.com
web www.simtek.com

Weitere Kontaktinfos finden Sie auf Seite **736**
Contact information can be found on page **736**

Neue Produktgruppe // New Product group

simturnPX

SIMTEK small part machining type PX



Ausdrehen
neu erfunden. Boring
reinvented.

ab Seite 218 // as of Page 218

Neue Produktgruppe // New Product group

simmillPMX

SIMTEK milling tools type PMX

ab Seite // as of Page 477

Dreischneidige Frässchneidplatten in verschiedenen Größen für das Sicherungsringnutenfräsen, Schlitzfräsen sowie Gewindefräsen in Bohrungen zwischen Ø7,0 mm und Ø11,0 mm.

Three edged milling inserts in different sizes for circlip ring groove milling, slot milling and thread milling in bores between Ø 7,0 mm and Ø 11,0 mm.

Weitere ausgewählte Neuheiten // Further selected news

simturnAX

SIMTEK small part machining type AX

ab Seite // as of Page 16

Ausdrehwerkzeuge für die Hartbearbeitung mit SIMTEK CBN – Schneidstoff jetzt bereits ab Bohrungsdurchmesser 1,0 mm.

Boring inserts for hard part turning applications with SIMTEK CBN – grade now starting at a minimum bore diameter of 1,0 mm.

Erweiterung um Schneideinsätze für das Axialstechen ab Nutinnendurchmesser 3,0 mm.

Range extension by inserts for face grooving applications starting at inner groove diameter 3,0 mm.

simturnK2

SIMTEK small part machining type K2

ab Seite // as of Page 253

Schnellwechsellköpfe geeignet für die Schnellwechselsysteme „Swiss Micro“ von Swisstools und „PZturn“ der Firma MAS.

Toolholders suitable for the quick-change systems „Swiss Micro“ by Swisstools and „PZturn“ by the company MAS.

simcutBA|BF

SIMTEK broaching type BA|BF

ab Seite // as of Page 659

Neue Trägerwerkzeuge für das Nutstoßen von Standard- und Sonderprofilen auf Nutstoßaggregaten „Benz LinA 4.0“ und „EWS P20“, sowie neue Schneidwerkzeuge für das Stoßen von Längsnuten nach Inch-Norm.

New toolholders for broaching of standard and special profiles on broaching units „Benz LinA 4.0“ and „EWS P20“, as well as cutting tools for keyway broaching according to inch standards.

Inch-Abmessungen **inch**

Zudem wurde der SIMTEK Hauptkatalog durch alle Produktgruppen hindurch um eine Vielzahl an Werkzeugen mit Inch-Abmessungen ergänzt. Sie erkennen diese an dem Zusatz „inch“ rechts neben den Maßtabellen der Katalogseiten.

Inch dimensions **inch**

In addition, the SIMTEK main catalog has been extended by a large number of tools with inch dimensions for all product groups. You can recognize these by the addition „inch“ to the right of the dimension tables of the catalog pages.



Made by SIMTEK. Made for you.

Eine neue Schneidstoffgeneration für SIMTEK Präzisionswerkzeuge: Von SIMTEK entwickelt und im Haus gefertigt, um höchsten Anforderungen zu entsprechen.

GRADIUM-Schneidstoffe stehen für ein ideales Zusammenspiel aus Hartmetallsubstrat, Schneidenveredelung und Verschleißschutzbeschichtung. Sie stehen auch für eine gleichbleibende Prozessgüte und hohe Qualität, die wir durch haus-eigene Beschichtungsanlagen und Fertigungsprozesse gewährleisten können. Die Verkettung der einzelnen Fertigungsschritte im Haus bietet darüber hinaus noch kürzere Produktionszeiten und logistische Vorteile.


**GRADIUM Hochleistungs-Schneidstoffe:
Gemacht für Ihren Erfolg.**

A new generation of high performance grades for SIMTEK precision tools: Designed and made by SIMTEK in order to meet highest expectations.

GRADIUM cutting grades stand for an ideal combination of carbide substrate, cutting edge finish and high performance coatings. They also stand for process reliability and high quality, which is one of the results of adding the coating production to the rest of the manufacturing processes we already do inhouse. This chain of manufacturing processes also provides even shorter production times and logistical advantages.

**GRADIUM high performance grades:
Made for your success.**

GRADIUM X8

 Unser goldfarbener Allround-Schneidstoff
Our gold-colored allround cutting grade

Unsere erste Wahl. Für die meisten Materialien.
Our first choice. For most materials.



Multilayer TiAlN + TiN-Deckschicht | Anwendungsspezifisches Hartmetall | Engste Schichtdickentoleranz
Multilayer TiAlN + TiN-Cover | Application-specific carbide | Narrow coating thickness tolerance

GRADIUM X4 & GRADIUM X6

Zwei Drehspezialisten für rostfreie Stähle und NE-Metalle.
Two specialists for turning in stainless steel and non-ferrous metal.

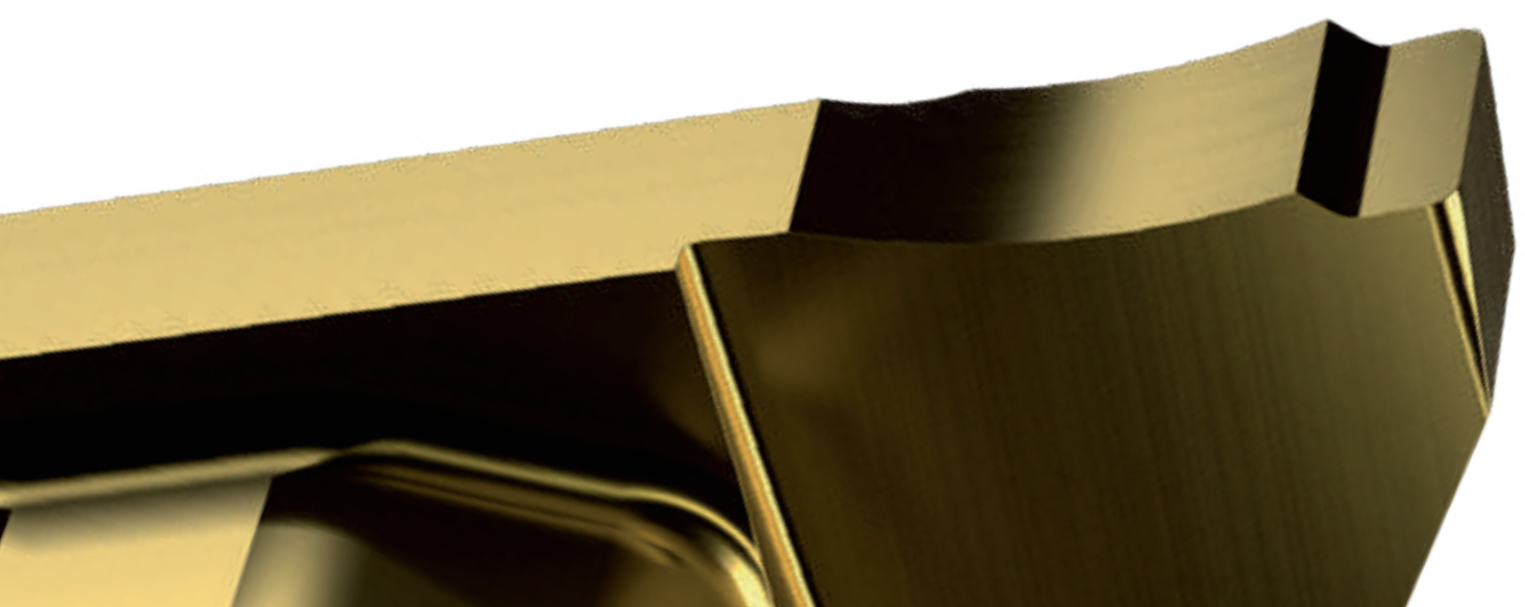


Multilayer TiAlN | Anwendungsspezifisches Hartmetall | Engste Schichtdickentoleranz
Multilayer TiAlN | Application-specific carbide | Narrow coating thickness tolerance



GRADIUM X4 ist optimiert für Werkzeugsysteme und Anwendungen mit üblicherweise niedrigen bis mittleren Vorschüben, während GRADIUM X6 für Werkzeugsysteme und Anwendungen mit üblicherweise mittleren bis hohen Vorschüben optimiert ist. *

GRADIUM X4 is optimized for tool systems and applications where low to medium feed rates are common, while GRADIUM X6 was optimized for tool systems and applications where medium to high feed rates occur. *



* Die jeweils empfohlene Variante ist abhängig vom Werkzeugsystem und der Anwendung. Der Katalogseitenspalte „Unsere erste Wahl“ und dem Webcodetool (www.simtek.com) können Sie die jeweils empfohlene Variante entnehmen.

The recommended variant depends on the tool system and the application. Please refer to the catalog page column „Our first choice“ or check our webcode tool (www.simtek.com) for recommended variants.



Entdecken Sie unsere **digitalen Services.** Discover our **digital services.**

Mit den digitalen Diensten von SIMTEK bieten wir eine Vielzahl an Funktionen und Möglichkeiten, welche Sie bequem und einfach rund um die Uhr und jederzeit nutzen können.

With SIMTEK's digital services, we offer numerous functions and possibilities! Conveniently and easily usable - around the clock and from anywhere in the world!



Der **SIMTEK Produktkonfigurator.** The **SIMTEK Product Configuration Service.**

Mit diesem Online-Service haben Sie jetzt die Möglichkeit, kundenspezifische Werkzeuge nach Ihren Bedürfnissen zu konfigurieren und hierfür ein verbindliches Angebot zu erhalten. // This online service offers you the possibility to configure customer-specific tools according to your needs and to get a binding offer for your configured tool – anytime, anywhere!

Flexibilität und Sicherheit **Flexibility and security**



Der SIMTEK-Produktkonfigurator ist über unsere Website www.simtek.com für zuvor registrierte Kunden rund um die Uhr und von jedem Browser der Welt aus zugänglich.

The SIMTEK Product Configuration Service is accessible via our website www.simtek.com for previously registered customers around the clock and from any browser in the world.

Einfach zu bedienen **Easy-to-use**



Mithilfe eines geführten Frage/Antwort-Ablaufs, führt Sie der SIMTEK-Produktkonfigurator gezielt und Schritt für Schritt zum gewünschten Werkzeug.

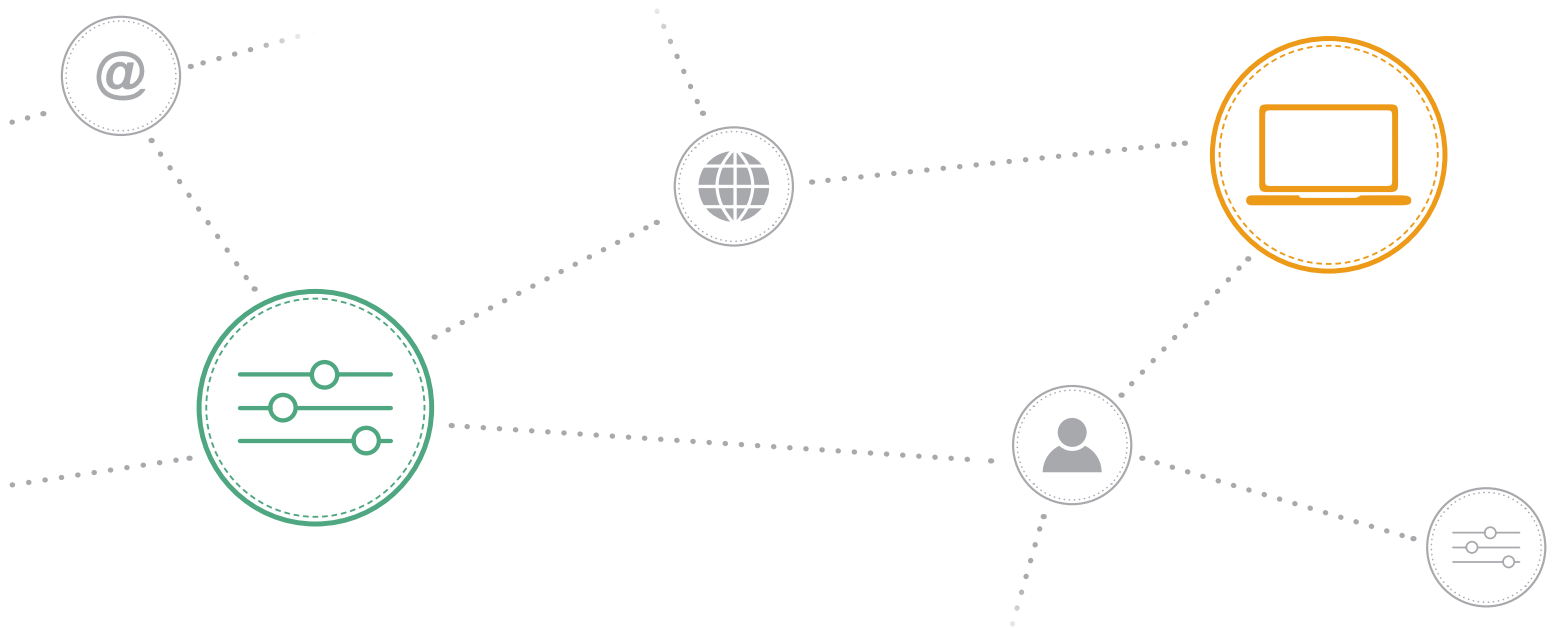
Using a guided question/answer process, the SIMTEK Product Configuration Service guides you step-by-step to the desired tool.

Live Angebot **Live offer**



Schließlich erhalten Sie eine Live-Vorschau auf den Preis Ihres konfigurierten SIMTEK-Werkzeugs, können die Staffelmengen anpassen und sich das Angebot per Mail zusenden lassen.

In a live preview, you already get an online preview of the price for your individually configured SIMTEK tool. In addition, you can adjust scale quantities directly online to your requirements. As soon as you have completed your offer, you will also receive your written offer by e-mail in your mailbox shortly afterwards.



Der **SIMTEK Tool Designer.** The **SIMTEK Tool Designer.**

Mit dem SIMTEK Tool Designer können Sie SIMTEK Standardträgerwerkzeuge schnell und unkompliziert an Ihren individuellen Bedarf anpassen. // With the SIMTEK Tool Designer, you now have the possibility to adjust SIMTEK standard toolholders to your individual needs.

Trägerwerkzeug auswählen Choose toolholder



Geben Sie das zu konfigurierende SIMTEK Standardträgerwerkzeug in das Eingabefeld ein. Sie erhalten direkt mit der Eingabe eine vorgefilterte Liste der Trägerwerkzeuge aus dem SIMTEK Standardsortiment zur Verfügung.

Enter the SIMTEK standard toolholder you would like to adjust into the entry field. The SIMTEK Tool Designer offers you a prefiltered list of adjustable SIMTEK toolholders.

Anpassungen vornehmen Make your adjustments



Im nächsten Schritt erhalten Sie eine Auswahl an möglichen Anpassungen für Ihr gewähltes Werkzeug, welche Sie direkt online vornehmen können. Der SIMTEK Tool Designer zeigt Ihnen Ihre Möglichkeiten hierbei übersichtlich und verständlich auf.

In the next step you receive a selection of possible adjustments for your chosen tool, which can directly be made online. The SIMTEK Tool Designer shows you the possibilities in a clear and understandable way.

Überblick und Bestellung Overview and order



Abschließend erhalten Sie einen Überblick Ihrer Anpassungen sowie Preis- und Lieferzeiteninformationen. Zuvor registrierter Nutzer können das konfigurierte Trägerwerkzeug direkt über das SIMTEK Information Center bestellen.

Finally, you receive an overview of your chosen adjustments as well as price and delivery time information. Previously registered users can order the configured toolholder directly via the SIMTEK Information Center.



Der **SIMTEK Onlineshop.** The **SIMTEK Onlineshop.**

Mit dem SIMTEK Onlineshop haben Sie die Möglichkeit, Werkzeuge aus dem SIMTEK Standardsortiment sowie Ihre kundenspezifischen Individualwerkzeuge online zu bestellen. // With the SIMTEK Onlineshop, you now have the possibility to order tools from the SIMTEK standard range as well as your customized individual tools online.

1 Artikel auswählen Select items

2 Warenkorb prüfen Check cart

3 Bestellung aufgeben Complete cart

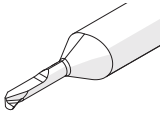
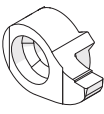
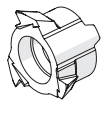
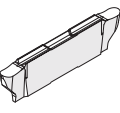
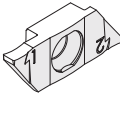
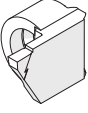
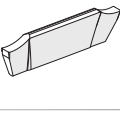
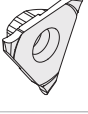
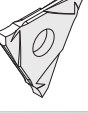
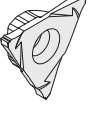
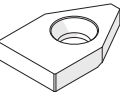
Der SIMTEK Onlineshop ist über unsere Website www.simtek.com für zuvor registrierte Kunden rund um die Uhr und von jedem Browser der Welt aus zugänglich. // The SIMTEK Onlineshop is accessible via our website www.simtek.com for previously registered customers around the clock and from any browser in the world.

simturn
SIMTEK TURNING TOOLS

Info

Die simturn Drehwerkzeuge The simturn Turning Tools

simturn AX
simturn DX
simturn PX
simturn H2
simturn K2
simturn C4
simturn GX
simturn E3
simturn E12
simturn FX
simturn Decolletage
simturn OA
Index

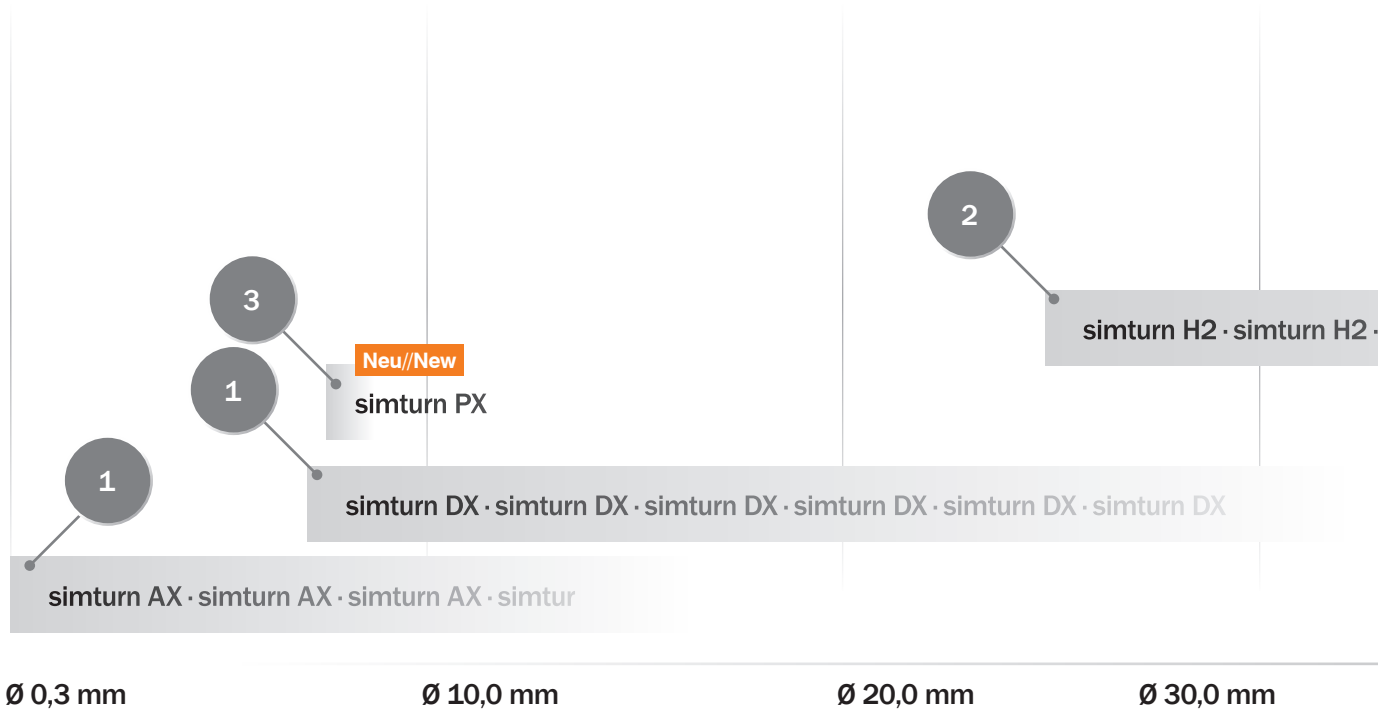
		Innenbearbeitung Internal applications	Außenbearbeitung External applications	Seite Page
simturnAX SIMTEK small part machining type AX		✓ Ø ≥ 0,3 mm		16
simturnDX SIMTEK small part machining type DX		✓ Ø ≥ 7,0 mm		146
simturnPX SIMTEK small part machining type PX	Neu//New 	✓ Ø ≥ 7,8 mm		218
simturnH2 SIMTEK small part machining type H2		✓ Ø ≥ 24,5 mm	✓ tmax 18,0 mm	226
simturnK2 SIMTEK small part machining type K2			✓ tmax 7,0 mm	253
simturnC4 SIMTEK small part machining type C4			✓ tmax 5,5 mm	274
simturnGX SIMTEK small part machining type GX		✓ Ø ≥ 38,0 mm	✓ tmax 26,0 mm	291
simturnE3 SIMTEK small part machining type E3		✓ Ø ≥ 41,0 mm	✓ tmax 5,0 mm	317
simturnE12 SIMTEK small part machining type E12		✓ Ø ≥ 46,0 mm	✓ tmax 8,0 mm	357
simturnFX SIMTEK small part machining type FX		✓ Für Individualwerkzeuge For customized tools	✓	391
simturnDecolletage SIMTEK Turning Tools Type Decolletage			✓	412

Info

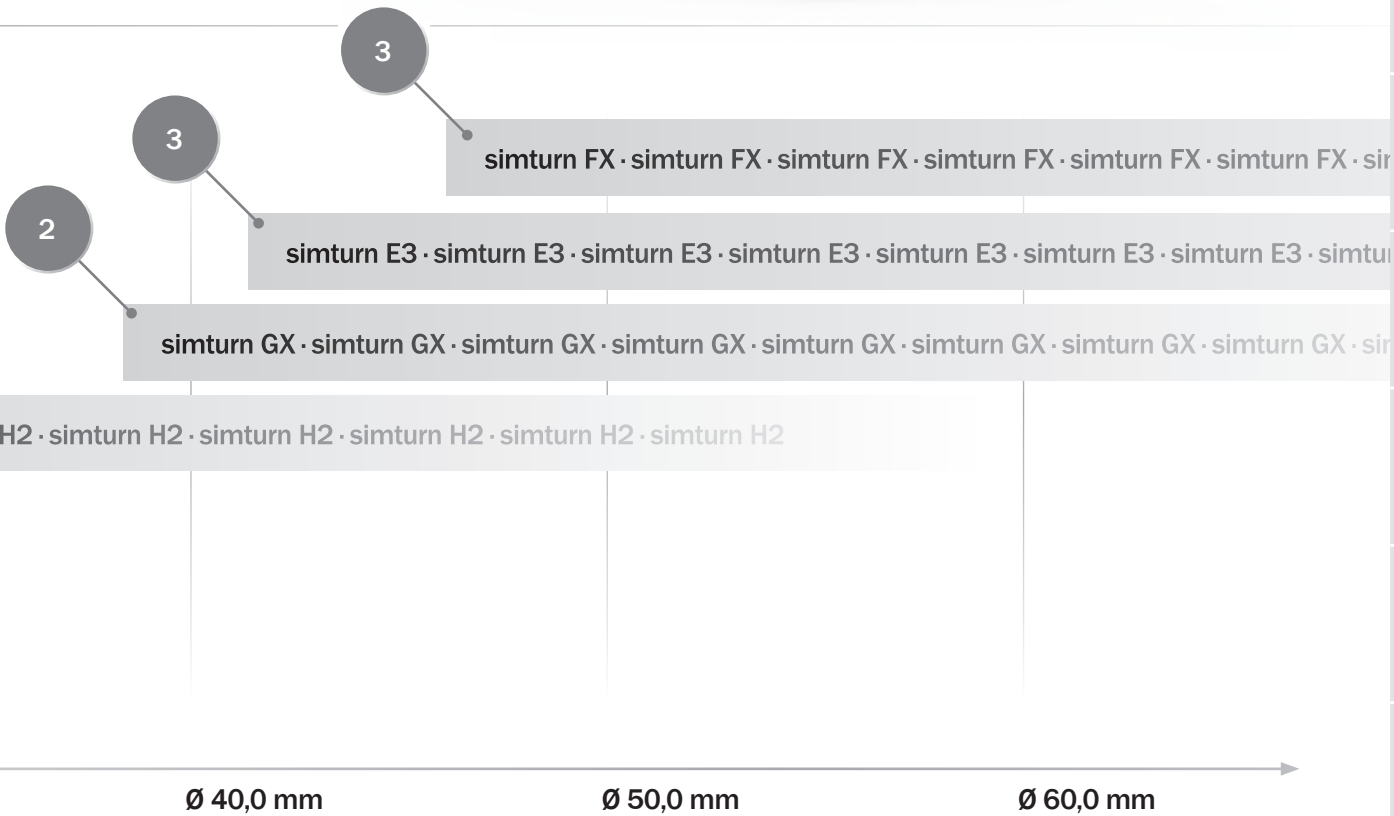
simturn Drehwerkzeuge für die Innenbearbeitung
simturn Turning Tools for Internal Applications

Werkzeugsysteme nach bearbeitbaren Bohrungsdurchmessern
Our tool systems and the machinable bore diameters

simturn AX	simturn DX	simturn PX	simturn H2	simturn GX	simturn E3	simturn FX
Seite // Page	Seite // Page	Seite // Page	Seite // Page	Seite // Page	Seite // Page	Seite // Page
16	146	218	226	291	317	391

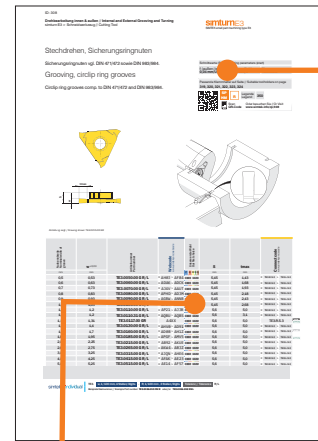


- 1 Werkzeugsystem mit einschneidiger Schneidplatte
Tool system with single edge cutting insert
- 2 Werkzeugsystem mit zweischneidiger Wendeschneidplatte
Tool system with two-edged indexable cutting insert
- 3 Werkzeugsystem mit dreischneidiger Wendeschneidplatte
Tool system with three-edged indexable cutting insert



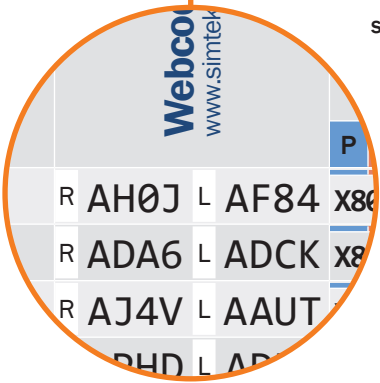
Zur Nutzung des Katalogs // Using the catalog

Zusätzliche Infos zu den Katalogseiten
Additional Information about the Catalog Pages



Der Webcode und Connectcode in jeder Katalogseitenzeile
The Webcode and Connectcode on every catalog page line

Nutrenbreite Nominal width of groove	w +0,03	Artikelnummer Part number	Webcode www.simtek.com/webcode	Unsere erste Wahl Our first choice	S	tmax	Connectcode www.simtek.com/code
mm	mm			K M N S	mm	mm	
0,5	0,53	TE3.0050.00 G R/L	R AH0J L AF84 X800	X800 X408	5,45	1,43	R TE3.R.5.3 L TE3.L.5.3
0,6	0,63	TE3.0060.00 G R/L	R ADA6 L ADCK X800	X808 X408	5,45	1,68	R TE3.R.5.3 L TE3.L.5.3
0,7	0,73	TE3.0070.00 G R/L	R AJ4V L AAUT X800	X808 X408	5,45	1,93	R TE3.R.5.3 L TE3.L.5.3
0,8	0,83	TE3.0080.00 G R/L	R APHD L ADJM X800	X408	5,45	2,18	R TE3.R.5.3 L TE3.L.5.3
0,9	0,93	TE3.0090.00 G R/L	R AQBW L ANNB X800	X408	5,45	2,43	R TE3.R.5.3 L TE3.L.5.3
1,1	1,2	TE3.0110.31 G R/L	R AQBW L AQB5 X800	X400	5,6	3,1	R TE3.R.5.3 L TE3.L.5.3
1,17	1,31	TE3.0117.00 GR	A4XX	X800 X400	5,6	5,0	TE3.R.5.3
1,3	1,4	TE3.0130.00 G R/L	R AHV0 L AD91 X800	X400	5,6	5,0	R TE3.R.5.3 L TE3.L.5.3
1,6	1,7	TE3.0160.00 G R/L	R AD0B L AH1Z X800	X400	5,6	5,0	R TE3.R.5.3 L TE3.L.5.3
1,85	1,95	TE3.0185.00 G R/L	R APGE L AMV5 X800	X400	5,6	5,0	R TE3.R.5.3 L TE3.L.5.3
2,15	2,25	TE3.0215.00 G R/L	R AB92 L AKUE X800	X400	5,6	5,0	R TE3.R.5.3 L TE3.L.5.3



Der Webcode stellt eine eindeutige und schnelle Verbindung in die digitale Welt dar. Verwenden Sie den Webcode u.a. im Internet um tagesaktuelle Informationen zu erhalten. Gerne können Sie diesen Webcode auch zur Bestellung verwenden. Hängen Sie dazu im Bestellfall - wie bei Schneidwerkzeugen gewohnt - noch den gewünschten Schneidstoff an. Der Webcode besteht im Standardbereich aus einem vierstelligen alphanumerischen Code.

The Webcode is a unique and fast connection between our part numbers and the digital world. Use it on our website and get up-to-date information fast, easy and reliable. You can also use this Webcode for your ordering process. Just add the grade code - if ordering a cutting insert - and the short ordering code is complete. The Webcode is a four digit alpha-numeric code which is available for every standard item.

1	2	3	2
TE3.0050.00 GR	X800	=	AH0J X800
TE3.0050.00 GL	X800	=	AF84 X800
A04.0016		=	AF2K

www.simtek.com/webcode/

- 1 Artikel//Item
- 2 Schneidstoff // Grade
- 3 Webcode

In der PDF-Version dieses Katalogs sind alle Webcodes und Querverweise verlinkt. Per Klick gelangen Sie darüber zu den verknüpften Informationen.

Webcodes and cross-references are interactive links in the PDF version of this catalog. A click on these links leads to the connected information.

Zusätzliche Querverweise und Informationen, auf jeder Katalogseite Extra cross-references and information, shown on every catalog page

Schnittwerte (Start) // Cutting parameters (start)		
f (außen//ext.) 0,04 mm/U	f (innen//int.) 0,03 mm/U	Vc Seite/Page 429

Passende Klemmhalter auf Seite // Suitable toolholders on page
323, 324, 325, 326, 327, 328

SP

HM

R

Legende
Legend

354

Scan QR-Code Oder besuchen Sie // Or Visit
www.simtek.info/cp/308

Im rechten oberen Bereich erhalten Sie zusätzliche Querverweise angezeigt. Diese führen zu passenden Trägerwerkzeugen, vergleichbaren Werkzeugen, Schnittwerten und weiterführenden Hinweisen. Die entsprechenden Informationen finden Sie auf den angegebenen Seitenzahlen.

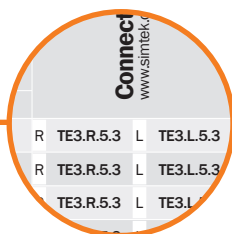
You can find additional information and cross-references in the upper right corner. These cross-references lead to Compatible Toolholders, Similar tools, Cutting parameters and additional notes. The corresponding information can be found on the shown page numbers.



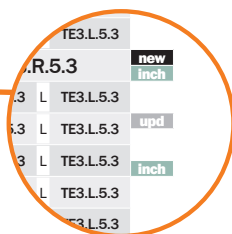
Der SIMTEK Hauptkatalog R21.DE Update 1 nutzt durchgängig QR-Codes. Sie können diese QR-Codes mit einer geeigneten, kostenlosen APP auf aktuellen Smartphones und Tablet-PCs scannen und erhalten darüber in sekundenschnelle tagesaktuelle Verfügbarkeiten, Preise und weitere Bestellhinweise für die entsprechende Katalogseite. Sie erhalten alternativ dieselbe Auskunft, wenn Sie die angegebene Internetadresse aufrufen.

The SIMTEK main catalog R21.DE Update 1 provides QR-codes on every catalog page. You can easily scan this QR-code with an APP on your Smartphone or Tablet-PC. Most of these apps are available free of charge. Scanning this code leads you to additional information about availabilities, prices and further ordering information for the corresponding catalog page. You can also access this information by visiting the mentioned web address.

„QR Code“ ist ein eingetragenes Markenzeichen der DENSO WAVE INCORPORATED // „QR Code“ is a registered trademark of DENSO WAVE INCORPORATED



Details zum Connectcode finden Sie auf der nächsten Seite.
Please find details about the Connectcode on the following page.



new Dieses Werkzeug wurde dem Katalog neu hinzugefügt.
This tool has been added to the catalog.

upd An diesem Werkzeug gab es im Vergleich zum vorherigen Katalog maßliche Änderungen. // There have been dimensional changes to this tool compared to the previous catalog.

inch Dieses Werkzeug ist speziell nach Inch-Maßen ausgelegt.
This tool is specially designed according to inch dimensions.

TE3.0110.00 G R/L R AP21 L AJJB

Bitte beachten Sie, dass rechte und linke Artikel jeweils einen eigenständigen Webcode und Connectcode tragen. Der jeweilige Code ist mit einem Zusatz R (für rechts) und L (für links) kenntlich gemacht.

Please note, that right hand and left hand items are named with an individual Webcode and/or Connectcode. The code for the right and left hand items is indicated with a leading R (right hand) or L (left hand).

Der Connectcode The Connectcode

Nutzen Sie den „Connectcode“ um auf einfachste Weise zu ermitteln, welche Kombination aus Schneidwerkzeug und Werkzeugträger von uns empfohlen ist. Dieser „Connectcode“ wird sowohl bei Schneidwerkzeugen als auch bei Werkzeugträgern ausgewiesen - vorausgesetzt das System benötigt ein Trägerwerkzeug für den Einsatz.

Stimmen beide Werte überein, können Sie diese Kombination bedenkenlos einsetzen. Andere Kombinationen sind ebenfalls möglich, jedoch können diese zu einem eingeschränkten Funktionsumfang führen.

Please use the „Connectcode“ in order to verify which combination between cutting insert and toolholder is recommended. This „Connectcode“ is shown on catalog pages of cutting inserts as well as on catalog pages of toolholders - if the tool system does not require the use of a toolholder, no „Connectcode“ is given.

Identical values indicate that the combination of insert and toolholder is recommended. Different combinations can be possible too at the possible expense of other tool characteristics.

Connectcode <small>www.simtek.com/code</small>	Schneidwerkzeug // Cutting Tool									
	D07	D08	D09	D10	D11	D14	D14.A.R	D16	D18	
D07	●	-	-	-	-	-	-	-	-	
D08	-	●	-	-	-	-	-	-	-	
D09	-	-	●	-	-	-	-	-	-	
D10	-	-	-	●	-	-	-	-	-	
D11	-	-	-	-	●	-	-	-	-	
D14	-	-	-	-	-	●	-	-	-	
D14.A.R	-	-	-	-	-	-	●	-	-	
D16	-	-	-	-	-	-	-	●	-	
D18	-	-	-	-	-	-	-	-	●	

- Empfohlene Kombination // Recommended combination
- Nicht empfohlen // Not recommended

Die obige Tabelle zeigt beispielhaft die „Connectcodes“ der Produktgruppe simturn DX an. Ein ausgefüllter orangener Punkt in der Schnittstelle steht für eine vollständige Kompatibilität.

This table contains all the „Connectcodes“ from the simturn DX range. A full orange circle on the intersection of cutting tool and toolholder indicates that the connection of both items is recommended.

Werkzeuge nach Ihrem Bedarf Tools according to your need

Werkzeuge nach Ihrem Bedarf: Ganz einfach mit simtek-individual.

Einige Katalogseiten weisen einen simtek-individual-Schlüssel auf. Nutzen Sie diesen in der unten angegebenen Weise um eine Artikelnummer für ein Werkzeug nach Ihrem Bedarf zu erstellen.

Tools according to your need: Very easy with simtek-individual.

Some catalog pages show a simtek-individual-key. Use this code as stated below in order to create a part number that represents a tool according to your need.

simtek individual A05. w, 1/100 mm, 3 Stellen/Digits . L2, 1/1 mm, 2 Stellen/Digits .52. R, 1/100 mm, 3 Stellen/Digits Toleranz // Tolerance R/L
Beispielartikelnummer // Example Part number: A05.137.15.52.015 XG R oder//or A05.137.15.52.015 XG L

Beispielcode // Example

- Der angegebenen Code ist eine Vorlage. Ersetzen Sie die blau hinterlegten Platzhalter durch die von Ihnen gewünschten Maße.
The given code on the catalog page is a template. Replace the blue fields with the measures you require.
- Bestimmen Sie die Schneidenbreitentoleranz durch das Anhängen des Toleranzklassencodes. Die verfügbaren Toleranzklassen sind:
Define the required cutting width tolerance by adding the right tolerance class code. These tolerance classes are available:

Toleranzklassen-Code Tolerance class code	XG	XN	XE	XD
Schneidenbreitentoleranz Tolerance of the cutting edge width	±0,01 mm	±0,02 mm	-0,03 mm	+0,03 mm

- Nutzen Sie den erstellten Code um damit Preis und Lieferzeit bei unserer Fachabteilung für Individualwerkzeuge anzufragen:
Contact the customized tool department for current price and delivery time using the created code:

fon +49 7473 9517 - 160 // fax +49 7473 9517 - 78 // mail offer@simtek.com

Beispiel auf Basis des obigen simtek-individual-Schlüssels
Example based on the above simtek-individual-key

A05. 137 . 15 .52. 015 XG R

Gewünschte Schneidenbreite (w) Required cutting edge width (w)	1,37 mm	137
Gewünschte Auskragung (L2) Required usable length (L2)	15,0 mm	15
Gewünschter Eckenradius (R) Required corner radius (R)	0,15 mm	015
Gewünschte Schneidenbreitentoleranz Required tolerance of the cutting edge width	±0,01 mm	XG

Das Werkzeugsystem im Überblick
The Tool System Overview

Großartige **Leistung** in
Bohrungen **ab Ø 0,3 mm.**

Great **performance**
in bores **as of Ø 0,3 mm.**

Auswahl der Anwendungen // Choice of Applications

Ausdrehen · Kopieren · Profildrehen · Rückwärtsdrehen · Fasen · Nutenstechen · Gewinden · Axialstechen
Boring · Copying · Profiling · Back Boring · Chamfering · Grooving · Threading · Face Grooving

Übersicht aller Anwendungen ab Seite 23
Overview of all applications as of page 23

Hauptanwendungen // Main Applications

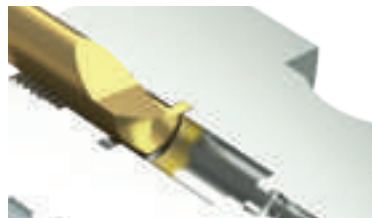
Ausdrehen Boring



Ausdrehen ab Bohrungsdurchmesser 0,3 mm. Erhältlich mit verschiedenen, optimierten Schneidengeometrien, sowie mit CBN-Bestückung für die Hartbearbeitung.

Boring applications as of bore diameter 0,3 mm. Available with different geometries as well as for hard part turning with CBN grades.

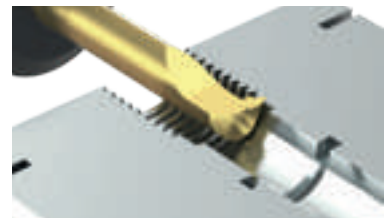
Nutenstechen Grooving



Vielzahl an Standardwerkzeugen für das Nutenstechen in unterschiedlichen Schneidbreiten und mit unterschiedlicher nutzbarer Länge. Auch als Vollradiusvarianten mit verschiedenen Radien erhältlich.

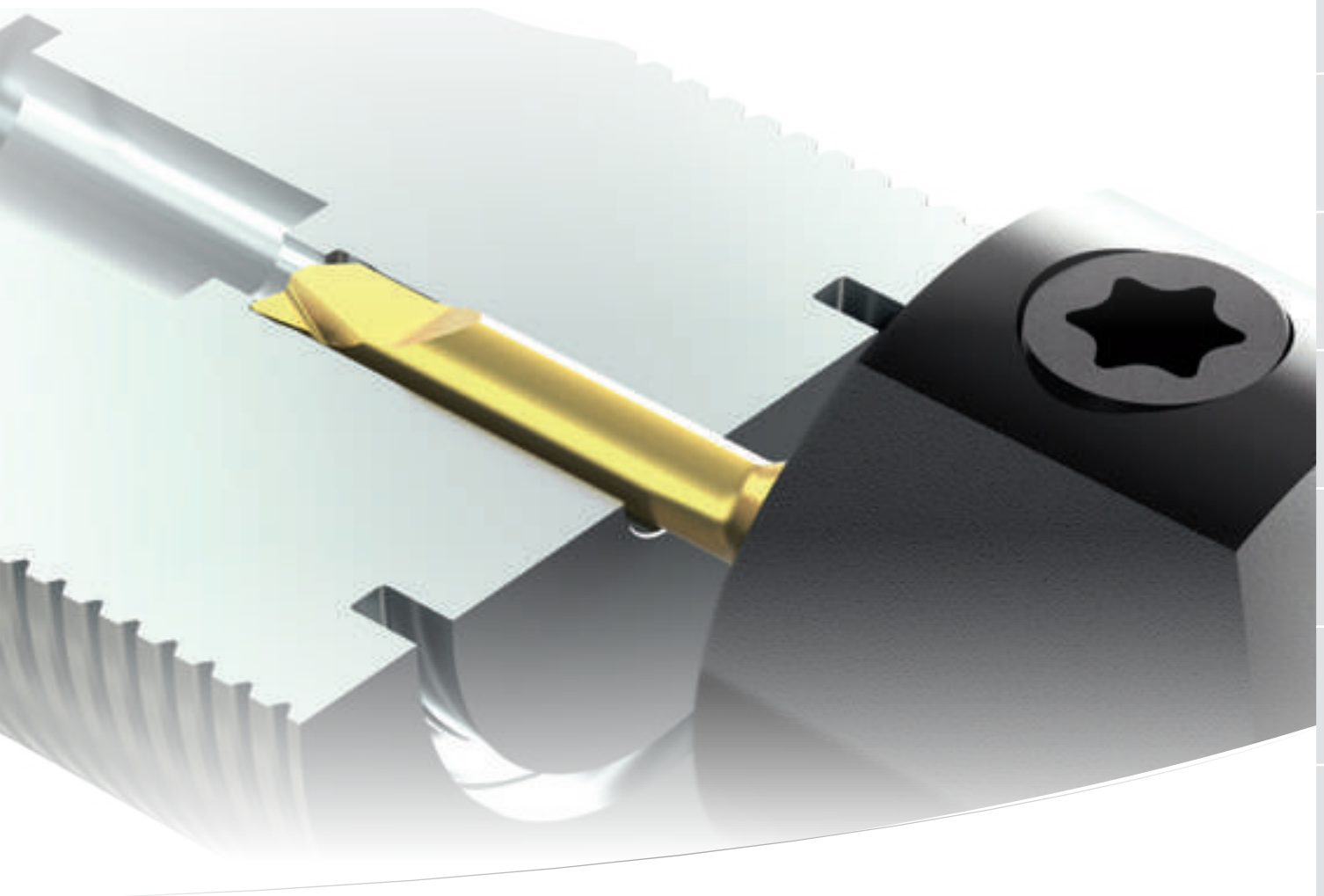
Grooving in bores as of minimum bore diameter 2,0 mm. With different cutting edge widths, usable lengths as well as with full radius.

Gewinden Threading



Große Auswahl an Werkzeugen für die Herstellung aller gängigen Gewindearten in verschiedenen Größen, Steigungen und Gängen.

Inserts for the machining of internal threads for all major types of threads. Available in different sizes and for different pitches or threads.



Axialstechen Face Grooving



Werkzeuge zum Axialstechen in Bohrungen oder an Zapfen. Schneideinsätze auch mit integriertem Kühlmittelkanal sowie mit Vollradius verfügbar.

Inserts for face grooving in bores or on pivots. Also available with coolant supply through the insert as well as with full radius.

ME-Spannprinzip ME-clamping system



Klemmhalter mit innovativem „ME“-Spannprinzip zum kraftschlüssigen Umspannen des Schneideinsatzes. Vier verschiedene Kühlmittelezufuhrarten (R, L, R+L oder Kühlung durch den Schneideinsatz) je nach Bedarf einstellbar.

Toolholders with innovative „ME“-clamping system for force-fitted clamping. Four different types of through coolant supply (R, L, R+L or supply through the insert) individually adjustable as required.

simtek individual

simtek  individual

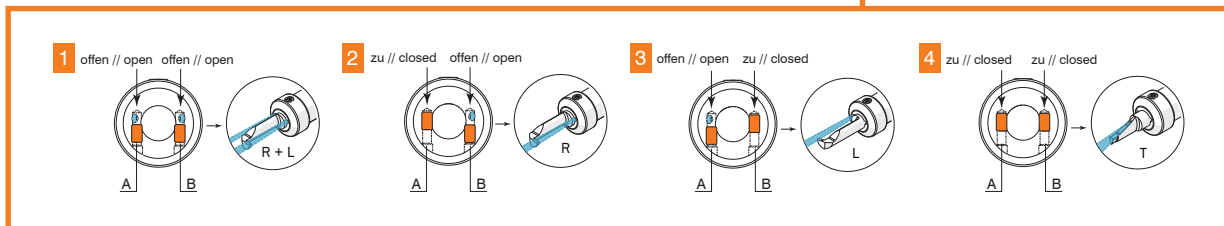
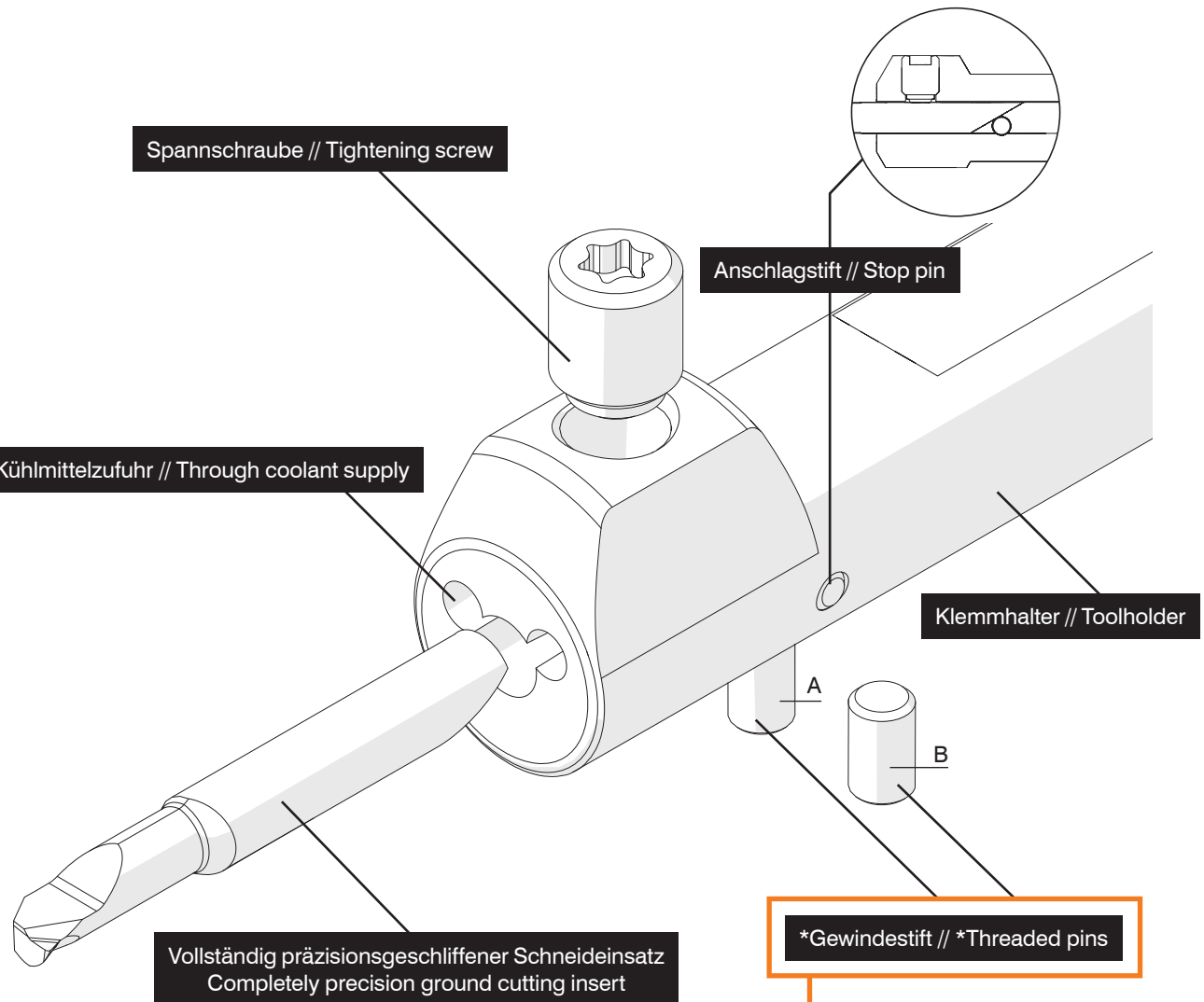
Neben unseren Standardwerkzeugen bieten wir Ihnen auf vielen Seiten die Möglichkeit eine Artikelnummer für ein Werkzeug nach Ihrem Bedarf zu erstellen. Nutzen Sie hierfür einfach den simtek-individual-Schlüssel! (siehe auch Seite 15)

Some catalog pages show a simtek-individual-key, which can be used to create a part number which represents a tool according to your needs. (see page 15 for more information)

Das System im Detail The System Details

Bitte beachten Sie die allgemeinen Gebrauchshinweise auf Seite
 Please read the general instructions for use on page

433



*Zum individuellen Einstellen der Kühlmittelzufuhr bei folgenden Haltern
 *For adjusting the coolant supply individually on the following toolholders

A04...T ab // as of ØDg6 12,0 mm
 A05...T ab // as of ØDg6 12,0 mm
 A06...T, A07...T, A08...T, A10...T

Sehr präzises und sehr stabiles Werkzeugsystem bestehend aus Hartmetall-Schneideinsatz, Stahl- und Hartmetallträgerwerkzeugen. Für die optimale Bearbeitung von Bohrungen zwischen \varnothing 0,3 mm bis ca. 20,0 mm.

Very precise and very strong tool system of solid carbide cutting insert, steel and carbide toolholders. For best performance in bores between \varnothing 0,3 mm up to 20,0 mm.

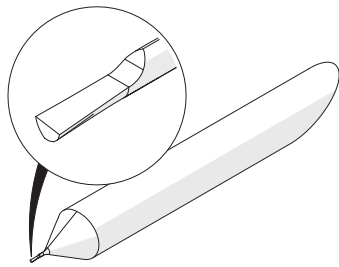
Hohe Wiederholgenauigkeit von Schneide zu Schneide und Auskraglängen bis zu 9xD!

High repeat accuracy from insert to insert and usable lengths up to 9xD!

Mit rund 3.000 Standardwerkzeugen für nahezu jede Anwendung ein passendes Werkzeug verfügbar.

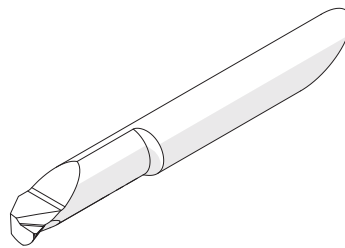
More than 3.000 standard items provide the right answer for almost every internal turning application.

A04



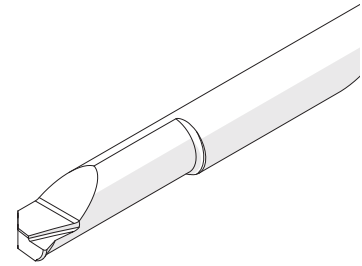
ØD	ØDmin	L2
mm	mm	mm
4,0	0,3 - 4,2	1,2 - 30,5

A05



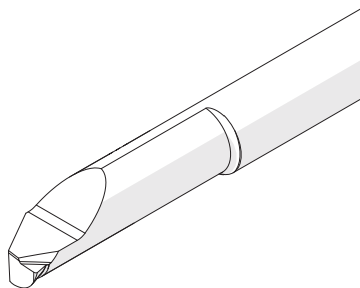
ØD	ØDmin	L2
mm	mm	mm
5,0	4,9 - 5,2	10,2 - 40,6

A06



ØD	ØDmin	L2
mm	mm	mm
6,0	5,9 - 6,2	15,2 - 40,6

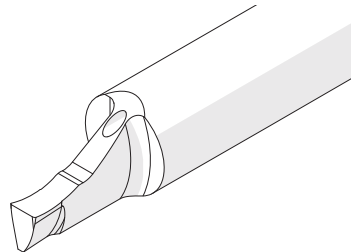
A07



ØD	ØDmin	L2
mm	mm	mm
7,0	7,2	25,4 - 50,8

A08

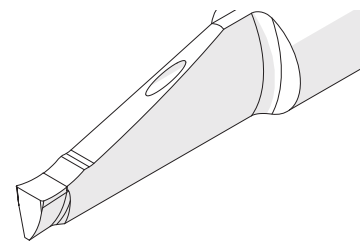
Axialbearbeitung // Face grooving



ØD	ØDmin	tmax
mm	mm	mm
8,0	16,0	10,0 - 15,0

A10

Axialbearbeitung // Face grooving



ØD	ØDmin	tmax
mm	mm	mm
10,0	20,0	20,0 - 30,0

- ØD Aufnahme Durchmesser // Connection diameter
- ØDmin Geeignet ab Bohrungsdurchmesser // Suitable as of bore diameter
- L2 Nutzlänge // Usable length
- tmax Maximale Schnitttiefe // Maximum cutting depth

Optimale Präzision und Stabilität durch das ME-Spannprinzip
Higher precision and stability with the ME-clamping system

Ab Seite
As of page

40

1 Halter – 4 Kühlmittelzufuhrarten
1 toolholder – 4 through coolant supplies



*Deutsches Patent Nr. 10 2014 111 898 / German Patent No. 10 2014 111 898

** Eingetragenes Gebrauchsmuster Nr. DE 20 2015 101 834.7 // Registered utility model no. DE 20 2015 101 834.7

Durch das innovative ME-Spannprinzip*, bei dem der Schneideinsatz von allen Seiten kraftschlüssig umspannt wird, bieten unsere simturn AX Rundschäfte optimale Präzision und Stabilität.

Diese Trägerwerkzeuge sind sowohl aus Stahl als auch aus Hartmetall erhältlich, wobei die Hartmetallausführungen besonders zur Erhöhung der möglichen Auskrägung geeignet sind.

Dank verstellbarer Gewindestifte können hier mit einem Halter vier mögliche Kühlmittelzufuhrarten (R, L, R+L oder Kühlung durch das Schneidwerkzeug) je nach Bedarf individuell realisiert werden**.

The innovative ME-clamping system* provides force-fitted clamping along with higher precision and stability.

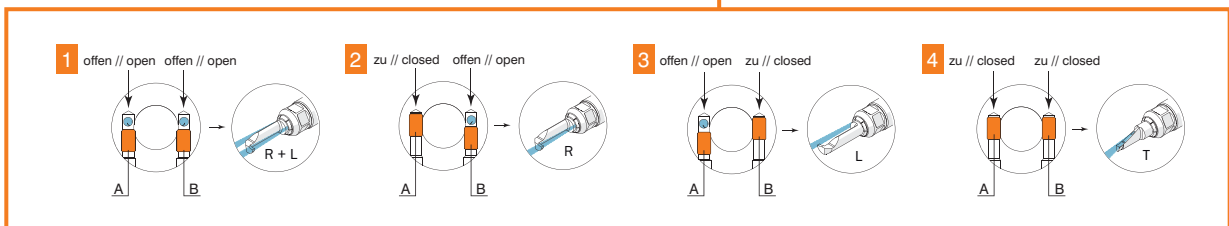
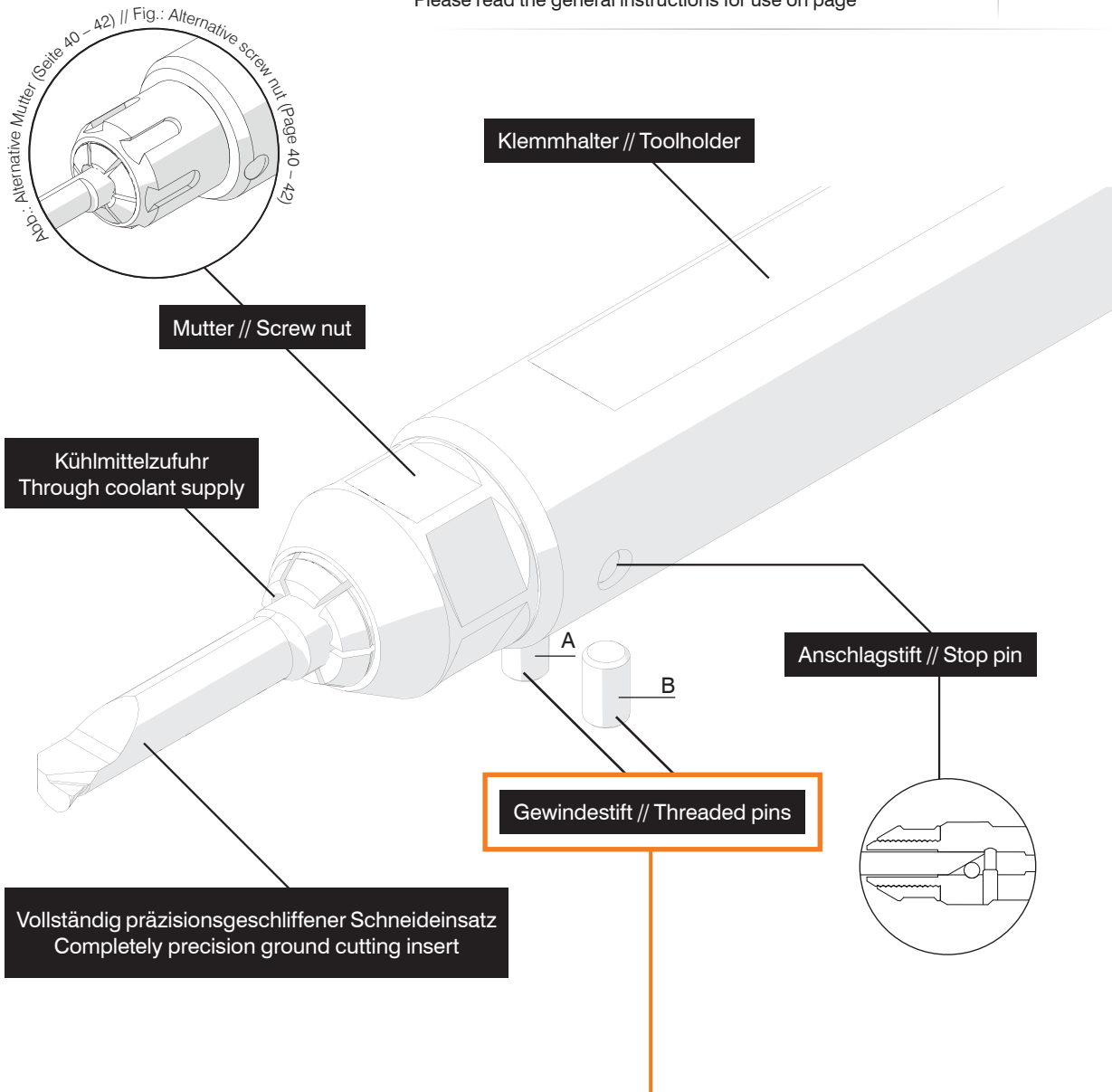
Those toolholders are available in steel as well as in carbide, whereas the carbide toolholders are especially suitable to extend the overall tool reach.

Thanks to adjustable threaded pins, four different types of coolant supply (R, L, R+L or supply through the insert) can individually be realized as required**.

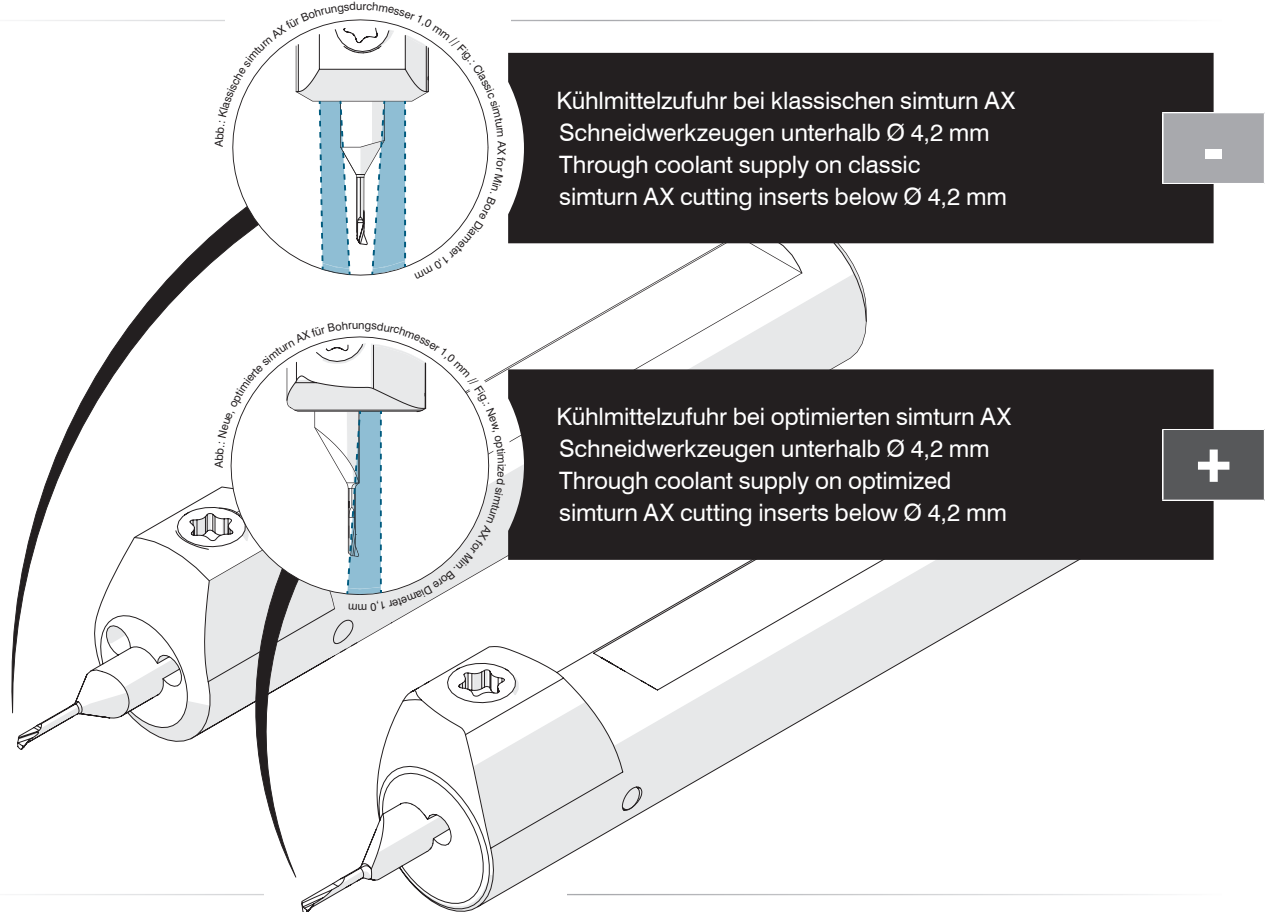
Das ME-System im Detail The ME-System Details




Bitte beachten Sie die allgemeinen Gebrauchshinweise auf Seite
 Please read the general instructions for use on page


433






Wählen Sie das Plus für eine optimierte Kühlmittelzufuhr!
Choose the Plus for improved Through Coolant Supply!







+ Die klassischen Schneidwerkzeuge  /  und die optimierten Schneidwerkzeuge  sind zueinander **vollständig kompatibel**: Beide Varianten nutzen zwar einen eigenen Haltertyp, können jedoch uneingeschränkt wechselseitig genutzt werden.



+ Das  Symbol signalisiert, dass das Schneidwerkzeug für eine ideale Kühlmittelzufuhr optimiert ist. Für beste Ergebnisse wählen Sie bitte ein passendes Trägerwerkzeug anhand des jeweils angegebenen Connectcodes.


+ Die klassischen Schneidwerkzeuge für Bohrungsdurchmesser unterhalb 2,0 mm sind mit einem  gekennzeichnet. Bei diesen Werkzeugen empfehlen wir, für eine verbesserte Kühlmittelzufuhr, generell auf die optimierte Variante  zurückzugreifen.

+ Die klassischen Schneidwerkzeuge für Bohrungsdurchmesser oberhalb 2,0 mm sind mit einem  gekennzeichnet. Bei diesen Werkzeugen ist in der klassischen Variante eine ausreichend gute Kühlung gegeben.

+ The classic cutting inserts  /  and the optimized cutting inserts  are **fully compatible** to each other, meaning that each type of insert has a dedicated type of holder, but can be switched with each other.

+ The  sign indicates that the cutting insert was designed and optimized for an improved through coolant supply. Please choose a matching toolholder using the given Connectcode for best performance.

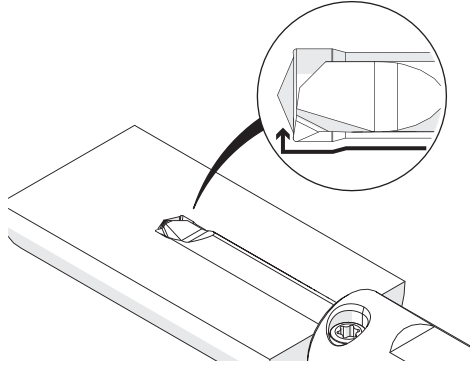
+ The classic cutting inserts for bore diameters below 2,0 mm are marked with a  sign. Our recommendation for these tools is, to rather use the optimized cutting inserts  for best through coolant supply.

+ The classic cutting inserts for bore diameters above 2,0 mm are marked with a  sign. These cutting inserts already provide a sufficient through coolant supply.

Standardanwendungen Standard Applications

Ab Seite
 As of Page

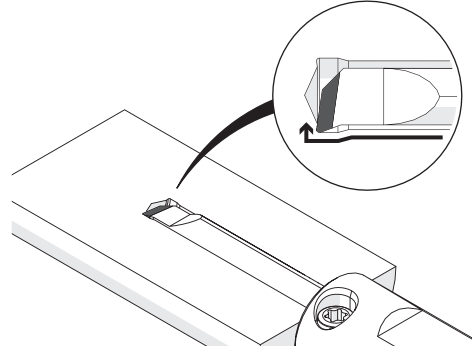
70



Ausdrehen
 Boring

Ab Seite
 As of Page

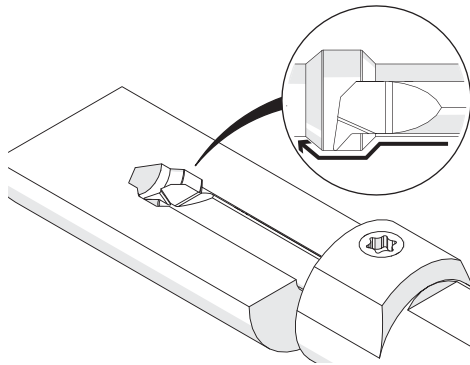
88



Ausdrehen, Hartbearbeitung
 Boring, Hard Part Turning

Seite
 Page

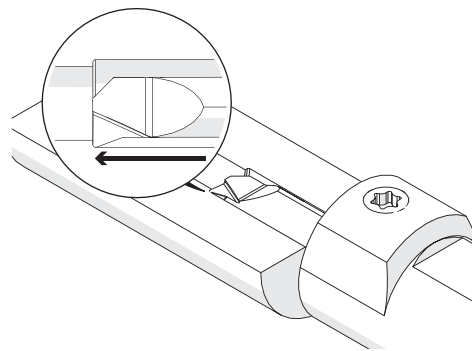
96



Kopieren und Profildrehen
 Copying and Profiling

Seite
 Page

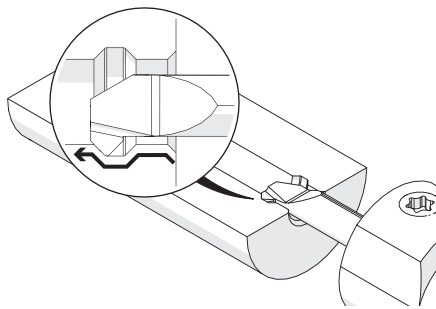
98



Bohrungen drehen
 Boring

Seite
 Page

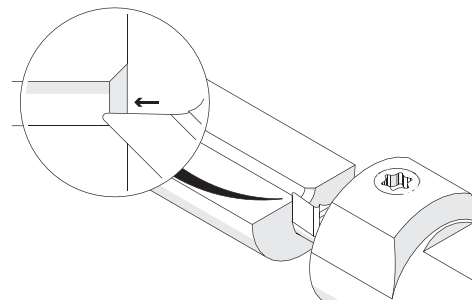
99



Ausdrehen und Fasen
 Boring and Chamfering

Seite
 Page

100

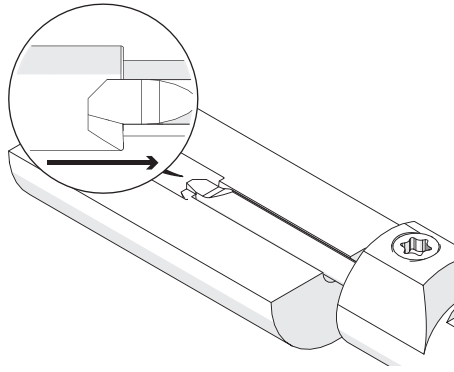


Fasen
 Chamfering

Standardanwendungen Standard Applications

Seite
 Page

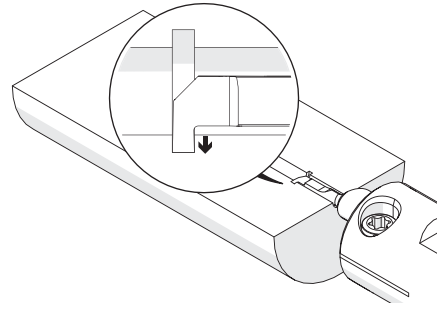
101



Rückwärtsdrehen
 Back Boring

Ab Seite
 As of Page

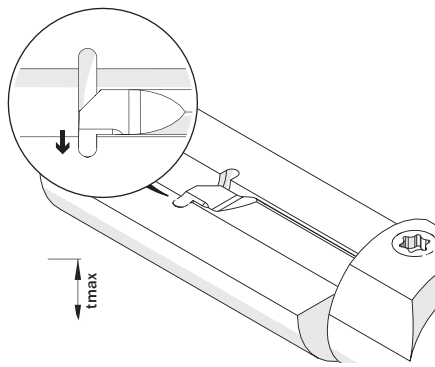
102



Nutenstechen
 Grooving

Seite
 Page

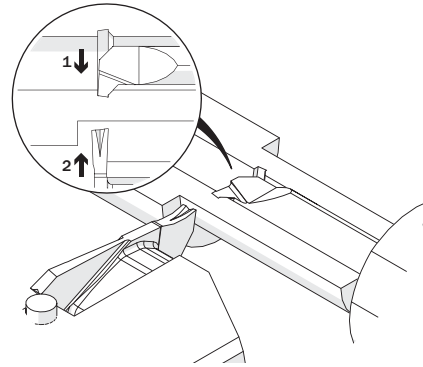
114



Stechen von Vollradiusnuten
 Full Radius Grooving

Seite
 Page

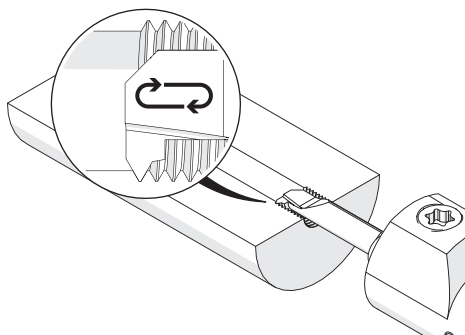
116



Vorstechen und Fasen
 Pre-Part Off and Chamfering

Ab Seite
 As of Page

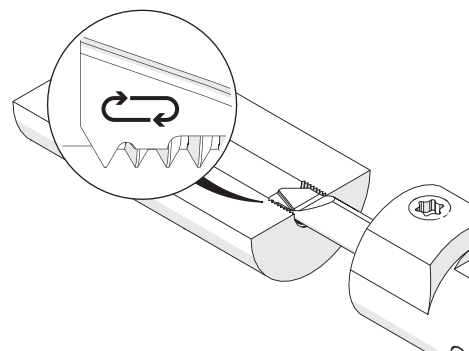
117



Gewinden: Metrisches ISO Teilprofil
 Threading: Metric ISO Partial Profile

Seite
 Page

119

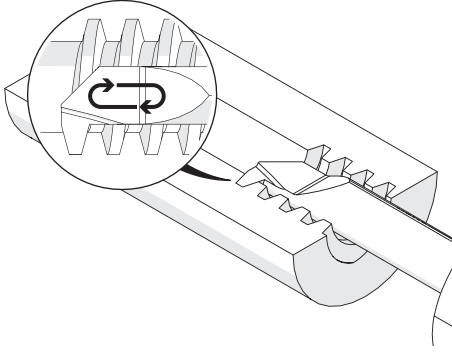


Gewinden: Metrisches ISO Vollprofil
 Threading: Metric ISO Full Profile

Standardanwendungen Standard Applications

Seite
 Page

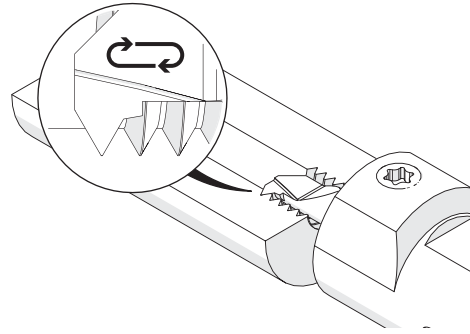
120



Gewinden: Trapezgewinde, Teilprofil
 Threading: Trapezoidal Thread, Partial Profile

Seite
 Page

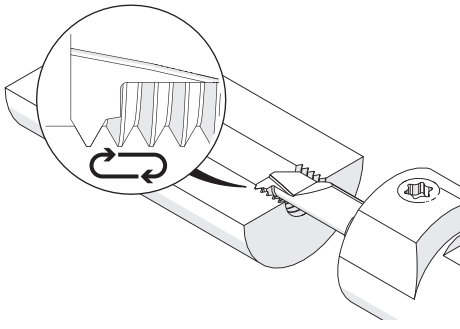
121



Gewinden: NPT, Teilprofil
 Threading: NPT, Partial Profile

Seite
 Page

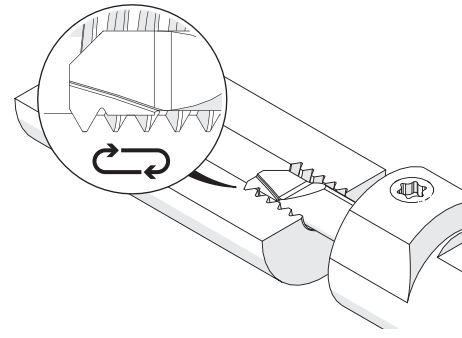
122



Gewinden: UN, Teilprofil
 Threading: UN, Partial Profile

Seite
 Page

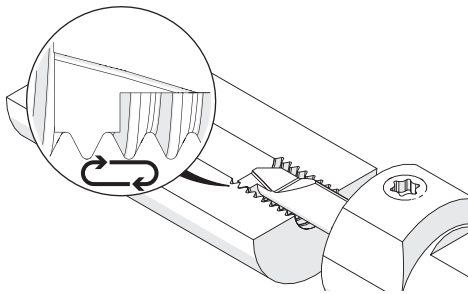
123



Gewinden: UNC / UNF, Vollprofil
 Threading: UNC / UNF, Full Profile

Seite
 Page

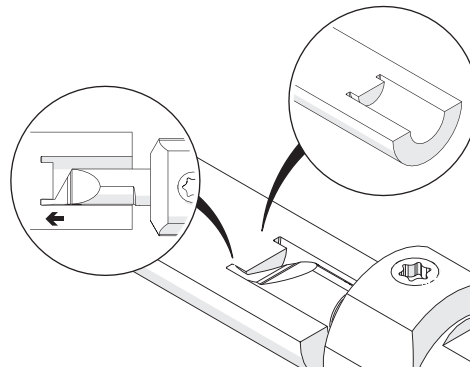
124



Gewinden: Whitworth, Vollprofil
 Threading: Whitworth, Full Profile

Ab Seite
 As of Page

127



Axialstechen
 Face Grooving

Klemmhalter, Innenbearbeitung, Rundschaft

Rundschaft mit innerer Kühlmittelzufuhr für die Größe A04.

Toolholder, Internal Applications, Round Shank

Round shank with through coolant for size A04.

Anzugsmoment (Schraube) // Tightening torque (screw)

7,0 Nm

Bitte Hinweise im Anhang beachten // Please read add. notes

MASTER (Seite/Page 137)

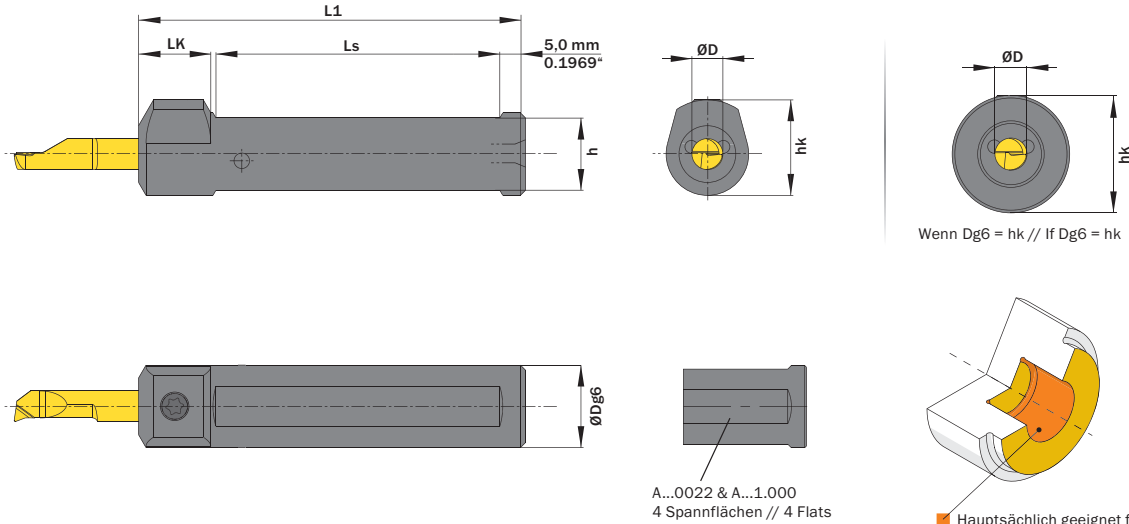


Legende
Legend **139**



Scan
QR-Code

Oder besuchen Sie // Or Visit
www.simtek.info/cp/746



ØD	ØDg6	Artikelnummer Part number	Webcode www.simtek.com/webcode	h	hk	L1	LK	Ls	Anzahl Spannflächen Number of flats	Schraube Screw	Schraubenschlüssel Screw driver	Connectcode www.simtek.com/code
4,0	10,0	A04.0010	AE46	8,0	14,5	65,0	14,0	45,0	2	AM6x7,5 T15F	T15F	A04.L A04.R
4,0	12,0	A04.0012	AE0X	10,0	15,5	70,0	14,0	50,0	2	AM6x7,5 T15F	T15F	A04.L A04.R
4,0	12,7	A04.0.500	AB2J	10,7	15,8	70,0	14,0	50,0	2	AM6x7,5 T15F	T15F	A04.L A04.R
4,0	15,875	A04.0.625	ACVJ	13,9	17,4	75,0	14,0	55,0	2	AM6x7,5 T15F	T15F	A04.L A04.R
4,0	16,0	A04.0016	AF2K	14,0	17,5	75,0	14,0	55,0	2	AM6x7,5 T15F	T15F	A04.L A04.R
4,0	19,05	A04.0.750	AJ4A	17,0	19,0	110,0	14,0	90,0	2	AM6x7,5 T15F	T15F	A04.L A04.R
4,0	20,0	A04.0020	AC6Y	18,0	20,0	90,0	14,0	70,0	2	AM6x7,5 T15F	T15F	A04.L A04.R
4,0	22,0	A04.0022	AD0V	20,0	22,0	110,0	-	90,0	4	AM6x7,5 T15F	T15F	A04.L A04.R
4,0	23,0	A04.0023	ANU4	21,0	23,0	110,0	-	90,0	2	AM6x7,5 T15F	T15F	A04.L A04.R
4,0	25,0	A04.0025	ACAS	23,0	25,0	110,0	-	90,0	2	AM6x7,5 T15F	T15F	A04.L A04.R
4,0	25,4	A04.1.000	AJWG	23,4	25,4	110,0	-	90,0	4	AM6x7,5 T15F	T15F	A04.L A04.R

Verwandte Werkzeuge finden Sie auch auf der folgenden Seite!
Related items can be found on the following page as well!

Fortgesetzte Tabelle
Continued Table

Bestellbeispiel // Order example: **A04.0016**

Klemmhalter, Innenbearbeitung, Rundschaft

Rundschaft mit innerer Kühlmittelzufuhr für die Größe A05.

Toolholder, Internal Applications, Round Shank

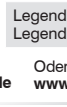
Round shank with through coolant for size A05.

Anzugsmoment (Schraube) // Tightening torque (screw)

7,0 Nm

Bitte Hinweise im Anhang beachten // Please read add. notes

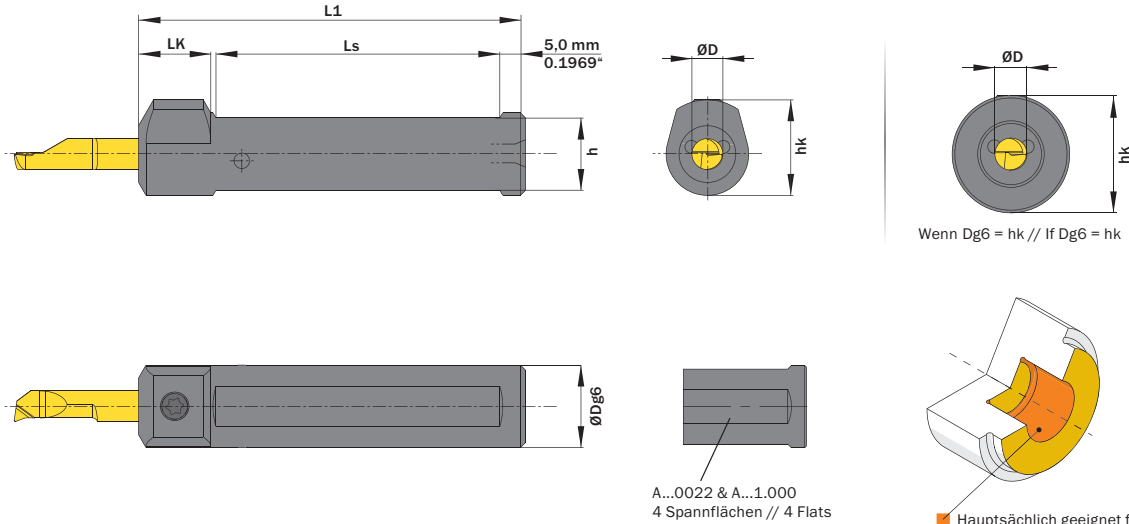
MASTER (Seite/Page 137)



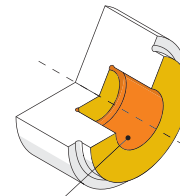
Legende
Legend **139**

Scan QR-Code

Oder besuchen Sie // Or Visit
www.simtek.info/cp/782



Wenn Dg6 = hk // If Dg6 = hk



- Hauptsächlich geeignet für diese Flächen
Mainly designed for these surfaces
- Je nach Schneidplatte ebenfalls möglich
Also possible depending on insert type

ØD	ØDg6	Artikelnummer Part number	Webcode www.simtek.com/webcode	h	hk	L1	LK	Ls	Anzahl Spannflächen Number of flats	Schraube Screw	Schraubenschlüssel Screw driver	Connectcode www.simtek.com/code
mm	mm			mm	mm	mm	mm	mm				

◀ Fortgesetzte Tabelle
Continued Table

Verwandte Werkzeuge finden Sie auch auf der vorhergehenden Seite!
Related Items can be found on the previous page as well!

5,0	10,0	A05.0010	ABMY	8,0	15,0	65,0	14,0	45,0	2	A M6x7,5 T15F	T15F	A05.L A05.R
5,0	12,0	A05.0012	AEA9	10,0	16,0	70,0	14,0	50,0	2	A M6x7,5 T15F	T15F	A05.L A05.R
5,0	12,7	A05.0.500	AHQV	10,7	16,35	70,0	14,0	50,0	2	A M6x7,5 T15F	T15F	A05.L A05.R inch
5,0	15,875	A05.0.625	AGG2	13,88	17,94	75,0	14,0	55,0	2	A M6x7,5 T15F	T15F	A05.L A05.R inch
5,0	16,0	A05.0016	AEFG	14,0	18,0	75,0	14,0	55,0	2	A M6x7,5 T15F	T15F	A05.L A05.R
5,0	19,05	A05.0.750	AAF8	17,05	19,05	110,0	14,0	90,0	2	A M6x7,5 T15F	T15F	A05.L A05.R inch
5,0	20,0	A05.0020	ABDK	18,0	20,0	90,0	14,0	70,0	2	A M6x7,5 T15F	T15F	A05.L A05.R
5,0	22,0	A05.0022	AG78	20,0	22,0	110,0	-	90,0	4	A M6x7,5 T15F	T15F	A05.L A05.R
5,0	23,0	A05.0023	AGZX	21,0	23,0	110,0	-	90,0	2	A M6x7,5 T15F	T15F	A05.L A05.R
5,0	25,0	A05.0025	AMVA	23,0	25,0	110,0	-	90,0	2	A M6x7,5 T15F	T15F	A05.L A05.R
5,0	25,4	A05.1.000	AMM2	23,4	25,4	110,0	-	90,0	4	A M6x7,5 T15F	T15F	A05.L A05.R inch

Verwandte Werkzeuge finden Sie auch auf der folgenden Seite!
Related Items can be found on the following page as well!

▶ Fortgesetzte Tabelle
Continued Table

Bestellbeispiel // Order example: **A05.0016**

Klemmhalter, Innenbearbeitung, Rundschaft

Rundschaft mit innerer Kühlmittelzufuhr für die Größe A06.

Toolholder, Internal Applications, Round Shank

Round shank with through coolant for size A06.

Anzugsmoment (Schraube) // Tightening torque (screw)

7,0 Nm

Bitte Hinweise im Anhang beachten // Please read add. notes

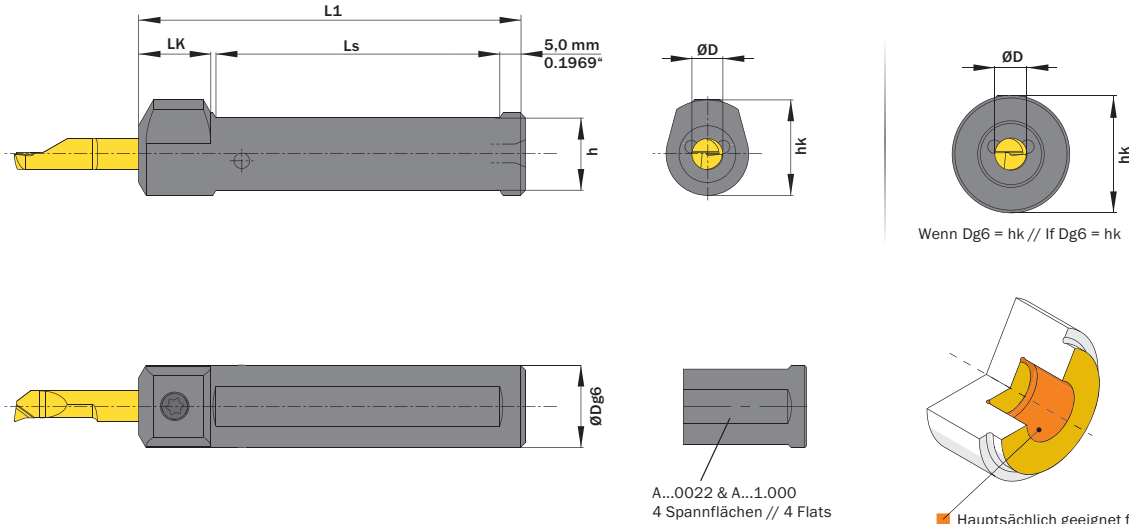
MASTER (Seite/Page 137)



Legende
Legend **139**

Scan
QR-Code

Oder besuchen Sie // Or Visit
www.simtek.info/cp/783



ØD	ØDg6	Artikelnummer Part number	Webcode www.simtek.com/webcode	h	hk	L1	LK	Ls	Anzahl Spannflächen Number of flats	Schraube Screw	Schraubenschlüssel Screw driver	Connectcode www.simtek.com/code
mm	mm			mm	mm	mm	mm	mm				

◀ Fortgesetzte Tabelle
Continued Table

Verwandte Werkzeuge finden Sie auch auf der vorhergehenden Seite!
Related items can be found on the previous page as well!

6,0	12,0	A06.0012	AE6Z	10,0	16,5	70,0	14,0	50,0	2	A M6x7,5 T15F	T15F	A06.L A06.R
6,0	12,7	A06.0.500	ADG8	10,7	16,85	70,0	14,0	50,0	2	A M6x7,5 T15F	T15F	A06.L A06.R <small>inch</small>
6,0	15,875	A06.0.625	AF4V	13,88	18,44	75,0	14,0	55,0	2	A M6x7,5 T15F	T15F	A06.L A06.R <small>inch</small>
6,0	16,0	A06.0016	ANUJ	14,0	18,5	75,0	14,0	55,0	2	A M6x7,5 T15F	T15F	A06.L A06.R
6,0	19,05	A06.0.750	AE0N	17,05	21,0	110,0	14,0	90,0	2	A M6x7,5 T15F	T15F	A06.L A06.R <small>inch</small>
6,0	20,0	A06.0020	AEV6	18,0	22,0	90,0	14,0	70,0	2	A M6x7,5 T15F	T15F	A06.L A06.R
6,0	22,0	A06.0022	AAW6	20,0	22,0	110,0	-	90,0	4	A M6x7,5 T15F	T15F	A06.L A06.R
6,0	23,0	A06.0023	AAMQ	21,0	23,0	110,0	-	90,0	2	A M6x7,5 T15F	T15F	A06.L A06.R
6,0	25,0	A06.0025	AGFG	23,0	25,0	110,0	-	90,0	2	A M6x7,5 T15F	T15F	A06.L A06.R
6,0	25,4	A06.1.000	AFYZ	23,4	25,4	110,0	-	90,0	4	A M6x7,5 T15F	T15F	A06.L A06.R <small>inch</small>

Verwandte Werkzeuge finden Sie auch auf der folgenden Seite!
Related items can be found on the following page as well!

Fortgesetzte Tabelle
Continued Table ▶

Bestellbeispiel // Order example: **A06.0016**

Klemmhalter, Innenbearbeitung, Rundschaft

Rundschaft mit innerer Kühlmittelzufuhr für die Größe A07.

Toolholder, Internal Applications, Round Shank

Round shank with through coolant for size A07.

Anzugsmoment (Schraube) // Tightening torque (screw)

7,0 Nm

Bitte Hinweise im Anhang beachten // Please read add. notes

MASTER (Seite/Page 137)



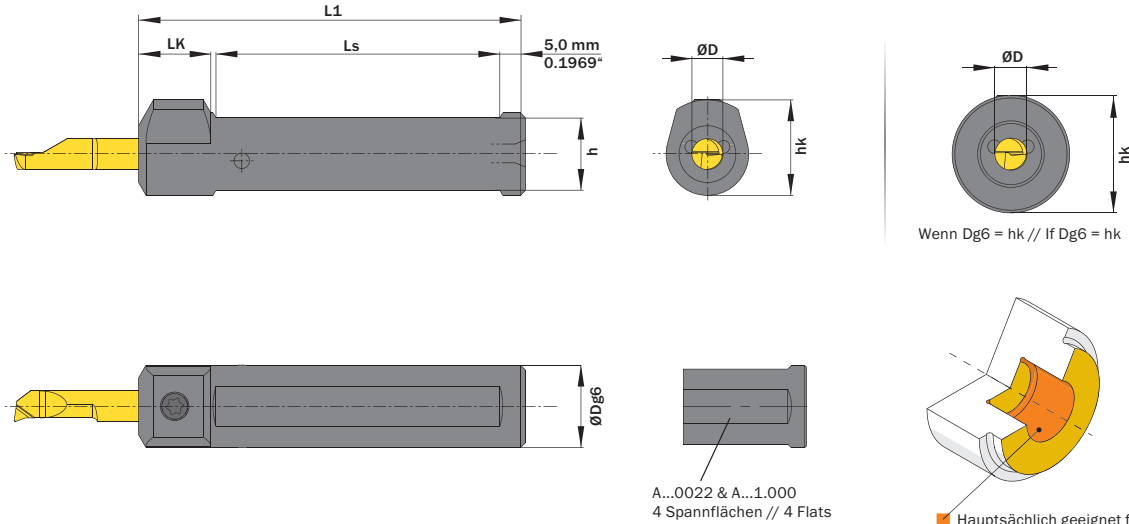
Legende
Legend

139



Scan
QR-Code

Oder besuchen Sie // Or Visit
www.simtek.info/cp/784



A...0022 & A...1.000
4 Spannflächen // 4 Flats

- Hauptsächlich geeignet für diese Flächen
Mainly designed for these surfaces
- Je nach Schneidplatte ebenfalls möglich
Also possible depending on insert type

ØD	ØDg6	Artikelnummer Part number	Webcode www.simtek.com/webcode	h	hk	L1	LK	Ls	Anzahl Spannflächen Number of flats	Schraube Screw	Schraubenschlüssel Screw driver	Connectcode www.simtek.com/code
mm	mm			mm	mm	mm	mm	mm				

◀ Fortgesetzte Tabelle
Continued Table

Verwandte Werkzeuge finden Sie auch auf der vorhergehenden Seite!
Related items can be found on the previous page as well!

7,0	15,875	A07.0.625	AJD9	13,88	18,94	75,0	14,0	55,0	2	A M6x7,5 T15F	T15F	A07L A07.R	inch
7,0	16,0	A07.0016	ANSH	14,0	19,0	75,0	14,0	55,0	2	A M6x7,5 T15F	T15F	A07L A07.R	
7,0	19,05	A07.0.750	AGC1	17,05	21,0	110,0	14,0	90,0	2	A M6x7,5 T15F	T15F	A07L A07.R	inch
7,0	20,0	A07.0020	AJ4T	18,0	22,0	90,0	14,0	70,0	2	A M6x7,5 T15F	T15F	A07L A07.R	
7,0	22,0	A07.0022	AE9S	20,0	22,0	110,0	-	90,0	4	A M6x7,5 T15F	T15F	A07L A07.R	
7,0	23,0	A07.0023	AA1N	21,0	23,0	110,0	-	90,0	2	A M6x7,5 T15F	T15F	A07L A07.R	
7,0	25,0	A07.0025	AEK6	23,0	25,0	110,0	-	90,0	2	A M6x7,5 T15F	T15F	A07L A07.R	
7,0	25,4	A07.1.000	AD79	23,4	25,4	110,0	-	90,0	4	A M6x7,5 T15F	T15F	A07L A07.R	inch

Verwandte Werkzeuge finden Sie auch auf der folgenden Seite!
Related items can be found on the following page as well!

▶ Fortgesetzte Tabelle
Continued Table

Bestellbeispiel // Order example: **A07.0016**

Klemmhalter, Innenbearbeitung, Rundschaft

Rundschaft mit innerer Kühlmittelzufuhr für die Größen A08 und A10.

Toolholder, Internal Applications, Round Shank

Round shank with through coolant for size A08 and A10.

Anzugsmoment (Schraube) // Tightening torque (screw)

7,0 Nm

Bitte Hinweise im Anhang beachten // Please read add. notes

MASTER (Seite/Page 137)



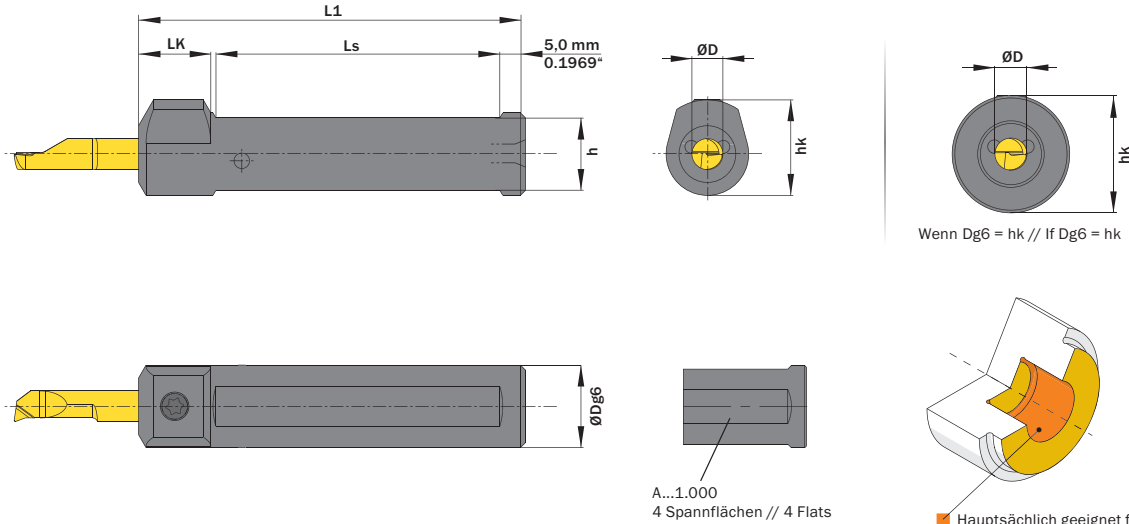
Legende
Legend

139



Scan
QR-Code

Oder besuchen Sie // Or Visit
www.simtek.info/cp/785



Wenn Dg6 = hk // If Dg6 = hk

A...1.000
4 Spannflächen // 4 Flats

- Hauptsächlich geeignet für diese Flächen
Mainly designed for these surfaces
- Je nach Schneidplatte ebenfalls möglich
Also possible depending on insert type

ØD	ØDg6	Artikelnummer Part number	Webcode www.simtek.com/webcode	h	hk	L1	LK	Ls	Anzahl Spannflächen Number of flats	Schraube Screw	Schraubenschlüssel Screw driver	Connectcode www.simtek.com/code
mm	mm			mm	mm	mm	mm	mm				

Fortgesetzte Tabelle
Continued Table

Verwandte Werkzeuge finden Sie auch auf der vorhergehenden Seite!
Related items can be found on the previous page as well!

▼ ØD = 8,0 mm													
8,0	15,875	A08.0.625	AHYF	13,88	19,44	75,0	14,0	55,0	2	A M6x7,5 T15F	T15F	A08	Inch
8,0	16,0	A08.0016	AAAV	14,0	19,5	75,0	14,0	55,0	2	A M6x7,5 T15F	T15F	A08	Inch
8,0	19,05	A08.0.750	AAKN	17,05	24,0	110,0	14,0	90,0	2	A M6x7,5 T15F	T15F	A08	Inch
8,0	20,0	A08.0020	AD6N	18,0	25,0	90,0	14,0	70,0	2	A M6x7,5 T15F	T15F	A08	Inch
8,0	25,0	A08.0025	AMAS	23,0	25,0	110,0	-	90,0	2	A M6x7,5 T15F	T15F	A08	Inch
8,0	25,4	A08.1.000	AAQJ	23,4	25,4	110,0	-	90,0	4	A M6x7,5 T15F	T15F	A08	Inch
▼ ØD = 10,0 mm													
10,0	19,05	A10.0.750	AEJ2	17,05	24,0	110,0	14,0	90,0	2	A M6x7,5 T15F	T15F	A10L A10.R	Inch
10,0	20,0	A10.0020	AGQZ	18,0	25,0	90,0	14,0	70,0	2	A M6x7,5 T15F	T15F	A10L A10.R	Inch
10,0	25,0	A10.0025	ABB8	23,0	25,0	110,0	-	90,0	2	A M6x7,5 T15F	T15F	A10L A10.R	Inch
10,0	25,4	A10.1.000	AHAY	23,4	25,4	110,0	-	90,0	4	A M6x7,5 T15F	T15F	A10L A10.R	Inch

Verwandte Werkzeuge finden Sie auch auf der folgenden Seite!
Related items can be found on the following page as well!

Fortgesetzte Tabelle
Continued Table

Bestellbeispiel // Order example: **A10.0020**

Klemmhalter, Innenbearbeitung, Rundschaft

Rundschaft mit innerer Kühlmittelzufuhr.

Toolholder, Internal Applications, Round Shank

Round shank with through coolant.

Anzugsmoment (Schraube) // Tightening torque (screw)

7,0 Nm

Bitte Hinweise im Anhang beachten // Please read add. notes

MASTER (Seite/Page 137)



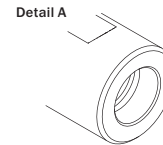
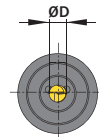
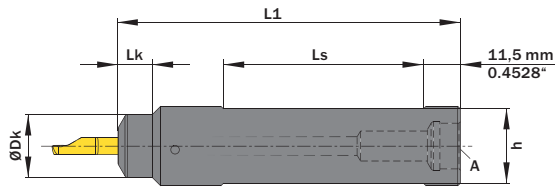
Legende
Legend

139

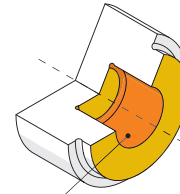


Scan
QR-Code

Oder besuchen Sie // Or Visit
www.simtek.info/cp/747



Anschlussgewinde M12 x 1,5
connection thread M12 x 1,5



- Hauptsächlich geeignet für diese Flächen
Mainly designed for these surfaces
- Je nach Schneidplatte ebenfalls möglich
Also possible depending on insert type

Abbildung zeigt / Drawing shows: A06.0028

ØD	ØDg6	Artikelnummer Part number	Webcode www.simtek.com/webcode	ØDk	h	L1	LK	Ls	Schraube Screw	Schraubenschlüssel Screw driver	Connectcode www.simtek.com/code
mm	mm			mm	mm	mm	mm	mm			

Fortgesetzte Tabelle
Continued Table

Verwandte Werkzeuge finden Sie auch auf der vorhergehenden Seite!
Related items can be found on the previous page as well!

▼ ØD = 4,0 mm											
4,0	28,0	A04.0028	AESG	20,0	26,0	120,0	17,0	72,0	A M6x7,5 T15F	T15F	A04.L A04.R A04C.L A04C.R
▼ ØD = 5,0 mm											
5,0	28,0	A05.0028	AFTF	20,0	26,0	120,0	12,0	72,0	A M6x7,5 T15F	T15F	A05.L A05.R
▼ ØD = 6,0 mm											
6,0	28,0	A06.0028	AEK4	22,0	26,0	120,0	12,0	72,0	A M6x7,5 T15F	T15F	A06.L A06.R
▼ ØD = 7,0 mm											
7,0	28,0	A07.0028	ADXC	22,0	26,0	120,0	12,0	72,0	A M6x7,5 T15F	T15F	A07.L A07.R

Bestellbeispiel // Order example: **A07.0028**

Klemmhalter, Innenbearbeitung, Rundschaft

Rundschaft mit innerer Kühlmittelzufuhr für die Größe A04.

Toolholder, Internal Applications, Round Shank

Round shank with through coolant for size A04.

Anzugsmoment (Schraube) // Tightening torque (screw)

7,0 Nm

Bitte Hinweise im Anhang beachten // Please read add. notes

MASTER (Seite/Page 137)



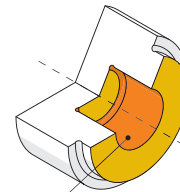
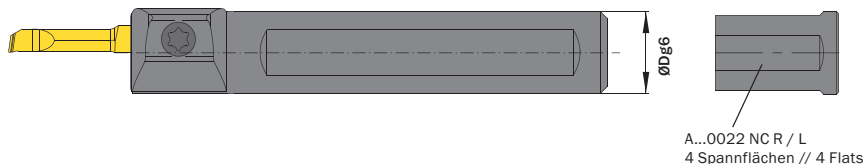
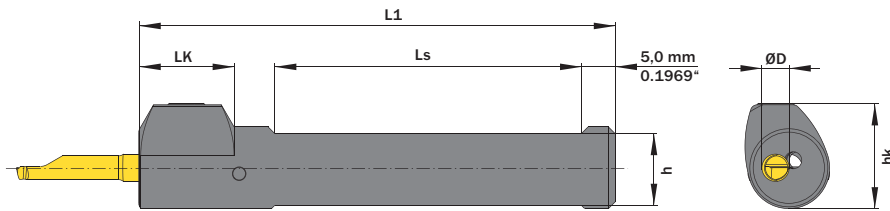
Legende
Legend

139



Scan
QR-Code

Oder besuchen Sie // Or Visit
www.simtek.info/cp/1004



- **Hauptsächlich geeignet für diese Flächen**
Mainly designed for these surfaces
- **Je nach Schneidplatte ebenfalls möglich**
Also possible depending on insert type

Abbildung zeigt / Drawing shows: A04.0012.NC R

ØD	ØDg6	Artikelnummer Part number	Webcode www.simtek.com/webcode		h	hk	L1	LK	Ls	Anzahl Spannflächen Number of flats	Schraube Screw	Schraubenschlüssel Screw driver	Connectcode www.simtek.com/code					
													R	L				
4,0	10,0	A04.0010.NC R/L	R	AWBQ	L	AWBP	8,5	13,75	65,0	14,0	40,0	2	AM6x7,5 T15F	T15F	R	A04C.R	L	A04C.L
4,0	12,0	A04.0012.NC R/L	R	AWBT	L	AWBS	10,5	15,25	70,0	14,0	45,0	2	AM6x7,5 T15F	T15F	R	A04C.R	L	A04C.L
4,0	12,7	A04.0.500.NC R/L	R	AWB3	L	AWB2	11,2	15,6	70,0	14,0	45,0	2	AM6x7,5 T15F	T15F	R	A04C.R	L	A04C.L
4,0	15,875	A04.0.625.NC R/L	R	AWB5	L	AWB4	14,38	17,14	75,0	14,0	55,0	2	AM6x7,5 T15F	T15F	R	A04C.R	L	A04C.L
4,0	16,0	A04.0016.NC R/L	R	AWBV	L	AWBU	14,5	17,2	75,0	14,0	55,0	2	AM6x7,5 T15F	T15F	R	A04C.R	L	A04C.L
4,0	19,05	A04.0.750.NC R/L	R	AWB1	L	AWB0	17,05	21,0	110,0	14,0	90,0	2	AM6x7,5 T15F	T15F	R	A04C.R	L	A04C.L
4,0	20,0	A04.0020.NC R/L	R	AWBX	L	AWBW	18,0	22,0	90,0	14,0	70,0	2	AM6x7,5 T15F	T15F	R	A04C.R	L	A04C.L
4,0	22,0	A04.0022.NC R/L	R	AWBZ	L	AWBY	20,0	22,0	110,0	-	90,0	4	AM6x7,5 T15F	T15F	R	A04C.R	L	A04C.L

Verwandte Werkzeuge finden Sie auch auf der folgenden Seite!
Related Items can be found on the following page as well!

Fortgesetzte Tabelle
Continued Table

Bestellbeispiel // Order example: **A04.0016.NC R** (R = Rechte Ausführung // Right hand version)

Klemmhalter, Innenbearbeitung, Rundschaft

Rundschaft mit innerer Kühlmittelzufuhr für die Größe A04.
Mit speziellen Kühlmittelauslässen für rechte und linke Schneidwerkzeuge.

Toolholder, Internal Applications, Round Shank

Round shank with through coolant for size A04.
With special through coolant design for right and left hand inserts.

Anzugsmoment (Schraube) // Tightening torque (screw)

7,0 Nm

Bitte Hinweise im Anhang beachten // Please read add. notes

MASTER (Seite/Page 137)



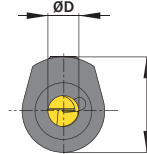
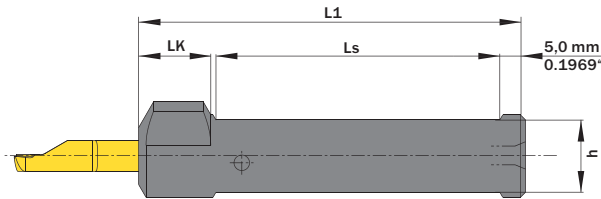
Legende
Legend

139

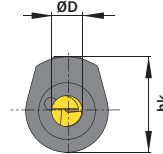


Scan
QR-Code

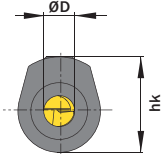
Oder besuchen Sie // Or Visit
www.simtek.info/cp/952



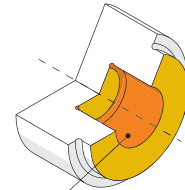
A...R
Kühlmittelzufuhr für rechte Werkzeuge
Through coolant supply for right hand tools



A...L
Kühlmittelzufuhr für linke Werkzeuge
Through coolant supply for left hand tools



A...T
Innere Kühlmittelzufuhr durch die Schneide
Through coolant supply through the insert



- Hauptsächlich geeignet für diese Flächen
Mainly designed for these surfaces
- Je nach Schneidplatte ebenfalls möglich
Also possible depending on insert type

ØD	ØDg6	Artikelnummer Part number	Webcode www.simtek.com/webcode	h	hk	L1	LK	Ls	Anzahl Spannflächen Number of flats	Schraube Screw	Schraubenschlüssel Screw driver	Connectcode www.simtek.com/code
mm	mm			mm	mm	mm	mm	mm				

◀ Fortgesetzte Tabelle Continued Table **Verwandte Werkzeuge finden Sie auch auf der vorhergehenden Seite!**
Related items can be found on the previous page as well!

▼ ØD = 4,0 mm												
4,0	10,0	A04.0010 R/L	R AUSB L AUSC	8,0	14,5	65,0	14,0	45,0	2	A M6x7,5 T15F	T15F	R A04.R L A04.L
4,0	10,0	A04.0010 T	AUSD	8,5	14,5	65,0	14,0	36,0	2	A M6x7,5 T15F	T15F	A04.L A04.R A04T
▼ ØD = 5,0 mm												
5,0	10,0	A05.0010 R/L	R AUS9 L AUTA	8,0	15,0	65,0	14,0	45,0	2	A M6x7,5 T15F	T15F	R A05.R L A05.L
5,0	10,0	A05.0010 T	AUTB	8,5	15,0	65,0	14,0	36,0	2	A M6x7,5 T15F	T15F	A05.L A05.R A05T

Verwandte Werkzeuge finden Sie auch auf der folgenden Seite!
Related items can be found on the following page as well!

▶ Fortgesetzte Tabelle Continued Table

█ Bestellbeispiel // Order example: **A04.0010 T**

Klemmhalter, Innenbearbeitung, Rundschaft

Rundschaft mit innerer Kühlmittelzufuhr für die Größe A04.
Vier Kühlmittelzufuhrarten je nach Bedarf einstellbar.

Toolholder, Internal Applications, Round Shank

Round shank with through coolant for size A04.
Four different types of through coolant supply can be realized as required.

Anzugsmoment (Schraube) // Tightening torque (screw)

7,0 Nm

Bitte Hinweise im Anhang beachten // Please read add. notes

MASTER (Seite/Page 137)



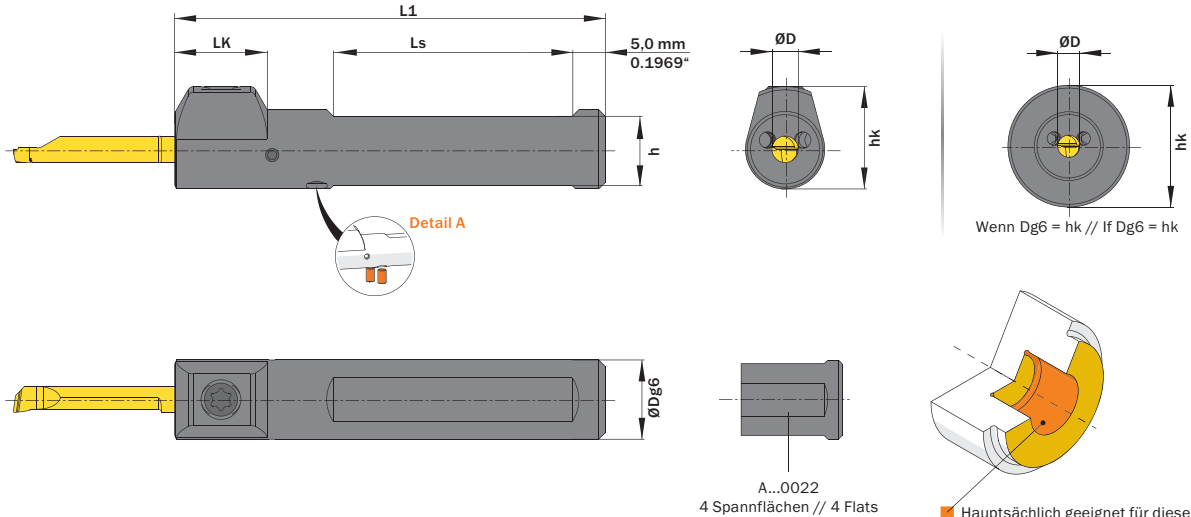
Legende
Legend

139



Scan
QR-Code

Oder besuchen Sie // Or Visit
www.simtek.info/cp/1200



A...0022
4 Spannflächen // 4 Flats

- Hauptsächlich geeignet für diese Flächen
Mainly designed for these surfaces
- Je nach Schneidplatte ebenfalls möglich
Also possible depending on insert type

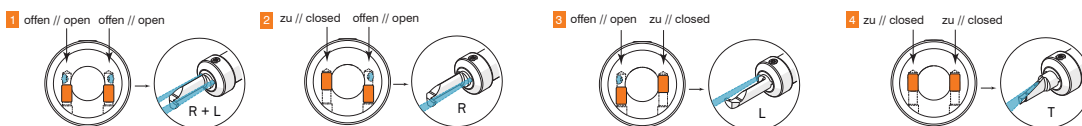
ØD	ØDg6	Artikelnummer Part number	Webcode www.simtek.com/webcode	h	hk	L1	LK	Ls	Anzahl Spannflächen Number of flats	Schraube Screw	Schraubenschlüssel Screw driver	Connectcode www.simtek.com/code
mm	mm			mm	mm	mm	mm	mm				
4,0	12,0	A04.0012 T	AUQY	10,5	15,5	70,0	14,0	41,0	2	AM6x7,5 T15F	T15F	A04.L A04.R A04C.L A04C.R A04T
4,0	12,7	A04.0.500 T	A5H9	11,0	15,85	70,0	41,0	41,0	2	AM6x7,5 T15F	T15F	
4,0	15,875	A04.0.625 T	A5H7	11,0	17,44	75,0	14,0	46,0	2	AM6x7,5 T15F	T15F	
4,0	16,0	A04.0.0016 T	AUQ1	14,0	17,5	75,0	14,0	46,0	2	AM6x7,5 T15F	T15F	
4,0	19,05	A04.0.750 T	AUSA	17,05	19,05	110,0	-	81,0	2	AM6x7,5 T15F	T15F	
4,0	20,0	A04.0020 T	AUSP	18,0	20,0	90,0	-	61,0	2	AM6x7,5 T15F	T15F	
4,0	22,0	A04.0022 T	AUST	20,0	22,0	110,0	-	90,0	4	AM6x7,5 T15F	T15F	
4,0	25,0	A04.0025 T	AUSW	23,0	25,0	110,0	-	90,0	2	AM6x7,5 T15F	T15F	
4,0	25,4	A04.1.000 T	AUSK	23,39	25,4	110,0	-	90,0	2	AM6x7,5 T15F	T15F	

Verwandte Werkzeuge finden Sie auch auf der folgenden Seite!
Related Items can be found on the following page as well!

Fortgesetzte Tabelle
Continued Table

Bestellbeispiel // Order example: **A04.0016 T**

Detail A | 1 Halter - 4 Kühlmittelzufuhrarten // 1 Toolholder - 4 types of coolant supply



Klemmhalter, Innenbearbeitung, Rundschaft

Rundschaft mit innerer Kühlmittelzufuhr für die Größe A05.
Vier Kühlmittelzufuhrarten je nach Bedarf einstellbar.

Toolholder, Internal Applications, Round Shank

Round shank with through coolant for size A05.
Four different types of through coolant supply can be realized as required.

Anzugsmoment (Schraube) // Tightening torque (screw)

7,0 Nm

Bitte Hinweise im Anhang beachten // Please read add. notes

MASTER (Seite/Page 137)

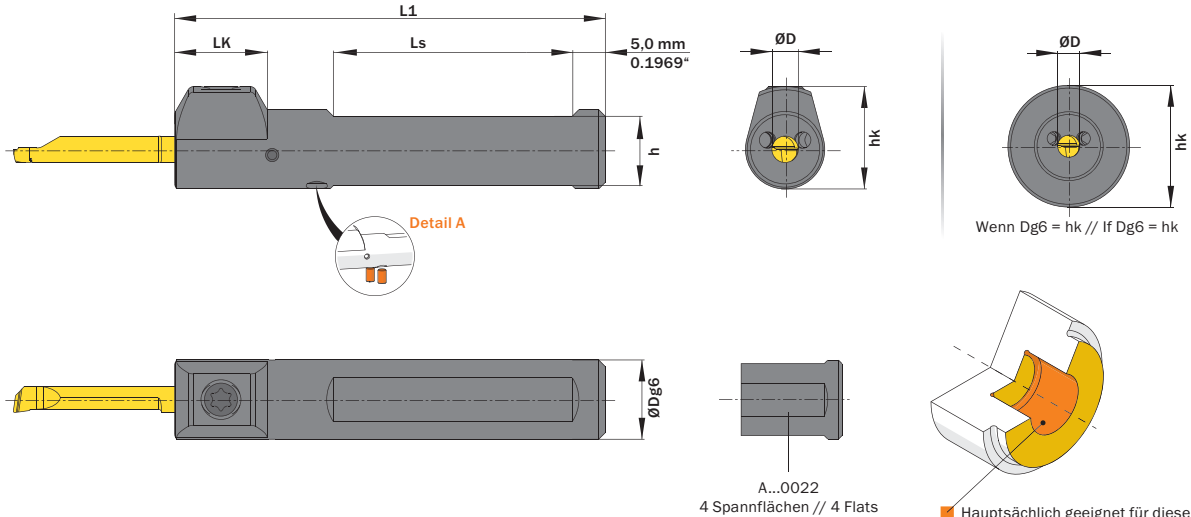


Legende
Legend **139**



Scan
QR-Code

Oder besuchen Sie // Or Visit
www.simtek.info/cp/1201



■ Hauptsächlich geeignet für diese Flächen
Mainly designed for these surfaces
■ Je nach Schneidplatte ebenfalls möglich
Also possible depending on insert type

ØD	ØDg6	Artikelnummer Part number	Webcode www.simtek.com/webcode	h	hk	L1	LK	Ls	Anzahl Spannflächen Number of flats	Schraube Screw	Schraubenschlüssel Screw driver	Connectcode www.simtek.com/code
mm	mm			mm	mm	mm	mm	mm				

Fortgesetzte Tabelle
Continued Table

Verwandte Werkzeuge finden Sie auch auf der vorhergehenden Seite!
Related items can be found on the previous page as well!

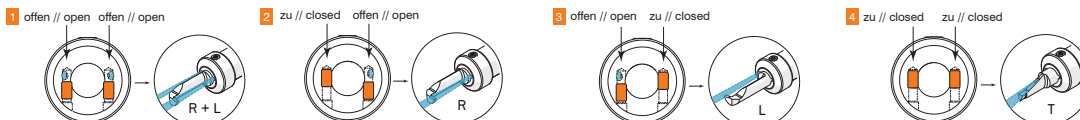
5,0	12,0	A05.0012 T	AUSZ	10,5	16,0	70,0	14,0	41,0	2	A M6x7,5 T15F	T15F	A05.L A05.R A05.T
5,0	12,7	A05.0.500 T	AUS2	11,2	16,35	70,0	14,0	41,0	2	A M6x7,5 T15F	T15F	A05.L A05.R A05.T inch
5,0	15,875	A05.0.625 T	AZMU	13,88	17,94	75,0	14,0	46,0	2	A M6x7,5 T15F	T15F	A05.L A05.R A05.T inch
5,0	16,0	A05.0016 T	AUTE	14,0	18,0	75,0	14,0	46,0	2	A M6x7,5 T15F	T15F	A05.L A05.R A05.T
5,0	19,05	A05.0.750 T	AUS8	17,05	19,05	110,0	-	81,0	2	A M6x7,5 T15F	T15F	A05.L A05.R A05.T inch
5,0	20,0	A05.0020 T	AUTQ	18,0	20,0	90,0	-	61,0	2	A M6x7,5 T15F	T15F	A05.L A05.R A05.T
5,0	22,0	A05.0022 T	AUTH	20,0	22,0	110,0	-	90,0	4	A M6x7,5 T15F	T15F	A05.L A05.R A05.T
5,0	25,0	A05.0025 T	AUTM	23,0	25,0	110,0	-	90,0	2	A M6x7,5 T15F	T15F	A05.L A05.R A05.T
5,0	25,4	A05.1.000 T	AUTX	23,4	25,4	110,0	-	90,0	2	A M6x7,5 T15F	T15F	A05.L A05.R A05.T inch

Verwandte Werkzeuge finden Sie auch auf der folgenden Seite!
Related items can be found on the following page as well!

Fortgesetzte Tabelle
Continued Table

Bestellbeispiel // Order example: **A05.0016 T**

Detail A | 1 Halter - 4 Kühlmittelzufuhrarten // 1 Toolholder - 4 types of coolant supply



Klemmhalter, Innenbearbeitung, Rundschaft

Rundschaft mit innerer Kühlmittelzufuhr für die Größe A06.
Vier Kühlmittelzufuhrarten je nach Bedarf einstellbar.

Toolholder, Internal Applications, Round Shank

Round shank with through coolant for size A06.
Four different types of through coolant supply can be realized as required.

Anzugsmoment (Schraube) // Tightening torque (screw)

7,0 Nm

Bitte Hinweise im Anhang beachten // Please read add. notes

MASTER (Seite/Page 137)



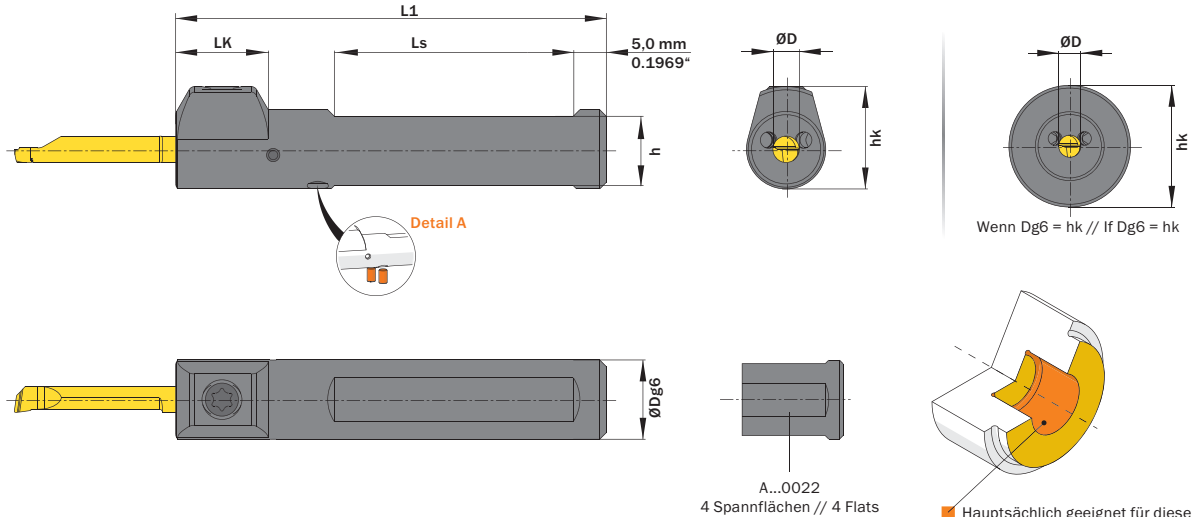
Legende
Legend

139



Scan
QR-Code

Oder besuchen Sie // Or Visit
www.simtek.info/cp/1202



ØD	ØDg6	Artikelnummer Part number	Webcode www.simtek.com/webcode	h	hk	L1	LK	Ls	Anzahl Spannflächen Number of flats	Schraube Screw	Schraubenschlüssel Screw driver	Connectcode www.simtek.com/code
mm	mm			mm	mm	mm	mm	mm				

Fortgesetzte Tabelle
Continued Table

Verwandte Werkzeuge finden Sie auch auf der vorhergehenden Seite!
Related items can be found on the previous page as well!

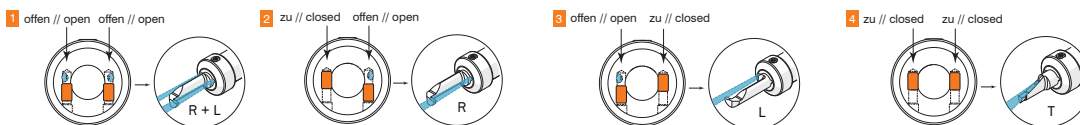
6,0	12,0	A06.0012 T	AUT9	10,5	16,5	70,0	14,0	41,0	2	A M6x7,5 T15F	T15F	A06.L A06.R A06T
6,0	15,875	A06.0.625 T	AUT0	13,88	18,44	75,0	14,0	46,0	2	A M6x7,5 T15F	T15F	A06.L A06.R A06T inch
6,0	16,0	A06.0016 T	AUUC	14,0	18,5	75,0	14,0	46,0	2	A M6x7,5 T15F	T15F	A06.L A06.R A06T
6,0	19,05	A06.0.750 T	AUT6	17,05	19,05	110,0	14,0	81,0	2	A M6x7,5 T15F	T15F	A06.L A06.R A06T inch
6,0	20,0	A06.0020 T	AUUN	18,0	20,0	90,0	14,0	61,0	2	A M6x7,5 T15F	T15F	A06.L A06.R A06T
6,0	22,0	A06.0022 T	AUUF	20,0	22,0	110,0	-	90,0	4	A M6x7,5 T15F	T15F	A06.L A06.R A06T
6,0	25,0	A06.0025 T	AUUJ	23,0	25,0	110,0	-	90,0	2	A M6x7,5 T15F	T15F	A06.L A06.R A06T
6,0	25,4	A06.1.000 T	AUUU	23,4	25,4	110,0	-	90,0	2	A M6x7,5 T15F	T15F	A06.L A06.R A06T inch

Verwandte Werkzeuge finden Sie auch auf der folgenden Seite!
Related items can be found on the following page as well!

Fortgesetzte Tabelle
Continued Table

Bestellbeispiel // Order example: **A06.0016 T**

Detail A | 1 Halter - 4 Kühlmittelzufuhrarten // 1 Toolholder - 4 types of coolant supply



Klemmhalter, Innenbearbeitung, Rundschaft

Rundschaft mit innerer Kühlmittelzufuhr für die Größe A07.
Vier Kühlmittelzufuhrarten je nach Bedarf einstellbar.

Toolholder, Internal Applications, Round Shank

Round shank with through coolant for size A07.
Four different types of through coolant supply can be realized as required.

Anzugsmoment (Schraube) // Tightening torque (screw)

7,0 Nm

Bitte Hinweise im Anhang beachten // Please read add. notes

MASTER (Seite/Page 137)



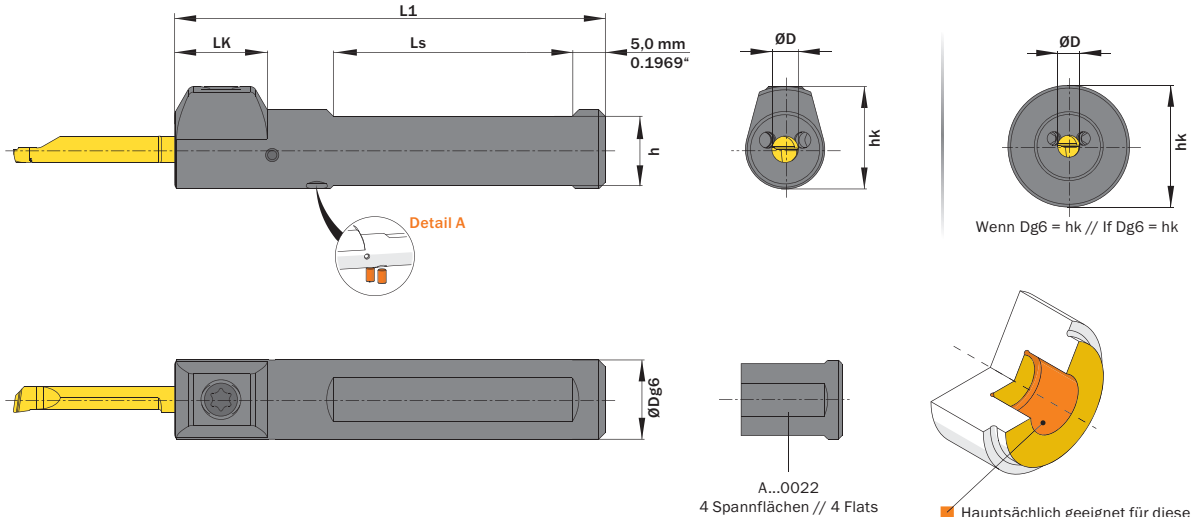
Legende
Legend

139



Scan
QR-Code

Oder besuchen Sie // Or Visit
www.simtek.info/cp/1203



- Hauptsächlich geeignet für diese Flächen
Mainly designed for these surfaces
- Je nach Schneidplatte ebenfalls möglich
Also possible depending on insert type

ØD	ØDg6	Artikelnummer Part number	Webcode www.simtek.com/webcode	h	hk	L1	LK	Ls	Anzahl Spannflächen Number of flats	Schraube Screw	Schraubenschlüssel Screw driver	Connectcode www.simtek.com/code
mm	mm			mm	mm	mm	mm	mm				

Fortgesetzte Tabelle
Continued Table

Verwandte Werkzeuge finden Sie auch auf der vorhergehenden Seite!
Related items can be found on the previous page as well!

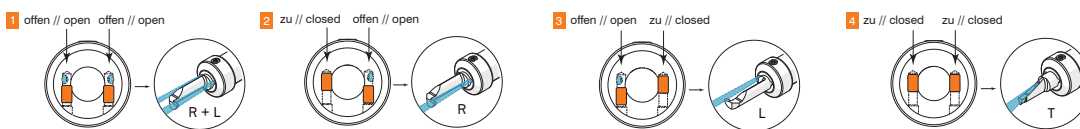
7,0	15,875	A07.0.625 T	AUU1	13,88	18,94	75,0	14,0	46,0	2	A M6x7,5 T15F	T15F	A07L A07R A07T	Inch
7,0	16,0	A07.0016 T	AUU4	14,0	19,0	75,0	14,0	46,0	2	A M6x7,5 T15F	T15F	A07L A07R A07T	Inch
7,0	19,05	A07.0.750 T	AUUY	17,05	21,0	110,0	14,0	81,0	2	A M6x7,5 T15F	T15F	A07L A07R A07T	Inch
7,0	20,0	A07.0020 T	AUVD	18,0	22,0	90,0	14,0	61,0	2	A M6x7,5 T15F	T15F	A07L A07R A07T	Inch
7,0	22,0	A07.0022 T	AUU7	20,0	22,0	110,0	-	90,0	4	A M6x7,5 T15F	T15F	A07L A07R A07T	Inch
7,0	25,0	A07.0025 T	AUVA	23,0	25,0	110,0	-	90,0	2	A M6x7,5 T15F	T15F	A07L A07R A07T	Inch
7,0	25,4	A07.1.000 T	AUVK	23,4	25,4	110,0	-	90,0	2	A M6x7,5 T15F	T15F	A07L A07R A07T	Inch

Verwandte Werkzeuge finden Sie auch auf der folgenden Seite!
Related items can be found on the following page as well!

Fortgesetzte Tabelle
Continued Table

Bestellbeispiel // Order example: **A07.0016 T**

Detail A | 1 Halter - 4 Kühlmittelzufuhrarten // 1 Toolholder - 4 types of coolant supply



Klemmhalter, Innenbearbeitung, Rundschaft

Rundschaft mit innerer Kühlmittelzufuhr für die Größe A08.
 Vier Kühlmittelzufuhrarten je nach Bedarf einstellbar.

Toolholder, Internal Applications, Round Shank

Round shank with through coolant for size A08.
 Four different types of through coolant supply can be realized as required.

Anzugsmoment (Schraube) // Tightening torque (screw)

7,0 Nm

Bitte Hinweise im Anhang beachten // Please read add. notes

MASTER (Seite/Page 137)



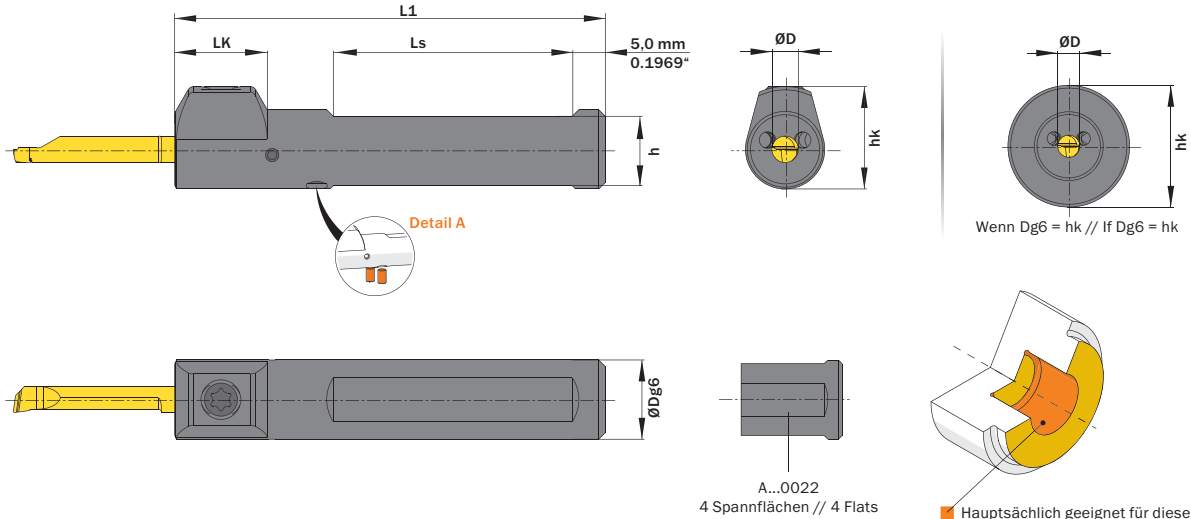
Legende
 Legend

139



Scan
 QR-Code

Oder besuchen Sie // Or Visit
www.simtek.info/cp/1204



- **Hauptsächlich geeignet für diese Flächen**
 Mainly designed for these surfaces
- **Je nach Schneidplatte ebenfalls möglich**
 Also possible depending on insert type

ØD	ØDg6	Artikelnummer Part number	Webcode www.simtek.com/webcode	h	hk	L1	LK	Ls	Anzahl Spannflächen Number of flats	Schraube Screw	Schraubenschlüssel Screw driver	Connectcode www.simtek.com/code
mm	mm			mm	mm	mm	mm	mm				

◀ Fortgesetzte Tabelle
 Continued Table

Verwandte Werkzeuge finden Sie auch auf der vorhergehenden Seite!
 Related items can be found on the previous page as well!

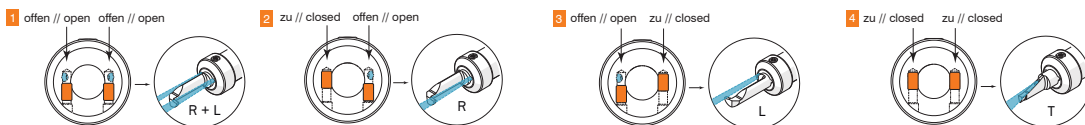
8,0	15,875	A08.0.625 T	AUVP	13,88	19,44	75,0	14,0	46,0	2	A M6x7,5 T15F	T15F	A08 A08T	Inch
8,0	16,0	A08.0016 T	AUVW	14,0	19,5	75,0	14,0	46,0	2	A M6x7,5 T15F	T15F	A08 A08T	
8,0	19,05	A08.0.750 T	AUVT	17,05	24,0	110,0	14,0	81,0	2	A M6x7,5 T15F	T15F	A08 A08T	Inch
8,0	20,0	A08.0020 T	AUV2	18,0	25,0	90,0	14,0	61,0	2	A M6x7,5 T15F	T15F	A08 A08T	
8,0	22,0	A08.0022 T	AØYF	20,0	22,0	110,0	-	90,0	4	A M6x7,5 T15F	T15F	A08 A08T	
8,0	25,0	A08.0025 T	AUVZ	23,0	25,0	110,0	-	90,0	2	A M6x7,5 T15F	T15F	A08 A08T	
8,0	25,4	A08.1.000 T	AUV5	23,4	25,4	110,0	-	90,0	2	A M6x7,5 T15F	T15F	A08 A08T	Inch

Verwandte Werkzeuge finden Sie auch auf der folgenden Seite!
 Related items can be found on the following page as well!

Fortgesetzte Tabelle
 Continued Table ▶

Bestellbeispiel // Order example: **A08.0016 T**

Detail A | 1 Halter - 4 Kühlmittelzufuhrarten // 1 Toolholder - 4 types of coolant supply



Klemmhalter, Innenbearbeitung, Rundschaft

Rundschaft mit innerer Kühlmittelzufuhr für die Größe A10.
Vier Kühlmittelzufuhrarten je nach Bedarf einstellbar.

Toolholder, Internal Applications, Round Shank

Round shank with through coolant for size A10.
Four different types of through coolant supply can be realized as required.

Anzugsmoment (Schraube) // Tightening torque (screw)

7,0 Nm

Bitte Hinweise im Anhang beachten // Please read add. notes

MASTER (Seite/Page 137)



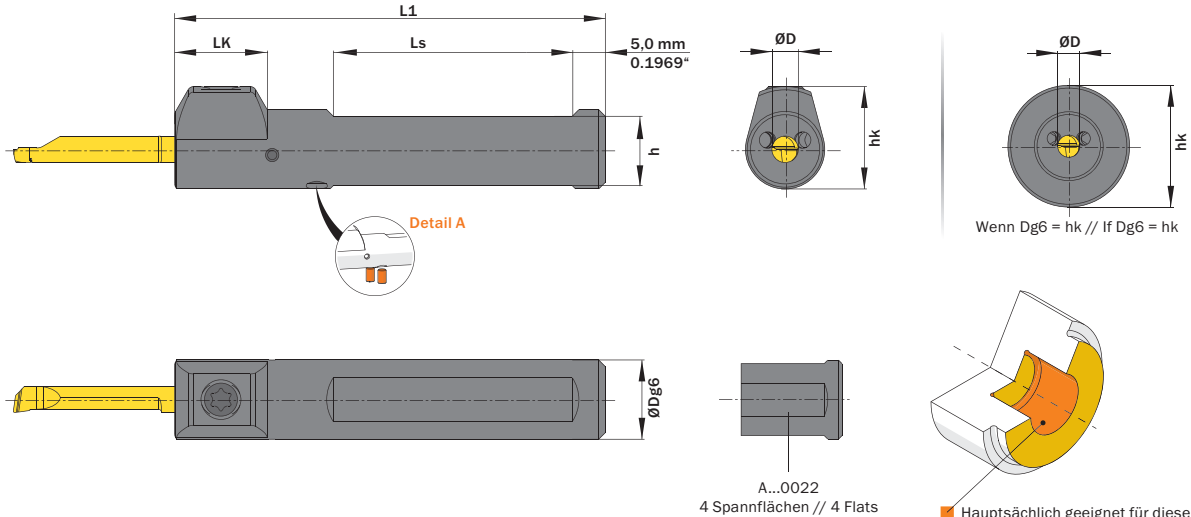
Legende
Legend

139



Scan
QR-Code

Oder besuchen Sie // Or Visit
www.simtek.info/cp/1205



- Hauptsächlich geeignet für diese Flächen
Mainly designed for these surfaces
- Je nach Schneidplatte ebenfalls möglich
Also possible depending on insert type

ØD	ØDg6	Artikelnummer Part number	Webcode www.simtek.com/webcode	h	hk	L1	LK	Ls	Anzahl Spannflächen Number of flats	Schraube Screw	Schraubenschlüssel Screw driver	Connectcode www.simtek.com/code
mm	mm			mm	mm	mm	mm	mm				

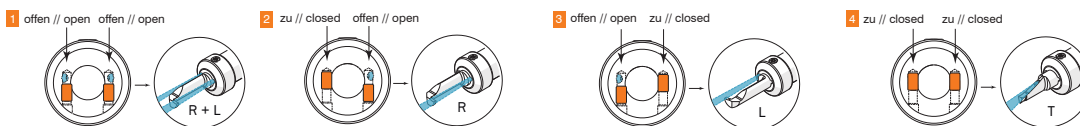
Fortgesetzte Tabelle
Continued Table

Verwandte Werkzeuge finden Sie auch auf der vorhergehenden Seite!
Related items can be found on the previous page as well!

10,0	19,05	A10.0.750 T	AUV8	17,05	24,0	110,0	14,0	81,0	2	A M6x7,5T15F	T15F	A10.L A10.R A10T	Inch
10,0	20,0	A10.0020 T	AUWB	18,0	25,0	90,0	14,0	61,0	2	A M6x7,5T15F	T15F	A10.L A10.R A10T	
10,0	22,0	A10.0022 T	AØ74	20,94	25,0	110,0	14,0	90,0	4	A M6x7,5T15F	T15F	A10.L A10.R A10T	upd
10,0	25,0	A10.0025 T	AUWE	23,0	25,0	110,0	-	90,0	2	A M6x7,5T15F	T15F	A10.L A10.R A10T	
10,0	25,4	A10.1.000 T	AUWH	23,4	25,4	110,0	-	90,0	2	A M6x7,5T15F	T15F	A10.L A10.R A10T	new Inch

Bestellbeispiel // Order example: **A10.0020 T**

Detail A | 1 Halter – 4 Kühlmittelzufuhrarten // 1 Toolholder – 4 types of coolant supply



Kleinteilebearbeitung // Small Part Machining
 simturn AX > Trägerwerkzeug // Toolholder



Klemmhalter, Innenbearbeitung, Rundschaft, „ME“

Rundschaft aus Hartmetall, besonders geeignet zur Erhöhung der möglichen Auskrantung mit unserem innovativen ME-Spannprinzip. Das ME-Spannsystem bietet kraftschlüssiges Spannen und dadurch optimale Präzision und Stabilität.

Toolholder, Internal Applications, Round Shank „ME“

Carbide round shank, suitable for extending the overall tool reach equipped with our innovative ME-clamping system. The ME-system provides form-fit clamping along with higher precision and stability.

Anzugsmoment (Schraube) // Tightening torque (screw)

10,0 Nm - 15,0 Nm

Bitte Hinweise im Anhang beachten // Please read add. notes

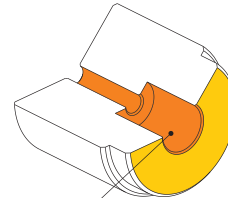
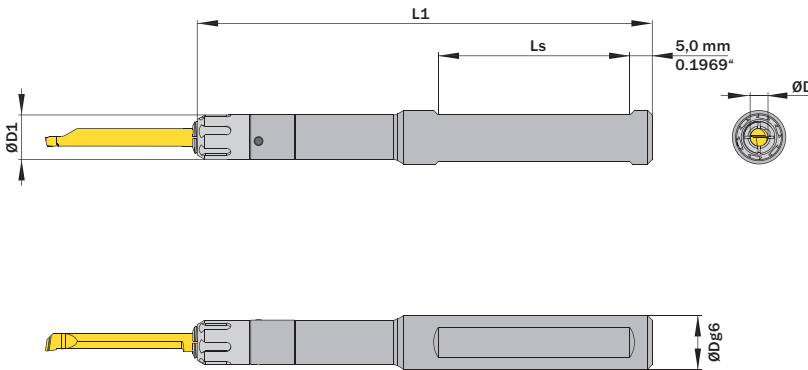
MASTER (Seite/Page 137)

Scan QR-Code Oder besuchen Sie // Or Visit www.simtek.info/cp/1197

Legende Legend **139**



Entdecken Sie unseren simturn AX Halter „ME“. Discover our simturn AX toolholder „ME“.



- Hauptsächlich geeignet für diese Flächen
Mainly designed for these surfaces
- Je nach Schneidplatte ebenfalls möglich
Also possible depending on insert type

Abbildung zeigt / Drawing shows: A04.0012.10.42.ME HM R

ØD	ØDg6	ØD1	Artikelnummer Part number	Webcode www.simtek.com/webcode	L1	LK	Ls	Standard Mutter Standard screw nut	Schlüssel Key	Connectcode www.simtek.com/ccode
mm	mm	mm			mm	mm	mm			

◀ Fortgesetzte Tabelle Continued Table **Verwandte Werkzeuge finden Sie auch auf der vorhergehenden Seite!**
 Related items can be found on the previous page as well!

4,0	12,0	10,0	A04.0012.10.42.ME HM R/L	R AZEE L AZED	103,0	45,0	48,5	A00.K.73.12.10	A00.S.08.91	R L	A04.R A04C.R A04.L A04C.L	upd
-----	------	------	---------------------------------	---------------	-------	------	------	----------------	-------------	--------	------------------------------	-----

Verwandte Werkzeuge finden Sie auch auf der folgenden Seite!
 Related items can be found on the following page as well!

Fortgesetzte Tabelle Continued Table ▶

■ Bestellbeispiel // Order example: **A04.0012.10.42.ME HM R** (R = Rechte Ausführung // Right hand version)

Klemmhalter, Innenbearbeitung, Rundschaft, „ME“

Rundschaft aus Hartmetall, besonders geeignet zur Erhöhung der möglichen Auskragung mit unserem innovativen ME-Spannprinzip. Das ME-Spannsystem bietet kraftschlüssiges Spannen und dadurch optimale Präzision und Stabilität. Vier Kühlmittelzufuhrarten je nach Bedarf einstellbar.

Toolholder, Internal Applications, Round Shank „ME“

Carbide round shank, suitable for extending the overall tool reach equipped with our innovative ME-clamping system. The ME-system provides force-fitted clamping along with higher precision and stability. Four different types of through coolant supply can be realized as required.

Anzugsmoment (Schraube) // Tightening torque (screw)

10,0 Nm - 15,0 Nm

Bitte Hinweise im Anhang beachten // Please read add. notes

MASTER (Seite/Page 137)



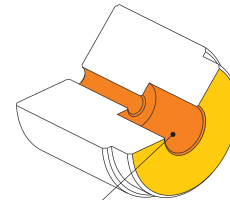
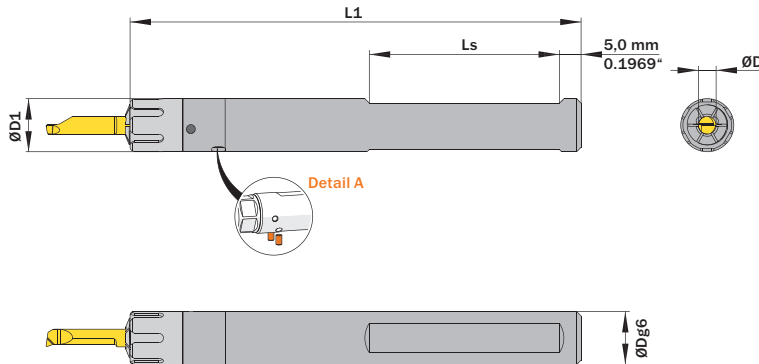
TW HM ME Legende Legend **139**

Scan QR-Code

Oder besuchen Sie // Or Visit www.simtek.info/cp/1196



Entdecken Sie unseren simturn AX Halter „ME“. Discover our simturn AX toolholder „ME“.



- **Hauptsächlich geeignet für diese Flächen**
Mainly designed for these surfaces
- **Je nach Schneidplatte ebenfalls möglich**
Also possible depending on insert type

Abbildung zeigt / Drawing shows: A04.0012.12.42 ME HM T

ØD	ØDg6	ØD1	Artikelnummer Part number	Webcode www.simtek.com/webcode	L1	Ls	Standard Mutter Standard screw nut	Schlüssel Key	Connectcode www.simtek.com/code
mm	mm	mm			mm	mm			

Fortgesetzte Tabelle
Continued Table

Verwandte Werkzeuge finden Sie auch auf der vorhergehenden Seite!
Related Items can be found on the previous page as well!

▼ ØD = 4,0 mm

4,0	12,0	12,0	A04.0012.12.42.ME HM T	AY69	103,0	43,0	A00.K.93.12.12	A00.S.10.103	A04.L A04.R A04CL	upd
4,0	12,7	12,7	A04.0.500.12.42.ME HM T	A09E	103,0	43,0	A00.K.93.12.12	A00.S.10.103	A04C.R A04T	upd inch

▼ ØD = 5,0 mm

5,0	12,0	12,0	A05.0012.12.42.ME HM T	AY7E	108,0	43,0	A00.K.93.12.12	A00.S.10.103	A05.L A05.R A05T	upd
5,0	12,7	12,7	A05.0.500.12.42.ME HM T	A09F	108,0	43,0	A00.K.93.12.12	A00.S.10.103	A05.L A05.R A05T	upd inch

Verwandte Werkzeuge finden Sie auch auf der folgenden Seite!
Related Items can be found on the following page as well!

Fortgesetzte Tabelle
Continued Table

Bestellbeispiel // Order example: **A04.0012.12.42.ME HM T**

Detail A | 1 Halter – 4 Kühlmittelzufuhrarten // 1 Toolholder – 4 types of coolant supply



Kleinteilebearbeitung // Small Part Machining
 simturn AX > Trägerwerkzeug // Toolholder



Klemmhalter, Innenbearbeitung, Rundschaft, „ME“

Rundschaft aus Hartmetall, besonders geeignet zur Erhöhung der möglichen Auskragung mit unserem innovativen ME-Spannprinzip. Das ME-Spannsystem bietet kraftschlüssiges Spannen und dadurch optimale Präzision und Stabilität. Vier Kühlmittelzufuhrarten je nach Bedarf einstellbar.

Toolholder, Internal Applications, Round Shank „ME“

Carbide round shank, suitable for extending the overall tool reach equipped with our innovative ME-clamping system. The ME-system provides force-fitted clamping along with higher precision and stability. Four different types of through coolant supply can be realized as required.

Anzugsmoment (Schraube) // Tightening torque (screw)

10,0 Nm - 15,0 Nm

Bitte Hinweise im Anhang beachten // Please read add. notes

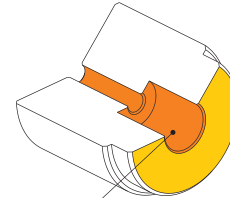
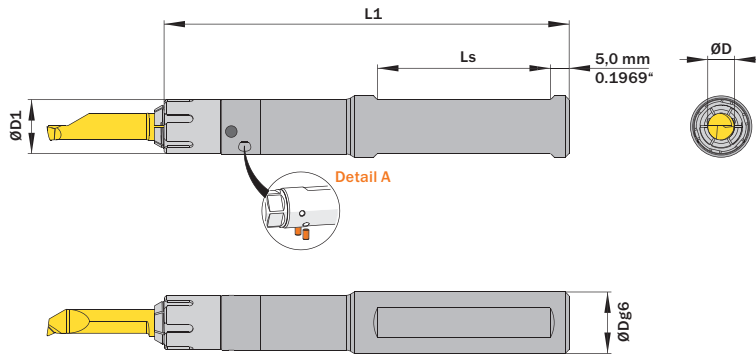
MASTER (Seite/Page 137)

Scan QR-Code Oder besuchen Sie // Or Visit www.simtek.info/cp/1218

Legende Legend **139**



Entdecken Sie unseren simturn AX Halter „ME“. Discover our simturn AX toolholder „ME“.



- Hauptsächlich geeignet für diese Flächen
 Mainly designed for these surfaces
- Je nach Schneidplatte ebenfalls möglich
 Also possible depending on insert type

Abbildung zeigt / Drawing shows: A07.0016.14.50.ME HM T

ØD	ØDg6	ØD1	Artikelnummer Part number	Webcode www.simtek.com/webcode	L1	Ls	Standard Mutter Standard screw nut	Schlüssel Key	Connectcode www.simtek.com/code
mm	mm	mm			mm	mm			

Fortgesetzte Tabelle
Continued Table

Verwandte Werkzeuge finden Sie auch auf der vorhergehenden Seite!
Related Items can be found on the previous page as well!

▼ ØD = 6,0 mm									
6,0	16,0	14,0	A06.0016.14.50.ME HM T	AZE6	108,0	45,0	A00.K.113.15.14	A00.S.12.122	A06.L A06.R A06T upd
▼ ØD = 7,0 mm									
7,0	16,0	14,0	A07.0016.14.50.ME HM T	AZEW	108,0	45,0	A00.K.113.15.14	A00.S.12.122	A07.L A07.R A07T upd

Bestellbeispiel // Order example: **A06.0016.14.50.ME HM T**

Detail A | 1 Halter - 4 Kühlmittelzufuhrarten // 1 Toolholder - 4 types of coolant supply



Klemmhalter, Innenbearbeitung, Rundschaft, „ME“

Rundschaft aus Stahl, mit unserem innovativen ME-Spannprinzip. Das ME-Spannsystem bietet kraftschlüssiges Spannen und dadurch optimale Präzision und Stabilität. Vier Kühlmittelzufuhrarten je nach Bedarf einstellbar.

Toolholder, Internal Applications, Round Shank „ME“

Steel round shank, equipped with our innovative ME-clamping system. The ME-system provides force-fitted clamping along with higher precision and stability. Four different types of through coolant supply can be realized as required.

Anzugsmoment (Schraube) // Tightening torque (screw)

15,0 Nm - 25,0 Nm

Bitte Hinweise im Anhang beachten // Please read add. notes

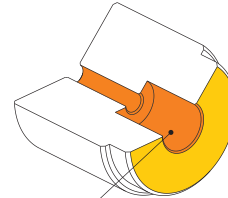
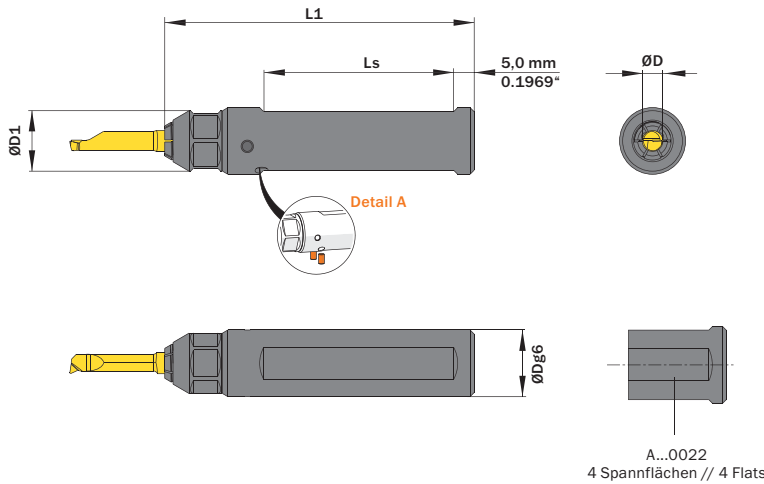
MASTER (Seite/Page 137), T02 (Seite/Page 138)

Scan QR-Code Oder besuchen Sie // Or Visit www.simtek.info/cp/1164

Legende Legend **139**



Entdecken Sie unseren simturn AX Halter „ME“. Discover our simturn AX toolholder „ME“.



- **Hauptsächlich geeignet für diese Flächen**
Mainly designed for these surfaces
- **Je nach Schneidplatte ebenfalls möglich**
Also possible depending on insert type

Abbildung zeigt / Drawing shows: A04.0016.ME ST T

ØD	ØDg6	Artikelnummer Part number	Webcode www.simtek.com/webcode	ØD1	L1	Ls	Standard Mutter Standard screw nut	Connectcode www.simtek.com/ccode
mm	mm			mm	mm	mm		
4,0	12,0	A04.0012.ME ST T	AY7A	14,5	70,0	42,0	A00.K.14.12.88	A04.L A04.R A04CL A04C.R A04T
4,0	12,7	A04.0.500.ME ST T	A0YH	14,5	70,0	42,0	A00.K.14.12.88	
4,0	15,88	A04.0.625.ME ST T	AZN2	14,5	75,0	47,0	A00.K.14.12.88	
4,0	16,0	A04.0016.ME ST T	AY7B	14,5	75,0	47,0	A00.K.14.12.88	
4,0	19,05	A04.0.750.ME ST T	AZNH	14,5	110,0	78,0	A00.K.14.12.88	
4,0	20,0	A04.0020.ME ST T	AY7C	14,5	90,0	58,0	A00.K.14.12.88	
4,0	22,0	A04.0022.ME ST T	AZJ1	14,5	110,0	80,0	A00.K.14.12.88	
4,0	23,0	A04.0023.ME ST T	AZJ2	14,5	110,0	80,0	A00.K.14.12.88	
4,0	25,0	A04.0025.ME ST T	AY7D	14,5	110,0	80,0	A00.K.14.12.88	
4,0	25,4	A04.1.000.ME ST T	A0YY	14,5	110,0	80,0	A00.K.14.12.88	

Verwandte Werkzeuge finden Sie auch auf der folgenden Seite!
Related Items can be found on the following page as well!

Fortgesetzte Tabelle
Continued Table

Bestellbeispiel // Order example: **A04.0016.ME ST T**

Detail A | 1 Halter - 4 Kühlmittelzufuhrarten // 1 Toolholder - 4 types of coolant supply



Klemmhalter, Innenbearbeitung, Rundschaft, „ME“

Rundschaft aus Stahl, mit unserem innovativen ME-Spannprinzip. Das ME-Spannsystem bietet kraftschlüssiges Spannen und dadurch optimale Präzision und Stabilität. Vier Kühlmittelzufuhrarten je nach Bedarf einstellbar.

Toolholder, Internal Applications, Round Shank „ME“

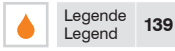
Steel round shank, equipped with our innovative ME-clamping system. The ME-system provides force-fitted clamping along with higher precision and stability. Four different types of through coolant supply can be realized as required.

Anzugsmoment (Schraube) // Tightening torque (screw)

15,0 Nm - 25,0 Nm

Bitte Hinweise im Anhang beachten // Please read add. notes

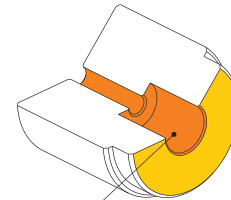
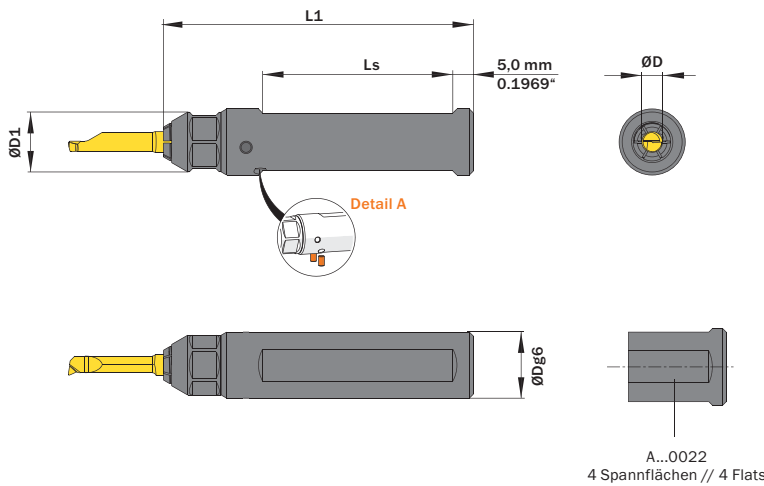
MASTER (Seite/Page 137), T02 (Seite/Page 138)



Oder besuchen Sie // Or Visit www.simtek.info/cp/1166



Entdecken Sie unseren simturn AX Halter „ME“. Discover our simturn AX toolholder „ME“.



- **Hauptsächlich geeignet für diese Flächen**
Mainly designed for these surfaces
- **Je nach Schneidplatte ebenfalls möglich**
Also possible depending on insert type

Abbildung zeigt / Drawing shows: A05.0016.ME ST T

ØD	ØDg6	Artikelnummer Part number	Webcode www.simtek.com/webcode	ØD1	L1	Ls	Standard Mutter Standard screw nut	Connectcode www.simtek.com/code
mm	mm			mm	mm	mm		

Fortgesetzte Tabelle
Continued Table

Verwandte Werkzeuge finden Sie auch auf der vorhergehenden Seite!
Related items can be found on the previous page as well!

5,0	12,0	A05.0012.ME ST T	AY7F	14,5	70,0	41,0	A00.K.14.12.88	A05.L A05.R A05T
5,0	12,7	A05.0.500.ME ST T	A0YJ	14,5	70,0	41,0	A00.K.14.12.88	A05.L A05.R A05T inch
5,0	15,875	A05.0.625.ME ST T	AZN3	14,5	75,0	46,0	A00.K.14.12.88	A05.L A05.R A05T inch
5,0	16,0	A05.0016.ME ST T	AY7G	14,5	75,0	46,0	A00.K.14.12.88	A05.L A05.R A05T
5,0	19,05	A05.0.750.ME ST T	AZNJ	14,5	110,0	78,0	A00.K.14.12.88	A05.L A05.R A05T inch
5,0	20,0	A05.0020.ME ST T	AY7H	14,5	90,0	58,0	A00.K.14.12.88	A05.L A05.R A05T
5,0	22,0	A05.0022.ME ST T	AZJ3	14,5	110,0	79,0	A00.K.14.12.88	A05.L A05.R A05T
5,0	23,0	A05.0023.ME ST T	AZJ4	14,5	110,0	79,0	A00.K.14.12.88	A05.L A05.R A05T
5,0	25,0	A05.0025.ME ST T	AY7J	14,5	110,0	79,0	A00.K.14.12.88	A05.L A05.R A05T
5,0	25,4	A05.1.000.ME ST T	A0YZ	14,5	110,0	79,0	A00.K.14.12.88	A05.L A05.R A05T inch

Verwandte Werkzeuge finden Sie auch auf der folgenden Seite!
Related items can be found on the following page as well!

Fortgesetzte Tabelle
Continued Table

Bestellbeispiel // Order example: **A05.0016.ME ST T**

Detail A | 1 Halter – 4 Kühlmittelzufuhrarten // 1 Toolholder – 4 types of coolant supply



Klemmhalter, Innenbearbeitung, Rundschaft, „ME“

Rundschaft aus Stahl, mit unserem innovativen ME-Spannprinzip. Das ME-Spannsystem bietet kraftschlüssiges Spannen und dadurch optimale Präzision und Stabilität. Vier Kühlmittelzufuhrarten je nach Bedarf einstellbar.

Toolholder, Internal Applications, Round Shank „ME“

Steel round shank, equipped with our innovative ME-clamping system. The ME-system provides force-fitted clamping along with higher precision and stability. Four different types of through coolant supply can be realized as required.

Anzugsmoment (Schraube) // Tightening torque (screw)

15,0 Nm - 25,0 Nm

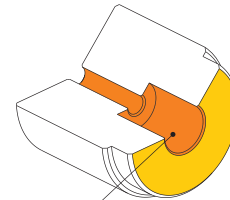
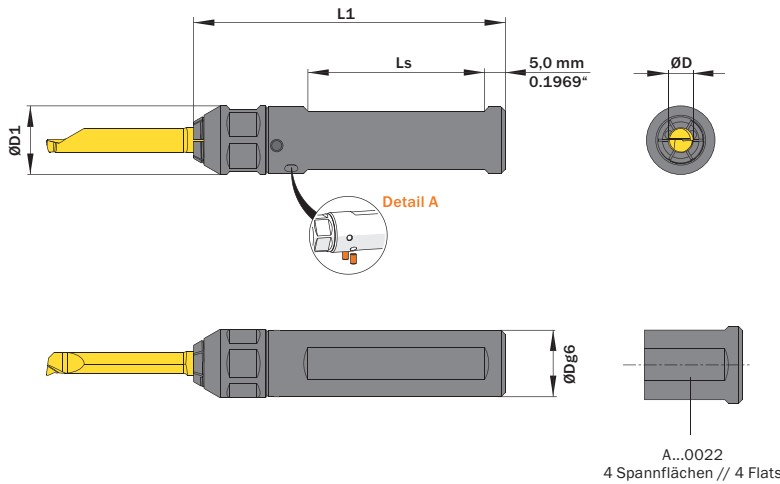
Bitte Hinweise im Anhang beachten // Please read add. notes

MASTER (Seite/Page 137), T02 (Seite/Page 138)

Scan QR-Code Oder besuchen Sie // Or Visit www.simtek.info/cp/1195



Entdecken Sie unseren simturn AX Halter „ME“. Discover our simturn AX toolholder „ME“.



- **Hauptsächlich geeignet für diese Flächen**
Mainly designed for these surfaces
- **Je nach Schneidplatte ebenfalls möglich**
Also possible depending on insert type

Abbildung zeigt / Drawing shows: A06.0016.ME ST T

ØD	ØDg6	Artikelnummer Part number	Webcode www.simtek.com/webcode	ØD1	L1	Ls	Standard Mutter Standard screw nut	Connectcode www.simtek.com/ccode
mm	mm			mm	mm	mm		

Fortgesetzte Tabelle Continued Table **Verwandte Werkzeuge finden Sie auch auf der vorhergehenden Seite!**
Related items can be found on the previous page as well!

6,0	12,0	A06.0012.ME ST T	AZJ5	16,5	70,0	37,5	A00.K.16.12.108	A06.L A06.R A06T
6,0	12,7	A06.0.500.ME ST T	A0YK	16,5	70,0	37,5	A00.K.16.12.108	A06.L A06.R A06T inch
6,0	15,875	A06.0.625.ME ST T	AZN4	16,5	75,0	42,5	A00.K.16.12.108	A06.L A06.R A06T inch
6,0	16,0	A06.0016.ME ST T	AY7M	16,5	75,0	42,5	A00.K.16.12.108	A06.L A06.R A06T
6,0	19,05	A06.0.750.ME ST T	AZNK	16,5	110,0	77,5	A00.K.16.12.108	A06.L A06.R A06T inch
6,0	20,0	A06.0020.ME ST T	AY7N	16,5	90,0	57,5	A00.K.16.12.108	A06.L A06.R A06T
6,0	22,0	A06.0022.ME ST T	AZJ6	16,5	110,0	77,5	A00.K.16.12.108	A06.L A06.R A06T
6,0	23,0	A06.0023.ME ST T	AZJ7	16,5	110,0	77,5	A00.K.16.12.108	A06.L A06.R A06T
6,0	25,0	A06.0025.ME ST T	AY7P	16,5	110,0	77,5	A00.K.16.12.108	A06.L A06.R A06T
6,0	25,4	A06.1.000.ME ST T	A0ZJ	16,5	110,0	77,5	A00.K.16.12.108	A06.L A06.R A06T inch

Verwandte Werkzeuge finden Sie auch auf der folgenden Seite!
Related Items can be found on the following page as well!

Fortgesetzte Tabelle Continued Table

Bestellbeispiel // Order example: **A06.0016.ME ST T**

Detail A | 1 Halter – 4 Kühlmittelzufuhrarten // 1 Toolholder – 4 types of coolant supply



Klemmhalter, Innenbearbeitung, Rundschaft, „ME“

Rundschaft aus Stahl, mit unserem innovativen ME-Spannprinzip. Das ME-Spannsystem bietet kraftschlüssiges Spannen und dadurch optimale Präzision und Stabilität. Vier Kühlmittelzufuhrarten je nach Bedarf einstellbar.

Toolholder, Internal Applications, Round Shank „ME“

Steel round shank, equipped with our innovative ME-clamping system. The ME-system provides force-fitted clamping along with higher precision and stability. Four different types of through coolant supply can be realized as required.

Anzugsmoment (Schraube) // Tightening torque (screw)

15,0 Nm - 25,0 Nm

Bitte Hinweise im Anhang beachten // Please read add. notes

MASTER (Seite/Page 137), T02 (Seite/Page 138)



Legende Legend **139**



Scan QR-Code

Oder besuchen Sie // Or Visit www.simtek.info/cp/1168



Entdecken Sie unseren simturn AX Halter „ME“. Discover our simturn AX toolholder „ME“.

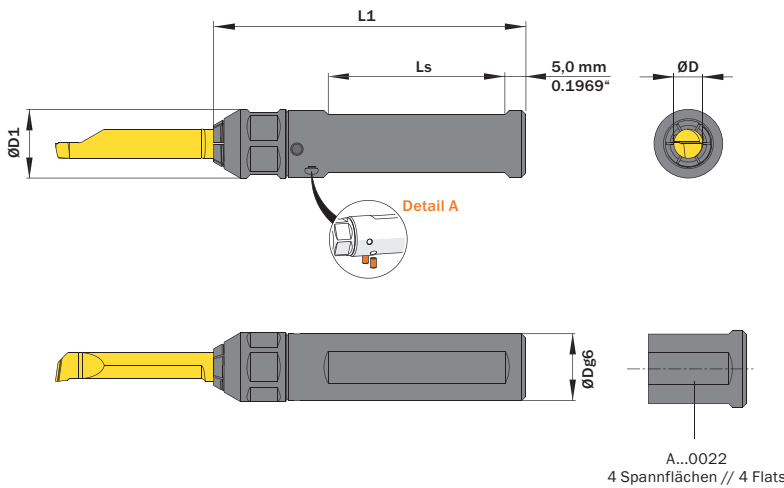
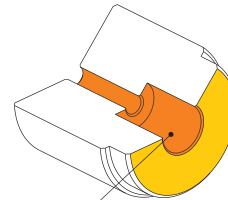


Abbildung zeigt / Drawing shows: A07.0016.ME ST T



A...0022
4 Spannflächen // 4 Flats

- **Hauptsächlich geeignet für diese Flächen**
Mainly designed for these surfaces
- **Je nach Schneidplatte ebenfalls möglich**
Also possible depending on insert type

ØD	ØDg6	Artikelnummer Part number	Webcode www.simtek.com/webcode	ØD1	L1	Ls	Standard Mutter Standard screw nut	Connectcode www.simtek.com/code
mm	mm			mm	mm	mm		

Fortgesetzte Tabelle
Continued Table

Verwandte Werkzeuge finden Sie auch auf der vorhergehenden Seite!
Related Items can be found on the previous page as well!

7,0	15,875	A07.0.625.ME ST T	AZN5	16,5	75,0	42,5	A00.K.16.12.108	A07.L A07.R A07.T	Inch
7,0	16,0	A07.0016.ME ST T	AY7Q	16,5	75,0	42,5	A00.K.16.12.108	A07.L A07.R A07.T	
7,0	19,05	A07.0.750.ME ST T	AZNM	16,5	110,0	77,5	A00.K.16.12.108	A07.L A07.R A07.T	Inch
7,0	20,0	A07.0020.ME ST T	AY7S	16,5	90,0	57,5	A00.K.16.12.108	A07.L A07.R A07.T	
7,0	22,0	A07.0022.ME ST T	AZM0	16,5	110,0	78,0	A00.K.16.12.108	A07.L A07.R A07.T	
7,0	23,0	A07.0023.ME ST T	A011	16,5	110,0	78,0	A00.K.16.12.108	A07.L A07.R A07.T	
7,0	25,0	A07.0025.ME ST T	AY7T	16,5	110,0	78,0	A00.K.16.12.108	A07.L A07.R A07.T	
7,0	25,4	A07.1.000.ME ST T	A010	16,5	110,0	78,0	A00.K.16.12.108	A07.L A07.R A07.T	Inch

Verwandte Werkzeuge finden Sie auch auf der folgenden Seite!
Related Items can be found on the following page as well!

Fortgesetzte Tabelle
Continued Table

Bestellbeispiel // Order example: **A07.0016.ME ST T**

Detail A | 1 Halter - 4 Kühlmittelzufuhrarten // 1 Toolholder - 4 types of coolant supply



Klemmhalter, Innenbearbeitung, Rundschaft, „ME“

Rundschaft aus Stahl, mit unserem innovativen ME-Spannprinzip. Das ME-Spannsystem bietet kraftschlüssiges Spannen und dadurch optimale Präzision und Stabilität. Vier Kühlmittelzufuhrarten je nach Bedarf einstellbar.

Toolholder, Internal Applications, Round Shank „ME“

Steel round shank, equipped with our innovative ME-clamping system. The ME-system provides force-fitted clamping along with higher precision and stability. Four different types of through coolant supply can be realized as required.

Anzugsmoment (Schraube) // Tightening torque (screw)

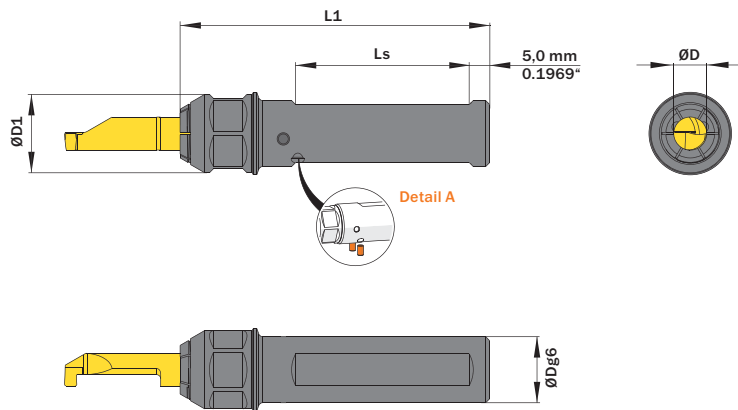
15,0 Nm - 25,0 Nm

Bitte Hinweise im Anhang beachten // Please read add. notes

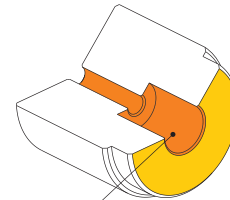
MASTER (S./P. 137), T02 (Seite/Page 138)



Scan QR-Code Oder besuchen Sie // Or Visit www.simtek.info/cp/1194



Entdecken Sie unseren simturn AX Halter „ME“. Discover our simturn AX toolholder „ME“.



- Hauptsächlich geeignet für diese Flächen
Mainly designed for these surfaces
- Je nach Schneidplatte ebenfalls möglich
Also possible depending on insert type

Abbildung zeigt / Drawing shows: A08.0016.ME ST T

ØD	ØDg6	Artikelnummer Part number	Webcode www.simtek.com/webcode	ØD1	L1	Ls	Standard Mutter Standard screw nut	Connectcode www.simtek.com/code
mm	mm			mm	mm	mm		

◀ Fortgesetzte Tabelle Continued Table Verwandte Werkzeuge finden Sie auch auf der vorhergehenden Seite! Related items can be found on the previous page as well!

8,0	15,875	A08.0.625.ME ST T	A012	19,0	75,0	42,0	A00.K.19.15.138	A08 A08T	Inch
8,0	16,0	A08.0016.ME ST T	AY67	19,0	75,0	42,0	A00.K.19.15.138	A08 A08T	
8,0	19,05	A08.0.750.ME ST T	A013	19,0	110,0	75,0	A00.K.19.15.138	A08 A08T	Inch
8,0	20,0	A08.0020.ME ST T	AY7U	19,0	90,0	55,0	A00.K.19.15.138	A08 A08T	
8,0	25,0	A08.0025.ME ST T	AY7V	19,0	110,0	75,0	A00.K.19.15.138	A08 A08T	
8,0	25,4	A08.1.000.ME ST T	A014	19,0	110,0	75,0	A00.K.19.15.138	A08 A08T	Inch

Verwandte Werkzeuge finden Sie auch auf der folgenden Seite! Related items can be found on the following page as well!

Fortgesetzte Tabelle Continued Table ▶

Bestellbeispiel // Order example: **A08.0016.ME ST T**

Detail A | 1 Halter - 4 Kühlmittelzufuhrarten // 1 Toolholder - 4 types of coolant supply



Klemmhalter, Innenbearbeitung, Rundschaft, „ME“

Rundschaft aus Stahl, mit unserem innovativen ME-Spannprinzip. Das ME-Spannsystem bietet kraftschlüssiges Spannen und dadurch optimale Präzision und Stabilität. Vier Kühlmittelzufuhrarten je nach Bedarf einstellbar.

Toolholder, Internal Applications, Round Shank „ME“

Steel round shank, equipped with our innovative ME-clamping system. The ME-system provides force-fitted clamping along with higher precision and stability. Four different types of through coolant supply can be realized as required.

Anzugsmoment (Schraube) // Tightening torque (screw)

15,0 Nm - 25,0 Nm

Bitte Hinweise im Anhang beachten // Please read add. notes

MASTER (Seite/Page 137), T02 (Seite/Page 138)



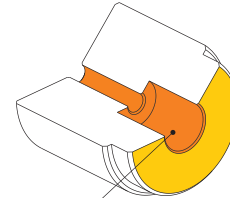
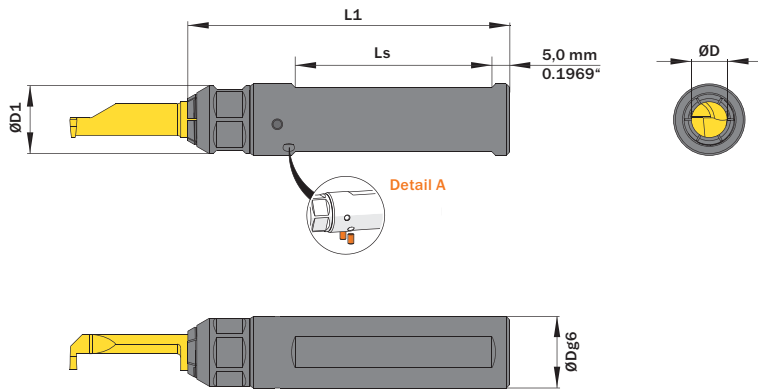
Legende Legend **139**

Scan QR-Code

Oder besuchen Sie // Or Visit www.simtek.info/cp/1193



Entdecken Sie unseren simturn AX Halter „ME“. Discover our simturn AX toolholder „ME“.



- Hauptsächlich geeignet für diese Flächen**
Mainly designed for these surfaces
- Je nach Schneidplatte ebenfalls möglich**
Also possible depending on insert type

Abbildung zeigt / Drawing shows: A10.0020.ME ST T

ØD	ØDg6	Artikelnummer Part number	Webcode www.simtek.com/webcode	ØD1	L1	Ls	Standard Mutter Standard screw nut	Connectcode www.simtek.com/code
mm	mm			mm	mm	mm		

Fortgesetzte Tabelle
Continued Table

Verwandte Werkzeuge finden Sie auch auf der vorhergehenden Seite!
Related items can be found on the previous page as well!

10,0	19,05	A10.0.750.ME ST T	AZUE	19,0	110,0	75,0	A00.K.19.15.138	A10L A10R A10T	Inch
10,0	20,0	A10.0020.ME ST T	AY7W	19,0	90,0	55,0	A00.K.19.15.138	A10L A10R A10T	
10,0	25,0	A10.0025.ME ST T	AY7X	19,0	110,0	75,0	A00.K.19.15.138	A10L A10R A10T	
10,0	25,4	A10.1.000.ME ST T	A015	19,0	110,0	75,0	A00.K.19.15.138	A10L A10R A10T	Inch

Bestellbeispiel // Order example: **A10.0020.ME ST T**

Detail A | 1 Halter - 4 Kühlmittelzufuhrarten // 1 Toolholder - 4 types of coolant supply



Klemmhalter, Innenbearbeitung, Rundschaft, „ME“

Rundschaft aus Stahl, mit unserem innovativen ME-Spannprinzip. Das ME-Spannsystem bietet kraftschlüssiges Spannen und dadurch optimale Präzision und Stabilität. Vier Kühlmittelzufuhrarten je nach Bedarf einstellbar.

Toolholder, Internal Applications, Round Shank „ME“

Steel round shank, equipped with our innovative ME-clamping system. The ME-system provides force-fitted clamping along with higher precision and stability. Four different types of through coolant supply can be realized as required.

Anzugsmoment (Schraube) // Tightening torque (screw)

15,0 Nm - 25,0 Nm

Bitte Hinweise im Anhang beachten // Please read add. notes

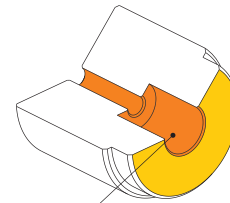
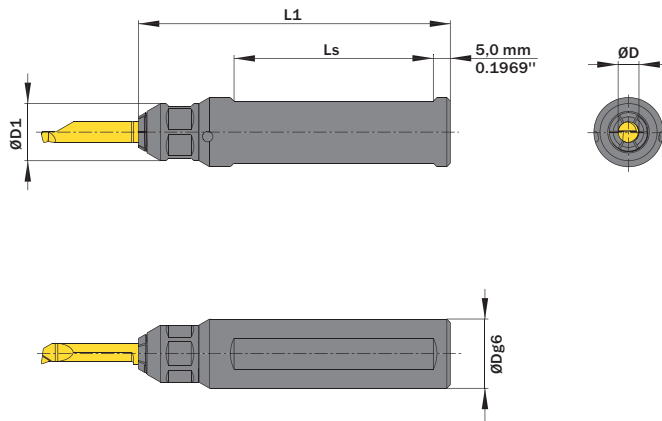
MASTER (Seite/Page 137), T02 (Seite/Page 138)



Scan QR-Code Oder besuchen Sie // Or Visit www.simtek.info/cp/1276



Entdecken Sie unseren simturn AX Halter „ME“. Discover our simturn AX toolholder „ME“.



- Hauptsächlich geeignet für diese Flächen
Mainly designed for these Surfaces
- Je nach Schneidplatte ebenfalls möglich
Also possible depending on insert type

ØD	ØDg6	Artikelnummer Part number	Webcode www.simtek.com/webcode	ØD1	L1	Ls	Standard Mutter Standard screw nut	Connectcode www.simtek.com/code
mm	mm			mm	mm	mm		
8,0	15,875	A08.0.625.ME IC	A10N	19,0	75,0	42,0	A00.K.19.15.138	A08T Inch
8,0	16,0	A08.0016.ME IC	A10Q	19,0	75,0	42,0	A00.K.19.15.138	A08T
8,0	19,05	A08.0.750.ME IC	A10P	19,0	110,0	75,0	A00.K.19.15.138	A08T Inch
8,0	20,0	A08.0020.ME IC	A10S	19,0	110,0	75,0	A00.K.19.15.138	A08T
8,0	22,0	A08.0022.ME IC	A2TF	19,0	110,0	75,0	A00.K.19.15.138	A08T
8,0	25,0	A08.0025.ME IC	A10T	19,0	110,0	75,0	A00.K.19.15.138	A08T
8,0	25,4	A08.1.000.ME IC	A10U	19,0	110,0	75,0	A00.K.19.15.138	A08T Inch

Bestellbeispiel // Order example: **A08.0016.ME IC**

- Für Individual-Schneidwerkzeuge auch ab A04 erhältlich.
- For customized cutting tools also available as of size A04.

Klemmhalter, Innenbearbeitung

SIMTEK Trägerwerkzeug mit Polygonschaft aus Stahl nach ISO 26623 mit unserem innovativen ME-Spannprinzip. Das ME-Spannprinzip bietet kraftschlüssiges Spannen und dadurch optimale Präzision und Stabilität. Vier Kühlmittelzufuhrarten je nach Bedarf einstellbar.

Toolholder, Internal Applications

SIMTEK toolholder with polygon shank according to ISO 26623 with our innovative ME-clamping-system. The ME-system provides force-fitted clamping along with higher precision and stability. Four different types of through coolant supply can be realized as required.

Anzugsmoment (Schraube) // Tightening torque (screw)

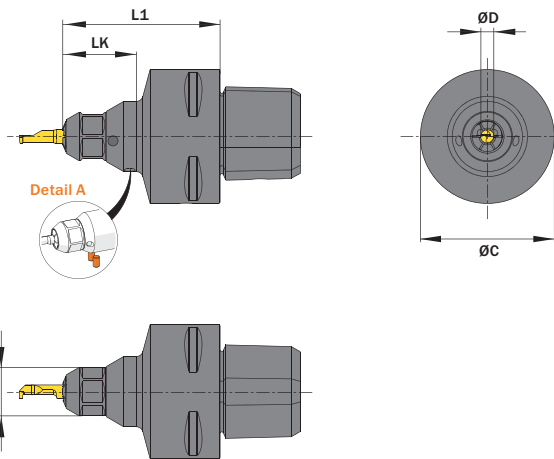
15,0 Nm - 25,0 Nm

Bitte Hinweise im Anhang beachten // Please read add. notes

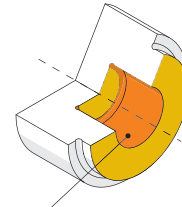
MASTER (Seite/Page 137), T02 (Seite/Page 138)

Scan QR-Code Oder besuchen Sie // Or Visit www.simtek.info/cp/1199

Legende Legend **139**



Entdecken Sie unseren neuen simturn AX Halter „ME“. Discover our new simturn AX toolholder „ME“.



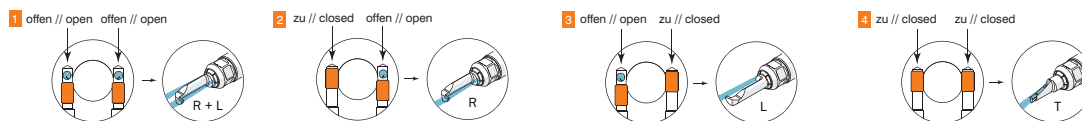
- Hauptsächlich geeignet für diese Flächen
Mainly designed for these surfaces
- Je nach Schneidplatte ebenfalls möglich
Also possible depending on insert type

Abbildung zeigt / Drawing shows: A04.00C4.05.ME T

Polygonschaftgröße Polygon shank size	ØD	Artikelnummer Part number	Webcode www.simtek.com/webcode	ØD1	ØC	L1	LK	Standard Mütter Standard screw nut	Connectcode www.simtek.com/ccode	
	mm									
▼ ØD = 4,0 mm										
C3	4,0	A04.00C3.00.ME T	A2PJ	14,5	40,0	67,0	30,0	A00.K.14.12.88	A04.L A04.R A04C.L	upd
C4	4,0	A04.00C4.00.ME T	AZFD	14,5	40,0	47,0	22,0	A00.K.14.12.88	A04C.R A04T	upd
▼ ØD = 5,0 mm										
C3	5,0	A05.00C3.00.ME T	A2GØ	14,5	40,0	67,0	30,0	A00.K.14.12.88	A05.L A05.R A05T	upd
C4	5,0	A05.00C4.00.ME T	AZUW	14,5	40,0	47,0	23,5	A00.K.14.12.88	A05.L A05.R A05T	upd
▼ ØD = 6,0 mm										
C3	6,0	A06.00C3.00.ME T	A1QY	16,5	40,0	67,0	30,0	A00.K.16.12.108	A05.L A06.R A06T	upd
C4	6,0	A06.00C4.00.ME T	A45B	14,5	40,0	47,0	30,0	A00.K.16.12.108	A06.L A06.R A06T	new

Bestellbeispiel // Order example: **A04.00C4.00.ME T**

Detail A | 1 Halter - 4 Kühlmittelzufuhrarten // 1 Toolholder - 4 types of coolant supply



Klemmhalter, Innenbearbeitung, VDI, „ME“

Klemmhalter VDI-Aufnahme, mit unserem innovativen ME-Spannprinzip. Das ME-Spannsystem bietet kraftschlüssiges Spannen und dadurch optimale Präzision und Stabilität. Vier Kühlmittelzufuhrarten je nach Bedarf einstellbar.

Toolholder, Internal Applications, VDI, „ME“

Toolholder with VDI-Fixation, equipped with our innovative ME-clamping system. The ME-system provides force-fitted clamping along with higher precision and stability. Four different types of through coolant supply can be realized as required.

Anzugsmoment (Schraube) // Tightening torque (screw)

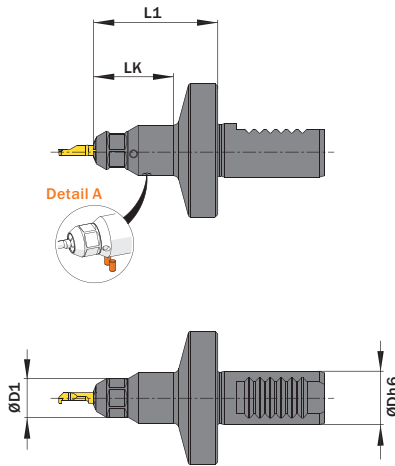
15,0 Nm - 25,0 Nm

Bitte Hinweise im Anhang beachten // Please read add. notes

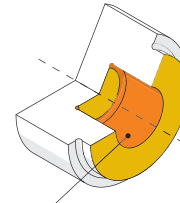
MASTER (Seite/Page 137), T02 (Seite/Page 138)

Scan QR-Code Oder besuchen Sie // Or Visit www.simtek.info/cp/1224

Legende Legend **139**



Entdecken Sie unseren neuen simturn AX Halter „ME“. Discover our new simturn AX toolholder „ME“.



- Hauptsächlich geeignet für diese Flächen
Mainly designed for these surfaces
- Je nach Schneidplatte ebenfalls möglich
Also possible depending on insert type

ØD	ØDh6	Artikelnummer Part number	Webcode www.simtek.com/webcode	ØD1	L1	LK	Standard Mutter Standard screw nut	Connectcode www.simtek.com/code
mm	mm			mm	mm	mm		
▼ ØDh6 = 16,0 mm								
4,0	16,0	A04.VD16.ME T	AZV2	14,5	41,5	30,0	A00.K.14.12.88	A04.L A04.R A04.C.L A04.C.R A04.T
5,0	16,0	A05.VD16.ME T	AZV9	14,5	41,5	30,0	A00.K.14.12.88	A05.L A05.R A05.T
6,0	16,0	A06.VD16.ME T	AZWG	16,5	41,5	30,0	A00.K.16.12.108	A06.L A06.R A06.T
▼ ØDh6 = 20,0 mm								
4,0	20,0	A04.VD20.ME T	AZV4	14,5	46,5	30,0	A00.K.14.12.88	A04.L A04.R A04.C.L A04.C.R A04.T
5,0	20,0	A05.VD20.ME T	AZWA	14,5	46,5	30,0	A00.K.14.12.88	A05.L A05.R A05.T
6,0	20,0	A06.VD20.ME T	AZWJ	16,5	46,5	30,0	A00.K.16.12.108	A06.L A06.R A06.T
▼ ØDh6 = 25,0 mm								
4,0	25,0	A04.VD25.ME T	AF3W	14,5	52,0	30,0	A00.K.14.12.88	A04.L A04.R A04.C.L A04.C.R A04.T
5,0	25,0	A05.VD25.ME T	AZWC	14,5	52,0	30,0	A00.K.14.12.88	A05.L A05.R A05.T
6,0	25,0	A06.VD25.ME T	AJYQ	16,5	52,0	30,0	A00.K.16.12.108	A06.L A06.R A06.T
▼ ØDh6 = 30,0 mm								
4,0	30,0	A04.VD30.ME T	AATY	14,5	52,0	30,0	A00.K.14.12.88	A04.L A04.R A04.C.L A04.C.R A04.T
5,0	30,0	A05.VD30.ME T	AZWE	14,5	52,0	30,0	A00.K.14.12.88	A05.L A05.R A05.T
6,0	30,0	A06.VD30.ME T	AZWN	16,5	52,0	30,0	A00.K.16.12.108	A06.L A06.R A06.T

Verwandte Werkzeuge finden Sie auch auf der folgenden Seite!
Related Items can be found on the following page as well!

Fortgesetzte Tabelle
Continued Table

Bestellbeispiel // Order example: **A04.VD20.ME T**

Detail A | 1 Halter - 4 Kühlmittelzufuhrarten // 1 Toolholder - 4 types of coolant supply



Klemmhalter, Innenbearbeitung, VDI, „ME“

Klemmhalter VDI-Aufnahme, mit unserem innovativen ME-Spannprinzip. Das ME-Spannsystem bietet kraftschlüssiges Spannen und dadurch optimale Präzision und Stabilität. Vier Kühlmittelzufuhrarten je nach Bedarf einstellbar.

Toolholder, Internal Applications, VDI, „ME“

Toolholder with VDI-Fixation, equipped with our innovative ME-clamping system. The ME-system provides force-fitted clamping along with higher precision and stability. Four different types of through coolant supply can be realized as required.

Anzugsmoment (Schraube) // Tightening torque (screw)

15,0 Nm - 25,0 Nm

Bitte Hinweise im Anhang beachten // Please read add. notes

MASTER (Seite/Page 137), T02 (Seite/Page 138)



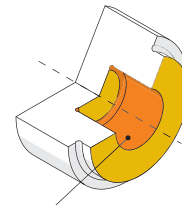
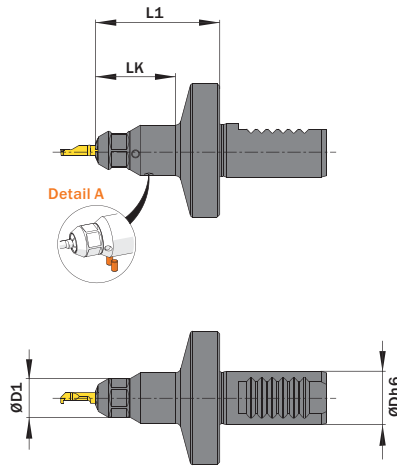
Legende Legend **139**

Scan QR-Code

Oder besuchen Sie // Or Visit www.simtek.info/cp/1225



Entdecken Sie unseren neuen simturn AX Halter „ME“. Discover our new simturn AX toolholder „ME“.



- Hauptsächlich geeignet für diese Flächen
Mainly designed for these surfaces
- Je nach Schneidplatte ebenfalls möglich
Also possible depending on insert type

ØD	ØDh6	Artikelnummer Part number	Webcode www.simtek.com/webcode	ØD1	L1	LK	Standard Mutter Standard screw nut	Connectcode www.simtek.com/code
mm	mm			mm	mm	mm		

Fortgesetzte Tabelle Continued Table **Verwandte Werkzeuge finden Sie auch auf der vorhergehenden Seite!**
Related items can be found on the previous page as well!

▼ ØDh6 = 16,0 mm								
7,0	16,0	A07.VD16.ME T	AZWQ	16,5	41,5	30,0	A00.K.16.12.108	A07.L A07.R A07.T
8,0	16,0	A08.VD16.ME T	AZWZ	19,0	41,5	30,0	A00.K.19.15.138	A08 A08T
10,0	16,0	A10.VD16.ME T	AZW6	19,0	41,5	30,0	A00.K.19.15.138	A10.L A10.R A10T
▼ ØDh6 = 20,0 mm								
7,0	20,0	A07.VD20.ME T	AZWT	16,5	46,5	30,0	A00.K.16.12.108	A07.L A07.R A07.T
8,0	20,0	A08.VD20.ME T	AZW1	19,0	46,5	30,0	A00.K.19.15.138	A08 A08T
10,0	20,0	A10.VD20.ME T	AC43	19,0	46,5	30,0	A00.K.19.15.138	A10.L A10.R A10T
▼ ØDh6 = 25,0 mm								
7,0	25,0	A07.VD25.ME T	AZWV	16,5	52,0	30,0	A00.K.16.12.108	A07.L A07.R A07.T
8,0	25,0	A08.VD25.ME T	AD86	19,0	52,0	30,0	A00.K.19.15.138	A08 A08T
10,0	25,0	A10.VD25.ME T	ACSB	19,0	52,0	30,0	A00.K.19.15.138	A10.L A10.R A10T
▼ ØDh6 = 30,0 mm								
7,0	30,0	A07.VD30.ME T	AZWX	16,5	52,0	30,0	A00.K.16.12.108	A07.L A07.R A07.T
8,0	30,0	A08.VD30.ME T	AZW3	19,0	52,0	30,0	A00.K.19.15.138	A08 A08T
10,0	30,0	A10.VD30.ME T	AZXA	19,0	52,0	30,0	A00.K.19.15.138	A10.L A10.R A10T

Bestellbeispiel // Order example: **A07.VD20.ME T**

Detail A | 1 Halter - 4 Kühlmittelzufuhrarten // 1 Toolholder - 4 types of coolant supply



Klemmhalter, Innenbearbeitung, VDI, „ME“, über Kopf

Klemmhalter VDI-Aufnahme, mit unserem innovativen ME-Spannprinzip. Das ME-Spannsystem bietet kraftschlüssiges Spannen und dadurch optimale Präzision und Stabilität.

Toolholder, Internal Applications, VDI, „ME“, Upside down

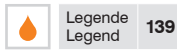
Toolholder with VDI-Fixation, equipped with our innovative ME-clamping system. The ME-system provides force-fitted clamping along with higher precision and stability.

Anzugsmoment (Schraube) // Tightening torque (screw)

15,0 Nm - 25,0 Nm

Bitte Hinweise im Anhang beachten // Please read add. notes

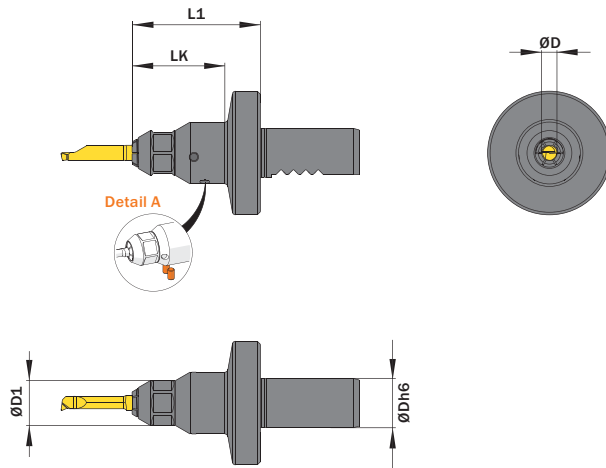
MASTER (Seite/Page 137), T02 (Seite/Page 138)



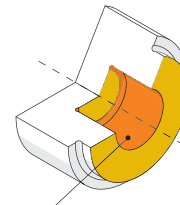
Legende Legend **139**

Scan QR-Code

Oder besuchen Sie // Or Visit www.simtek.info/cp/1235



Entdecken Sie unseren neuen simturn AX Halter „ME“. Discover our new simturn AX toolholder „ME“.



- Hauptsächlich geeignet für diese Flächen
Mainly designed for these surfaces
- Je nach Schneidplatte ebenfalls möglich
Also possible depending on insert type

ØD	ØDh6	Artikelnummer Part number	Webcode www.simtek.com/webcode	ØD1	L1	LK	Standard Mutter Standard screw nut	Connectcode www.simtek.com/ccode
mm	mm			mm	mm	mm		
▼ Standard Mutter // Standard screw nut = A00.K.14.12.88								
4,0	16,0	A04.VD16.B.ME T	AZV3	14,5	41,5	30,0	A00.K.14.12.88	A04.R A04C.R A04T
4,0	20,0	A04.VD20.B.ME T	AZV5	14,5	46,5	30,0	A00.K.14.12.88	A04.R A04C.R A04T
4,0	25,0	A04.VD25.B.ME T	AZV6	14,5	52,0	30,0	A00.K.14.12.88	A04.R A04C.R A04T
4,0	30,0	A04.VD30.B.ME T	AZV7	14,5	52,0	30,0	A00.K.14.12.88	A04.R A04C.R A04T
5,0	16,0	A05.VD16.B.ME T	AZUX	14,5	41,5	30,0	A00.K.14.12.88	A05.R A05T
5,0	20,0	A05.VD20.B.ME T	AZWB	14,5	46,5	30,0	A00.K.14.12.88	A05.R A05T
5,0	25,0	A05.VD25.B.ME T	AZWD	14,5	52,0	30,0	A00.K.14.12.88	A05.R A05T
5,0	30,0	A05.VD30.B.ME T	AZWF	14,5	52,0	30,0	A00.K.14.12.88	A05.R A05T
▼ Standard Mutter // Standard screw nut = A00.K.16.12.108								
6,0	16,0	A06.VD16.B.ME T	AZWH	16,5	41,5	30,0	A00.K.16.12.108	A06.R A06T
6,0	20,0	A06.VD20.B.ME T	AZWK	16,5	46,5	30,0	A00.K.16.12.108	A06.R A06T
6,0	25,0	A06.VD25.B.ME T	AZWM	16,5	52,0	30,0	A00.K.16.12.108	A06.R A06T
6,0	30,0	A06.VD30.B.ME T	AZWP	16,5	52,0	30,0	A00.K.16.12.108	A06.R A06T

Verwandte Werkzeuge finden Sie auch auf der folgenden Seite!
Related Items can be found on the following page as well!

Fortgesetzte Tabelle
Continued Table

Bestellbeispiel // Order example: **A04.VD20.B.ME T**

Detail A | 1 Halter – 4 Kühlmittelzufuhrarten // 1 Toolholder – 4 types of coolant supply



Kleinteilebearbeitung // Small Part Machining

simturn AX > Trägerwerkzeug // Toolholder

Klemmhalter, Innenbearbeitung, VDI, „ME“, über Kopf

Klemmhalter VDI-Aufnahme, mit unserem innovativen ME-Spannprinzip. Das ME-Spannsystem bietet kraftschlüssiges Spannen und dadurch optimale Präzision und Stabilität. Vier Kühlmittelzufuhrarten je nach Bedarf einstellbar.

Toolholder, Internal Applications, VDI, „ME“, Upside Down

Toolholder with VDI-Fixation, equipped with our innovative ME-clamping system. The ME-system provides force-fitted clamping along with higher precision and stability. Four different types of through coolant supply can be realized as required.



Anzugsmoment (Schraube) // Tightening torque (screw)

15,0 Nm - 25,0 Nm

Bitte Hinweise im Anhang beachten // Please read add. notes

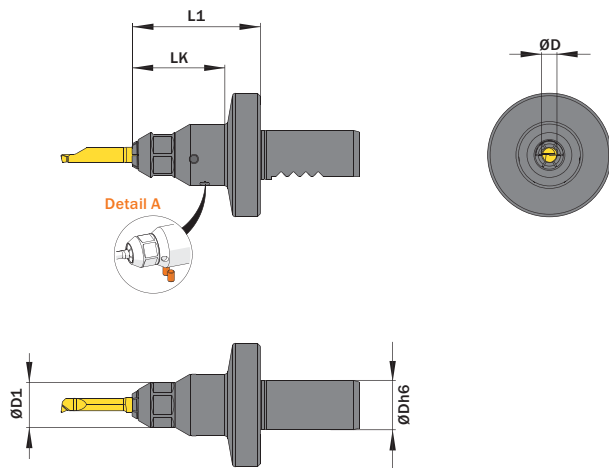
MASTER (Seite/Page 137), T02 (Seite/Page 138)



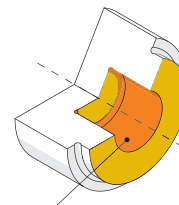
Legende Legend **139**



Oder besuchen Sie // Or Visit www.simtek.info/cp/1236



Entdecken Sie unseren neuen simturn AX Halter „ME“. Discover our new simturn AX toolholder „ME“.



- Hauptsächlich geeignet für diese Flächen
Mainly designed for these surfaces
- Je nach Schneidplatte ebenfalls möglich
Also possible depending on insert type

ØD	ØDh6	Artikelnummer Part number	Webcode www.simtek.com/webcode	ØD1	L1	LK	Standard Mütter Standard screw nut	Connectcode www.simtek.com/code
mm	mm			mm	mm	mm		

Fortgesetzte Tabelle Continued Table

Verwandte Werkzeuge finden Sie auch auf der vorhergehenden Seite!
Related items can be found on the previous page as well!

▼ ØDh6 = 16,0 mm								
7,0	16,0	A07.VD16.B.ME T	AZWS	16,5	41,5	30,0	A00.K.16.12.108	A07.R A07T
8,0	16,0	A08.VD16.B.ME T	AZW0	19,0	41,5	30,0	A00.K.19.15.138	A08 A08T
10,0	16,0	A10.VD16.B.ME T	AZW7	19,0	41,5	30,0	A00.K.19.15.138	A10.R A10T
▼ ØDh6 = 20,0 mm								
7,0	20,0	A07.VD20.B.ME T	AZWU	16,5	46,5	30,0	A00.K.16.12.108	A07.R A07T
8,0	20,0	A08.VD20.B.ME T	AZW2	19,0	46,5	30,0	A00.K.19.15.138	A08 A08T
10,0	20,0	A10.VD20.B.ME T	AZW8	19,0	46,5	30,0	A00.K.19.15.138	A10.R A10T
▼ ØDh6 = 25,0 mm								
7,0	25,0	A07.VD25.B.ME T	AZWW	16,5	52,0	30,0	A00.K.16.12.108	A07.R A07T
8,0	25,0	A08.VD25.B.ME T	AZW4	19,0	52,0	30,0	A00.K.19.15.138	A08 A08T
10,0	25,0	A10.VD25.B.ME T	AZW9	19,0	52,0	30,0	A00.K.19.15.138	A10.R A10T
▼ ØDh6 = 30,0 mm								
7,0	30,0	A07.VD30.B.ME T	AZWY	16,5	52,0	30,0	A00.K.16.12.108	A07.R A07T
8,0	30,0	A08.VD30.B.ME T	AZW5	19,0	52,0	30,0	A00.K.19.15.138	A08 A08T
10,0	30,0	A10.VD30.B.ME T	AZX8	19,0	52,0	30,0	A00.K.19.15.138	A10.R A10T

Bestellbeispiel // Order example: **A07.VD20.B.ME T**

Detail A | 1 Halter – 4 Kühlmittelzufuhrarten // 1 Toolholder – 4 types of coolant supply



Kleinteilebearbeitung // Small Part Machining

simturn AX > Trägerwerkzeug // Toolholder

Höhenverstellbare Kassette, für Rückseitenbearbeitungen, „ME“

Kassette für höhenverstellbare Rückseitenbearbeitung auf Grundhaltern-Typ TOG der Marke precium, mit unserem innovativen ME-Spannprinzip. Das ME-Spannsystem bietet kraftschlüssiges Spannen und dadurch optimale Präzision und Stabilität. Vier Kühlmittelzufuhrarten je nach Bedarf einstellbar.

Height-Adjustable Cassette for back operations, „ME“

Cassette for height-adjustable back operations tools. Compatible to TOG-System by precium, equipped with our innovative ME-clamping system. The ME-system provides force-fitted clamping along with higher precision and stability. Four different types of through coolant supply can be realized as required.



Anzugsmoment (Schraube) // Tightening torque (screw)

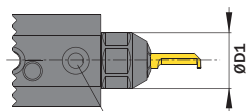
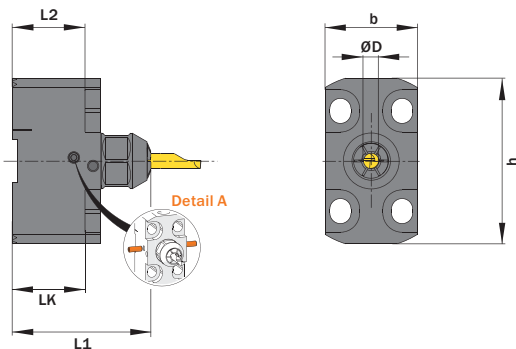
15,0 Nm - 25,0 Nm

Bitte Hinweise im Anhang beachten // Please read add. notes

MASTER (Seite/Page 137), T02 (Seite/Page 138)

Legende Legend **139**

Scan QR-Code Oder besuchen Sie // Or Visit www.simtek.info/cp/1221



Kühlmittelanschluss // Coolant supply

Abbildung zeigt / Drawing shows: TOG.K.A04.A1.ME T



Entdecken Sie unseren neuen simturn AX Halter „ME“. Discover our new simturn AX toolholder „ME“.

Mehr Informationen unter www.precium.de
More information on www.precium.de



Abbildung ähnlich // Illustration only

ØD	Artikelnummer Part number	Webcode www.simtek.com/webcode	b	ØD1	h	L1	L2	LK	Standard Mutter Standard screw nut	Connectcode www.simtek.com/ccode
mm			mm	mm	mm	mm	mm	mm		
4,0	TOG.K.A04.A1.ME T	AZMX	24,0	14,5	43,0	36,0	18,9	18,9	A00.K.14.12.88	A04.R A04C.R A04T
5,0	TOG.K.A05.A1.ME T	AZMY	24,0	14,5	43,0	39,5	18,9	18,9	A00.K.14.12.88	A05.R A05T
6,0	TOG.K.A06.A1.ME T	AZMZ	24,0	16,5	43,0	39,5	18,9	18,9	A00.K.16.12.108	A06.R A06T

Bestellbeispiel // Order example: **TOG.K.A04.A1.ME T**

Detail A | 1 Halter - 4 Kühlmittelzufuhrarten // 1 Toolholder - 4 types of coolant supply



simturn AX

simturn DX

simturn PX

simturn H2

simturn K2

simturn C4

simturn GX

simturn E3

simturn E12

simturn FX

simturn Decolletage

simturn OA

Index

Klemmhalter, Innenbearbeitung, Quadratschaft

90 Grad gekröpfte Ausführung.

Toolholder, Internal Applications, Square Shank

90 degree cranked style.

Anzugsmoment (Schraube) // Tightening torque (screw)

7,0 Nm

Bitte Hinweise im Anhang beachten // Please read add. notes

MASTER (Seite/Page 137)

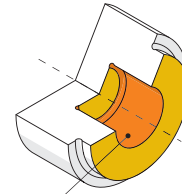
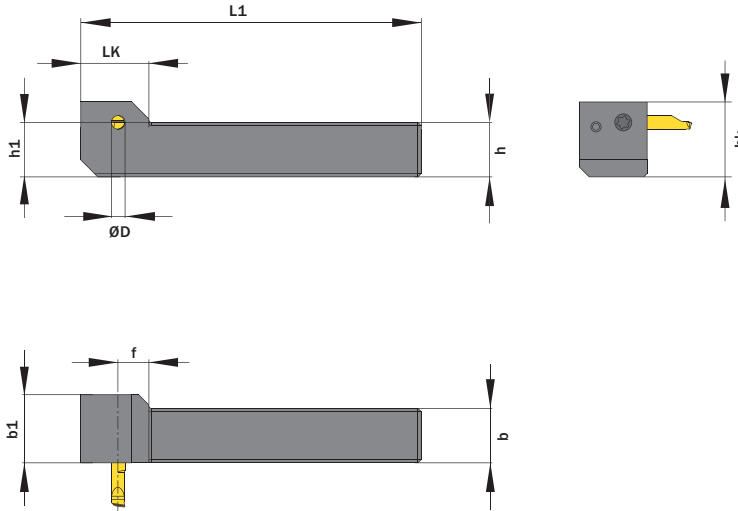


Legende
Legend **139**



Scan
QR-Code

Oder besuchen Sie // Or Visit
www.simtek.info/cp/1026



- Hauptsächlich geeignet für diese Flächen
Mainly designed for these surfaces
- Je nach Schneidplatte ebenfalls möglich
Also possible depending on insert type

Abbildung zeigt / Drawing shows: A04.1616.G.100 R

ØD	h	b	L1	Artikelnummer Part number	Webcode www.simtek.com/webcode	b1	f	hk	h1	LK	Schraube Screw	Schraubenschlüssel Screw driver	Connectcode www.simtek.com/code
mm	mm	mm	mm			mm	mm	mm	mm	mm			
▼ ØD = 4,0 mm													
4,0	12,0	12,0	80,0	A04.1212.G.080 R/L	R AW2V L AW2U	20,0	9,0	18,0	12,0	20,0	A M6x7,5 T15F	T15F	R A04.R A04C.R L A04.L A04C.L
4,0	16,0	16,0	100,0	A04.1616.G.100 R/L	R AW4E L AW2W	20,0	9,0	22,0	16,0	20,0	A M6x7,5 T15F	T15F	R A04.R A04C.R L A04.L A04C.L
▼ ØD = 5,0 mm													
5,0	12,7	12,7	80,0	A05.0.500.G.080 R	A5AV	25,0	9,0	18,0	12,7	20,0	A M6x7,5 T15F	T15F	A05.R
5,0	15,875	15,875	100,0	A05.0.625.G.100 R	A5AX	25,0	9,0	22,0	15,9	20,0	A M6x7,5 T15F	T15F	A05.R
5,0	12,0	12,0	80,0	A05.1212.G.080 R/L	R AW2Y L AW2X	25,0	9,0	18,0	12,0	20,0	A M6x7,5 T15F	T15F	R A05.R L A05.L
5,0	16,0	16,0	100,0	A05.1616.G.100 R/L	R AW2Ø L AW2Z	25,0	9,0	22,0	16,0	20,0	A M6x7,5 T15F	T15F	R A05.R L A05.L
▼ ØD = 6,0 mm													
6,0	12,0	12,0	80,0	A06.1212.G.080 R/L	R AW22 L AW21	25,0	9,0	18,0	12,0	20,0	A M6x7,5 T15F	T15F	R A06.R L A06.L
6,0	16,0	16,0	100,0	A06.1616.G.100 R/L	R AW24 L AW23	25,0	9,0	22,0	16,0	20,0	A M6x7,5 T15F	T15F	R A06.R L A06.L
▼ ØD = 7,0 mm													
7,0	12,0	12,0	80,0	A07.1212.G.080 R/L	R AW26 L AW25	25,0	9,0	18,0	12,0	20,0	A M6x7,5 T15F	T15F	R A07.R L A07.L
7,0	16,0	16,0	100,0	A07.1616.G.100 R/L	R AW28 L AW27	25,0	9,0	22,0	16,0	20,0	A M6x7,5 T15F	T15F	R A07.R L A07.L

Bestellbeispiel // Order example: **A04.1616.G.100 R** (R = Rechte Ausführung // Right hand version)

Klemmhalter, Innenbearbeitung, Quadratschaft

Quadratischer Schaft für die Innenbearbeitung.

Toolholder, Internal Applications, Square Shank

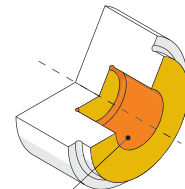
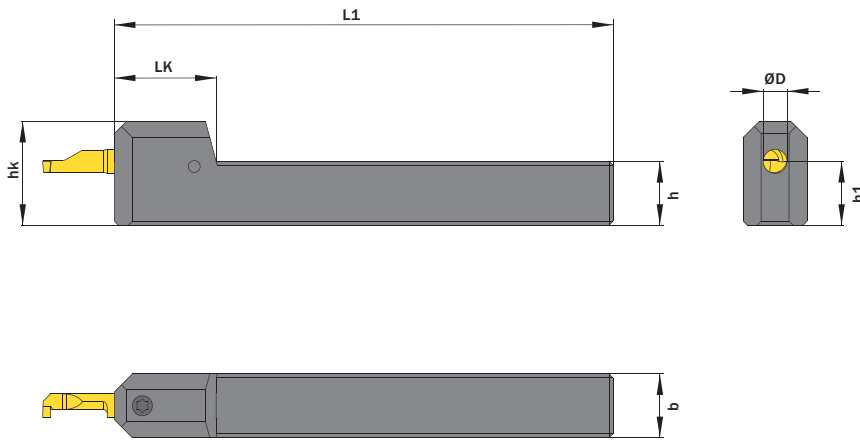
Square shank for internal applications.

Anzugsmoment (Schraube) // Tightening torque (screw)
7,0 Nm

Bitte Hinweise im Anhang beachten // Please read add. notes
MASTER (Seite/Page 137)

TW Legende
ST Legend **139**

Scan QR-Code Oder besuchen Sie // Or Visit www.simtek.info/cp/745



- Hauptsächlich geeignet für diese Flächen
Mainly designed for these surfaces
- Je nach Schneidplatte ebenfalls möglich
Also possible depending on insert type

Abbildung zeigt / Drawing shows: A06.1616

ØD	h	b	Artikelnummer Part number	Webcode www.simtek.com/webcode	h1	hk	L1	LK	Schraube Screw	Schraubenschlüssel Screw driver	Connectcode www.simtek.com/code	
mm	mm	mm			mm	mm	mm	mm				
▼ ØD = 4,0 mm												
4,0	12,7	12,7	A04.0.500.S	AJ10	12,7	22,0	100,0	19,0	A M6x7,5 T15F	T15F	A04.L A04.R A04CL A04CR	inch
4,0	15,875	15,875	A04.0.625.S	ACQ9	15,88	25,0	125,0	19,0	A M6x7,5 T15F	T15F	A04.L A04.R A04CL A04CR	inch
4,0	19,05	19,05	A04.0.750.S	AHP1	19,05	28,0	125,0	19,0	A M6x7,5 T15F	T15F	A04.L A04.R A04CL A04CR	inch
4,0	25,4	25,4	A04.1.000.S	AT9S	25,4	34,0	150,0	19,0	A M6x7,5 T15F	T15F	A04.L A04.R A04CL A04CR	inch
4,0	10,0	10,0	A04.1010	ACXN	10,0	19,0	100,0	19,0	A M6x7,5 T15F	T15F	A04.L A04.R A04CL A04CR	
4,0	12,0	12,0	A04.1212	AF1Y	12,0	21,0	100,0	19,0	A M6x7,5 T15F	T15F	A04.L A04.R A04CL A04CR	
4,0	16,0	16,0	A04.1616	AC69	16,0	25,0	125,0	19,0	A M6x7,5 T15F	T15F	A04.L A04.R A04CL A04CR	
4,0	20,0	20,0	A04.2020	AD4F	20,0	29,0	125,0	19,0	A M6x7,5 T15F	T15F	A04.L A04.R A04CL A04CR	
4,0	25,0	25,0	A04.2525	ATZG	25,0	34,0	150,0	19,0	A M6x7,5 T15F	T15F	A04.L A04.R A04CL A04CR	
▼ ØD = 5,0 mm												
5,0	12,7	12,7	A05.0.500.S	AAPM	12,7	22,5	100,0	25,0	A M6x7,5 T15F	T15F	A05.L A05.R	inch
5,0	15,875	15,875	A05.0.625.S	ANNQ	15,88	25,5	125,0	25,0	A M6x7,5 T15F	T15F	A05.L A05.R	inch
5,0	19,05	19,05	A05.0.750.S	ANWK	19,05	28,5	125,0	25,0	A M6x7,5 T15F	T15F	A05.L A05.R	inch
5,0	25,4	25,4	A05.1.000.S	ATZP	25,4	34,5	150,0	25,0	A M6x7,5 T15F	T15F	A05.L A05.R	inch
5,0	10,0	10,0	A05.1010	AMKZ	10,0	19,5	100,0	25,0	A M6x7,5 T15F	T15F	A05.L A05.R	
5,0	12,0	12,0	A05.1212	ABNX	12,0	21,5	100,0	25,0	A M6x7,5 T15F	T15F	A05.L A05.R	
5,0	16,0	16,0	A05.1616	AJYG	16,0	25,5	125,0	25,0	A M6x7,5 T15F	T15F	A05.L A05.R	
5,0	20,0	20,0	A05.2020	AF6C	20,0	29,5	125,0	25,0	A M6x7,5 T15F	T15F	A05.L A05.R	
5,0	25,0	25,0	A05.2525	ATZH	25,0	34,5	150,0	25,0	A M6x7,5 T15F	T15F	A05.L A05.R	

Verwandte Werkzeuge finden Sie auch auf der folgenden Seite!
Related Items can be found on the following page as well!

Fortgesetzte Tabelle
Continued Table

Bestellbeispiel // Order example: **A05.2020**

Klemmhalter, Innenbearbeitung, Quadratschaft

Quadratischer Schaft für die Innenbearbeitung.

Toolholder, Internal Applications, Square Shank

Square shank for internal applications.

Anzugsmoment (Schraube) // Tightening torque (screw)

7,0 Nm

Bitte Hinweise im Anhang beachten // Please read add. notes

MASTER (Seite/Page 137)



TW
ST

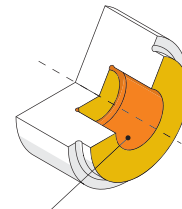
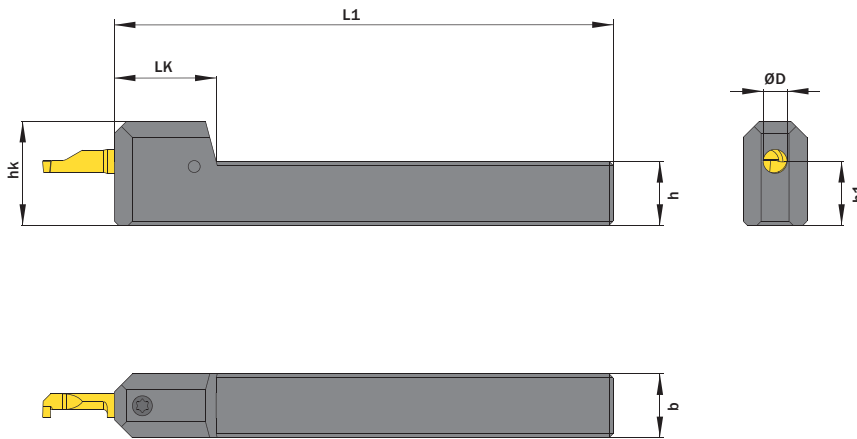
Legende
Legend

139



Scan
QR-Code

Oder besuchen Sie // Or Visit
www.simtek.info/cp/786



- Hauptsächlich geeignet für diese Flächen
Mainly designed for these surfaces
- Je nach Schneidplatte ebenfalls möglich
Also possible depending on insert type

Abbildung zeigt / Drawing shows: A06.1616

ØD	h	b	Artikelnummer Part number	Webcode www.simtek.com/webcode	h1	hk	L1	LK	Schraube Screw	Schraubenschlüssel Screw driver	Connectcode www.simtek.com/code
mm	mm	mm			mm	mm	mm	mm			

Fortgesetzte Tabelle
Continued Table

Verwandte Werkzeuge finden Sie auch auf der vorhergehenden Seite!
Related Items can be found on the previous page as well!

▼ ØD = 6,0 mm

6,0	12,7	12,7	A06.0.500.S	AD05	12,7	23,0	100,0	26,0	A M6x7,5 T15F	T15F	A06.L A06.R	Inch
6,0	15,875	15,875	A06.0.625.S	AJQH	15,88	26,0	125,0	25,5	A M6x7,5 T15F	T15F	A06.L A06.R	Inch
6,0	19,05	19,05	A06.0.750.S	AF15	19,05	29,0	125,0	25,5	A M6x7,5 T15F	T15F	A06.L A06.R	Inch
6,0	25,4	25,4	A06.1.000.S	ATZN	25,4	35,0	150,0	25,5	A M6x7,5 T15F	T15F	A06.L A06.R	Inch
6,0	12,0	12,0	A06.1212	AA3P	12,0	22,0	100,0	26,0	A M6x7,5 T15F	T15F	A06.L A06.R	
6,0	16,0	16,0	A06.1616	AKPT	16,0	26,0	125,0	25,5	A M6x7,5 T15F	T15F	A06.L A06.R	
6,0	20,0	20,0	A06.2020	ANFN	20,0	30,0	125,0	25,5	A M6x7,5 T15F	T15F	A06.L A06.R	
6,0	25,0	25,0	A06.2525	ATZJ	25,0	35,0	150,0	25,5	A M6x7,5 T15F	T15F	A06.L A06.R	

▼ ØD = 7,0 mm

7,0	15,875	15,875	A07.0.625.S	AC7G	15,88	26,5	125,0	26,5	A M6x7,5 T15F	T15F	A07.L A07.R	Inch
7,0	19,05	19,05	A07.0.750.S	AKF3	19,05	29,5	125,0	26,5	A M6x7,5 T15F	T15F	A07.L A07.R	Inch
7,0	25,4	25,4	A07.1.000.S	ATZM	25,4	35,5	150,0	26,5	A M6x7,5 T15F	T15F	A07.L A07.R	Inch
7,0	16,0	16,0	A07.1616	AFAZ	16,0	26,5	125,0	26,5	A M6x7,5 T15F	T15F	A07.L A07.R	
7,0	20,0	20,0	A07.2020	AF1G	20,0	30,5	125,0	26,5	A M6x7,5 T15F	T15F	A07.L A07.R	
7,0	25,0	25,0	A07.2525	ATZK	25,0	35,5	150,0	26,5	A M6x7,5 T15F	T15F	A07.L A07.R	

Verwandte Werkzeuge finden Sie auch auf der folgenden Seite!
Related Items can be found on the following page as well!

Fortgesetzte Tabelle
Continued Table

Bestellbeispiel // Order example: **A06.2020**

Klemmhalter, Innenbearbeitung, Quadratschaft

Quadratischer Schaft für die Innenbearbeitung.

Toolholder, Internal Applications, Square Shank

Square shank for internal applications.

Anzugsmoment (Schraube) // Tightening torque (screw)

7,0 Nm

Bitte Hinweise im Anhang beachten // Please read add. notes

MASTER (Seite/Page 137)

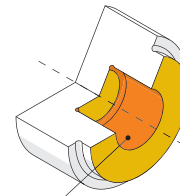
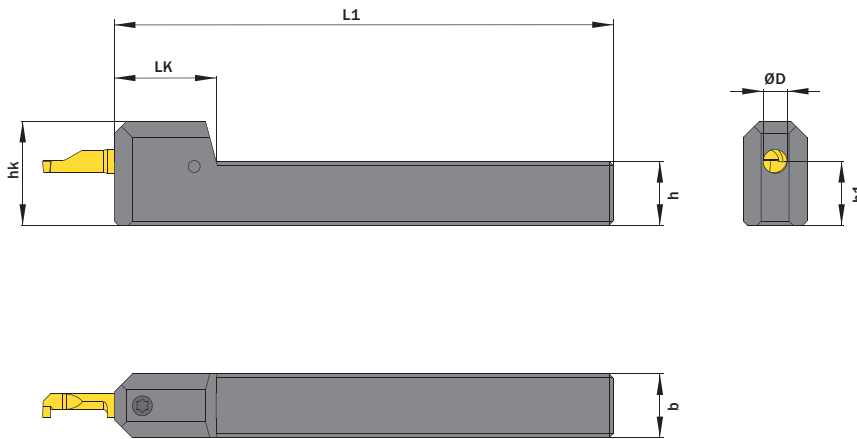


TW Legende
ST Legend

139

Scan QR-Code

Oder besuchen Sie // Or Visit
www.simtek.info/cp/1062



- Hauptsächlich geeignet für diese Flächen
Mainly designed for these surfaces
- Je nach Schneidplatte ebenfalls möglich
Also possible depending on insert type

Abbildung zeigt / Drawing shows: A06.1616

ØD	h	b	Artikelnummer Part number	Webcode www.simtek.com/webcode	h1	hk	L1	LK	Schraube Screw	Schraubenschlüssel Screw driver	Connectcode www.simtek.com/ccode
mm	mm	mm			mm	mm	mm	mm			

Fortgesetzte Tabelle
Continued Table

Verwandte Werkzeuge finden Sie auch auf der vorhergehenden Seite!
Related items can be found on the previous page as well!

▼ ØD = 8,0 mm												
8,0	15,875	15,875	A08.0.625.S	AFE2	15,88	27,0	125,0	32,5	A M6x7,5 T15F	T15F	A08 A08T	Inch
8,0	19,05	19,05	A08.0.750.S	AKVD	19,05	30,0	125,0	32,5	A M6x7,5 T15F	T15F	A08 A08T	Inch
8,0	25,4	25,4	A08.1.000.S	AT9T	25,4	36,0	150,0	32,5	A M6x7,5 T15F	T15F	A08 A08T	Inch
8,0	16,0	16,0	A08.1616	AGKM	16,0	27,0	125,0	32,5	A M6x7,5 T15F	T15F	A08 A08T	
8,0	20,0	20,0	A08.2020	ABBG	20,0	31,0	125,0	32,5	A M6x7,5 T15F	T15F	A08 A08T	
8,0	25,0	25,0	A08.2525	AT9P	25,0	36,0	150,0	32,5	A M6x7,5 T15F	T15F	A08 A08T	
▼ ØD = 10,0 mm												
10,0	19,05	19,05	A10.0.750.S	ANCN	19,05	31,0	125,0	34,5	A M6x7,5 T15F	T15F	A10.L A10.R A10T	Inch
10,0	25,4	25,4	A10.1.000.S	AT9U	25,4	37,0	150,0	34,5	A M6x7,5 T15F	T15F	A10.L A10.R A10T	Inch
10,0	20,0	20,0	A10.2020	APC9	20,0	32,0	125,0	34,5	A M6x7,5 T15F	T15F	A10.L A10.R A10T	
10,0	25,0	25,0	A10.2525	AT9Q	25,0	37,0	150,0	34,5	A M6x7,5 T15F	T15F	A10.L A10.R A10T	

Bestellbeispiel // Order example: **A10.2020**

Klemmhalter, Innenbearbeitung, Gekröpft

Gekröpfte Ausführung für passende Langdrehautomaten und Mehrspindler.

Toolholder, Internal Applications, Cranked

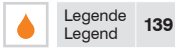
Cranked toolholder for swiss type machines.

Anzugsmoment (Schraube) // Tightening torque (screw)

7,0 Nm

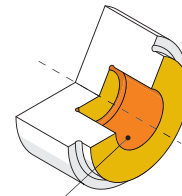
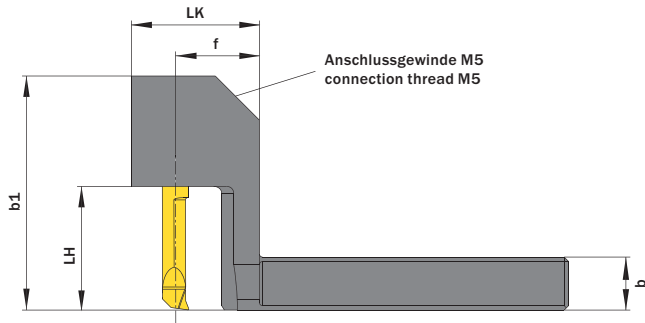
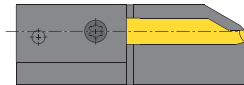
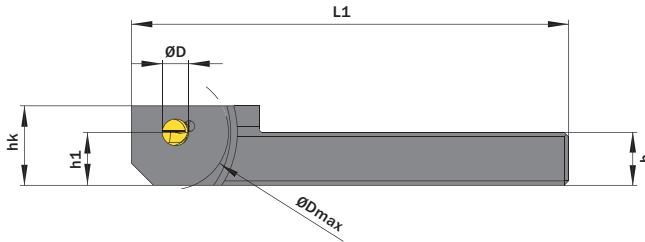
Bitte Hinweise im Anhang beachten // Please read add. notes

MASTER (Seite/Page 137)



Scan QR-Code

Oder besuchen Sie // Or Visit www.simtek.info/cp/744



- Hauptsächlich geeignet für diese Flächen
Mainly designed for these surfaces
- Je nach Schneidplatte ebenfalls möglich
Also possible depending on insert type

ØD	h	b	Artikelnummer Part number	Webcode www.simtek.com/webcode	b1	ØDmax	f	hk	h1	L1	LK	LH	Schraube Screw	Schraubenschlüssel Screw driver	Connectcode www.simtek.com/code
mm	mm	mm			mm	mm	mm	mm	mm	mm	mm	mm			
4,0	9,525	9,525	A04.0.375.10 R/L	R A5U3 L A5U5	36,5	26,0	19,0	16,0	9,52	99,0	29,0	13,0	AM6x7,5T15F	T15F	R A04.R A04C.R L A04.L A04C.L
4,0	9,525	9,525	A04.0.375.15 R/L	R AC1Z L AMDE	36,5	26,0	19,0	16,0	9,52	99,0	29,0	18,0	AM6x7,5T15F	T15F	R A04.R A04C.R L A04.L A04C.L
4,0	12,7	12,7	A04.0.500.10 R	A235	31,5	26,0	19,0	19,0	12,7	99,0	29,0	13,0	AM6x7,5T15F	T15F	A04.R A04C.R
4,0	12,7	12,7	A04.0.500.15 R/L	R AB49 L AD3A	36,5	26,0	19,0	19,0	12,7	99,0	29,0	18,0	AM6x7,5T15F	T15F	R A04.R A04C.R L A04.L A04C.L
4,0	8,0	8,0	A04.0808.10 R/L	R APYN L AA2M	31,5	26,0	19,0	14,0	8,0	99,0	29,0	13,0	AM6x7,5T15F	T15F	R A04.R A04C.R L A04.L A04C.L
4,0	8,0	8,0	A04.0808.15 R/L	R AF3M L AKCJ	36,5	26,0	19,0	14,0	8,0	99,0	29,0	18,0	AM6x7,5T15F	T15F	R A04.R A04C.R L A04.L A04C.L
4,0	10,0	10,0	A04.1010.10 R/L	R ANAT L AEØP	31,5	26,0	19,0	16,0	10,0	99,0	29,0	13,0	AM6x7,5T15F	T15F	R A04.R A04C.R L A04.L A04C.L
4,0	10,0	10,0	A04.1010.15 R/L	R AF2T L AAX5	36,5	26,0	19,0	16,0	10,0	99,0	29,0	18,0	AM6x7,5T15F	T15F	R A04.R A04C.R L A04.L A04C.L
4,0	12,0	12,0	A04.1212.10 R/L	R AHFU L ANE7	31,5	26,0	19,0	18,0	12,0	99,0	29,0	13,0	AM6x7,5T15F	T15F	R A04.R A04C.R L A04.L A04C.L
4,0	12,0	12,0	A04.1212.15 R/L	R AFNB L AEEP	36,5	26,0	19,0	18,0	12,0	99,0	29,0	18,0	AM6x7,5T15F	T15F	R A04.R A04C.R L A04.L A04C.L
4,0	16,0	16,0	A04.1616.15 R/L	R ABWP L AHM3	36,5	36,0	24,0	22,0	16,0	104,0	34,0	18,0	AM6x7,5T15F	T15F	R A04.R A04C.R L A04.L A04C.L

Verwandte Werkzeuge finden Sie auch auf der folgenden Seite!
Related Items can be found on the following page as well!

Fortgesetzte Tabelle
Continued Table

Bestellbeispiel // Order example: **A04.1616.15 R** (R = Rechte Ausführung // Right hand version)

Klemmhalter, Innenbearbeitung, Gekröpft




Gekröpfte Ausführung für passende Langdrehautomaten und Mehrspindler.


Toolholder, Internal Applications, Cranked

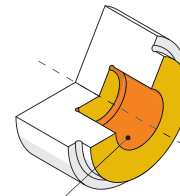
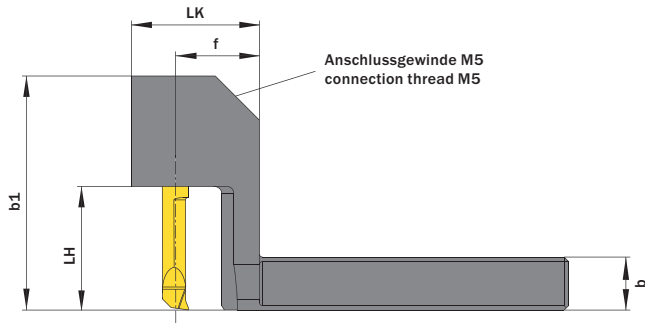
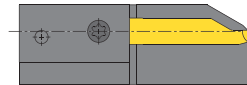
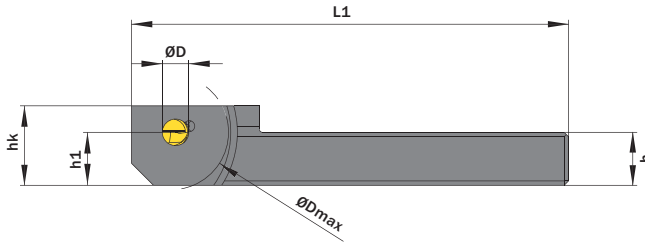
Cranked toolholder for swiss type machines.

Anzugsmoment (Schraube) // Tightening torque (screw)
7,0 Nm

Bitte Hinweise im Anhang beachten // Please read add. notes
MASTER (Seite/Page 137)




 Legende Legend **139**

 Scan QR-Code
 Oder besuchen Sie // Or Visit www.simtek.info/cp/787



- Hauptsächlich geeignet für diese Flächen
Mainly designed for these surfaces
- Je nach Schneidplatte ebenfalls möglich
Also possible depending on insert type

ØD	h	b	Artikelnummer Part number	Webcode www.simtek.com/webcode	b1	ØDmax	f	hk	h1	L1	LK	LH	Schraube Screw	Schraubenschlüssel Screw driver	Connectcode www.simtek.com/ccode
mm	mm	mm			mm	mm	mm	mm	mm	mm	mm	mm			

Fortgesetzte Tabelle Continued Table **Verwandte Werkzeuge finden Sie auch auf der vorhergehenden Seite!**
Related items can be found on the previous page as well!

▼ ØD = 5,0 mm																
5,0	9,525	9,525	A05.0.375.20 R/L	R AM2V L ANTD	48,0	26,0	19,0	16,0	9,52	99,0	29,0	23,0	A M6x7,5 T15F	T15F R	A05.R L A05.L	Inch
5,0	12,7	12,7	A05.0.500.20 R/L	R AE71 L AEMY	48,0	26,0	19,0	19,0	12,7	99,0	29,0	23,0	A M6x7,5 T15F	T15F R	A05.R L A05.L	Inch
5,0	15,875	15,875	A05.0.625.20 R/L	R ADF6 L ADØP	48,0	36,0	24,0	22,0	15,88	104,0	34,0	23,0	A M6x7,5 T15F	T15F R	A05.R L A05.L	Inch
5,0	8,0	8,0	A05.0808.15 R/L	R AG4E L ACS2	43,0	26,0	19,0	14,0	8,0	99,0	29,0	18,0	A M6x7,5 T15F	T15F R	A05.R L A05.L	
5,0	10,0	10,0	A05.1010.20 R/L	R ABQV L AA3M	48,0	26,0	19,0	16,0	10,0	99,0	29,0	23,0	A M6x7,5 T15F	T15F R	A05.R L A05.L	
5,0	12,0	12,0	A05.1212.20 R/L	R ANØ6 L AFCT	48,0	26,0	19,0	18,0	12,0	99,0	29,0	23,0	A M6x7,5 T15F	T15F R	A05.R L A05.L	
5,0	16,0	16,0	A05.1616.20 R/L	R AHKP L ABGD	48,0	36,0	24,0	22,0	16,0	104,0	34,0	23,0	A M6x7,5 T15F	T15F R	A05.R L A05.L	
▼ ØD = 6,0 mm																
6,0	9,525	9,525	A06.0.375.20 R/L	R ANYØ L AHV7	53,0	26,0	19,0	16,0	9,52	99,0	29,0	23,0	A M6x7,5 T15F	T15F R	A06.R L A06.L	Inch
6,0	12,7	12,7	A06.0.500.25 R/L	R AD7Z L ABNB	53,0	26,0	19,0	19,0	12,7	99,0	29,0	28,0	A M6x7,5 T15F	T15F R	A06.R L A06.L	Inch
6,0	15,875	15,875	A06.0.625.25 R/L	R AA7V L AD4X	53,0	36,0	24,0	22,0	15,88	104,0	34,0	28,0	A M6x7,5 T15F	T15F R	A06.R L A06.L	Inch
6,0	10,0	10,0	A06.1010.25 R/L	R ACQT L AKPG	53,0	26,0	19,0	16,0	10,0	99,0	29,0	28,0	A M6x7,5 T15F	T15F R	A06.R L A06.L	
6,0	12,0	12,0	A06.1212.25 R/L	R ABWX L AKSE	53,0	26,0	19,0	18,0	12,0	99,0	29,0	28,0	A M6x7,5 T15F	T15F R	A06.R L A06.L	
6,0	16,0	16,0	A06.1616.25 R/L	R AC3H L AD5Z	53,0	36,0	24,0	22,0	16,0	104,0	34,0	28,0	A M6x7,5 T15F	T15F R	A06.R L A06.L	
▼ ØD = 7,0 mm																
7,0	16,0	16,0	A07.1616.25 R/L	R AJJE L AEHJ	53,5	36,0	24,0	22,0	16,0	104,0	34,0	28,0	A M6x7,5 T15F	T15F R	A07.R L A07.L	

Bestellbeispiel // Order example: **A05.1616.20 R** (R = Rechte Ausführung // Right hand version)

Doppelklemmhalter, Innenbearbeitung

Doppelklemmhalter für passende Langdrehautomaten.

Toolholder, Internal Applications

Double toolholder for swiss type machines.

Anzugsmoment (Schraube) // Tightening torque (screw)

7,0 Nm

Bitte Hinweise im Anhang beachten // Please read add. notes

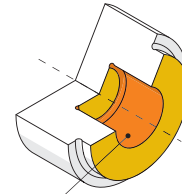
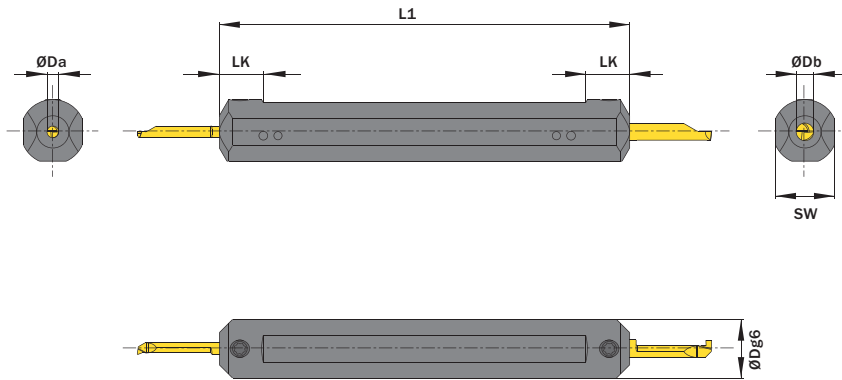
MASTER (Seite/Page 137)



TW Legende
ST Legend **139**

Scan QR-Code

Oder besuchen Sie // Or Visit www.simtek.info/cp/742



- Hauptsächlich geeignet für diese Flächen
Mainly designed for these surfaces
- Je nach Schneidplatte ebenfalls möglich
Also possible depending on insert type

Abbildung zeigt / Drawing shows: A04.0.750.0140.A06

ØDa	ØDg6	L1	ØDb	Artikelnummer Part number	Webcode www.simtek.com/webcode	LK	SW	Schraube Screw	Schraubenschlüssel Screw driver	Connectcode www.simtek.com/code
mm	mm	mm	mm			mm	mm			
▼ ØDa = 4,0 mm										
4,0	19,05	140,0	6,0	A04.0.750.0140.A06	AHWS	15,0	17,0	A M6x7,5 T15F	T15F	A04.L A04.R A04CL A04.C.R A06.L A06.R
4,0	20,0	140,0	4,0	A04.0020.0140.A04	APJQ	15,0	17,0	A M6x7,5 T15F	T15F	A04.L A04.R A04CL A04C.R
4,0	20,0	140,0	5,0	A04.0020.0140.A05	AMF0	15,0	17,0	A M6x7,5 T15F	T15F	A04.L A04.R A04CL A04.C.R A05.L A05.R
4,0	20,0	140,0	6,0	A04.0020.0140.A06	AAWT	15,0	18,0	A M6x7,5 T15F	T15F	A04.L A04.R A04CL A04.C.R A06.L A06.R
4,0	22,0	140,0	4,0	A04.0022.0140.A04	AGV1	15,0	20,0	A M6x7,5 T15F	T15F	A04.L A04.R A04CL A04C.R
4,0	22,0	140,0	6,0	A04.0022.0140.A06	AA6P	15,0	20,0	A M6x7,5 T15F	T15F	A04.L A04.R A04CL A04.C.R A06.L A06.R
4,0	25,0	140,0	6,0	A04.0025.0140.A06	AEZP	15,0	23,0	A M6x7,5 T15F	T15F	A04.L A04.R A04CL A04.C.R A06.L A06.R
4,0	28,0	140,0	6,0	A04.0028.0140.A06	AB7A	15,0	26,0	A M6x7,5 T15F	T15F	A04.L A04.R A04CL A04.C.R A06.L A06.R
▼ ØDa = 5,0 mm										
5,0	20,0	140,0	5,0	A05.0020.0140.A05	AK9Y	15,0	17,0	A M6x7,5 T15F	T15F	A05.L A05.R
5,0	20,0	140,0	6,0	A05.0020.0140.A06	APND	15,0	17,0	A M6x7,5 T15F	T15F	A05.L A05.R A06.L A06.R
▼ ØDa = 6,0 mm										
6,0	20,0	140,0	6,0	A06.0020.0140.A06	AGXT	15,0	17,0	A M6x7,5 T15F	T15F	A06.L A06.R
6,0	22,0	140,0	6,0	A06.0022.0140.A06	AJC6	15,0	19,0	A M6x7,5 T15F	T15F	A06.L A06.R

Bestellbeispiel // Order example: **A04.0022.0140.A06**

Klemmhalter, Innenbearbeitung

SIMTEK Trägerwerkzeug mit Polygonschaft nach ISO 26623 zum Drehen und Fräsen.

Toolholder, Internal Applications

SIMTEK toolholder with polygon shank according to ISO 26623 for turning and milling applications.

Anzugsmoment (Schraube) // Tightening torque (screw)

7,0 Nm

Bitte Hinweise im Anhang beachten // Please read add. notes

MASTER (Seite/Page 137)



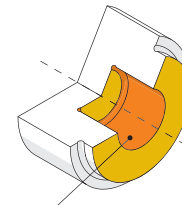
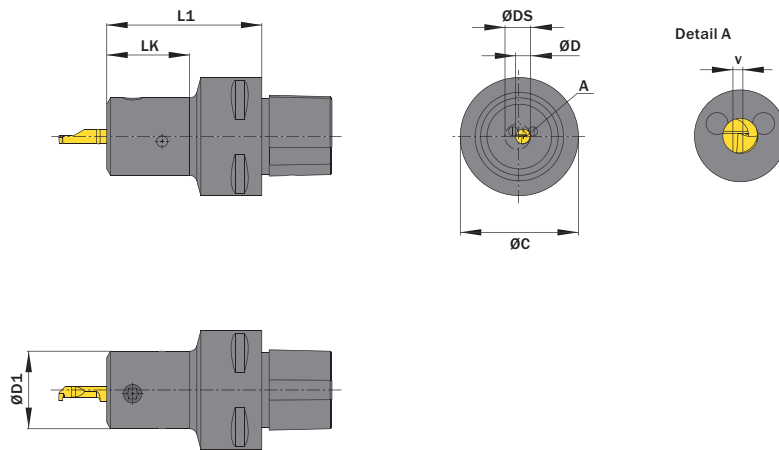
Legende
Legend

139



Scan
QR-Code

Oder besuchen Sie // Or Visit
www.simtek.info/cp/737



- Hauptsächlich geeignet für diese Flächen
Mainly designed for these surfaces
- Je nach Schneidplatte ebenfalls möglich
Also possible depending on insert type

Abbildung zeigt / Drawing shows: A04.00C3.05

Polygonschaftgröße Polygon shank size	ØD mm	ØC mm	ØDS mm	Artikelnummer Part number	Webcode www.simtek.com/webcode	ØD1 mm	ØDmin (Min. Bohrung) ØDmin (min. bore) mm	L1 mm	LK mm	Maximale Frästiefe Max. depth of cut (milling) mm	V mm	Schraube Screw	Schraubenschlüssel Screw driver	Connectcode www.simtek.com/code	
															upd
▼ ØD = 4,0 mm															
C3	4,0	32,0	5,9	A04.00C3.05	ADDV	21,0	6,4	42,0	22,0	0,75	1,0	A M6x7,5 T15F	T15F	A04.L A04.R A04.C.L A04.C.R	upd
C4	4,0	40,0	5,9	A04.00C4.05	ADV4	21,0	6,4	47,0	22,0	0,75	1,0	A M6x7,5 T15F	T15F	A04.L A04.R A04.C.L A04.C.R	upd
C5	4,0	50,0	6,0	A04.00C5.06	AUFJ	21,0	6,5	49,0	22,0	0,8	1,05	A M6x7,5 T15F	T15F	A04.L A04.R A04.C.L A04.C.R	upd
▼ ØD = 5,0 mm															
C3	5,0	32,0	6,9	A05.00C3.07	APX4	22,0	7,4	42,0	22,0	0,7	1,0	A M6x7,5 T15F	T15F	A05.L A05.R	upd
C5	5,0	50,0	7,5	A05.00C5.08	AUFK	22,0	8,0	49,0	22,0	1,0	1,3	A M6x7,5 T15F	T15F	A05.L A05.R	upd

Verwandte Werkzeuge finden Sie auch auf der folgenden Seite!
Related Items can be found on the following page as well!

Fortgesetzte Tabelle
Continued Table

Bestellbeispiel // Order example: **A04.00C4.05**

Klemmhalter, Innenbearbeitung

SIMTEK Trägerwerkzeug mit Polygonschaft nach ISO 26623 zum Drehen und Fräsen.

Toolholder, Internal Applications

SIMTEK toolholder with polygon shank according to ISO 26623 for turning and milling applications.

Anzugsmoment (Schraube) // Tightening torque (screw)

7,0 Nm

Bitte Hinweise im Anhang beachten // Please read add. notes

MASTER (Seite/Page 137)



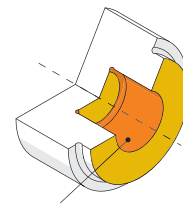
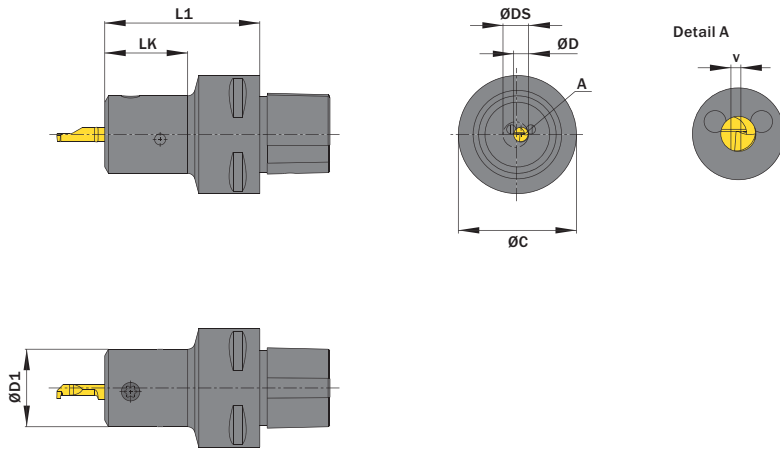
Legende
Legend

139



Scan
QR-Code

Oder besuchen Sie // Or Visit
www.simtek.info/cp/973



- Hauptsächlich geeignet für diese Flächen
Mainly designed for these surfaces
- Je nach Schneidplatte ebenfalls möglich
Also possible depending on insert type

Abbildung zeigt / Drawing shows: A04.00C3.05

Polgonschaftgröße Polygon shank size	ØD	ØC	ØDS	Artikelnummer Part number	Webcode www.simtek.com/webcode	ØD1	ØDmin (Min. Bohrung) ØDmin (min. bore)	L1	LK	Maximale Frästiefe Max. depth of cut (milling)	V	Schraube Screw	Schraubenschlüssel Screw driver	Connectcode www.simtek.com/code
	mm	mm	mm			mm	mm	mm	mm	mm	mm			

Fortgesetzte Tabelle
Continued Table

Verwandte Werkzeuge finden Sie auch auf der vorhergehenden Seite!
Related items can be found on the previous page as well!

▼ ØD = 6,0 mm															
C3	6,0	32,0	7,9	A06.00C3.08	AHG5	23,0	8,4	42,0	22,0	0,65	1,0	AM6x7,5T15F	T15F	A06.L A06.R	upd
C3	6,0	32,0	9,8	A06.00C3.10	ABBP	23,5	10,3	42,0	22,0	1,6	1,95	AM6x7,5T15F	T15F	A06.L A06.R	upd
C4	6,0	40,0	7,9	A06.00C4.08	AEU0	23,0	8,4	47,0	22,0	0,65	1,0	AM6x7,5T15F	T15F	A06.L A06.R	upd
C4	6,0	40,0	9,8	A06.00C4.10	ADS1	23,5	10,3	47,0	22,0	1,6	1,95	AM6x7,5T15F	T15F	A06.L A06.R	upd
C5	6,0	50,0	9,8	A06.00C5.10	AUFM	23,5	10,3	49,0	22,0	1,6	1,95	AM6x7,5T15F	T15F	A06.L A06.R	upd
C6	6,0	63,0	9,8	A06.00C6.10	AUFS	23,5	10,3	95,0	22,0	1,6	1,95	AM6x7,5T15F	T15F	A06.L A06.R	upd
▼ ØD = 7,0 mm															
C3	7,0	32,0	8,9	A07.00C3.09	AN85	24,0	9,4	42,0	22,0	0,6	1,0	AM6x7,5T15F	T15F	A07.L A07.R	upd
C3	7,0	32,0	12,7	A07.00C3.13	AM7H	25,0	13,2	42,0	22,0	2,5	2,9	AM6x7,5T15F	T15F	A07.L A07.R	upd
C4	7,0	40,0	8,9	A07.00C4.09	AMBV	24,0	9,4	47,0	22,0	0,6	1,0	AM6x7,5T15F	T15F	A07.L A07.R	upd
C4	7,0	40,0	12,7	A07.00C4.13	AM83	25,0	13,2	47,0	22,0	2,5	2,9	AM6x7,5T15F	T15F	A07.L A07.R	upd
C5	7,0	50,0	12,7	A07.00C5.13	AUFN	25,0	13,2	49,0	22,0	2,5	2,9	AM6x7,5T15F	T15F	A07.L A07.R	upd
C6	7,0	63,0	12,7	A07.00C6.13	AUFT	25,0	13,2	95,0	22,0	2,5	2,9	AM6x7,5T15F	T15F	A07.L A07.R	upd

Bestellbeispiel // Order example: **A06.00C4.08**

Klemmhalter, Innenbearbeitung


Geeignet zum Fräsen und Ausspindeln.



Toolholder, Internal Applications

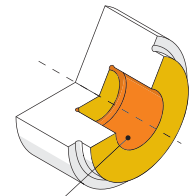
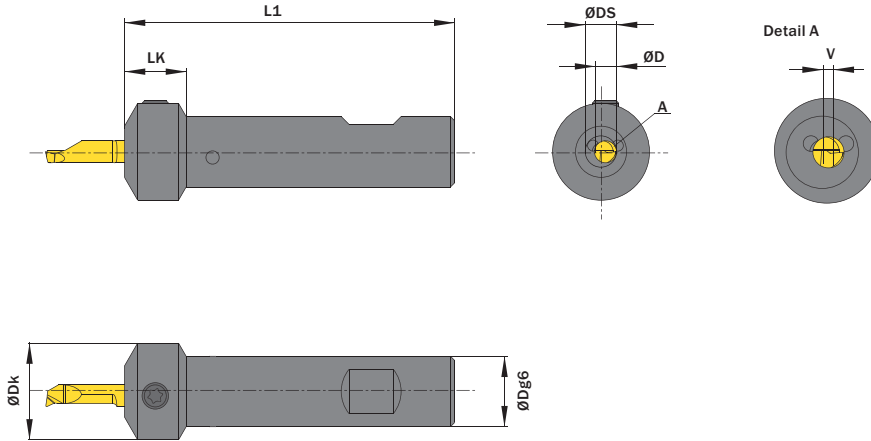
For milling and boring applications.

Anzugsmoment (Schraube) // Tightening torque (screw)
7,0 Nm

Bitte Hinweise im Anhang beachten // Please read add. notes
MASTER (Seite/Page 137)

TW **ST**  **Legende** **139**
Legend

  **Scan QR-Code** Oder besuchen Sie // Or Visit **www.simtek.info/cp/743**



- Hauptsächlich geeignet für diese Flächen
Mainly designed for these surfaces
- Je nach Schneidplatte ebenfalls möglich
Also possible depending on insert type

Abbildung zeigt / Drawing shows: A05.0016.07 B ST

ØD	ØDg6	ØDS	Artikelnummer Part number	Webcode www.simtek.com/webcode	ØDk	L1	LK	V	Schraube Screw	Schraubenschlüssel Screw driver	Connectcode www.simtek.com/code	
mm	mm	mm			mm	mm	mm	mm				
▼ ØD = 4,0 mm												
4,0	15,875	5,9	A04.0.625.05 B ST	A5U7	21,0	75,0	14,0	1,0	AM6x7,5 T15F	T15F	A04.L A04.R	new inch
4,0	16,0	5,9	A04.0016.05 B ST	APUS	21,0	75,0	14,0	1,0	AM6x7,5 T15F	T15F	A04.L A04.R	
4,0	16,0	6,0	A04.0016.06 B ST	AB4A	21,0	75,0	14,0	1,05	AM6x7,5 T15F	T15F	A04.L A04.R	
▼ ØD = 5,0 mm												
5,0	15,875	6,9	A05.0.625.07 B ST	A5U9	22,0	75,0	14,0	1,0	AM6x7,5 T15F	T15F	A05.L A05.R	new inch
5,0	16,0	6,9	A05.0016.07 B ST	AMBQ	22,0	75,0	14,0	1,0	AM6x7,5 T15F	T15F	A05.L A05.R	
5,0	16,0	7,5	A05.0016.08 B ST	AE97	22,0	75,0	14,0	1,3	AM6x7,5 T15F	T15F	A05.L A05.R	
▼ ØD = 6,0 mm												
6,0	15,875	9,8	A06.0.625.10 B ST	A5VB	22,0	75,0	14,0	1,95	AM6x7,5 T15F	T15F	A06.L A06.R	new inch
6,0	16,0	9,8	A06.0016.10 B ST	AC9M	22,0	75,0	14,0	1,95	AM6x7,5 T15F	T15F	A06.L A06.R	
▼ ØD = 7,0 mm												
7,0	15,875	12,7	A07.0.625.13 B ST	A5VD	22,0	75,0	14,0	2,9	AM6x7,5 T15F	T15F	A07.L A07.R	new inch
7,0	16,0	12,7	A07.0016.13 B ST	AH14	22,0	75,0	14,0	2,9	AM6x7,5 T15F	T15F	A07.L A07.R	

Bestellbeispiel // Order example: **A06.0016.10 B ST**

Klemmhalter, Innenbearbeitung, für Star-Maschinen

Für die Drehbearbeitung innen.

Toolholder, Internal Applications, for Star-Machines

For internal turning applications.

Anzugsmoment (Schraube) // Tightening torque (screw)

7,0 Nm

Bitte Hinweise im Anhang beachten // Please read add. notes

MASTER (Seite/Page 137)



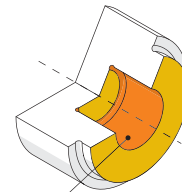
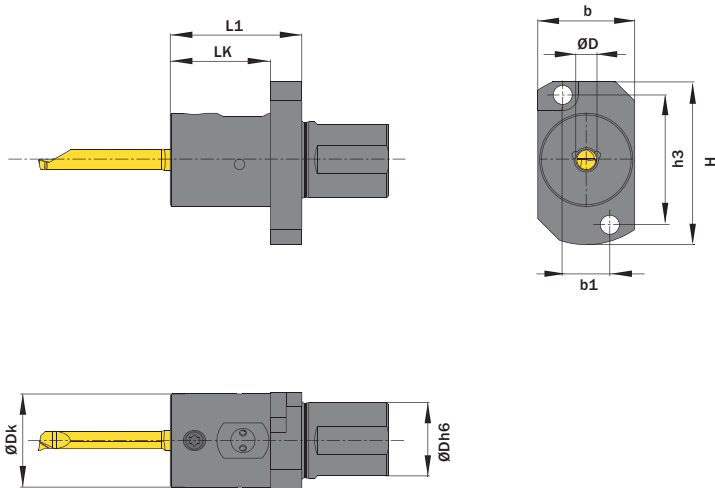
Legende
Legend

139



Scan
QR-Code

Oder besuchen Sie // Or Visit
www.simtek.info/cp/748



- Hauptsächlich geeignet für diese Flächen
Mainly designed for these surfaces
- Je nach Schneidplatte ebenfalls möglich
Also possible depending on insert type

Abbildung zeigt / Drawing shows: A06.ST22

ØD	ØDh6	Artikelnummer Part number	Webcode www.simtek.com/webcode	b	b1	ØDk	H	h3	L1	LK	Schraube Screw	Schraubenschlüssel Screw driver	Connectcode www.simtek.com/code
mm	mm			mm	mm	mm	mm	mm	mm	mm			
▼ ØD = 4,0 mm													
4,0	22,0	A04.ST22	ANWS	28,0	13,6	26,9	47,0	37,5	38,0	29,0	AM6x7,5 T15F	T15F	A04.L A04.R A04C.L A04C.R
▼ ØD = 5,0 mm													
5,0	22,0	A05.ST22	AJQC	28,0	13,6	26,9	47,0	37,5	38,0	29,0	AM6x7,5 T15F	T15F	A05.L A05.R
▼ ØD = 6,0 mm													
6,0	22,0	A06.ST22	AKAU	28,0	13,6	26,9	47,0	37,5	38,0	29,0	AM6x7,5 T15F	T15F	A06.L A06.R
▼ ØD = 7,0 mm													
7,0	22,0	A07.ST22	ACP1	28,0	13,6	26,9	47,0	37,5	38,0	29,0	AM6x7,5 T15F	T15F	A07.L A07.R

Bestellbeispiel // Order example: **A06.ST22**

Klemmhalter, Innenbearbeitung, für Star-Maschinen

Für die Drehbearbeitung innen.
Vier Kühlmittelzufuhrarten je nach Bedarf einstellbar.

Toolholder, Internal Applications, for Star-Machines

For internal turning applications.
Four different types of through coolant supply can be realized as required.

Anzugsmoment (Schraube) // Tightening torque (screw)

7,0 Nm

Bitte Hinweise im Anhang beachten // Please read add. notes

MASTER (Seite/Page 137)



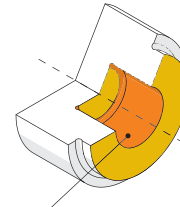
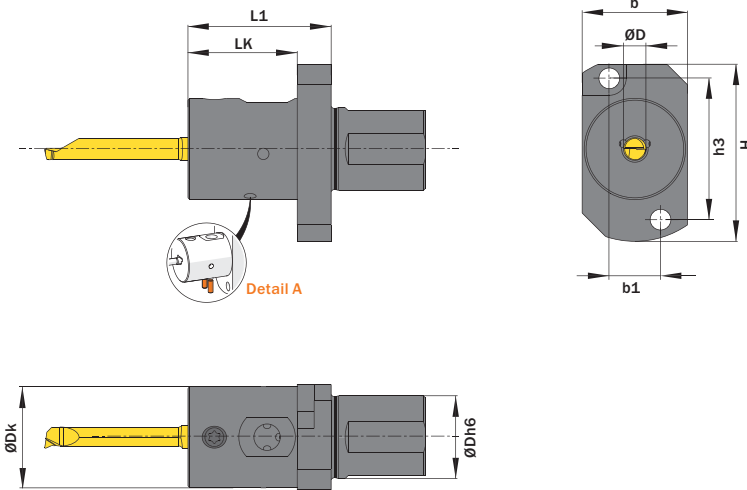
Legende
Legend

139



Scan
QR-Code

Oder besuchen Sie // Or Visit
www.simtek.info/cp/1234



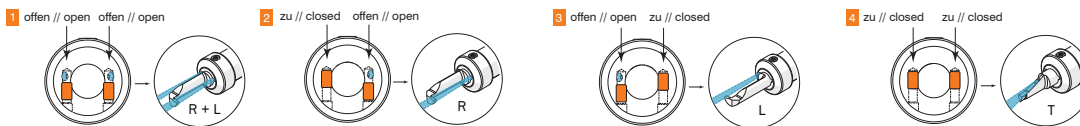
- Hauptsächlich geeignet für diese Flächen
Mainly designed for these surfaces
- Je nach Schneidplatte ebenfalls möglich
Also possible depending on insert type

Abbildung zeigt / Drawing shows: A04.ST22 T

ØD	ØDh6	Artikelnummer Part number	Webcode www.simtek.com/webcode	b	b1	ØDk	H	h3	L1	LK	Schraube Screw	Schraubenschlüssel Screw driver	Connectcode www.simtek.com/ccode	upd
4,0	22,0	A04.ST22 T	AZ4A	28,0	13,6	26,9	47,0	37,5	38,0	29,0	A M6x7,5 T15F	T15F	A04.L A04.R A04CL A04C.R A04T	upd
5,0	22,0	A05.ST22 T	AZ39	28,0	13,6	26,9	47,0	37,5	38,0	29,0	A M6x7,5 T15F	T15F	A05.L A05.R A05T	upd
6,0	22,0	A06.ST22 T	AZ38	28,0	13,6	26,9	47,0	37,5	38,0	29,0	A M6x7,5 T15F	T15F	A06.L A06.R A06T	upd
7,0	22,0	A07.ST22 T	AZ37	28,0	13,6	26,9	47,0	37,5	38,0	29,0	A M6x7,5 T15F	T15F	A07.L A07.R A07T	upd
8,0	22,0	A08.ST22 T	AZVB	28,0	13,6	26,9	47,0	37,5	38,0	29,0	A M6x7,5 T15F	T15F	A08 A08T	upd

Bestellbeispiel // Order example: **A04.ST22 T**

Detail A | 1 Halter - 4 Kühlmittelzufuhrarten // 1 Toolholder - 4 types of coolant supply



simturn AX
simturn DX
simturn PX
simturn H2
simturn K2
simturn C4
simturn GX
simturn E3
simturn E12
simturn FX
simturn Decolletage
simturn OA
Index

Grundhalter mit WFB-Aufnahme

Grundhalter mit WFB-Aufnahme,
 vier verschiedene Kühlmittelzufuhrarten individuell einstellbar.

Base toolholder with WFB-adapter

Base toolholder with WFB-adapter. Four different types of
 through coolant supply can be realized as required.

Anzugsmoment (Schraube) // Tightening torque (screw)

7,0 Nm

Bitte Hinweise im Anhang beachten // Please read add. notes

MASTER (Seite/Page 137)



Legende
 Legend **139**



Scan
 QR-Code

Oder besuchen Sie // Or Visit
www.simtek.info/cp/1358

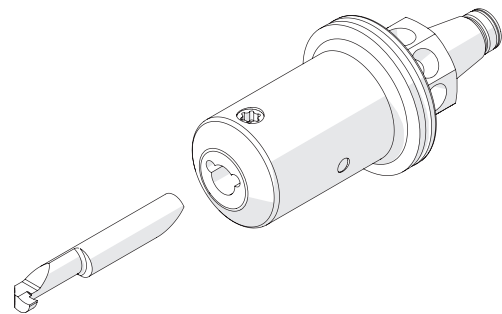
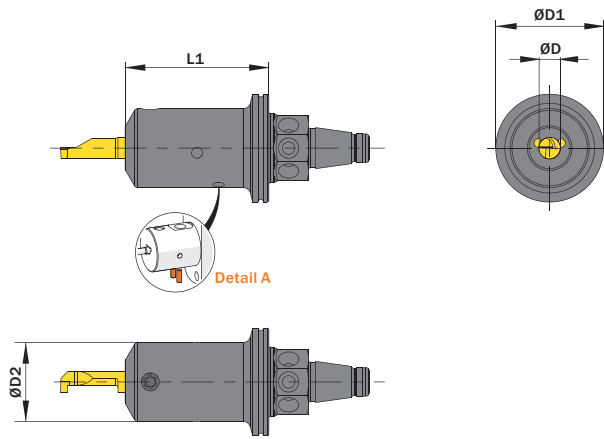


Abbildung zeigt / Drawing shows: A00.WF22.40

ØD2	L1	Artikelnummer Part number	Webcode www.simtek.com/webcode	ØD1	Schraube Screw	Schraubenschlüssel Screw driver	Connectcode www.simtek.com/ccode	
mm	mm			mm				
22,0	40,0	A04.WF22.40 T	A6TN	30,0	A M6x7,5 T15F	T15F	A04.L A04.R A04C.L A04C.R A04T	new
22,0	40,0	A05.WF22.40 T	A6TQ	30,0	A M6x7,5 T15F	T15F	A05.L A05.R A05T	new
22,0	40,0	A06.WF22.40 T	A6TT	30,0	A M6x7,5 T15F	T15F	A06.L A06.R A06T	new
22,0	40,0	A07.WF22.40 T	A6TV	30,0	A M6x7,5 T15F	T15F	A07.L A07.R A07T	new
22,0	40,0	A08.WF22.40 T	A6TX	30,0	A M6x7,5 T15F	T15F	A08 A08T	new
22,0	40,0	A10.WF22.40 T	A6TZ	30,0	A M6x7,5 T15F	T15F	A10 A10.L A10.R A10T	new

Bestellbeispiel // Order example: **A10.WF22.40 T**

Klemmhalter, Innenbearbeitung, für Star-Maschinen

Für die Drehbearbeitung innen.
Vier Kühlmittelzufuhrarten je nach Bedarf einstellbar.

Toolholder, Internal Applications, for Star-Machines

For internal turning applications.
Four different types of through coolant supply can be realized as required.

Anzugsmoment (Schraube) // Tightening torque (screw)

7,0 Nm

Bitte Hinweise im Anhang beachten // Please read add. notes

MASTER (Seite/Page 137)



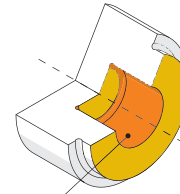
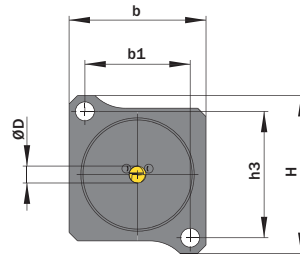
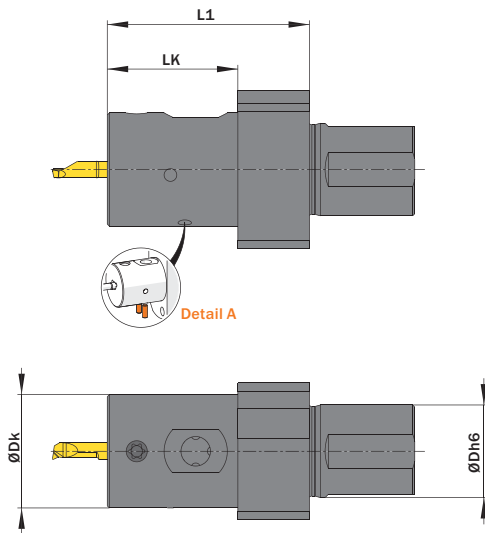
Legende
Legend

139



Scan
QR-Code

Oder besuchen Sie // Or Visit
www.simtek.info/cp/1291



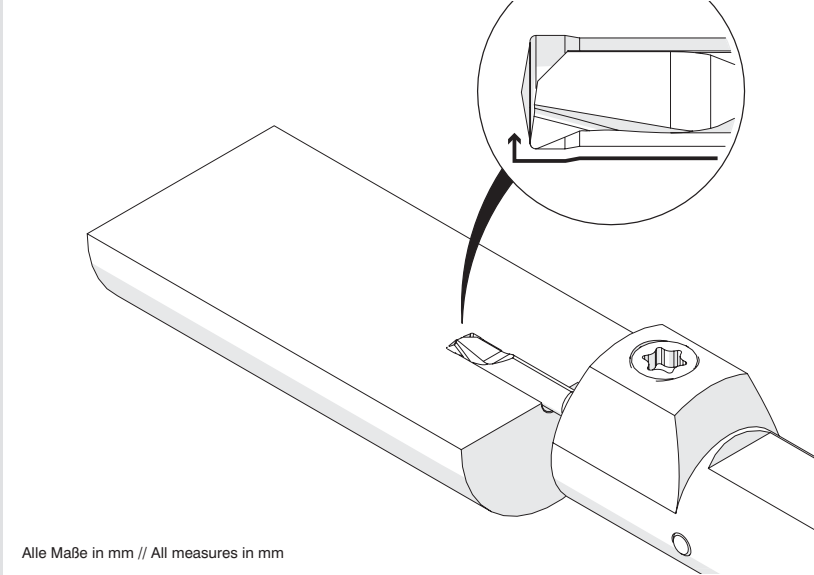
- Hauptsächlich geeignet für diese Flächen
Mainly designed for these surfaces
- Je nach Schneidplatte ebenfalls möglich
Also possible depending on insert type

Abbildung zeigt / Drawing shows: A04.ST22.A T

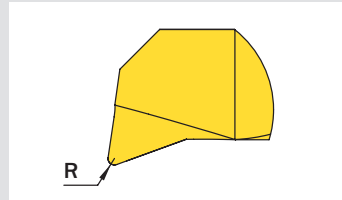
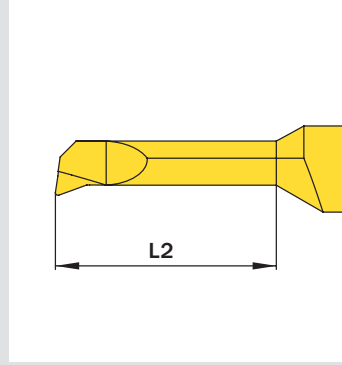
ØD	ØDh6	Artikelnummer Part number	Webcode www.simtek.com/webcode	b	b1	ØDk	H	h3	L1	LK	Schraube Screw	Schraubenschlüssel Screw driver	Connectcode www.simtek.com/code	
4,0	22,0	A04.ST22.A T	A2Q4	32,5	25,0	26,9	37,5	30,0	48,0	31,0	A M6x7,5T15F	T15F	A04L A04R A04CL A04C.R A04T	new
5,0	22,0	A05.ST22.A T	A2Q6	32,5	25,0	26,9	37,5	30,0	48,0	31,0	A M6x7,5T15F	T15F	A05L A05R A05T	new
6,0	22,0	A06.ST22.A T	A2Q8	32,5	25,0	26,9	37,5	30,0	48,0	31,0	A M6x7,5T15F	T15F	A06L A06R A06T	new
7,0	22,0	A07.ST22.A T	A2SA	32,5	25,0	26,9	37,5	30,0	48,0	31,0	A M6x7,5T15F	T15F	A07L A07R A07T	new
8,0	22,0	A08.ST22.A T	A2SC	32,5	25,0	26,9	37,5	30,0	48,0	31,0	A M6x7,5T15F	T15F	A08 A08T	new

Bestellbeispiel // Order example: **A06.ST22.A T**

Ausdrehen Boring



Alle Maße in mm // All measures in mm



Artikelnummer Part number	ØDmin (Min. Bohrung) ØDmin (min. bore)	L2	R	siehe Seite see Page
A04.5015.01.03.00 YR/L	0,3	1,2	-	71
A04.5C15.01.03.00 YR/L	0,3	1,2	-	71
A04.5020.01.04.00 YR/L	0,4	1,6	-	71
A04.5C20.01.04.00 YR/L	0,4	1,6	-	71
A04.5025.02.05.00 YR/L	0,5	2,0	-	71
A04.5C25.02.05.00 YR/L	0,5	2,0	-	71
A04.5030.02.06.00 YR/L	0,6	2,5	-	71
A04.5C30.02.06.00 YR/L	0,6	2,5	-	71
A04.5035.03.07.00 YR/L	0,7	3,6	-	71
A04.5C35.03.07.00 YR/L	0,7	3,6	-	71
A04.5040.04.08.00 YR/L	0,8	4,1	-	71
A04.5C40.04.08.00 YR/L	0,8	4,1	-	71
A04.5045.05.09.00 YR/L	0,9	5,1	-	71
A04.5C45.05.09.00 YR/L	0,9	5,1	-	71
A04.1804.04.10.05 YR/L	1,0	4,1	0,05	72
A04.1C04.04.10.05 YR/L	1,0	4,1	0,05	72
A04.1804.04.10.10 YR/L	1,0	4,1	0,1	72
A04.1C04.04.10.10 YR/L	1,0	4,1	0,1	72
A04.1804.06.10.05 YR/L	1,0	6,1	0,05	72
A04.1C04.06.10.05 YR/L	1,0	6,1	0,05	72
A04.1804.06.10.10 YR/L	1,0	6,1	0,1	72
A04.1C04.06.10.10 YR/L	1,0	6,1	0,1	72
A04.1805.07.12.10 YR/L	1,2	7,1	0,1	72
A04.1C05.07.12.10 YR/L	1,2	7,1	0,1	72
A04.1805.09.12.10 YR/L	1,2	9,1	0,1	72
A04.1C05.09.12.10 YR/L	1,2	9,1	0,1	72
A04.1806.06.14.10 YR/L	1,4	6,1	0,1	72
A04.1C06.06.14.10 YR/L	1,4	6,1	0,1	72
A04.1806.10.14.10 YR/L	1,4	10,2	0,1	72
A04.1C06.10.14.10 YR/L	1,4	10,2	0,1	72
A04.1807.06.17.05 YR/L	1,7	6,1	0,05	73
A04.1C07.06.17.05 YR/L	1,7	6,1	0,05	73
A04.1807.06.17.10 YR/L	1,7	6,1	0,1	73
A04.1C07.06.17.10 YR/L	1,7	6,1	0,1	73
A04.1807.09.17.05 YR/L	1,7	9,1	0,05	73
A04.1C07.09.17.05 YR/L	1,7	9,1	0,05	73
A04.1807.09.17.10 YR/L	1,7	9,1	0,1	73
A04.1C07.09.17.10 YR/L	1,7	9,1	0,1	73
A04.1807.12.17.10 YR/L	1,7	12,2	0,1	73
A04.1C07.12.17.10 YR/L	1,7	12,2	0,1	73
A04.1808.09.19.10 YR/L	1,9	9,1	0,1	73
A04.1C08.09.19.10 YR/L	1,9	9,1	0,1	73
A04.1808.12.19.10 YR/L	1,9	12,2	0,1	73
A04.1C08.12.19.10 YR/L	1,9	12,2	0,1	73
A04.1808.13.19.10 YR/L	1,9	13,2	0,1	73
A04.1C08.13.19.10 YR/L	1,9	13,2	0,1	73
A04.1810.06.22.05 YR/L	2,2	6,1	0,05	74
A04.1C10.06.22.05 YR/L	2,2	6,1	0,05	74

Artikelnummer Part number	ØDmin (Min. Bohrung) ØDmin (min. bore)	L2	R	siehe Seite see Page
A04.1810.06.22.10 YR/L	2,2	6,1	0,1	74
A04.1C10.06.22.10 YR/L	2,2	6,1	0,1	74
A04.1810.09.22.05 YR/L	2,2	9,1	0,05	74
A04.1C10.09.22.05 YR/L	2,2	9,1	0,05	74
A04.1810.09.22.10 YR/L	2,2	9,1	0,1	74
A04.1C10.09.22.10 YR/L	2,2	9,1	0,1	74
A04.1810.13.22.10 YR/L	2,2	13,2	0,1	74
A04.1C10.13.22.10 YR/L	2,2	13,2	0,1	74
A04.1C10.15.22.10 YR	2,2	15,2	0,1	74
A04.1812.10.27.03 YR/L	2,7	10,2	0,03	74
A04.1C12.10.27.03 YR/L	2,7	10,2	0,03	74
A04.1812.10.27.05 YR/L	2,7	10,2	0,05	74
A04.1C12.10.27.05 YR/L	2,7	10,2	0,05	74
A04.1812.10.27.15 YR/L	2,7	10,2	0,15	74
A04.1C12.10.27.15 YR/L	2,7	10,2	0,15	74
A04.1812.15.27.05 YR/L	2,7	15,2	0,05	74
A04.1C12.15.27.05 YR/L	2,7	15,2	0,05	74
A04.1812.15.27.15 YR/L	2,7	15,2	0,15	74
A04.1C12.15.27.15 YR/L	2,7	15,2	0,15	74
A04.1814.20.30.15 YR/L	3,0	20,3	0,15	75
A04.1C14.20.30.15 YR/L	3,0	20,3	0,15	75
A04.1814.25.30.05 YR/L	3,0	25,4	0,05	75
A04.1C14.25.30.05 YR/L	3,0	25,4	0,05	75
A04.1815.10.32.03 YR/L	3,2	10,2	0,03	75
A04.1C15.10.32.03 YR/L	3,2	10,2	0,03	75
A04.1815.10.32.05 YR/L	3,2	10,2	0,05	75
A04.1C15.10.32.05 YR/L	3,2	10,2	0,05	75
A04.1815.10.32.15 YR/L	3,2	10,2	0,15	75
A04.1C15.10.32.15 YR/L	3,2	10,2	0,15	75
A04.1815.15.32.05 YR/L	3,2	15,2	0,05	75
A04.1C15.15.32.05 YR/L	3,2	15,2	0,05	75
A04.1815.15.32.15 YR/L	3,2	15,2	0,15	75
A04.1C15.15.32.15 YR/L	3,2	15,2	0,15	75
A04.1815.20.32.05 YR/L	3,2	20,3	0,05	75
A04.1C15.20.32.05 YR/L	3,2	20,3	0,05	75
A04.1815.20.32.15 YR/L	3,2	20,3	0,15	75
A04.1C15.20.32.15 YR/L	3,2	20,3	0,15	75
A04.1815.25.32.15 YR	3,2	25,4	0,15	75
A04.1C17.10.37.15 YR/L	3,7	10,2	0,15	76
A04.1817.10.37.15 YR/L	3,7	10,2	0,15	76
A04.1817.15.37.15 YR/L	3,7	15,2	0,15	76
A04.1C17.15.37.15 YR/L	3,7	15,2	0,15	76
A04.1817.20.37.05 YR/L	3,7	20,3	0,05	76
A04.1C17.20.37.05 YR/L	3,7	20,3	0,05	76
A04.1817.20.37.15 YR/L	3,7	20,3	0,15	76
A04.1C17.20.37.15 YR/L	3,7	20,3	0,15	76
A04.1817.25.37.10 YR/L	3,7	25,4	0,1	76
A04.1C17.25.37.10 YR/L	3,7	25,4	0,1	76
A04.1C17.30.37.10 YR	3,7	30,5	0,1	76
A04.1820.10.42.03 YR/L	4,2	10,2	0,03	77

Artikelnummer Part number	ØDmin (Min. Bohrung) ØDmin (min. bore)	L2	R	siehe Seite see Page
A04.1820.10.42.05 YR/L	4,2	10,2	0,05	77
A04.1820.10.42.15 YR/L	4,2	10,2	0,15	77
A04.1820.15.42.03 YR/L	4,2	15,2	0,03	77
A04.1820.15.42.05 YR/L	4,2	15,2	0,05	77
A04.1820.15.42.15 YR/L	4,2	15,2	0,15	77
A04.1820.20.42.03 YR/L	4,2	20,3	0,03	77
A04.1820.20.42.05 YR/L	4,2	20,3	0,05	77
A04.1820.20.42.15 YR/L	4,2	20,3	0,15	77
A04.1820.25.42.05 YR/L	4,2	25,4	0,05	77
A04.1820.25.42.15 YR/L	4,2	25,4	0,15	77
A04.1820.30.42.05 YR/L	4,2	30,5	0,05	77
A04.1820.35.42.05 YR	4,2	35,6	0,05	77
A05.1825.20.49.20 YR/L	4,9	20,3	0,2	78
A05.1825.25.49.20 YR/L	4,9	25,4	0,2	78
A05.1825.30.49.05 YR/L	4,9	30,5	0,05	78
A05.1825.30.49.20 YR/L	4,9	30,5	0,2	78
A05.1825.35.49.20 YR/L	4,9	35,6	0,2	78
A05.1825.40.49.20 YR/L	4,9	40,6	0,2	78
A05.1825.10.52.05 YR/L	5,2	10,2	0,05	79
A05.1825.10.52.20 YR/L	5,2	10,2	0,2	79
A05.1825.15.52.03 YR/L	5,2	15,2	0,03	79
A05.1825.15.52.05 YR/L	5,2	15,2	0,05	79
A05.1825.15.52.20 YR/L	5,2	15,2	0,2	79
A05.1825.20.52.05 YR/L	5,2	20,3	0,05	79
A05.1825.20.52.20 YR/L	5,2	20,3	0,2	79
A05.1825.25.52.20 YR/L	5,2	25,4	0,2	79
A05.1825.30.52.05 YR/L	5,2	30,5	0,05	79
A05.1825.30.52.20 YR/L	5,2	30,5	0,2	79
A05.1825.35.52.20 YR/L	5,2	35,6	0,2	79
A06.1830.35.59.20 YR/L	5,9	35,6	0,2	80
A06.1830.40.59.20 YR/L	5,9	40,6	0,2	80
A06.1830.45.59.20 YR	5,9	45,7	0,2	80
A06.1830.15.62.20 YR/L	6,2	15,2	0,2	81
A06.1830.20.62.05 YR/L	6,2	20,3	0,05	81
A06.1830.20.62.20 YR/L	6,2	20,3	0,2	81
A06.1830.25.62.20 YR/L	6,2	25,4	0,2	81
A06.1830.30.62.05 YR/L	6,2	30,5	0,05	81
A06.1830.30.62.20 YR/L	6,2	30,5	0,2	81
A06.1830.35.62.20 YR/L	6,2	35,6	0,2	81
A06.1830.40.62.20 YR/L	6,2	40,6	0,2	81
A06.1830.50.62.20 YR/L	6,2	50,8	0,2	81
A07.1835.25.72.20 YR/L	7,2	25,4	0,2	81
A07.1835.30.72.20 YR/L	7,2	30,5	0,2	81
A07.1835.35.72.20 YR/L	7,2	35,6	0,2	81
A07.1835.40.72.20 YR/L	7,2	40,6	0,2	81
A07.1835.45.72.20 YR/L	7,2	45,7	0,2	81
A07.1835.50.72.20 YR/L	7,2	50,8	0,2	81
A07.1835.60.72.20 YR	7,2	60,8	0,2	81

Ausdrehen

Geeignet ab Bohrungsdurchmesser 0,3 mm.

Boring

For use in bores as of minimum bore diameter 0,3 mm.

Schnittwerte (Start) // Cutting parameters (start)

f	Vc
0,02 mm/U	Seite/Page 429

Passende Klemmhalter auf Seite // Suitable toolholders on page

26, 31, 32, 33, 34, 40, 41, 43, 50,
51, 53, 55, 56, 57, 60, 62, 63, 65,
66, 67, 68, 69

Vergleichbare Werkzeuge auf Seite // Similar tools on page

70



SP **HM** **R** Legende Legend **139**
Scan QR-Code Oder besuchen Sie // Or Visit www.simtek.info/cp/1043

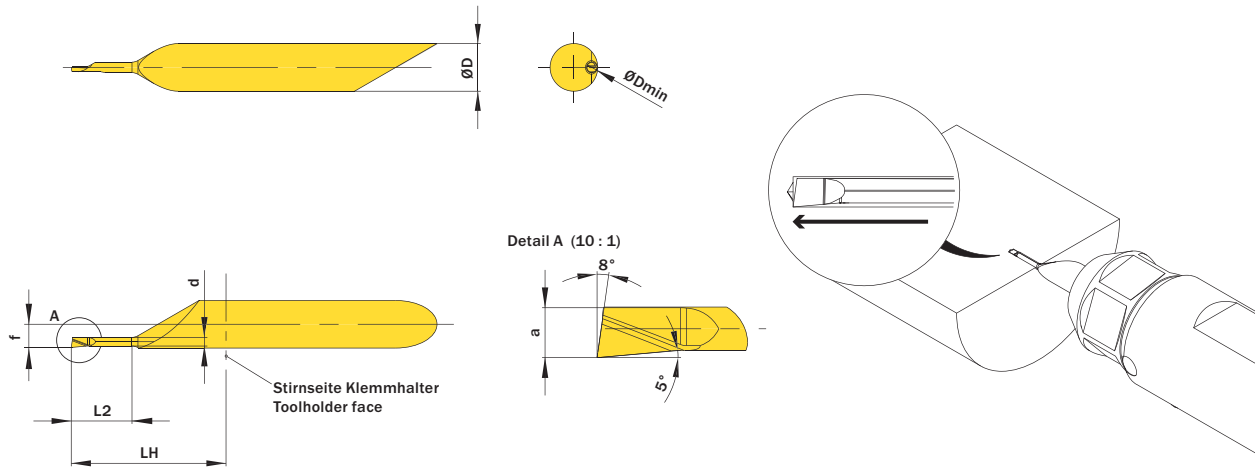


Abbildung zeigt / Drawing shows: A04.5C45.05.09.00 Y R

Mehr Informationen zur Kühlmittelzufuhr finden Sie auf Seite 22
Additional information about through coolant supply on page 22

ØD	L2	ØDmin (Min. Bohrung) ØDmin (min. bore)	R	Kühlmittelzufuhr Through coolant supply	Artikelnummer Part number	Webcode www.simtek.com/webcode	Unsere erste Wahl Our first choice	a	d	f	LH	Connectcode www.simtek.com/code
mm	mm	mm	mm				P K M N S	mm	mm	mm	mm	
▼ ØDmin (Min. Bohrung) // ØDmin (min. bore) = 0,3 mm												
4,0	1,2	0,3	-	-	A04.5015.01.03.00 YR/L	R AMZP L ANTU	X800 X400	0,25	0,19	0,1	13,0	R A04.R L A04.L
4,0	1,2	0,3	-	+	A04.5C15.01.03.00 YR/L	R AW9E L AW99	X800 X400	0,25	0,19	1,95	13,0	R A04C.R L A04C.L
▼ ØDmin (Min. Bohrung) // ØDmin (min. bore) = 0,4 mm												
4,0	1,6	0,4	-	-	A04.5020.01.04.00 YR/L	R AHJV L AFUM	X800 X400	0,35	0,28	0,15	13,0	R A04.R L A04.L
4,0	1,6	0,4	-	+	A04.5C20.01.04.00 YR/L	R AW9F L AXAA	X800 X400	0,35	0,28	1,95	13,0	R A04C.R L A04C.L
▼ ØDmin (Min. Bohrung) // ØDmin (min. bore) = 0,5 mm												
4,0	2,0	0,5	-	-	A04.5025.02.05.00 YR/L	R AASX L AK4W	X800 X400	0,45	0,37	0,2	13,0	R A04.R L A04.L
4,0	2,0	0,5	-	+	A04.5C25.02.05.00 YR/L	R ABJW L ABH9	X800 X400	0,45	0,37	1,95	13,0	R A04C.R L A04C.L
▼ ØDmin (Min. Bohrung) // ØDmin (min. bore) = 0,6 mm												
4,0	2,5	0,6	-	-	A04.5030.02.06.00 YR/L	R APAZ L AH1C	X800 X400	0,55	0,46	0,25	13,0	R A04.R L A04.L
4,0	2,5	0,6	-	+	A04.5C30.02.06.00 YR/L	R APVN L ANA8	X800 X400	0,55	0,46	1,95	13,0	R A04C.R L A04C.L
▼ ØDmin (Min. Bohrung) // ØDmin (min. bore) = 0,7 mm												
4,0	3,6	0,7	-	-	A04.5035.03.07.00 YR/L	R AP2U L ADPH	X800 X400	0,65	0,55	0,3	13,0	R A04.R L A04.L
4,0	3,6	0,7	-	+	A04.5C35.03.07.00 YR/L	R AB9W L AEYB	X800 X400	0,65	0,55	1,95	13,0	R A04C.R L A04C.L
▼ ØDmin (Min. Bohrung) // ØDmin (min. bore) = 0,8 mm												
4,0	4,1	0,8	-	-	A04.5040.04.08.00 YR/L	R AJ56 L AHP9	X800 X400	0,75	0,64	0,35	13,0	R A04.R L A04.L
4,0	4,1	0,8	-	+	A04.5C40.04.08.00 YR/L	R AJ4N L AEWY	X800 X400	0,75	0,64	1,95	13,0	R A04C.R L A04C.L
▼ ØDmin (Min. Bohrung) // ØDmin (min. bore) = 0,9 mm												
4,0	5,1	0,9	-	-	A04.5045.05.09.00 YR/L	R ANØX L ACN2	X800 X400	0,85	0,73	0,4	13,0	R A04.R L A04.L
4,0	5,1	0,9	-	+	A04.5C45.05.09.00 YR/L	R ADKP L AMVH	X800 X400	0,85	0,73	1,95	13,0	R A04C.R L A04C.L

Verwandte Werkzeuge finden Sie auch auf der folgenden Seite!
Related Items can be found on the following page as well!

Fortgesetzte Tabelle
Continued Table

Bestellbeispiel // Order example: A04.5015.01.03.00 YR X800 (R = Rechte Ausführung // Right hand version, X800 = Schneidstoff // Grade)

Ausdrehen

Geeignet ab Bohrungsdurchmesser 1,0 mm.

Boring

For use in bores as of minimum bore diameter 1,0 mm.

Schnittwerte (Start) // Cutting parameters (start)

f	Vc
0,02 mm/U	Seite/Page 429

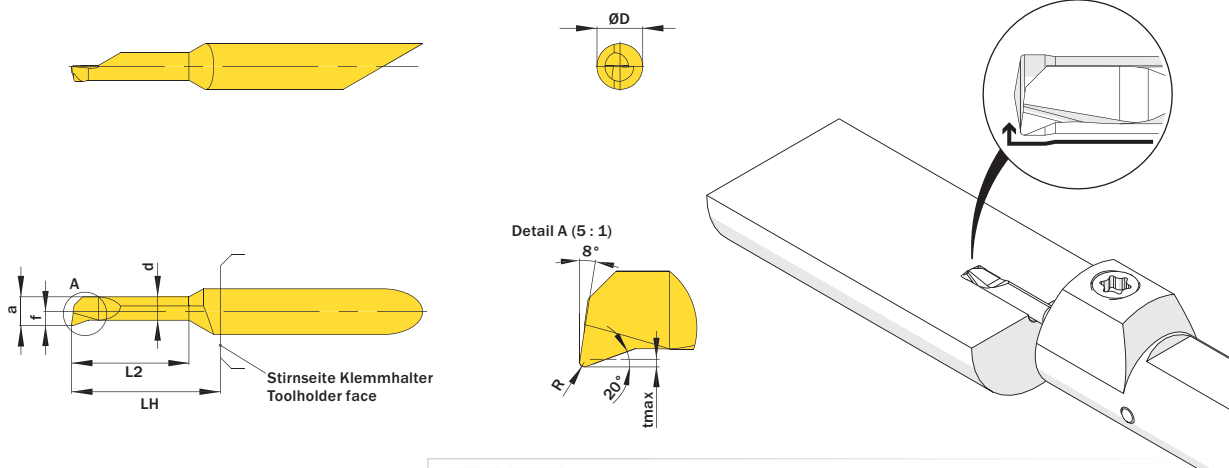
Passende Klemmhalter auf Seite // Suitable toolholders on page

26, 31, 32, 33, 34, 40, 41, 43, 50,
51, 53, 55, 56, 57, 60, 62, 63, 65,
66, 67, 68, 69

Vergleichbare Werkzeuge auf Seite // Similar tools on page

70

Scan QR-Code Oder besuchen Sie // Or Visit www.simtek.info/cp/1044



Mehr Informationen zur Kühlmittelzufuhr finden Sie auf Seite 22
Additional information about through coolant supply on page 22

ØD	L2	ØDmin (Min. Bohrung) ØDmin (min. bore)	R	Kühlmittelzufuhr Through coolant supply	Artikelnummer Part number	Webcode www.simtek.com/webcode	Unsere erste Wahl Our first choice	a	d	f	LH	tmax	Connectcode www.simtek.com/code
mm	mm	mm	mm				P K M N S	mm	mm	mm	mm	mm	

Fortgesetzte Tabelle // Continued Table
Verwandte Werkzeuge finden Sie auch auf der vorhergehenden Seite!
Related Items can be found on the previous page as well!

▼ ØDmin (Min. Bohrung) // ØDmin (min. bore) = 1,0 mm													
4,0	4,1	1,0	0,05	-	A04.1804.04.10.05 YR/L	R AMGN L AK3Z	X800 X400	0,95	0,65	0,45	13,0	0,1	R A04.R L A04.L
4,0	4,1	1,0	0,05	+	A04.1C04.04.10.05 YR/L	R AW9G L AXAB	X800 X400	0,95	0,65	1,95	13,0	0,1	R A04C.R L A04C.L
4,0	4,1	1,0	0,1	-	A04.1804.04.10.10 YR/L	R AH77 L ADKJ	X800 X400	0,95	0,65	0,45	13,0	0,1	R A04.R L A04.L
4,0	4,1	1,0	0,1	+	A04.1C04.04.10.10 YR/L	R AHJJ L AFJE	X800 X400	0,95	0,65	1,95	13,0	0,1	R A04C.R L A04C.L
4,0	6,1	1,0	0,05	-	A04.1804.06.10.05 YR/L	R AHGX L APQV	X800 X400	0,95	0,65	0,45	13,0	0,1	R A04.R L A04.L
4,0	6,1	1,0	0,05	+	A04.1C04.06.10.05 YR/L	R AW9H L AXAC	X800 X400	0,95	0,65	1,95	13,0	0,1	R A04C.R L A04C.L
4,0	6,1	1,0	0,1	-	A04.1804.06.10.10 YR/L	R ADN1 L AASJ	X800 X400	0,95	0,65	0,45	13,0	0,1	R A04.R L A04.L
4,0	6,1	1,0	0,1	+	A04.1C04.06.10.10 YR/L	R AJGF L AMNZ	X800 X400	0,95	0,65	1,95	13,0	0,1	R A04C.R L A04C.L
4,0	8,1	1,0	0,1	-	A04.1804.08.10.10 YR/L	R AJHB L AEXS	X800 X400	0,95	0,65	0,45	13,0	0,1	R A04.R L A04.L
4,0	8,1	1,0	0,1	+	A04.1C04.08.10.10 YR/L	R ANWW L AJEK	X800 X400	0,95	0,65	1,95	13,0	0,1	R A04C.R L A04C.L
▼ ØDmin (Min. Bohrung) // ØDmin (min. bore) = 1,2 mm													
4,0	5,1	1,2	0,1	-	A04.1805.04.12.10 YR/L	R A517 L A519	X800 X400	1,1	0,8	0,55	13,0	0,1	R A04.R L A04.L new
4,0	5,1	1,2	0,1	+	A04.1C05.04.12.10 YR/L	R AW3A L AW29	X800 X400	1,1	0,8	1,95	13,0	0,1	R A04C.R L A04C.L
4,0	7,1	1,2	0,1	-	A04.1805.07.12.10 YR/L	R A52D L A52B	X800 X400	1,1	0,8	0,55	13,0	0,1	R A04.R L A04.L new
4,0	7,1	1,2	0,1	+	A04.1C05.07.12.10 YR/L	R AW3C L AW3B	X800 X400	1,1	0,8	1,95	13,0	0,1	R A04C.R L A04C.L
4,0	9,1	1,2	0,1	-	A04.1805.09.12.10 YR/L	R A52K L A52F	X800 X400	1,1	0,8	0,55	13,0	0,1	R A04.R L A04.L new
4,0	9,1	1,2	0,1	+	A04.1C05.09.12.10 YR/L	R AW3E L AW3D	X800 X400	1,1	0,8	1,95	13,0	0,1	R A04C.R L A04C.L
▼ ØDmin (Min. Bohrung) // ØDmin (min. bore) = 1,4 mm													
4,0	6,1	1,4	0,1	-	A04.1806.06.14.10 YR/L	R A52Q L A52N	X800 X400	1,25	0,9	0,6	13,0	0,15	R A04.R L A04.L new
4,0	6,1	1,4	0,1	+	A04.1C06.06.14.10 YR/L	R AW3G L AW3F	X800 X400	1,25	0,9	1,95	13,0	0,15	R A04C.R L A04C.L
4,0	10,2	1,4	0,1	-	A04.1806.10.14.10 YR/L	R A52V L A52T	X800 X400	1,25	0,9	0,6	13,0	0,15	R A04.R L A04.L new
4,0	10,2	1,4	0,1	+	A04.1C06.10.14.10 YR/L	R AW3J L AW3H	X800 X400	1,25	0,9	1,95	13,0	0,15	R A04C.R L A04C.L

Verwandte Werkzeuge finden Sie auch auf der folgenden Seite!
Related Items can be found on the following page as well!

Fortgesetzte Tabelle
Continued Table

Bestellbeispiel // Order example: A04.1804.04.10.10 YR X800 (R = Rechte Ausführung // Right hand version, X800 = Schneidstoff // Grade)

Ausdrehen

Geeignet ab Bohrungsdurchmesser 1,7 mm.

Boring

For use in bores as of minimum bore diameter 1,7 mm.

Schnittwerte (Start) // Cutting parameters (start)	
f 0,02 mm/U	Vc Seite/Page 429

Passende Klemmhalter auf Seite // Suitable toolholders on page
26, 31, 32, 33, 34, 40, 41, 43, 50, 51, 53, 55, 56, 57, 60, 62, 63, 65, 66, 67, 68, 69

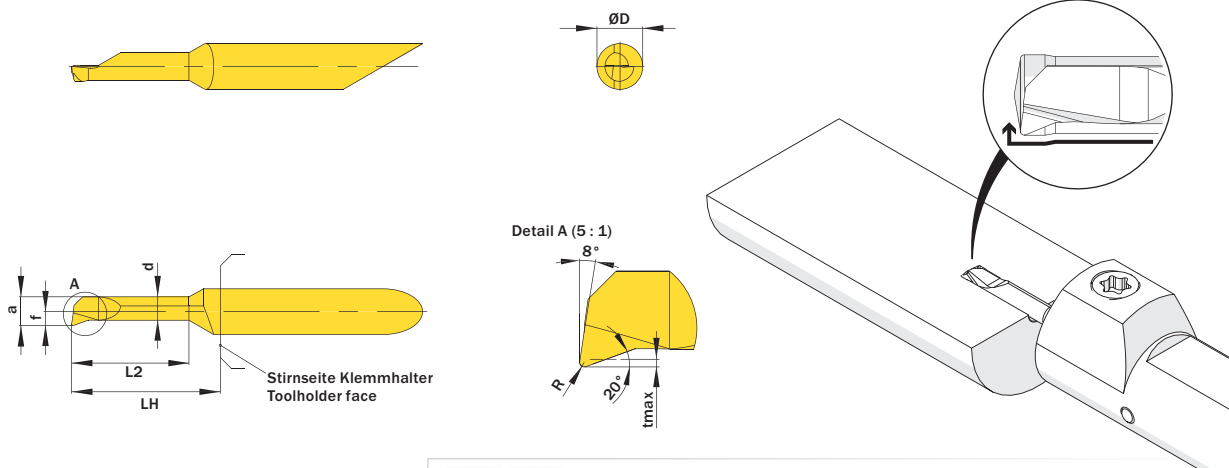
Vergleichbare Werkzeuge auf Seite // Similar tools on page
70

SP
HM
R

Legende
Legend **139**

Scan
QR-Code

Oder besuchen Sie // Or Visit
www.simtek.info/cp/1054



Mehr Informationen zur Kühlmittelzufuhr finden Sie auf Seite 22
Additional information about through coolant supply on page 22

ØD	L2	ØDmin (Min. Bohrung) ØDmin (min. bore)	R	Kühlmittelzufuhr Through coolant supply	Artikelnummer Part number	Webcode www.simtek.com/webcode	Unsere erste Wahl Our first choice	a	d	f	LH	tmax	Connectcode www.simtek.com/code
mm	mm	mm	mm				P K M N S	mm	mm	mm	mm	mm	

Fortgesetzte Tabelle Continued Table **Verwandte Werkzeuge finden Sie auch auf der vorhergehenden Seite!**
Related items can be found on the previous page as well!

▼ ØDmin (Min. Bohrung) // ØDmin (min. bore) = 1,7 mm														
4,0	6,1	1,7	0,05	-	A04.1807.06.17.05 YR/L	R ABA5	L ADK9	X800 X400	1,45	1,05	0,7	13,0	0,2	R A04.R L A04.L
4,0	6,1	1,7	0,05	+	A04.1C07.06.17.05 YR/L	R AW9J	L AXAD	X800 X400	1,45	1,05	1,95	13,0	0,2	R A04C.R L A04C.L
4,0	6,1	1,7	0,1	-	A04.1807.06.17.10 YR/L	R AEAZ	L APEV	X800 X400	1,45	1,05	0,7	13,0	0,2	R A04.R L A04.L
4,0	6,1	1,7	0,1	+	A04.1C07.06.17.10 YR/L	R AF0J	L ANPT	X800 X400	1,45	1,05	1,95	13,0	0,2	R A04C.R L A04C.L
4,0	9,1	1,7	0,05	-	A04.1807.09.17.05 YR/L	R AEHK	L AJZB	X800 X400	1,45	1,05	0,7	13,0	0,2	R A04.R L A04.L
4,0	9,1	1,7	0,05	+	A04.1C07.09.17.05 YR/L	R AW9K	L AXAE	X800 X400	1,45	1,05	1,95	13,0	0,2	R A04C.R L A04C.L
4,0	9,1	1,7	0,1	-	A04.1807.09.17.10 YR/L	R AD7Q	L AGHY	X800 X400	1,45	1,05	0,7	13,0	0,2	R A04.R L A04.L
4,0	9,1	1,7	0,1	+	A04.1C07.09.17.10 YR/L	R ANYC	L AKAA	X800 X400	1,45	1,05	1,95	13,0	0,2	R A04C.R L A04C.L
4,0	12,2	1,7	0,1	-	A04.1807.12.17.10 YR/L	R A53F	L A53D	X800 X400	1,45	1,05	0,7	18,0	0,2	R A04.R L A04.L new
4,0	12,2	1,7	0,1	+	A04.1C07.12.17.10 YR/L	R A199	L A53B	X800 X400	1,45	1,05	1,95	18,0	0,2	R A04C.R L A04C.L new
▼ ØDmin (Min. Bohrung) // ØDmin (min. bore) = 1,9 mm														
4,0	9,1	1,9	0,1	-	A04.1808.09.19.10 YR/L	R A52Z	L A52X	X800 X400	1,65	1,25	0,85	13,0	0,2	R A04.R L A04.L new
4,0	9,1	1,9	0,1	+	A04.1C08.09.19.10 YR/L	R AW3M	L AW3K	X800 X400	1,65	1,25	1,95	13,0	0,2	R A04C.R L A04C.L
4,0	12,2	1,9	0,1	-	A04.1808.12.19.10 YR/L	R A523	L A521	X800 X400	1,65	1,25	0,85	18,0	0,2	R A04.R L A04.L new
4,0	12,2	1,9	0,1	+	A04.1C08.12.19.10 YR/L	R AW3P	L AW3N	X800 X400	1,65	1,25	1,95	18,0	0,2	R A04C.R L A04C.L
4,0	13,2	1,9	0,1	-	A04.1808.13.19.10 YR/L	R A529	L A527	X800 X400	1,65	1,25	0,85	18,0	0,2	R A04.R L A04.L new
4,0	13,2	1,9	0,1	+	A04.1C08.13.19.10 YR/L	R A2AA	L A525	X800 X400	1,65	1,25	1,95	18,0	0,2	R A04C.R L A04C.L new

Verwandte Werkzeuge finden Sie auch auf der folgenden Seite!
Related items can be found on the following page as well!

Fortgesetzte Tabelle Continued Table

Bestellbeispiel // Order example: **A04.1807.06.17.10 YR X800** (R = Rechte Ausführung // Right hand version, X800 = Schneidstoff // Grade)

Ausdrehen

Geeignet ab Bohrungsdurchmesser 2,2 mm.

Boring

For use in bores as of minimum bore diameter 2,2 mm.

Schnittwerte (Start) // Cutting parameters (start)

f	Vc
0,02 mm/U	Seite/Page 429

Passende Klemmhalter auf Seite // Suitable toolholders on page

26, 31, 32, 33, 34, 40, 41, 43, 50,
51, 53, 55, 56, 57, 60, 62, 63, 65,
66, 67, 68, 69

Vergleichbare Werkzeuge auf Seite // Similar tools on page

70

SP

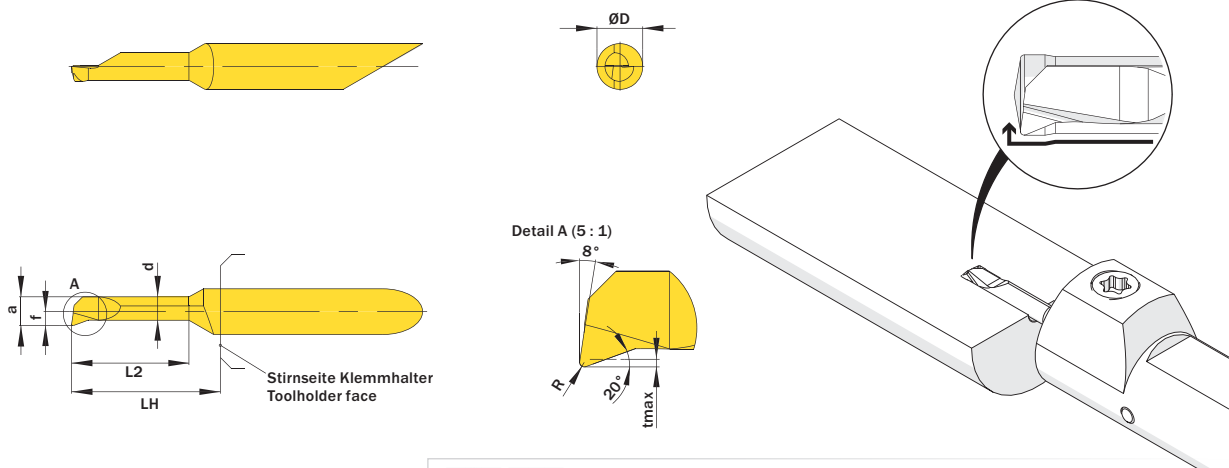
HM

R

Legende
Legend **139**

Scan
QR-Code

Oder besuchen Sie // Or Visit
www.simtek.info/cp/1038



Mehr Informationen zur Kühlmittelzufuhr finden Sie auf Seite 22
Additional information about through coolant supply on page 22

ØD	L2	ØDmin (Min. Bohrung) ØDmin (min. bore)	R	Kühlmittelzufuhr Through coolant supply	Artikelnummer Part number	Webcode www.simtek.com/webcode	Unsere erste Wahl Our first choice	a	d	f	LH	tmax	Connectcode www.simtek.com/code
mm	mm	mm	mm				P K M N S	mm	mm	mm	mm	mm	

◀ Fortgesetzte Tabelle
Continued Table

Verwandte Werkzeuge finden Sie auch auf der vorhergehenden Seite!
Related Items can be found on the previous page as well!

4,0	6,1	2,2	0,05	●	A04.1810.06.22.05 YR/L	R AEWA L AHNE	X800 X400	1,95	1,55	0,95	13,0	0,2	R	A04.R	L	A04.L
4,0	6,1	2,2	0,05	+	A04.1C10.06.22.05 YR/L	R AW9M L AXAF	X800 X400	1,95	1,55	1,95	13,0	0,2	R	A04.C.R	L	A04.C.L
4,0	6,1	2,2	0,1	●	A04.1810.06.22.10 YR/L	R AMKG L ABK2	X800 X400	1,95	1,55	0,95	13,0	0,2	R	A04.R	L	A04.L
4,0	6,1	2,2	0,1	+	A04.1C10.06.22.10 YR/L	R ABCM L AKQQ	X800 X400	1,95	1,55	1,95	13,0	0,2	R	A04.C.R	L	A04.C.L
4,0	9,1	2,2	0,05	●	A04.1810.09.22.05 YR/L	R AFEA L AEVE	X800 X400	1,95	1,55	0,95	13,0	0,2	R	A04.R	L	A04.L
4,0	9,1	2,2	0,05	+	A04.1C10.09.22.05 YR/L	R AW9N L AXAG	X800 X400	1,95	1,55	1,95	13,0	0,2	R	A04.C.R	L	A04.C.L
4,0	9,1	2,2	0,1	●	A04.1810.09.22.10 YR/L	R AM4S L AA7F	X800 X400	1,95	1,55	0,95	13,0	0,2	R	A04.R	L	A04.L
4,0	9,1	2,2	0,1	+	A04.1C10.09.22.10 YR/L	R ABD9 L AMX3	X800 X400	1,95	1,55	1,95	13,0	0,2	R	A04.C.R	L	A04.C.L
4,0	13,2	2,2	0,1	●	A04.1810.13.22.10 YR/L	R AKP9 L AJ36	X800 X400	1,95	1,55	0,95	18,0	0,2	R	A04.R	L	A04.L
4,0	13,2	2,2	0,1	+	A04.1C10.13.22.10 YR/L	R AGGH L AEBZ	X800 X400	1,95	1,55	1,95	18,0	0,2	R	A04.C.R	L	A04.C.L
4,0	15,2	2,2	0,1	+	A04.1C10.15.22.10 YR	A2AB	X800 X400	1,95	1,55	1,95	23,0	0,2				A04.C.R
▼ ØDmin (Min. Bohrung) // ØDmin (min. bore) = 2,7 mm																
4,0	10,2	2,7	0,03	●	A04.1812.10.27.03 YR/L	R AKG6 L AHF1	X800 X400	2,45	2,05	1,2	13,0	0,2	R	A04.R	L	A04.L
4,0	10,2	2,7	0,03	+	A04.1C12.10.27.03 YR/L	R AW9P L AXAH	X800 X400	2,45	2,05	1,95	13,0	0,2	R	A04.C.R	L	A04.C.L
4,0	10,2	2,7	0,05	●	A04.1812.10.27.05 YR/L	R AFXD L AFVH	X800 X400	2,45	2,05	1,2	13,0	0,2	R	A04.R	L	A04.L
4,0	10,2	2,7	0,05	+	A04.1C12.10.27.05 YR/L	R AW9Q L AXAJ	X800 X400	2,45	2,05	1,95	13,0	0,2	R	A04.C.R	L	A04.C.L
4,0	10,2	2,7	0,15	●	A04.1812.10.27.15 YR/L	R AH2M L ACX1	X800 X400	2,45	2,05	1,2	13,0	0,2	R	A04.R	L	A04.L
4,0	10,2	2,7	0,15	+	A04.1C12.10.27.15 YR/L	R AJ8J L AJ01	X800 X400	2,45	2,05	1,95	13,0	0,2	R	A04.C.R	L	A04.C.L
4,0	15,2	2,7	0,05	●	A04.1812.15.27.05 YR/L	R ANPQ L AEK2	X800 X400	2,45	2,05	1,2	18,0	0,2	R	A04.R	L	A04.L
4,0	15,2	2,7	0,05	+	A04.1C12.15.27.05 YR/L	R AW9S L AXAK	X800 X400	2,45	2,05	1,95	18,0	0,2	R	A04.C.R	L	A04.C.L
4,0	15,2	2,7	0,15	●	A04.1812.15.27.15 YR/L	R AA95 L AJKP	X800 X400	2,45	2,05	1,2	18,0	0,2	R	A04.R	L	A04.L
4,0	15,2	2,7	0,15	+	A04.1C12.15.27.15 YR/L	R AB8C L AAQ1	X800 X400	2,45	2,05	1,95	18,0	0,2	R	A04.C.R	L	A04.C.L
4,0	20,3	2,7	0,15	+	A04.1C12.20.27.15 YR	A2AC	X800 X400	2,45	2,05	1,95	28,0	0,2				A04.C.R

Verwandte Werkzeuge finden Sie auch auf der folgenden Seite!
Related Items can be found on the following page as well!

Fortgesetzte Tabelle
Continued Table ▶

Bestellbeispiel // Order example: **A04.1812.10.27.15 YR X800** (R = Rechte Ausführung // Right hand version, X800 = Schneidstoff // Grade)

Ausdrehen

Geeignet ab Bohrungsdurchmesser 3,0 mm.

Boring

For use in bores as of minimum bore diameter 3,0 mm.

Schnittwerte (Start) // Cutting parameters (start)

f	Vc
0,02 mm/U	Seite/Page 429

Passende Klemmhalter auf Seite // Suitable toolholders on page

26, 31, 32, 33, 34, 40, 41, 43, 50,
51, 53, 55, 56, 57, 60, 62, 63, 65,
66, 67, 68, 69

Vergleichbare Werkzeuge auf Seite // Similar tools on page

70

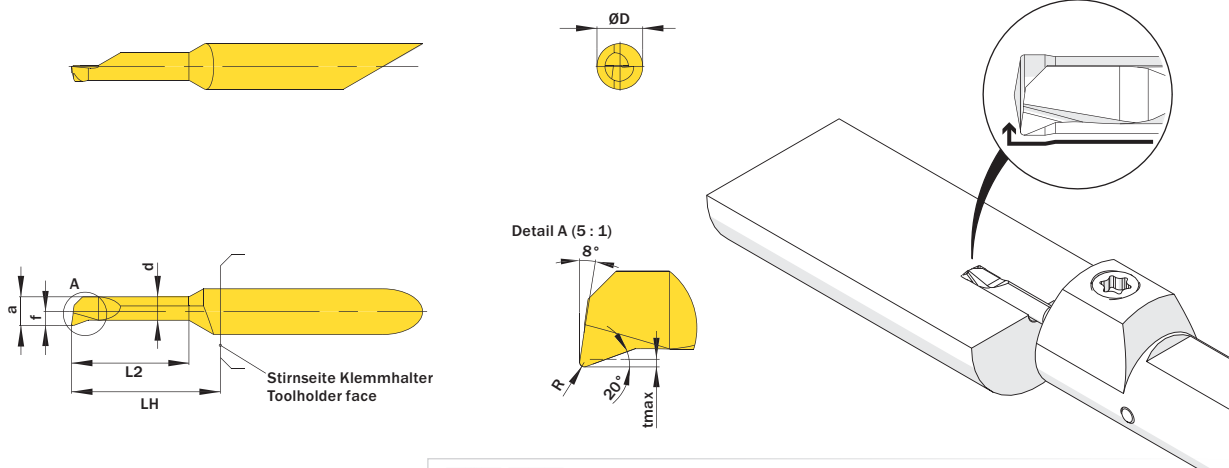
SP

HM

R

Legende
Legend **139**

Scan QR-Code Oder besuchen Sie // Or Visit
www.simtek.info/cp/1039



Mehr Informationen zur Kühlmittelzufuhr finden Sie auf Seite 22
Additional information about through coolant supply on page 22

ØD	L2	ØDmin (Min. Bohrung) ØDmin (min. bore)	R	Kühlmittelzufuhr Through coolant supply	Artikelnummer Part number	Webcode www.simtek.com/webcode	Unsere erste Wahl Our first choice	a	d	f	LH	tmax	Connectcode www.simtek.com/code
mm	mm	mm	mm				P K M N S	mm	mm	mm	mm	mm	

Fortgesetzte Tabelle
Continued Table

Verwandte Werkzeuge finden Sie auch auf der vorhergehenden Seite!
Related Items can be found on the previous page as well!

▼ ØDmin (Min. Bohrung) // ØDmin (min. bore) = 3,0 mm													
4,0	15,2	3,0	0,15	+	A04.1C14.15.30.15 YR/L	R AW3S L AW3Q	X800 X400	2,75	2,35	1,95	18,0	0,2	R A04C.R L A04C.L
4,0	20,3	3,0	0,15	•	A04.1814.20.30.15 YR/L	R APP5 L AMU6	X800 X400	2,75	2,35	1,35	23,0	0,2	R A04.R L A04.L
4,0	20,3	3,0	0,15	+	A04.1C14.20.30.15 YR/L	R AHQ2 L AKT4	X800 X400	2,75	2,35	1,95	23,0	0,2	R A04C.R L A04C.L
4,0	25,4	3,0	0,05	•	A04.1814.25.30.05 YR/L	R ATVX L AVEY	X800 X400	2,75	2,35	1,35	28,0	0,2	R A04.R L A04.L
4,0	25,4	3,0	0,05	+	A04.1C14.25.30.05 YR/L	R AW9T L AXAM	X800 X400	2,75	2,35	1,95	28,0	0,2	R A04C.R L A04C.L
▼ ØDmin (Min. Bohrung) // ØDmin (min. bore) = 3,2 mm													
4,0	10,2	3,2	0,03	•	A04.1815.10.32.03 YR/L	R AM5F L AH7Q	X800 X400	2,95	2,55	1,45	13,0	0,2	R A04.R L A04.L
4,0	10,2	3,2	0,03	+	A04.1C15.10.32.03 YR/L	R AW9V L AXAP	X800 X400	2,95	2,55	1,95	13,0	0,2	R A04C.R L A04C.L
4,0	10,2	3,2	0,05	•	A04.1815.10.32.05 YR/L	R ACMP L AMPB	X800 X400	2,95	2,55	1,45	13,0	0,2	R A04.R L A04.L
4,0	10,2	3,2	0,05	+	A04.1C15.10.32.05 YR/L	R AW9W L AXAQ	X800 X400	2,95	2,55	1,95	13,0	0,2	R A04C.R L A04C.L
4,0	10,2	3,2	0,15	•	A04.1815.10.32.15 YR/L	R ANAV L AKDJ	X800 X400	2,95	2,55	1,45	13,0	0,2	R A04.R L A04.L
4,0	10,2	3,2	0,15	+	A04.1C15.10.32.15 YR/L	R AG17 L AC37	X800 X400	2,95	2,55	1,95	13,0	0,2	R A04C.R L A04C.L
4,0	15,2	3,2	0,05	•	A04.1815.15.32.05 YR/L	R AHFZ L AAS8	X800 X400	2,95	2,55	1,45	18,0	0,2	R A04.R L A04.L
4,0	15,2	3,2	0,05	+	A04.1C15.15.32.05 YR/L	R AW9X L AXAS	X800 X400	2,95	2,55	1,95	18,0	0,2	R A04C.R L A04C.L
4,0	15,2	3,2	0,15	•	A04.1815.15.32.15 YR/L	R APP9 L AFN6	X800 X400	2,95	2,55	1,45	18,0	0,2	R A04.R L A04.L
4,0	15,2	3,2	0,15	+	A04.1C15.15.32.15 YR/L	R ABTG L AAW9	X800 X400	2,95	2,55	1,95	18,0	0,2	R A04C.R L A04C.L
4,0	20,3	3,2	0,05	•	A04.1815.20.32.05 YR/L	R APGP L AFHA	X800 X400	2,95	2,55	1,45	23,0	0,2	R A04.R L A04.L
4,0	20,3	3,2	0,05	+	A04.1C15.20.32.05 YR/L	R AW9Y L AXAT	X800 X400	2,95	2,55	1,95	23,0	0,2	R A04C.R L A04C.L
4,0	20,3	3,2	0,15	•	A04.1815.20.32.15 YR/L	R AQCT L ABZB	X800 X400	2,95	2,55	1,45	23,0	0,2	R A04.R L A04.L
4,0	20,3	3,2	0,15	+	A04.1C15.20.32.15 YR/L	R AAVU L ADEU	X800 X400	2,95	2,55	1,95	23,0	0,2	R A04C.R L A04C.L
4,0	25,4	3,2	0,15	+	A04.1C15.25.32.15 YR	A2AD	X800 X400	2,95	2,55	1,95	28,0	0,2	A04C.R

Verwandte Werkzeuge finden Sie auch auf der folgenden Seite!
Related Items can be found on the following page as well!

Fortgesetzte Tabelle
Continued Table

Bestellbeispiel // Order example: A04.1815.10.32.15 YR X800 (R = Rechte Ausführung // Right hand version, X800 = Schneidstoff // Grade)

Ausdrehen

Geeignet ab Bohrungsdurchmesser 3,7 mm.

Boring

For use in bores as of minimum bore diameter 3,7 mm.

Schnittwerte (Start) // Cutting parameters (start)

f	Vc
0,02 mm/U	Seite/Page 429

Passende Klemmhalter auf Seite // Suitable toolholders on page

26, 31, 32, 33, 34, 40, 41, 43, 50,
51, 53, 55, 56, 57, 60, 62, 63, 65,
66, 67, 68, 69

Vergleichbare Werkzeuge auf Seite // Similar tools on page

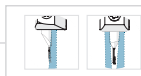
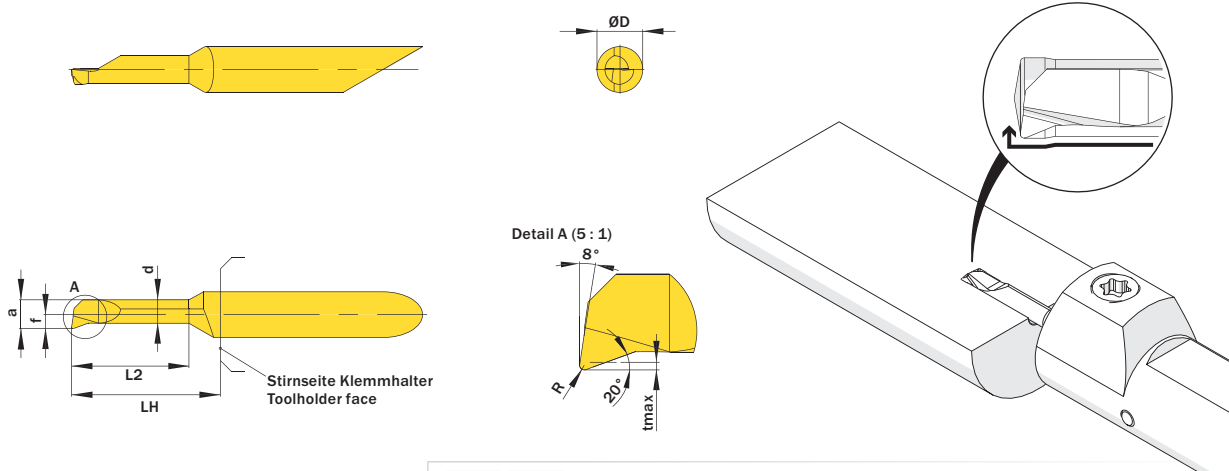
70



Legende
Legend 139



Scan QR-Code
Oder besuchen Sie // Or Visit
www.simtek.info/cp/1055



Mehr Informationen zur Kühlmittelzufuhr finden Sie auf Seite 22
Additional information about through coolant supply on page 22

ØD	L2	ØDmin (Min. Bohrung) ØDmin (min. bore)	R	Kühlmittelzufuhr Through coolant supply	Artikelnummer Part number	Webcode www.simtek.com/webcode	Unsere erste Wahl Our first choice	a	d	f	LH	tmax	Connectcode www.simtek.com/code
mm	mm	mm	mm				P K M N S	mm	mm	mm	mm	mm	

Fortgesetzte Tabelle Continued Table
Verwandte Werkzeuge finden Sie auch auf der vorhergehenden Seite!
Related Items can be found on the previous page as well!

4,0	10,2	3,7	0,15	●	A04.1817.10.37.15 YR/L	R AHD4 L AMYK	X800 X400	3,45	3,05	1,7	13,0	0,2	R A04.R L A04.L
4,0	10,2	3,7	0,15	+	A04.1C17.10.37.15 YR/L	R ANJF L ANZP	X800 X400	3,45	3,05	1,95	13,0	0,2	R A04C.R L A04C.L
4,0	15,2	3,7	0,15	●	A04.1817.15.37.15 YR/L	R AMQN L ABA7	X800 X400	3,45	3,05	1,7	18,0	0,2	R A04.R L A04.L
4,0	15,2	3,7	0,15	+	A04.1C17.15.37.15 YR/L	R AHBD L APYD	X800 X400	3,45	3,05	1,95	18,0	0,2	R A04C.R L A04C.L
4,0	20,3	3,7	0,05	●	A04.1817.20.37.05 YR/L	R AQ1U L AQ1V	X800 X400	3,45	3,05	1,7	23,0	0,2	R A04.R L A04.L
4,0	20,3	3,7	0,05	+	A04.1C17.20.37.05 YR/L	R AW9U L AXAN	X800 X400	3,45	3,05	1,95	23,0	0,2	R A04C.R L A04C.L
4,0	20,3	3,7	0,15	●	A04.1817.20.37.15 YR/L	R AKNZ L AH9Y	X800 X400	3,45	3,05	1,7	23,0	0,2	R A04.R L A04.L
4,0	20,3	3,7	0,15	+	A04.1C17.20.37.15 YR/L	R AB5S L AFAA	X800 X400	3,45	3,05	1,95	23,0	0,2	R A04C.R L A04C.L
4,0	25,4	3,7	0,1	●	A04.1817.25.37.10 YR/L	R AA9M L ADKH	X800 X400	3,45	3,05	1,7	28,0	0,2	R A04.R L A04.L
4,0	25,4	3,7	0,1	+	A04.1C17.25.37.10 YR/L	R ANNS L AEFW	X800 X400	3,45	3,05	1,95	28,0	0,2	R A04C.R L A04C.L
4,0	30,5	3,7	0,1	+	A04.1C17.30.37.10 YR	R A2AE	X800 X400	3,45	3,05	1,95	33,0	0,2	A04C.R

Verwandte Werkzeuge finden Sie auch auf der folgenden Seite!
Related Items can be found on the following page as well!

Fortgesetzte Tabelle Continued Table

Bestellbeispiel // Order example: A04.1817.15.37.15 YR X800 (R = Rechte Ausführung // Right hand version, X800 = Schneidstoff // Grade)

Ausdrehen

Geeignet ab Bohrungsdurchmesser 4,2 mm.

Boring

For use in bores as of minimum bore diameter 4,2 mm.

Schnittwerte (Start) // Cutting parameters (start)

f	Vc
0,02 mm/U	Seite/Page 429

Passende Klemmhalter auf Seite // Suitable toolholders on page

31, 32, 34, 40, 41, 43, 50, 51, 53, 55, 56, 57, 60, 62, 63, 66, 67, 68, 69

Vergleichbare Werkzeuge auf Seite // Similar tools on page

70

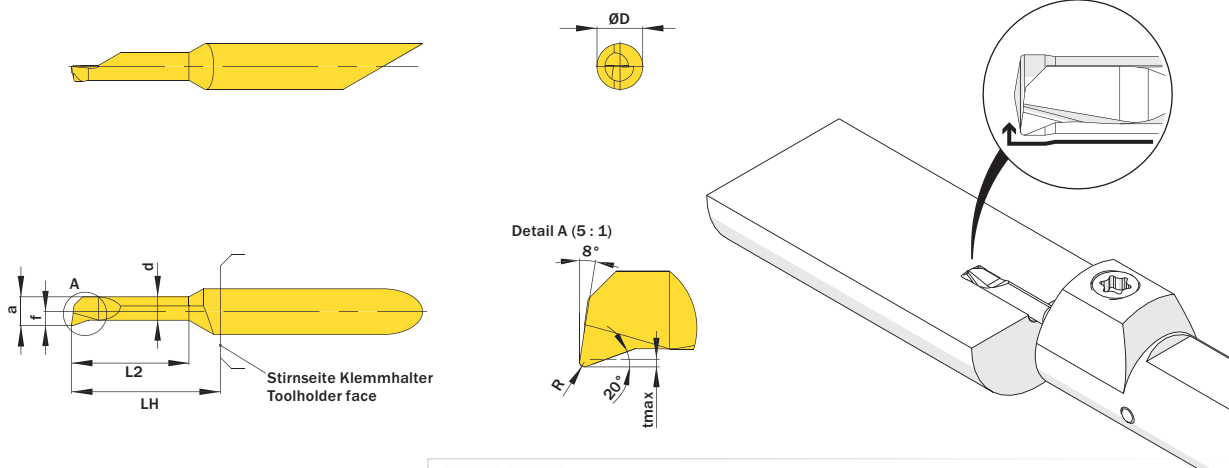
SP

HM

R

Legende
Legend **139**

Scan QR-Code Oder besuchen Sie // Or Visit
www.simtek.info/cp/1040



Mehr Informationen zur Kühlmittelzufuhr finden Sie auf Seite 22
Additional information about through coolant supply on page 22

ØD	L2	ØDmin (Min. Bohrung) ØDmin (min. bore)	R	Kühlmittelzufuhr Through coolant supply	Artikelnummer Part number	Webcode www.simtek.com/webcode	Unsere erste Wahl Our first choice	a	d	f	LH	tmax	Connectcode www.simtek.com/code
mm	mm	mm	mm				P K M N S	mm	mm	mm	mm	mm	

Fortgesetzte Tabelle Continued Table
Verwandte Werkzeuge finden Sie auch auf der vorhergehenden Seite!
Related items can be found on the previous page as well!

4,0	10,2	4,2	0,03	+	A04.1820.10.42.03 YR/L	R AGCF L ABGP	X800 X400	3,95	3,45	1,95	13,0	0,3	R A04C.R L A04C.L
4,0	10,2	4,2	0,05	+	A04.1820.10.42.05 YR/L	R ADDK L AN4X	X800 X400	3,95	3,45	1,95	13,0	0,3	R A04C.R L A04C.L
4,0	10,2	4,2	0,15	+	A04.1820.10.42.15 YR/L	R AEH9 L AAPJ	X800 X400	3,95	3,45	1,95	13,0	0,3	R A04C.R L A04C.L
4,0	15,2	4,2	0,03	+	A04.1820.15.42.03 YR/L	R APUB L AKMA	X800 X400	3,95	3,45	1,95	18,0	0,3	R A04C.R L A04C.L
4,0	15,2	4,2	0,05	+	A04.1820.15.42.05 YR/L	R ADN4 L AK2B	X800 X400	3,95	3,45	1,95	18,0	0,3	R A04C.R L A04C.L
4,0	15,2	4,2	0,15	+	A04.1820.15.42.15 YR/L	R AHDX L AGEY	X800 X400	3,95	3,45	1,95	18,0	0,3	R A04C.R L A04C.L
4,0	20,3	4,2	0,03	+	A04.1820.20.42.03 YR/L	R AJ0B L AEPY	X800 X400	3,95	3,45	1,95	23,0	0,3	R A04C.R L A04C.L
4,0	20,3	4,2	0,05	+	A04.1820.20.42.05 YR/L	R AB3A L AHMG	X800 X400	3,95	3,45	1,95	23,0	0,3	R A04C.R L A04C.L
4,0	20,3	4,2	0,15	+	A04.1820.20.42.15 YR/L	R AM3K L ANGF	X800 X400	3,95	3,45	1,95	23,0	0,3	R A04C.R L A04C.L
4,0	25,4	4,2	0,05	+	A04.1820.25.42.05 YR/L	R AMV0 L AFE8	X800 X400	3,95	3,45	1,95	28,0	0,3	R A04C.R L A04C.L
4,0	25,4	4,2	0,15	+	A04.1820.25.42.15 YR/L	R AJT1 L AJ4S	X800 X400	3,95	3,45	1,95	28,0	0,3	R A04C.R L A04C.L
4,0	30,5	4,2	0,05	+	A04.1820.30.42.05 YR/L	R ASFY L ASF1	X800 X400	3,95	3,45	1,95	33,0	0,3	R A04C.R L A04C.L
4,0	35,6	4,2	0,05	+	A04.1820.35.42.05 YR	A2AF	X800 X400	3,95	3,45	1,95	38,0	0,3	A04C.R

Verwandte Werkzeuge finden Sie auch auf der folgenden Seite!
Related items can be found on the following page as well!

Fortgesetzte Tabelle Continued Table

Bestellbeispiel // Order example: A04.1820.10.42.15 YR X800 (R = Rechte Ausführung // Right hand version, X800 = Schneidstoff // Grade)

Ausdrehen

Geeignet ab Bohrungsdurchmesser 4,9 mm.

Boring

For use in bores as of minimum bore diameter 4,9 mm.

Schnittwerte (Start) // Cutting parameters (start)

f	Vc
0,02 mm/U	Seite/Page 429

Passende Klemmhalter auf Seite // Suitable toolholders on page

27, 31, 33, 35, 41, 44, 50, 51, 53, 55, 56, 57, 61, 62, 63, 65, 66, 67, 68, 69

Vergleichbare Werkzeuge auf Seite // Similar tools on page

70

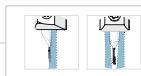
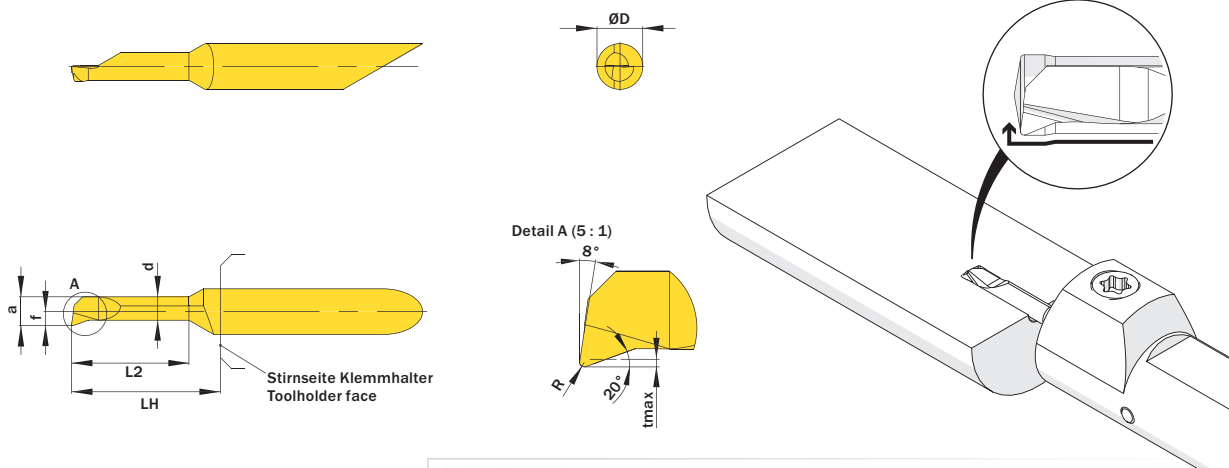


SP
HM
R

Legende
Legend 139

Scan
QR-Code

Oder besuchen Sie // Or Visit
www.simtek.info/cp/1073



Mehr Informationen zur Kühlmittelzufuhr finden Sie auf Seite 22
Additional information about through coolant supply on page 22

ØD	L2	ØDmin (Min. Bohrung) ØDmin (min. bore)	R	Kühlmittelzufuhr Through coolant supply	Artikelnummer Part number	Webcode www.simtek.com/webcode	Unsere erste Wahl Our first choice	a	d	f	LH	tmax	Connectcode www.simtek.com/code
mm	mm	mm	mm				P K M N S	mm	mm	mm	mm	mm	

◀ Fortgesetzte Tabelle
Continued Table

Verwandte Werkzeuge finden Sie auch auf der vorhergehenden Seite!
Related Items can be found on the previous page as well!

5,0	20,3	4,9	0,2	+	A05.1825.20.49.20 YR/L	R AXJC L AXJB X800 X400		4,65	3,95	2,45	23,0	0,4	R A05.R L A05.L
5,0	25,4	4,9	0,2	+	A05.1825.25.49.20 YR/L	R AXJF L AXJE X800 X400		4,65	3,95	2,45	28,0	0,4	R A05.R L A05.L
5,0	30,5	4,9	0,05	+	A05.1825.30.49.05 YR/L	R AXJH L AXJG X800 X400		4,65	3,95	2,45	33,0	0,4	R A05.R L A05.L
5,0	30,5	4,9	0,2	+	A05.1825.30.49.20 YR/L	R AXJK L AXJJ X800 X400		4,65	3,95	2,45	33,0	0,4	R A05.R L A05.L
5,0	35,6	4,9	0,2	+	A05.1825.35.49.20 YR/L	R AXJN L AXJM X800 X400		4,65	3,95	2,45	38,0	0,4	R A05.R L A05.L
5,0	40,6	4,9	0,2	+	A05.1825.40.49.20 YR/L	R AXJQ L AXJP X800 X400		4,65	3,95	2,45	43,0	0,4	R A05.R L A05.L

Verwandte Werkzeuge finden Sie auch auf der folgenden Seite!
Related Items can be found on the following page as well!

▶ Fortgesetzte Tabelle
Continued Table

Bestellbeispiel // Order example: **A05.1825.20.49.20 YR X800** (R = Rechte Ausführung // Right hand version, X800 = Schneidstoff // Grade)

Ausdrehen

Geeignet ab Bohrungsdurchmesser 5,2 mm.

Boring

For use in bores as of minimum bore diameter 5,2 mm.

Schnittwerte (Start) // Cutting parameters (start)

f	Vc
0,02 mm/U	Seite/Page 429

Passende Klemmhalter auf Seite // Suitable toolholders on page

27, 31, 33, 35, 41, 44, 50, 51, 53, 55, 56, 57, 61, 62, 63, 65, 66, 67, 68, 69

Vergleichbare Werkzeuge auf Seite // Similar tools on page

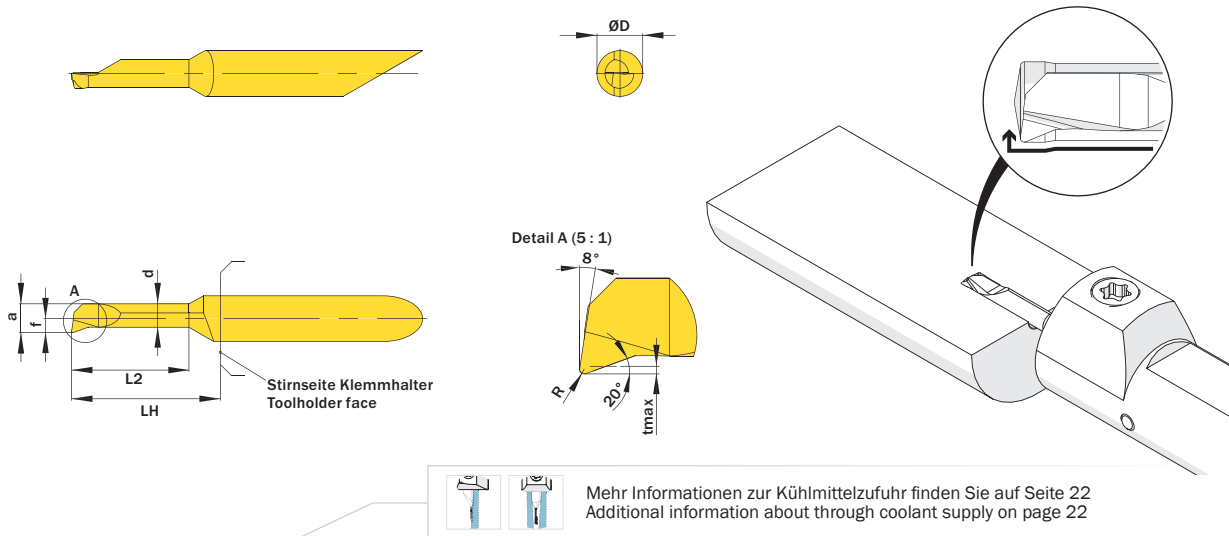
70

SP
HM
R

Legende
Legend **139**

Scan
QR-Code

Oder besuchen Sie // Or Visit
www.simtek.info/cp/1041



ØD	L2	ØDmin (Min. Bohrung) ØDmin (min. bore)	R	Kühlmittelzufuhr Through coolant supply	Artikelnummer Part number	Webcode www.simtek.com/webcode	Unsere erste Wahl Our first choice	a	d	f	LH	tmax	Connectcode www.simtek.com/code
mm	mm	mm	mm				P K M N S	mm	mm	mm	mm	mm	

Fortgesetzte Tabelle Continued Table **Verwandte Werkzeuge finden Sie auch auf der vorhergehenden Seite!**
Related Items can be found on the previous page as well!

5,0	10,2	5,2	0,05	+	A05.1825.10.52.05 YR/L	R AS4G L ATVZ	X800 X400	4,95	4,25	2,45	13,0	0,5	R A05.R L A05.L
5,0	10,2	5,2	0,2	+	A05.1825.10.52.20 YR/L	R AFCW L ADCU	X800 X400	4,95	4,25	2,45	13,0	0,5	R A05.R L A05.L
5,0	15,2	5,2	0,03	+	A05.1825.15.52.03 YR/L	R ATV0 L AKBB	X800 X400	4,95	4,25	2,45	18,0	0,5	R A05.R L A05.L
5,0	15,2	5,2	0,05	+	A05.1825.15.52.05 YR/L	R AM69 L AH0M	X800 X400	4,95	4,25	2,45	18,0	0,5	R A05.R L A05.L
5,0	15,2	5,2	0,2	+	A05.1825.15.52.20 YR/L	R AF4Y L ANMN	X800 X400	4,95	4,25	2,45	18,0	0,5	R A05.R L A05.L
5,0	20,3	5,2	0,05	+	A05.1825.20.52.05 YR/L	R AD00 L AKA1	X800 X400	4,95	4,25	2,45	23,0	0,5	R A05.R L A05.L
5,0	20,3	5,2	0,2	+	A05.1825.20.52.20 YR/L	R AM8M L AM55	X800 X400	4,95	4,25	2,45	23,0	0,5	R A05.R L A05.L
5,0	25,4	5,2	0,2	+	A05.1825.25.52.20 YR/L	R AFSB L AEHN	X800 X400	4,95	4,25	2,45	28,0	0,5	R A05.R L A05.L
5,0	30,5	5,2	0,05	+	A05.1825.30.52.05 YR/L	R AD3G L AH4N	X800 X400	4,95	4,25	2,45	33,0	0,5	R A05.R L A05.L
5,0	30,5	5,2	0,2	+	A05.1825.30.52.20 YR/L	R AFY1 L AK66	X800 X400	4,95	4,25	2,45	33,0	0,5	R A05.R L A05.L
5,0	35,6	5,2	0,2	+	A05.1825.35.52.20 YR/L	R AND4 L AEC2	X800 X400	4,95	4,25	2,45	38,0	0,5	R A05.R L A05.L
5,0	40,6	5,2	0,2	+	A05.1825.40.52.20 YR/L	R AMQK L AHH4	X800 X400	4,95	4,25	2,45	43,0	0,5	R A05.R L A05.L

Verwandte Werkzeuge finden Sie auch auf der folgenden Seite!
Related Items can be found on the following page as well!

Fortgesetzte Tabelle Continued Table

Bestellbeispiel // Order example: **A05.1825.20.52.20 YR X800** (R = Rechte Ausführung // Right hand version, X800 = Schneidstoff // Grade)

Ausdrehen

Geeignet ab Bohrungsdurchmesser 5,9 mm.

Boring

For use in bores as of minimum bore diameter 5,9 mm.

Schnittwerte (Start) // Cutting parameters (start)

f	Vc
0,02 mm/U	Seite/Page 429

Passende Klemmhalter auf Seite // Suitable toolholders on page

28, 31, 36, 42, 45, 50, 51, 53, 55,
56, 58, 61, 62, 64, 65, 66, 67, 68,
69

Vergleichbare Werkzeuge auf Seite // Similar tools on page

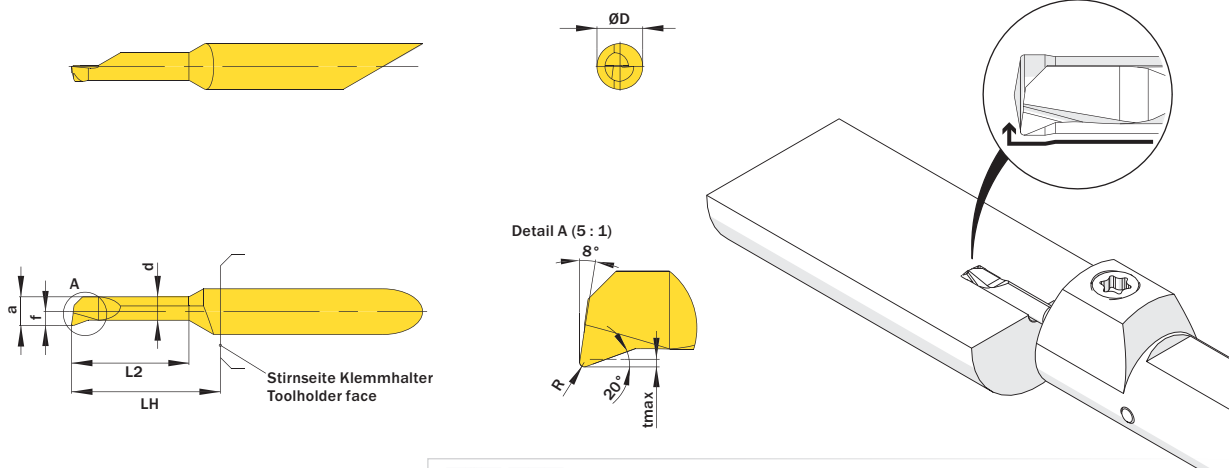
70



Legende
Legend 139



Oder besuchen Sie // Or Visit
www.simtek.info/cp/1074



Mehr Informationen zur Kühlmittelzufuhr finden Sie auf Seite 22
Additional information about through coolant supply on page 22

ØD	L2	ØDmin (Min. Bohrung) ØDmin (min. bore)	R	Kühlmittelzufuhr Through coolant supply	Artikelnummer Part number	Webcode www.simtek.com/webcode	Unsere erste Wahl Our first choice	a	d	f	LH	tmax	Connectcode www.simtek.com/code
mm	mm	mm	mm				P K M N S	mm	mm	mm	mm	mm	

Fortgesetzte Tabelle Continued Table
Verwandte Werkzeuge finden Sie auch auf der vorhergehenden Seite!
Related Items can be found on the previous page as well!

6,0	35,6	5,9	0,2	+	A06.1830.35.59.20 YR/L	R AXH6 L AXH5	X800 X400	5,65	4,95	2,95	38,0	0,4	R A06.R L A06.L
6,0	40,6	5,9	0,2	+	A06.1830.40.59.20 YR/L	R AXH8 L AXH7	X800 X400	5,65	4,95	2,95	43,0	0,4	R A06.R L A06.L
6,0	45,7	5,9	0,2	+	A06.1830.45.59.20 YR	A2AG	X800 X400	5,65	4,95	2,95	48,0	0,4	A06.R

Verwandte Werkzeuge finden Sie auch auf der folgenden Seite!
Related Items can be found on the following page as well!

Fortgesetzte Tabelle Continued Table

Bestellbeispiel // Order example: **A06.1830.35.59.20 YR X800** (R = Rechte Ausführung // Right hand version, X800 = Schneidstoff // Grade)

Ausdrehen

Geeignet ab Bohrungsdurchmesser 6,2 mm.

Boring

For use in bores as of minimum bore diameter 6,2 mm.

Schnittwerte (Start) // Cutting parameters (start)

f	Vc
0,02 mm/U	Seite/Page 429

Passende Klemmhalter auf Seite // Suitable toolholders on page

28, 29, 31, 36, 22, 42, 45, 46, 50,
51, 52, 53, 54, 55, 56, 58, 61, 62,
64, 65, 66, 67, 68, 69

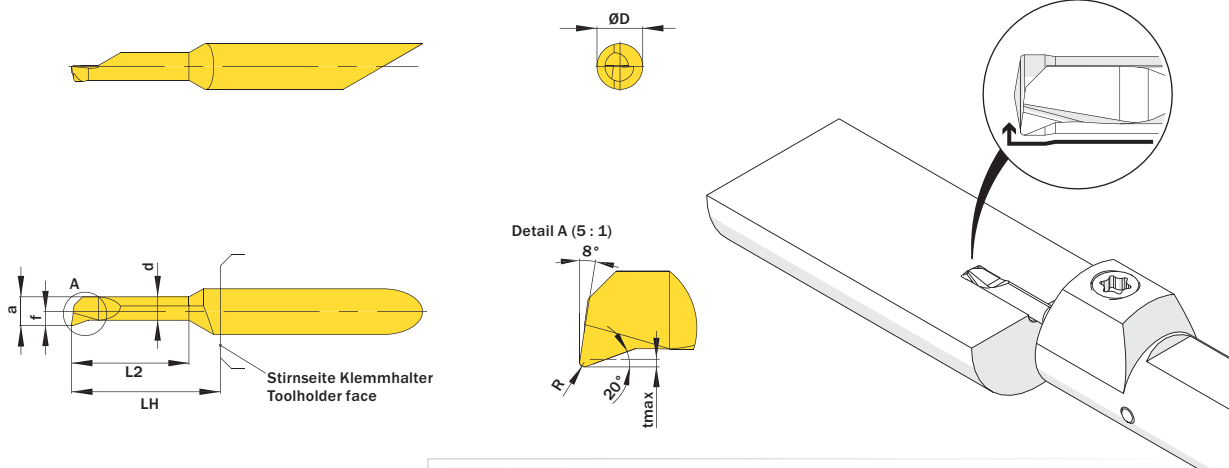
Vergleichbare Werkzeuge auf Seite // Similar tools on page

70



Legende
Legend 139

Scan QR-Code Oder besuchen Sie // Or Visit
www.simtek.info/cp/1042



Mehr Informationen zur Kühlmittelzufuhr finden Sie auf Seite 22
Additional information about through coolant supply on page 22

ØD	L2	ØDmin (Min. Bohrung) ØDmin (min. bore)	R	Kühlmittelzufuhr Through coolant supply	Artikelnummer Part number	Webcode www.simtek.com/webcode	Unsere erste Wahl Our first choice	a	d	f	LH	tmax	Connectcode www.simtek.com/code
mm	mm	mm	mm				P K M N S	mm	mm	mm	mm	mm	

Fortgesetzte Tabelle
Continued Table

Verwandte Werkzeuge finden Sie auch auf der vorhergehenden Seite!
Related items can be found on the previous page as well!

▼ ØDmin (Min. Bohrung) // ØDmin (min. bore) = 6,2 mm

6,0	15,2	6,2	0,2	+	A06.1830.15.62.20 YR/L	R AG74	L AGKE	X800 X400	5,95	5,25	2,95	18,0	0,5	R	A06.R	L	A06.L
6,0	20,3	6,2	0,05	+	A06.1830.20.62.05 YR/L	R AEF5	L AQ95	X800 X400	5,95	5,25	2,95	23,0	0,5	R	A06.R	L	A06.L
6,0	20,3	6,2	0,2	+	A06.1830.20.62.20 YR/L	R AHDQ	L AK50	X800 X400	5,95	5,25	2,95	23,0	0,5	R	A06.R	L	A06.L
6,0	25,4	6,2	0,2	+	A06.1830.25.62.20 YR/L	R AMJG	L ADFD	X800 X400	5,95	5,25	2,95	28,0	0,5	R	A06.R	L	A06.L
6,0	30,5	6,2	0,05	+	A06.1830.30.62.05 YR/L	R AMDL	L ATVY	X800 X400	5,95	5,25	2,95	33,0	0,5	R	A06.R	L	A06.L
6,0	30,5	6,2	0,2	+	A06.1830.30.62.20 YR/L	R AFDC	L AKDU	X800 X400	5,95	5,25	2,95	33,0	0,5	R	A06.R	L	A06.L
6,0	35,6	6,2	0,2	+	A06.1830.35.62.20 YR/L	R ABT1	L AEG8	X800 X400	5,95	5,25	2,95	38,0	0,5	R	A06.R	L	A06.L
6,0	40,6	6,2	0,2	+	A06.1830.40.62.20 YR/L	R AC3S	L AEQ0	X800 X400	5,95	5,25	2,95	43,0	0,5	R	A06.R	L	A06.L
6,0	50,8	6,2	0,2	+	A06.1830.50.62.20 YR/L	R A2AH	L A4YD	X800 X400	5,95	5,25	2,95	53,0	0,5	R	A06.R	L	A06.L

▼ ØDmin (Min. Bohrung) // ØDmin (min. bore) = 7,2 mm

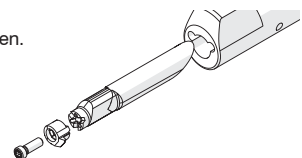
7,0	25,4	7,2	0,2	+	A07.1835.25.72.20 YR/L	R APJJ	L ADX9	X800 X400	6,95	6,25	3,45	28,0	0,5	R	A07.R	L	A07.L
7,0	30,5	7,2	0,2	+	A07.1835.30.72.20 YR/L	R AHXT	L AJTS	X800 X400	6,95	6,25	3,45	33,0	0,5	R	A07.R	L	A07.L
7,0	35,6	7,2	0,2	+	A07.1835.35.72.20 YR/L	R AMGJ	L AJZQ	X800 X400	6,95	6,25	3,45	38,0	0,5	R	A07.R	L	A07.L
7,0	40,6	7,2	0,2	+	A07.1835.40.72.20 YR/L	R ABCQ	L AC04	X800 X400	6,95	6,25	3,45	43,0	0,5	R	A07.R	L	A07.L
7,0	45,7	7,2	0,2	+	A07.1835.45.72.20 YR/L	R AMXA	L ACW5	X800 X400	6,95	6,25	3,45	48,0	0,5	R	A07.R	L	A07.L
7,0	50,8	7,2	0,2	+	A07.1835.50.72.20 YR/L	R AKWE	L AM5B	X800 X400	6,95	6,25	3,45	53,0	0,5	R	A07.R	L	A07.L
7,0	60,8	7,2	0,2	+	A07.1835.60.72.20 YR	A2AJ	X800 X400	6,95	6,25	3,45	63,0	0,5				A07.R	

Bestellbeispiel // Order example: **A06.1830.15.62.20 YR X800** (R = Rechte Ausführung // Right hand version, X800 = Schneidstoff // Grade)

Die Werkzeugreihe simturn D07, bietet für das Ausdrehen von Bohrungen ab Ø 7,0 mm eine modulare Lösung bestehend aus einem Adapter für simturn A06 Trägerwerkzeuge und stirnseitig verschraubten simturn D07 Schneidplatten.

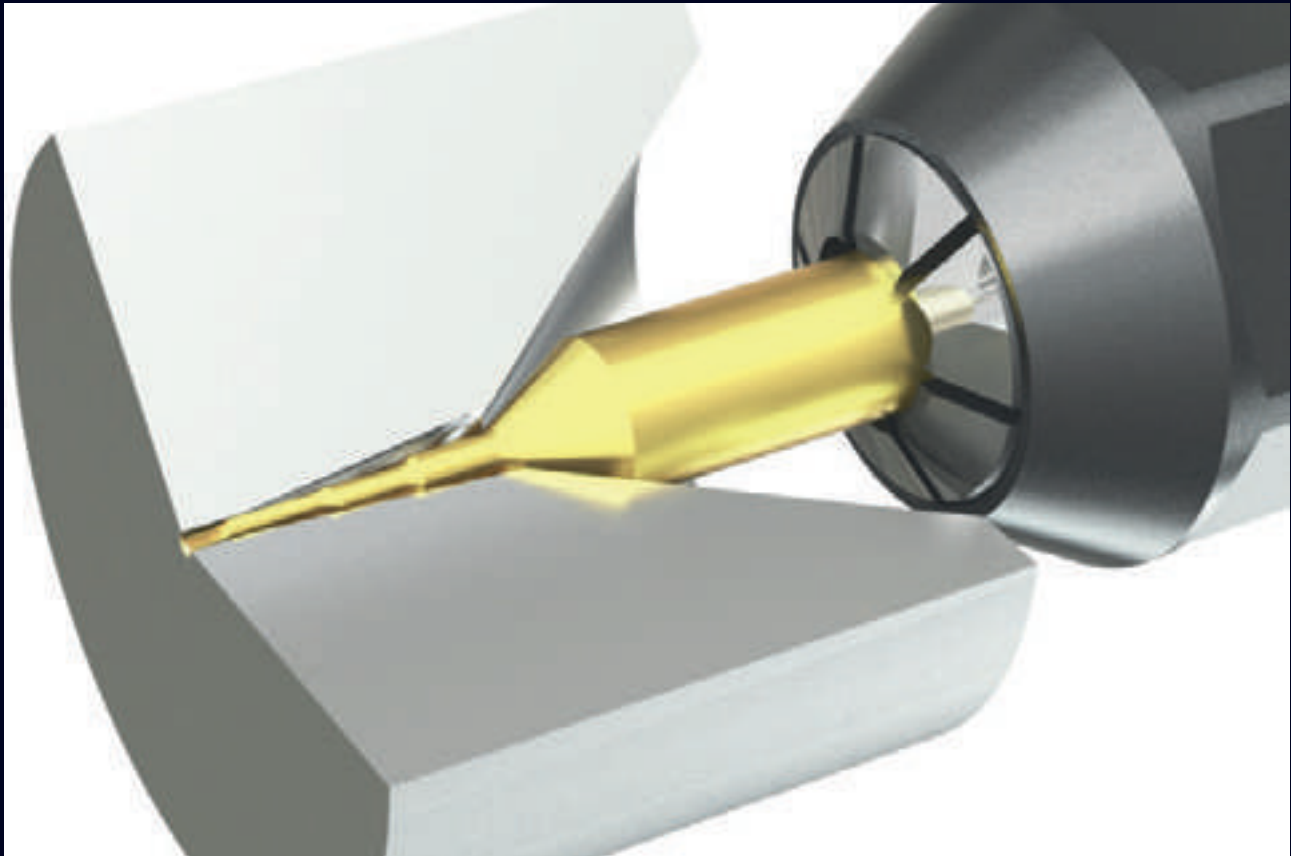
The product group simturn D07 provides a modular solution for boring applications in bores as of Ø 7,0 mm. The system consists of an adapter for simturn A06 toolholders and the cutting inserts simturn D07.

Adapter auf Seite // Adapter on page **162** | Schneidplatten // Cutting inserts **168**



Individualwerkzeuge // Customized tools

Kundenindividuelle Werkzeuglösungen Customer-specific tooling solutions



Ausdrehen einer tiefen, sich stark verjüngenden Bohrung mit mehrfach abgesetztem simturn AX - Schneideinsatz.

Boring of a deep, strongly tapered bore with multiple stepped simturn AX cutting insert.

SIMTEK Individualwerkzeuge bieten unzählige Vorteile! Neben unserem Anspruch, jeweils die qualitativ bestmögliche Werkzeuglösung für Ihre Anwendung anzubieten, ist es auch unser Bestreben Ihnen durch ein SIMTEK Individualwerkzeug den größtmöglichen wirtschaftlichen Nutzen zu liefern! Tausende, aktuell erfolgreich eingesetzte Individualwerkzeuge bestätigen dies!

Kontaktieren Sie uns und lassen auch Sie sich von den Vorteilen mit SIMTEK Individualwerkzeugen überzeugen!

SIMTEK individual tools offer countless advantages! In addition to our goal to offer the qualitatively best possible tooling solution for your application, we also aspire to provide you with the greatest possible economic benefit from a customized SIMTEK tool! Thousands of currently successfully used SIMTEK individual tools confirm this!

Contact us and convince yourself of the advantages of SIMTEK individual tools!

simturnAX
SIMTEK small part machining type AX

Ausdrehen mit spezieller Spanfläche

Mit optimierter Spanbildung durch spezielle, runde Spanfläche. Zentrierte Ausführung für optimierte Kühlung und Spitzenhöhe in Verbindung mit passendem Halter. Geeignet ab Bohrungsdurchmesser 1,0 mm.

Boring with Special Chip Former

Special chip former for improved chip control. Centered edition with improved coolant supply and cutting edge positioning. For use in bores as of minimum bore diameter 1,0 mm.

Schnittwerte (Start) // Cutting parameters (start)	
f 0,02 mm/U	Vc Seite/Page 429

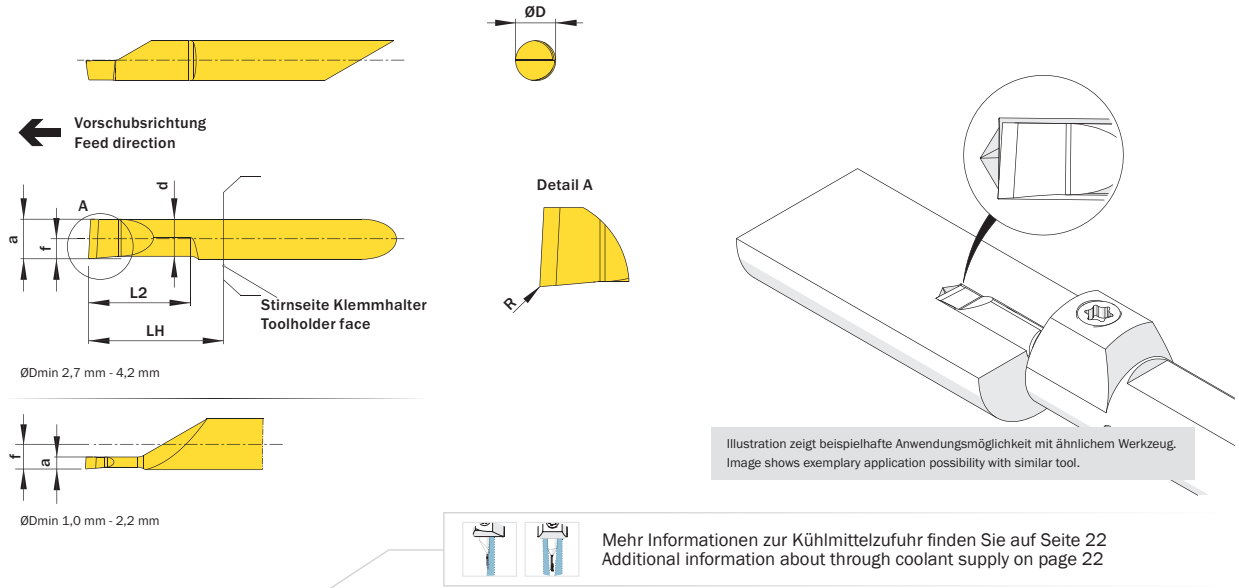
Passende Klemmhalter auf Seite // Suitable toolholders on page
31, 32, 34, 40, 41, 43, 50, 51, 53, 55, 56, 57, 60, 62, 63, 66, 67, 68, 69

SP
HM
R

Legende
Legend **139**

Scan
QR-Code

Oder besuchen Sie // Or Visit
www.simtek.info/cp/1096



ØD	L2	ØDmin (Min. Bohrung) ØDmin (min. bore)	R	Kühlmittelzufuhr Through coolant supply	Artikelnummer Part number	Webcode www.simtek.com/webcode	Unsere erste Wahl Our first choice	a	d	f	LH	Connectcode www.simtek.com/code
mm	mm	mm	mm				P K M N S	mm	mm	mm	mm	

Fortgesetzte Tabelle // Continued Table
Verwandte Werkzeuge finden Sie auch auf der vorhergehenden Seite!
Related items can be found on the previous page as well!

▼ ØDmin (Min. Bohrung) // ØDmin (min. bore) = 1,0 mm												
4,0	4,1	1,0	0,05	+	A04.8704.04.10.05 YS R	AX3P	X800 X400	0,95	0,8	1,95	13,0	A04C.R
▼ ØDmin (Min. Bohrung) // ØDmin (min. bore) = 1,2 mm												
4,0	6,1	1,2	0,05	+	A04.8705.06.12.05 YS R	AX3Q	X800 X400	1,1	0,95	1,95	13,0	A04C.R
▼ ØDmin (Min. Bohrung) // ØDmin (min. bore) = 1,4 mm												
4,0	6,1	1,4	0,05	+	A04.8706.06.14.05 YS R	AX3N	X800 X400	1,3	1,15	1,95	13,0	A04C.R
▼ ØDmin (Min. Bohrung) // ØDmin (min. bore) = 1,7 mm												
4,0	6,1	1,7	0,05	+	A04.8707.06.17.05 YS R	AX9J	X800 X400	1,45	3,95	1,95	13,0	A04C.R
4,0	6,1	1,7	0,1	+	A04.8707.06.17.10 YS R	AX1X	X800 X400	1,45	1,3	1,95	13,0	A04C.R
▼ ØDmin (Min. Bohrung) // ØDmin (min. bore) = 2,2 mm												
4,0	9,1	2,2	0,05	+	A04.8710.09.22.05 YS R	AX3U	X800 X400	1,95	1,8	1,95	13,0	A04C.R
▼ ØDmin (Min. Bohrung) // ØDmin (min. bore) = 2,7 mm												
4,0	10,2	2,7	0,05	+	A04.8712.10.27.05 YS R	AX56	X800 X400	2,45	2,3	1,95	13,0	A04C.R
4,0	10,2	2,7	0,1	+	A04.8712.10.27.10 YS R	AX3M	X800 X400	2,45	2,3	1,95	13,0	A04C.R
4,0	15,2	2,7	0,05	+	A04.8712.15.27.05 YS R	AYCE	X800 X400	2,45	2,3	1,95	18,0	A04C.R
▼ ØDmin (Min. Bohrung) // ØDmin (min. bore) = 3,2 mm												
4,0	10,2	3,2	0,05	+	A04.8715.10.32.05 YS R	AX55	X800 X400	2,95	2,8	1,95	13,0	A04C.R
4,0	10,2	3,2	0,1	+	A04.8715.10.32.10 YS R	AX3T	X800 X400	2,95	2,8	1,95	13,0	A04C.R
4,0	15,2	3,2	0,05	+	A04.8715.15.32.05 YS R	AYCG	X800 X400	2,95	2,8	1,95	18,0	A04C.R
▼ ØDmin (Min. Bohrung) // ØDmin (min. bore) = 4,2 mm												
4,0	10,2	4,2	0,05	+	A04.8720.10.42.05 YS R	AXYU	X800 X400	3,95	3,7	1,95	13,0	A04C.R
4,0	15,2	4,2	0,05	+	A04.8720.15.42.05 YS R	AX54	X800 X400	3,95	3,7	1,95	18,0	A04C.R
4,0	15,2	4,2	0,1	+	A04.8720.15.42.10 YS R	AX3S	X800 X400	3,95	3,7	1,95	18,0	A04C.R

Bestellbeispiel // Order example: **A04.8705.06.12.05 YS R X800** (R = Rechte Ausführung // Right hand version, X800 = Schneidstoff // Grade)

Ausdrehen mit spezieller Spanfläche

Mit optimierter Spanbildung durch spezielle, runde Spanfläche und Spannutt. Zentrierte Ausführung für optimierte Kühlung und Spitzenhöhe in Verbindung mit passendem Halter. Geeignet ab Bohrungsdurchmesser 4,2 mm.

Boring with special chip former

Special chip former and chip flute for improved chip control. Centered edition with improved coolant supply and cutting edge positioning. For use in bores as of minimum bore diameter 4,2 mm.

Schnittwerte (Start) // Cutting parameters (start)	
f	Vc
0,02 mm/U	Seite/Page 429

Passende Klemmhalter auf Seite // Suitable toolholders on page
 26, 27, 28, 29, 31, 33, 34, 35, 36,
 37, 40, 41, 42, 43, 44, 45, 46, 50,
 51, 52, 53, 54, 55, 56, 57, 58, 60,
 61, 62, 63, 64, 65, 66, 67, 68, 69

SP

HM

R

Legende
 Legend

139

Oder besuchen Sie // Or Visit
www.simtek.info/cp/1227

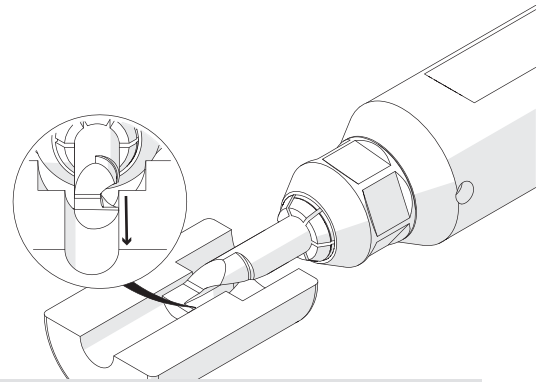
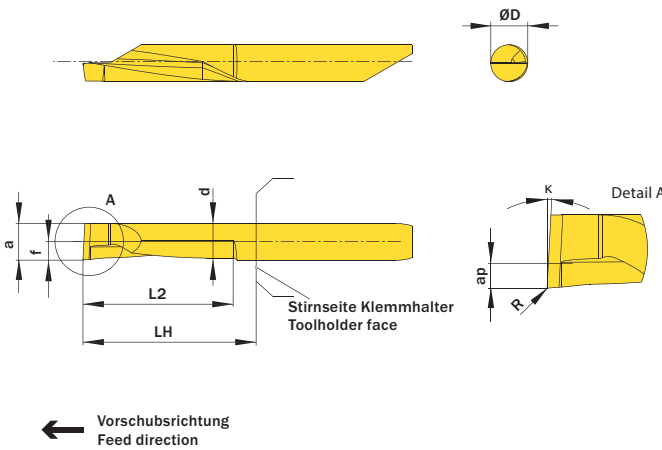


Illustration zeigt beispielhafte Anwendungsmöglichkeit mit ähnlichem Werkzeug.
 Image shows exemplary application possibility with similar tool.

Mehr Informationen zur Kühlmittelzufuhr finden Sie auf Seite 22
 Additional information about through coolant supply on page 22

ØD	L2	ØDmin (Min. Bohrung) ØDmin (min. bore)	R	Kühlmittelzufuhr Through coolant supply	Artikelnummer Part number	Webcode www.simtek.com/webcode	Unsere erste Wahl Our first choice	k	a	ap	d	f	LH	Connectcode www.simtek.com/code
mm	mm	mm	mm				P K M N S		mm	mm	mm	mm	mm	
▼ ØDmin (Min. Bohrung) // ØDmin (min. bore) = 4,2 mm														
4,0	30,5	4,2	0,08	+	A04.1H20.30.42.07 YS R	A1CY	X800 X400	8°	3,95	0,21	3,55	1,95	38,0	A04.R
4,0	30,5	4,2	0,05	+	A04.5H20.30.42.05 YS R	A1C0	X800 X400	50°	3,95	0,21	3,55	1,95	38,0	A04.R
▼ ØDmin (Min. Bohrung) // ØDmin (min. bore) = 5,2 mm														
5,0	40,6	5,2	0,08	+	A05.1H25.40.52.07 YS R	A1C2	X800 X400	8°	4,95	0,26	4,55	2,45	48,0	A05.R
5,0	40,6	5,2	0,05	+	A05.5H25.40.52.05 YS R	A1C4	X800 X400	50°	4,95	0,26	4,55	2,45	48,0	A05.R
5,0	15,2	5,2	0,05	+	A05.8H25.15.52.05 YS R	A020	X800 X400	3°	4,95	0,26	4,7	2,45	23,0	A05.R
5,0	20,3	5,2	0,05	+	A05.8H25.20.52.05 YS R	AYCU	X800 X400	3°	4,95	0,26	4,7	2,45	28,0	A05.R
5,0	20,3	5,2	0,1	+	A05.8H25.20.52.10 YS R	AZXY	X800 X400	3°	4,95	0,26	4,7	2,45	28,0	A05.R
5,0	30,5	5,2	0,1	+	A05.8H25.30.52.10 YS R	AZXX	X800 X400	3°	4,95	0,26	4,7	2,45	38,0	A05.R
▼ ØDmin (Min. Bohrung) // ØDmin (min. bore) = 6,2 mm														
6,0	45,7	6,2	0,05	+	A06.5H30.45.62.05 YS R	A1C8	X800 X400	50°	5,95	0,31	5,5	2,95	53,0	A06.R
6,0	15,2	6,2	0,15	+	A06.8H30.15.62.15 YS R	A022	X800 X400	3°	5,95	0,31	5,7	2,95	23,0	A06.R
6,0	20,3	6,2	0,15	+	A06.8H30.20.62.15 YS R	AX22	X800 X400	3°	5,95	0,31	5,7	2,95	28,0	A06.R
▼ ØDmin (Min. Bohrung) // ØDmin (min. bore) = 7,2 mm														
7,0	55,8	7,2	0,08	+	A07.1H35.55.72.07 YS R	A1DA	X800 X400	8°	6,95	0,36	6,5	3,45	63,0	A07.R
7,0	55,8	7,2	0,05	+	A07.5H35.55.72.05 YS R	A1DC	X800 X400	50°	6,95	0,36	6,5	3,45	63,0	A07.R

Bestellbeispiel // Order example: **A05.8H25.20.52.05 YS R X800** (R = Rechte Ausführung // Right hand version, X800 = Schneidstoff // Grade)

Ausdrehen mit spezieller Spantreppe

Mit optimierter Spanbildung durch spezielle Spantreppe. Zentrierte Ausführung für optimierte Kühlung und Spitzenhöhe in Verbindung mit passendem Halter. Geeignet ab Bohrungsdurchmesser 2,7 mm.

Boring with Special Chip Former

Special chip former for improved chip control. Centered edition with improved coolant supply and cutting edge positioning. For use in bores as of minimum bore diameter 2,7 mm.

Schnittwerte (Start) // Cutting parameters (start)	
f 0,02 mm/U	Vc Seite/Page 429

Passende Klemmhalter auf Seite // Suitable toolholders on page
27, 31, 32, 33, 34, 35, 40, 41, 43,
44, 50, 51, 53, 55, 56, 57, 60, 61,
62, 63, 65, 66, 67, 68, 69

SP
HM
R

Legende
Legend **139**

Scan
QR-Code

Oder besuchen Sie // Or Visit
www.simtek.info/cp/1045

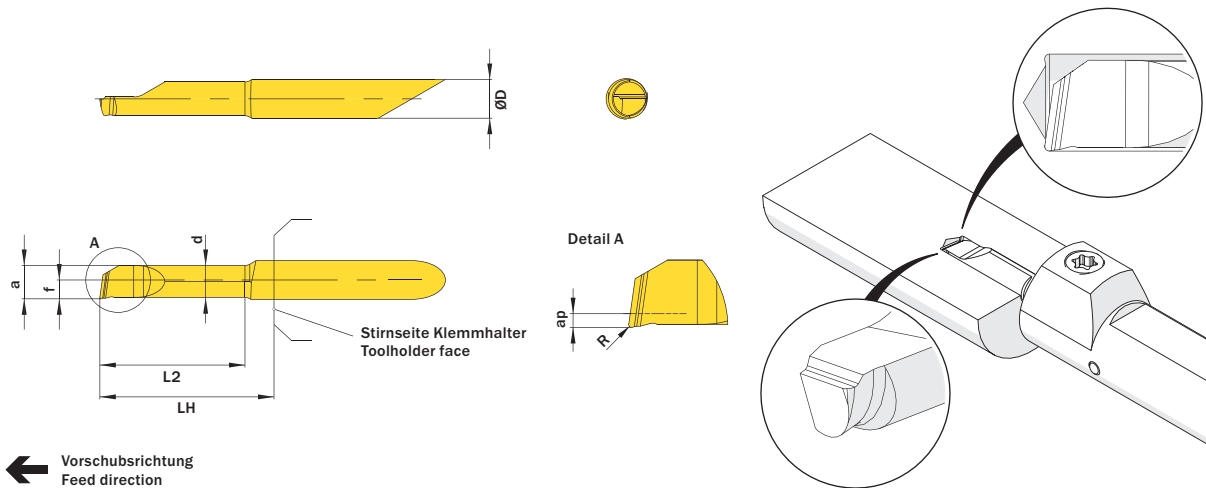


Abbildung zeigt / Drawing shows: A04.0C17.15.37.15 YER

Mehr Informationen zur Kühlmittelzufuhr finden Sie auf Seite 22
Additional information about through coolant supply on page 22

ØD	L2	ØDmin (Min. Bohrung) ØDmin (min. bore)	R	Kühlmittelzufuhr Through coolant supply	Artikelnummer Part number	Webcode www.simtek.com/webcode	Unsere erste Wahl Our first choice	a	ap	d	f	LH	Connectcode www.simtek.com/code
mm	mm	mm	mm				P K M N S	mm	mm	mm	mm	mm	
▼ ØDmin (Min. Bohrung) // ØDmin (min. bore) = 2,7 mm													
4,0	10,2	2,7	0,15	+	A04.0C12.10.27.15 YER/L	R AYE3 L AYE2	X800 X400	2,45	0,4	2,3	1,95	13,0	R A04C.R L A04C.L
4,0	15,2	2,7	0,15	+	A04.0C12.15.27.15 YER/L	R AUPY L AUPZ	X800 X400	2,45	0,4	2,3	1,95	18,0	R A04C.R L A04C.L
▼ ØDmin (Min. Bohrung) // ØDmin (min. bore) = 3,2 mm													
4,0	10,2	3,2	0,15	+	A04.0C15.10.32.15 YER/L	R AYE5 L AYE4	X800 X400	2,95	0,4	2,8	1,95	13,0	R A04C.R L A04C.L
4,0	15,2	3,2	0,15	+	A04.0C15.15.32.15 YER/L	R AUP0 L AUP1	X800 X400	2,95	0,4	2,8	1,95	18,0	R A04C.R L A04C.L
▼ ØDmin (Min. Bohrung) // ØDmin (min. bore) = 3,7 mm													
4,0	10,2	3,7	0,15	+	A04.0C17.10.37.15 YER/L	R AYE6 L AYE7	X800 X400	3,45	0,5	3,3	1,95	13,0	R A04C.R L A04C.L
4,0	15,2	3,7	0,15	+	A04.0C17.15.37.15 YER/L	R AUPT L AUPS	X800 X400	3,45	0,5	3,3	1,95	18,0	R A04C.R L A04C.L
4,0	20,3	3,7	0,15	+	A04.0C17.20.37.15 YER/L	R ATUE L ATUF	X800 X400	3,45	0,5	3,3	1,95	23,0	R A04C.R L A04C.L
▼ ØDmin (Min. Bohrung) // ØDmin (min. bore) = 4,2 mm													
4,0	10,2	4,2	0,15	+	A04.0020.10.42.15 YER/L	R AVUP L AW4V	X800 X400	3,95	0,5	3,8	1,95	13,0	R A04C.R L A04C.L
4,0	15,2	4,2	0,15	+	A04.0020.15.42.15 YER/L	R ASE4 L ASE5	X800 X400	3,95	0,5	3,8	1,95	18,0	R A04C.R L A04C.L
4,0	15,2	4,2	0,4	+	A04.0020.15.42.40 YER	A4XD	X800 X400	3,95	0,5	3,8	1,95	18,0	A04C.R new
4,0	20,3	4,2	0,15	+	A04.0020.20.42.15 YER/L	R ASE6 L ASE7	X800 X400	3,95	0,5	3,8	1,95	23,0	R A04C.R L A04C.L
4,0	25,4	4,2	0,15	+	A04.0020.25.42.15 YER/L	R AVUQ L AW4W	X800 X400	3,95	0,5	3,8	1,95	28,0	R A04C.R L A04C.L
▼ ØDmin (Min. Bohrung) // ØDmin (min. bore) = 5,2 mm													
5,0	10,2	5,2	0,2	+	A05.0025.10.52.20 YER/L	R AS74 L AS75	X800 X400	4,95	0,6	4,75	2,45	13,0	R A05.R L A05.L
5,0	10,2	5,2	0,4	+	A05.0025.10.52.40 YER/L	R AY8B L A065	X800 X400	4,95	0,6	4,75	2,45	13,0	R A05.R L A05.L
5,0	15,2	5,2	0,2	+	A05.0025.15.52.20 YER/L	R AS77 L AS76	X800 X400	4,95	0,6	4,75	2,45	18,0	R A05.R L A05.L
5,0	20,3	5,2	0,2	+	A05.0025.20.52.20 YER/L	R ASE9 L ASE8	X800 X400	4,95	0,6	4,75	2,45	23,0	R A05.R L A05.L
5,0	25,4	5,2	0,2	+	A05.0025.25.52.20 YER/L	R ASFA L ASFB	X800 X400	4,95	0,6	4,75	2,45	28,0	R A05.R L A05.L
5,0	30,5	5,2	0,2	+	A05.0025.30.52.20 YER/L	R AS79 L AS78	X800 X400	4,95	0,6	4,75	2,45	33,0	R A05.R L A05.L

Bestellbeispiel // Order example: **A05.0025.25.52.20 YER X800** (R = Rechte Ausführung // Right hand version, X800 = Schneidstoff // Grade)

simturn AX
simturn DX
simturn PX
simturn H2
simturn K2
simturn C4
simturn GX
simturn E3
simturn E12
simturn FX
simturn Decolletage
simturn OA
Index

Ausdrehen mit spezieller Spantreppe

Mit optimierter Spanbildung durch spezielle Spantreppe. Zentrierte Ausführung für optimierte Kühlung und Spitzenhöhe in Verbindung mit passendem Halter. Geeignet ab Bohrungsdurchmesser 6,2 mm.

Boring with Special Chip Former

Special chip former for improved chip control. Centered edition with improved coolant supply and cutting edge positioning. For use in bores as of minimum bore diameter 6,2 mm.

Schnittwerte (Start) // Cutting parameters (start)

f	Vc
0,02 mm/U	Seite/Page 429

Passende Klemmhalter auf Seite // Suitable toolholders on page

28, 29, 31, 36, 37, 42, 45, 46, 50, 51, 52, 53, 54, 55, 56, 58, 61, 62, 64, 65, 66, 67, 68, 69



SP
HM
R

Legende
Legend **139**

Scan
QR-Code

Oder besuchen Sie // Or Visit
www.simtek.info/cp/1107

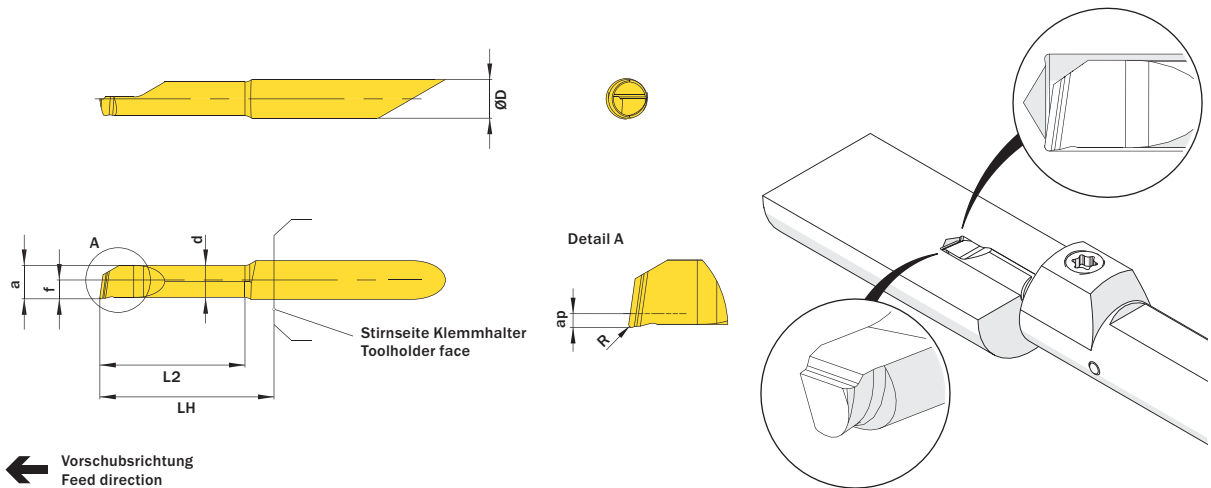


Abbildung zeigt / Drawing shows: A04.0C17.15.37.15 YER

Mehr Informationen zur Kühlmittelzufuhr finden Sie auf Seite 22
 Additional information about through coolant supply on page 22

ØD	L2	ØDmin (Min. Bohrung) ØDmin (min. bore)	R	Kühlmittelzufuhr Through coolant supply	Artikelnummer Part number	Webcode www.simtek.com/webcode	Unsere erste Wahl Our first choice	a	ap	d	f	LH	Connectcode www.simtek.com/code
mm	mm	mm	mm				P K M N S	mm	mm	mm	mm	mm	
▼ ØDmin (Min. Bohrung) // ØDmin (min. bore) = 6,2 mm													
6,0	15,2	6,2	0,2	+	A06.0030.15.62.20 YER/L	R AS8B L AS8A	X800 X400	5,95	0,75	5,7	2,95	18,0	R A06.R L A06.L
6,0	20,3	6,2	0,2	+	A06.0030.20.62.20 YER/L	R AS8D L AS8C	X800 X400	5,95	0,75	5,7	2,95	23,0	R A06.R L A06.L
6,0	25,4	6,2	0,2	+	A06.0030.25.62.20 YER/L	R ASFD L ASFC	X800 X400	5,95	0,75	5,7	2,95	28,0	R A06.R L A06.L
6,0	30,5	6,2	0,2	+	A06.0030.30.62.20 YER/L	R ASFF L ASFE	X800 X400	5,95	0,75	5,7	2,95	33,0	R A06.R L A06.L
6,0	40,6	6,2	0,2	+	A06.0030.40.62.20 YER/L	R AWYQ L AWYP	X800 X400	5,95	0,75	5,7	2,95	43,0	R A06.R L A06.L
▼ ØDmin (Min. Bohrung) // ØDmin (min. bore) = 7,2 mm													
7,0	25,4	7,2	0,2	+	A07.0035.25.72.20 YER/L	R AS8F L AS8E	X800 X400	6,95	0,9	6,65	3,45	28,0	R A07.R L A07.L
7,0	30,5	7,2	0,2	+	A07.0035.30.72.20 YER/L	R ASFH L ASFG	X800 X400	6,95	0,9	6,65	3,45	33,0	R A07.R L A07.L
7,0	35,6	7,2	0,2	+	A07.0035.35.72.20 YER/L	R ASFK L ASFJ	X800 X400	6,95	0,9	6,65	3,45	38,0	R A07.R L A07.L
7,0	40,6	7,2	0,2	+	A07.0035.40.72.20 YER/L	R AZ4Q L AZ4S	X800 X400	6,95	0,9	6,65	3,45	43,0	R A07.R L A07.L

Bestellbeispiel // Order example: **A07.0035.30.72.20 YER X800** (R = Rechte Ausführung // Right hand version, X800 = Schneidstoff // Grade)

Herstellen und Ausdrehen von Bohrungen

Schneideinsätze zum Herstellen und Ausdrehen von Bohrungen.
Kühlmittelzufuhr durch die Schneide für eine optimale Spanabfuhr.

Machining and Boring of Bores

Inserts for the machining and boring of bores.
With coolant supply through the insert for an optimum chip evacuation.

Schnittwerte (Start) // Cutting parameters (start)	
f	Vc
0,02 mm/U	Seite/Page 429

Passende Klemmhalter auf Seite // Suitable toolholders on page
33, 34, 35, 36, 37, 38, 41, 42, 43,
44, 45, 46, 47, 49, 50, 51, 52, 53,
54, 55, 59, 67, 68, 69

SP

HM

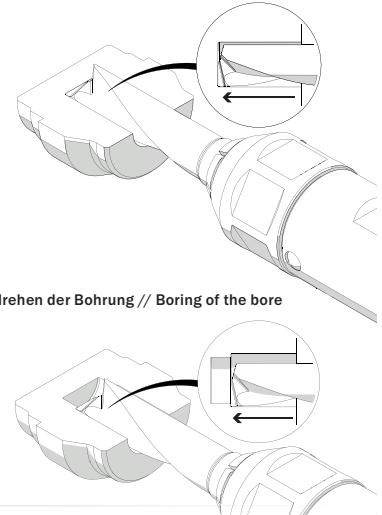
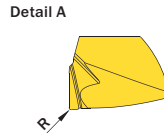
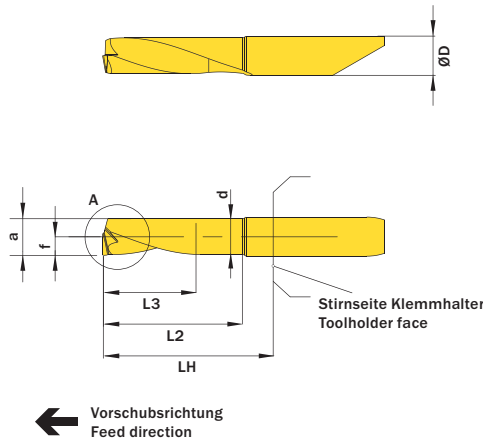
R

Legende
Legend

139

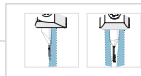
Scan QR-Code Oder besuchen Sie // Or Visit www.simtek.info/cp/1260

1 Herstellen der Bohrung // Machining of the bore



2 Ausdrehen der Bohrung // Boring of the bore

Abbildung zeigt / Drawing shows: A07.DB34.25.70.20 YR



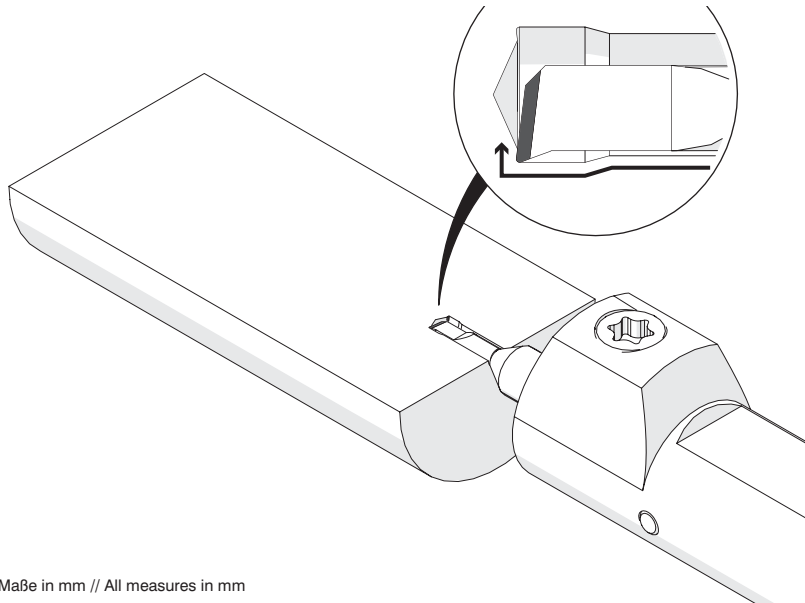
Mehr Informationen zur Kühlmittelzufuhr finden Sie auf Seite 22
Additional information about through coolant supply on page 22

ØD	f	L2	R	Kühlmittelzufuhr Through coolant supply	Artikelnummer Part number	Webcode www.simtek.com/webcode	Unsere erste Wahl Our first choice	a	d	ØDCMIN	ØDCMAX	L3 (Max. Bohrungstiefe) L3 (max. depth of bore)	LH	Connectcode www.simtek.com/code
mm	mm	mm	mm				P K M N S	mm	mm	mm	mm	mm	mm	
▼ ØDCMAX = 4,0 mm														
4,0	1,85	15,2	0,15	+	A04.DB19.15.40.15 YR	A04Y	X800 X400	3,55	3,4	3,7	4,0	10,0	18,0	A04T
4,0	1,85	15,2	0,2	+	A04.DB19.15.40.20 YR	A038	X800 X400	3,55	3,4	3,7	4,0	10,0	18,0	A04T
4,0	1,85	20,3	0,2	+	A04.DB19.20.40.20 YR	A039	X800 X400	3,55	3,4	3,7	4,0	15,0	23,0	A04T
▼ ØDCMAX = 5,0 mm														
5,0	2,35	15,2	0,2	+	A05.DB24.15.50.20 YR	A031	X800 X400	4,55	4,4	4,7	5,0	10,0	18,0	A05T
5,0	2,35	20,3	0,2	+	A05.DB24.20.50.20 YR	A032	X800 X400	4,55	4,4	4,7	5,0	15,0	23,0	A05T
5,0	2,35	25,4	0,2	+	A05.DB24.25.50.20 YR	A04K	X800 X400	4,55	4,4	4,7	5,0	20,0	28,0	A05T
▼ ØDCMAX = 6,0 mm														
6,0	2,85	15,2	0,2	+	A06.DB29.15.60.20 YR	A033	X800 X400	5,55	5,4	5,7	6,0	10,0	18,0	A06T
6,0	2,85	20,3	0,2	+	A06.DB29.20.60.20 YR	A034	X800 X400	5,55	5,4	5,7	6,0	15,0	23,0	A06T
6,0	2,85	25,4	0,2	+	A06.DB29.25.60.20 YR	A04H	X800 X400	5,55	5,4	5,7	6,0	20,0	28,0	A06T
6,0	2,85	30,5	0,2	+	A06.DB29.30.60.20 YR	A04J	X800 X400	5,55	5,4	5,7	6,0	25,0	33,0	A06T
▼ ØDCMAX = 7,0 mm														
7,0	3,35	20,3	0,2	+	A07.DB34.20.70.20 YR	A035	X800 X400	6,55	6,4	6,7	7,0	15,0	23,0	A07T
7,0	3,35	25,4	0,2	+	A07.DB34.25.70.20 YR	A036	X800 X400	6,55	6,4	6,7	7,0	20,0	28,0	A07T
7,0	3,35	30,5	0,2	+	A07.DB34.30.70.20 YR	A037	X800 X400	6,55	6,4	6,7	7,0	25,0	33,0	A07T
▼ ØDCMAX = 8,0 mm														
8,0	3,85	20,3	0,2	+	A08.DB39.20.80.20 YR	A06W	X800 X400	7,55	7,4	7,7	8,0	15,0	23,0	A08T
8,0	3,85	25,4	0,2	+	A08.DB39.25.80.20 YR	A04F	X800 X400	7,55	7,4	7,7	8,0	20,0	28,0	A08T
8,0	3,85	30,5	0,2	+	A08.DB39.30.80.20 YR	A04G	X800 X400	7,55	7,4	7,7	8,0	25,0	33,0	A08T

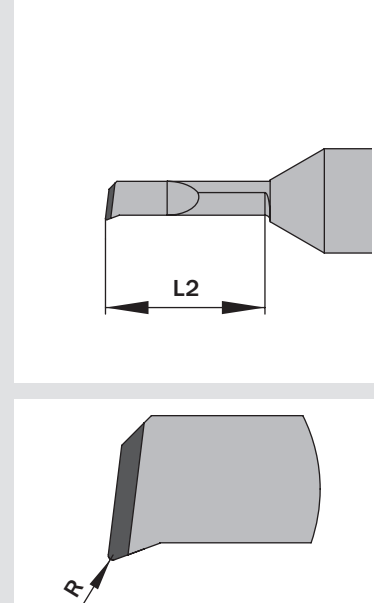
Bestellbeispiel // Order example: **A06.DB29.15.60.20 YR X800** (R = Rechte Ausführung // Right hand version, X800 = Schneidstoff // Grade)

simturn AX
simturn DX
simturn PX
simturn H2
simturn K2
simturn C4
simturn GX
simturn E3
simturn E12
simturn FX
simturn Decolletage
simturn OA
Index

Standardwerkzeuge // Standard Tools

Ausdrehen, Hartbearbeitung
Boring, Hard Part Turning

Alle Maße in mm // All measures in mm



Artikelnummer Part number	ØDmin (Min. Bohrung) ØDmin (min. bore)	L2	R	siehe Seite see Page
A04.1804.04.10.10 YUR	1,0	4,0	0,1	89
A04.1C04.04.10.10 YUR/L	1,0	4,1	0,1	89
A04.1804.06.10.10 YUR	1,0	6,0	0,1	89
A04.1C04.06.10.10 YUR/L	1,0	6,1	0,1	89
A04.1804.08.10.10 YUR	1,0	8,1	0,1	89
A04.1C04.08.10.10 YUR/L	1,0	8,1	0,1	89
A04.1805.04.12.10 YUR	1,2	5,1	0,1	89
A04.1C05.04.12.10 YUR/L	1,2	5,1	0,1	89
A04.1805.07.12.10 YUR	1,2	7,1	0,1	89
A04.1C05.07.12.10 YUR/L	1,2	7,1	0,1	89
A04.1805.09.12.10 YUR	1,2	9,1	0,1	89
A04.1C05.09.12.10 YUR/L	1,2	9,1	0,1	89
A04.1806.06.14.10 YUR	1,4	6,1	0,1	89
A04.1C06.06.14.10 YUR/L	1,4	6,1	0,1	89
A04.1806.10.14.10 YUR	1,4	10,2	0,1	89
A04.1C06.10.14.10 YUR/L	1,4	10,2	0,1	89
A04.1812.10.27.15 YUR/L	2,7	10,2	0,15	91
A04.1C12.10.27.15 YUR/L	2,7	10,2	0,15	91
A04.1812.15.27.15 YUR/L	2,7	15,2	0,15	91
A04.1C12.15.27.15 YUR/L	2,7	15,2	0,15	91
A04.1814.15.30.15 YUR	3,0	15,2	0,15	91
A04.1C14.15.30.15 YUR/L	3,0	15,2	0,15	91
A04.1814.20.30.15 YUR	3,0	20,3	0,15	91
A04.1C14.20.30.15 YUR/L	3,0	20,3	0,15	91
A04.1815.10.32.15 YUR/L	3,2	10,2	0,15	91
A04.1C15.10.32.15 YUR/L	3,2	10,2	0,15	91
A04.1815.15.32.15 YUR/L	3,2	15,2	0,15	91
A04.1C15.15.32.15 YUR/L	3,2	15,2	0,15	91
A04.1815.20.32.15 YUR/L	3,2	20,3	0,15	91
A04.1C15.20.32.15 YUR/L	3,2	20,3	0,15	91
A04.1817.10.37.15 YUR	3,7	10,2	0,15	92
A04.1C17.10.37.15 YUR/L	3,7	10,2	0,15	92
A04.1817.15.37.15 YUR/L	3,7	15,2	0,15	92
A04.1C17.15.37.15 YUR/L	3,7	15,2	0,15	92
A04.1817.20.37.15 YUR	3,7	20,3	0,15	92
A04.1C17.20.37.15 YUR/L	3,7	20,3	0,15	92
A04.1817.25.37.10 YUR	3,7	25,4	0,1	92
A04.1C17.25.37.10 YUR/L	3,7	25,4	0,1	92
A04.1817.25.37.15 YUR	3,7	25,4	0,15	92
A04.1C17.25.37.15 YUR/L	3,7	25,4	0,15	92
A04.1820.10.42.15 YUR/L	4,2	10,2	0,15	92

Artikelnummer Part number	ØDmin (Min. Bohrung) ØDmin (min. bore)	L2	R	siehe Seite see Page
A04.2020.10.42.15 YUR/L	4,2	10,2	0,15	92
A04.1820.15.42.15 YUR/L	4,2	15,2	0,15	92
A04.1820.20.42.15 YUR/L	4,2	20,3	0,15	92
A04.1820.25.42.15 YUR/L	4,2	25,4	0,15	92
A05.1825.10.52.20 YUR/L	5,2	10,2	0,2	93
A05.1825.15.52.20 YUR/L	5,2	15,2	0,2	93
A05.1825.20.52.20 YUR/L	5,2	20,3	0,2	93
A05.1825.25.52.20 YUR/L	5,2	25,4	0,2	93
A05.1825.30.52.20 YUR/L	5,2	30,5	0,2	93
A05.1825.40.52.20 YUR/L	5,2	40,6	0,2	93
A06.1830.15.62.20 YUR/L	6,2	15,2	0,2	93
A06.1830.20.62.20 YUR/L	6,2	20,3	0,2	93
A06.1830.25.62.20 YUR/L	6,2	25,4	0,2	93
A06.1830.30.62.20 YUR/L	6,2	30,5	0,2	93
A06.1830.35.62.20 YUR/L	6,2	35,6	0,2	93
A06.1830.40.62.20 YUR/L	6,2	40,6	0,2	93
A07.1835.25.72.20 YUR/L	7,2	25,4	0,2	93
A07.1835.30.72.20 YUR/L	7,2	30,5	0,2	93
A07.1835.35.72.20 YUR/L	7,2	35,6	0,2	93
A07.1835.40.72.20 YUR/L	7,2	40,6	0,2	93
A07.1835.50.72.20 YUR/L	7,2	50,8	0,2	93

Ausdrehen, Hartbearbeitung

In Verbindung mit einem CBN-Schneidstoff besonders geeignet für die Hartbearbeitung ab Bohrungsdurchmesser 1,0 mm.

Boring, Hard Part Turning

First choice for hard part turning applications in bores as of bore diameter 1,0 mm in combination with our CBN grades.

Schnittwerte (Start) // Cutting parameters (start)

f	Vc
0,02 mm/U	Seite/Page 429

Passende Klemmhalter auf Seite // Suitable toolholders on page

26, 31, 32, 33, 34, 40, 41, 43, 50, 51, 53, 55, 56, 57, 60, 62, 63, 65, 66, 67, 68, 69

Vergleichbare Werkzeuge auf Seite // Similar tools on page

88

SP

CBN

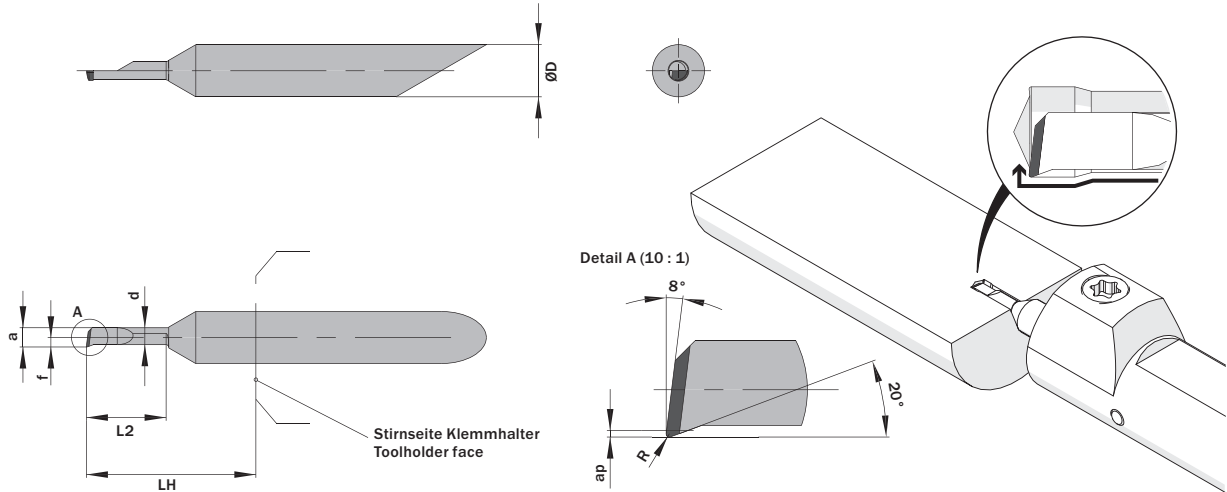
R

Legende
Legend

139

Scan
QR-Code

Oder besuchen Sie // Or Visit
www.simtek.info/cp/1051



Mehr Informationen zur Kühlmittelzufuhr finden Sie auf Seite 22
Additional information about through coolant supply on page 22

ØD	L2	ØDmin (Min. Bohrung) ØDmin (min. bore)	R	Kühlmittelzufuhr Through coolant supply	Artikelnummer Part number	Webcode www.simtek.com/webcode	Unsere erste Wahl Our first choice	a	ap	d	f	LH	Connectcode www.simtek.com/code			
														H		
▼ ØDmin (Min. Bohrung) // ØDmin (min. bore) = 1,0 mm																
4,0	4,0	1,0	0,1	-	A04.1804.04.10.10 YUR	A53N	CBN	0,95	0,05	0,75	0,45	13,0	A04.R			new
4,0	4,1	1,0	0,1	+	A04.1C04.04.10.10 YUR/L	R ADBK L AJ4P	CBN	0,95	0,05	0,75	1,95	13,0	R A04C.R L A04C.L			upd
4,0	6,0	1,0	0,1	-	A04.1804.06.10.10 YUR	A53K	CBN	0,95	0,05	0,75	0,45	13,0	A04.R			new
4,0	6,1	1,0	0,1	+	A04.1C04.06.10.10 YUR/L	R ADCN L APKW	CBN	0,95	0,05	0,75	1,95	13,0	R A04C.R L A04C.L			upd
4,0	8,1	1,0	0,1	-	A04.1804.08.10.10 YUR	A53Q	CBN	0,95	0,05	0,75	0,45	13,0	A04.R			new
4,0	8,1	1,0	0,1	+	A04.1C04.08.10.10 YUR/L	R AKCE L ACV1	CBN	0,95	0,05	0,75	1,95	13,0	R A04C.R L A04C.L			upd
▼ ØDmin (Min. Bohrung) // ØDmin (min. bore) = 1,2 mm																
4,0	5,1	1,2	0,1	-	A04.1805.04.12.10 YUR	A53T	CBN	1,1	0,06	0,85	0,55	13,0	A04.R			new
4,0	5,1	1,2	0,1	+	A04.1C05.04.12.10 YUR/L	R AW3Y L AW3X	CBN	1,1	0,06	0,85	1,95	13,0	R A04C.R L A04C.L			upd
4,0	7,1	1,2	0,1	-	A04.1805.07.12.10 YUR	A53V	CBN	1,1	0,06	0,85	0,55	13,0	A04.R			new
4,0	7,1	1,2	0,1	+	A04.1C05.07.12.10 YUR/L	R AW30 L AW3Z	CBN	1,1	0,06	0,85	1,95	13,0	R A04C.R L A04C.L			upd
4,0	9,1	1,2	0,1	-	A04.1805.09.12.10 YUR	A53X	CBN	1,1	0,06	0,85	0,55	13,0	A04.R			new
4,0	9,1	1,2	0,1	+	A04.1C05.09.12.10 YUR/L	R AW32 L AW31	CBN	1,1	0,06	0,85	1,95	13,0	R A04C.R L A04C.L			upd
▼ ØDmin (Min. Bohrung) // ØDmin (min. bore) = 1,4 mm																
4,0	6,1	1,4	0,1	-	A04.1806.06.14.10 YUR	A53Z	CBN	1,25	0,07	0,95	0,6	13,0	A04.R			new
4,0	6,1	1,4	0,1	+	A04.1C06.06.14.10 YUR/L	R AW34 L AW33	CBN	1,25	0,07	0,95	1,95	13,0	R A04C.R L A04C.L			upd
4,0	10,2	1,4	0,1	-	A04.1806.10.14.10 YUR	A531	CBN	1,25	0,07	0,95	0,6	13,0	A04.R			new
4,0	10,2	1,4	0,1	+	A04.1C06.10.14.10 YUR/L	R AW36 L AW35	CBN	1,25	0,07	0,95	1,95	13,0	R A04C.R L A04C.L			upd

Verwandte Werkzeuge finden Sie auch auf der folgenden Seite!
Related items can be found on the following page as well!

Fortgesetzte Tabelle
Continued Table

Bestellbeispiel // Order example: A04.1C06.06.14.10 YUR GT91 (R = Rechte Ausführung // Right hand version, GT91 = Schneidstoff // Grade)

Ausdrehen, Hartbearbeitung

In Verbindung mit einem CBN-Schneidstoff besonders geeignet für die Hartbearbeitung ab Bohrungsdurchmesser 1,7 mm.

Boring, Hard Part Turning

First choice for hard part turning applications in bores as of bore diameter 1,7 mm in combination with our CBN grades.

Schnittwerte (Start) // Cutting parameters (start)

f	Vc
0,02 mm/U	Seite/Page 429

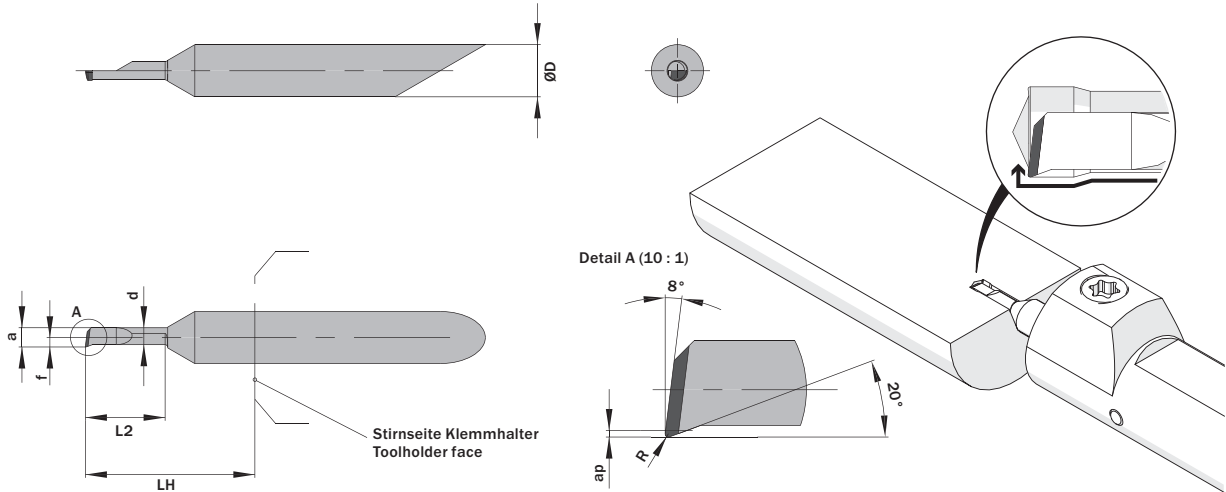
Passende Klemmhalter auf Seite // Suitable toolholders on page

26, 31, 32, 33, 34, 40, 41, 43, 50,
51, 53, 55, 56, 57, 60, 62, 63, 65,
66, 67, 68, 69

SP CBN R

Legende Legend **139**

Scan QR-Code Oder besuchen Sie // Or Visit www.simtek.info/cp/1334



Mehr Informationen zur Kühlmittelzufuhr finden Sie auf Seite 22
Additional information about through coolant supply on page 22

ØD	L2	ØDmin (Min. Bohrung) ØDmin (min. bore)	R	Kühlmittelzufuhr Through coolant supply	Artikelnummer Part number	Webcode www.simtek.com/webcode	Unsere erste Wahl Our first choice	a	ap	d	f	LH	Connectcode www.simtek.com/code
mm	mm	mm	mm				H	mm	mm	mm	mm	mm	

Fortgesetzte Tabelle Continued Table **Verwandte Werkzeuge finden Sie auch auf der vorhergehenden Seite!**
Related items can be found on the previous page as well!

▼ ØDmin (Min. Bohrung) // ØDmin (min. bore) = 1,7 mm													
4,0	6,1	1,7	0,1	-	A04.1807.06.17.10 YUR/L	R AG1U L AGGP	CBN	1,45	0,08	1,05	0,7	13,0	R A04.R L A04.L
4,0	6,1	1,7	0,1	+	A04.1C07.06.17.10 YUR/L	R AJ7P L AN6Q	CBN	1,45	0,08	1,05	1,95	13,0	R A04C.R L A04C.L
4,0	9,1	1,7	0,1	-	A04.1807.09.17.10 YUR	A533	CBN	1,45	0,08	1,05	0,7	13,0	A04.R new
4,0	9,1	1,7	0,1	+	A04.1C07.09.17.10 YUR/L	R ANØV L A12Ø	CBN	1,45	0,08	1,05	1,95	13,0	R A04C.R L A04C.L
▼ ØDmin (Min. Bohrung) // ØDmin (min. bore) = 1,9 mm													
4,0	9,1	1,9	0,1	-	A04.1808.09.19.10 YUR	A535	CBN	1,65	0,1	1,25	0,85	13,0	A04.R new
4,0	9,1	1,9	0,1	+	A04.1C08.09.19.10 YUR/L	R AW38 L AW37	CBN	1,65	0,1	1,25	1,95	13,0	R A04C.R L A04C.L
4,0	12,2	1,9	0,1	-	A04.1808.12.19.10 YUR	A537	CBN	1,65	0,1	1,25	0,85	18,0	A04.R new
4,0	12,2	1,9	0,1	+	A04.1C08.12.19.10 YUR/L	R AW4A L AW39	CBN	1,65	0,1	1,25	1,95	18,0	R A04C.R L A04C.L
▼ ØDmin (Min. Bohrung) // ØDmin (min. bore) = 2,2 mm													
4,0	6,0	2,2	0,1	●	A04.1810.06.22.10 YUR	A539	CBN	1,95	0,11	1,55	0,95	13,0	A04.R new
4,0	6,1	2,2	0,1	+	A04.1C10.06.22.10 YUR/L	R AAPX L AJMG	CBN	1,95	0,11	1,55	1,95	13,0	R A04C.R L A04C.L
4,0	9,1	2,2	0,1	●	A04.1810.09.22.10 YUR/L	R AHS2 L AJFD	CBN	1,95	0,11	1,55	0,95	13,0	R A04.R L A04.L
4,0	9,1	2,2	0,1	+	A04.1C10.09.22.10 YUR/L	R ANZ8 L A1T5	CBN	1,95	0,11	1,55	1,95	13,0	R A04C.R L A04C.L
4,0	13,2	2,2	0,1	●	A04.1810.13.22.10 YUR	A54B	CBN	1,95	0,11	1,55	0,95	18,0	A04.R new
4,0	13,2	2,2	0,1	+	A04.1C10.13.22.10 YUR/L	R ABTM L AFZ1	CBN	1,95	0,11	1,55	1,95	18,0	R A04C.R L A04C.L

Verwandte Werkzeuge finden Sie auch auf der folgenden Seite!
Related items can be found on the following page as well!

Fortgesetzte Tabelle Continued Table

Bestellbeispiel // Order example: A04.1C10.06.22.10 YUR GT91 (R = Rechte Ausführung // Right hand version, GT91 = Schneidstoff // Grade)

Ausdrehen, Hartbearbeitung und WIPER-Geometrie

In Verbindung mit einem CBN-Schneidstoff besonders geeignet für die Hartbearbeitung ab Bohrungsdurchmesser 2,7 mm.

Boring, Hard Part Turning plus WIPER-Geometry

First choice for hard part turning applications in bores as of bore diameter 2,7 mm in combination with our CBN grades.

Schnittwerte (Start) // Cutting parameters (start)	
f 0,02 mm/U	Vc Seite/Page 429

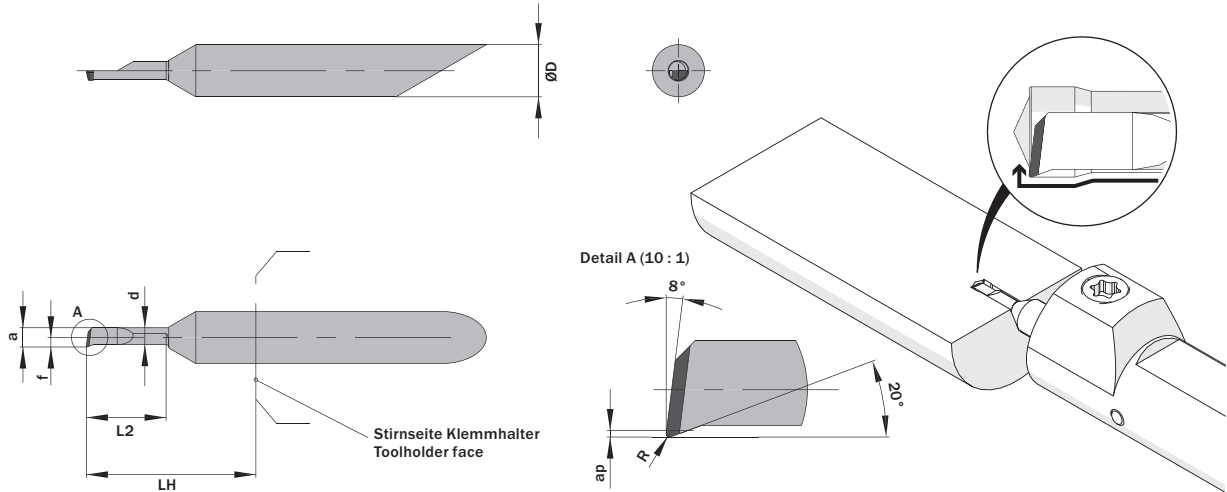
Passende Klemmhalter auf Seite // Suitable toolholders on page 26, 31, 32, 33, 34, 40, 41, 43, 50, 51, 53, 55, 56, 57, 60, 62, 63, 65, 66, 67, 68, 69

Vergleichbare Werkzeuge auf Seite // Similar tools on page 88

SP
CBN **R**

Legende Legend **139**

Scan QR-Code Oder besuchen Sie // Or visit www.simtek.info/cp/1052



Mehr Informationen zur Kühlmittelzufuhr finden Sie auf Seite 22
Additional information about through coolant supply on page 22

ØD	L2	ØDmin (Min. Bohrung) ØDmin (min. bore)	R	Kühlmittelzufuhr Through coolant supply	Artikelnummer Part number	Webcode www.simtek.com/webcode	Unsere erste Wahl Our first choice	a	ap	d	f	LH	Connectcode www.simtek.com/code
mm	mm	mm	mm				H	mm	mm	mm	mm	mm	

Fortgesetzte Tabelle Continued Table **Verwandte Werkzeuge finden Sie auch auf der vorhergehenden Seite!**
Related items can be found on the previous page as well!

▼ ØDmin (Min. Bohrung) // ØDmin (min. bore) = 2,7 mm													
4,0	10,2	2,7	0,15	-	A04.1812.10.27.15 YUR/L	R AKDS L ADHA	CBN	2,45	0,13	2,05	1,2	13,0	R A04.R L A04.L
4,0	10,2	2,7	0,15	+	A04.1C12.10.27.15 YUR/L	R APSV L ACU3	CBN	2,45	0,13	2,05	1,95	13,0	R A04C.R L A04C.L
4,0	15,2	2,7	0,15	-	A04.1812.15.27.15 YUR/L	R AWK9 L AW4X	CBN	2,45	0,13	2,05	1,2	18,0	R A04.R L A04.L
4,0	15,2	2,7	0,15	+	A04.1C12.15.27.15 YUR/L	R AAQ6 L AG95	CBN	2,45	0,13	2,05	1,95	18,0	R A04C.R L A04C.L
▼ ØDmin (Min. Bohrung) // ØDmin (min. bore) = 3,0 mm													
4,0	15,2	3,0	0,15	-	A04.1814.15.30.15 YUR	A54D	CBN	2,75	0,1	2,35	1,35	23,0	A04.R new
4,0	15,2	3,0	0,15	+	A04.1C14.15.30.15 YUR/L	R AW4C L AW4B	CBN	2,75	0,1	2,35	1,95	23,0	R A04C.R L A04C.L
4,0	20,3	3,0	0,15	-	A04.1814.20.30.15 YUR	A54F	CBN	2,75	0,1	2,35	1,35	23,0	A04.R new
4,0	20,3	3,0	0,15	+	A04.1C14.20.30.15 YUR/L	R AGYZ L ANDP	CBN	2,75	0,1	2,35	1,95	23,0	R A04C.R L A04C.L
▼ ØDmin (Min. Bohrung) // ØDmin (min. bore) = 3,2 mm													
4,0	10,2	3,2	0,15	-	A04.1815.10.32.15 YUR/L	R ADD4 L AB88	CBN	2,95	0,16	2,55	1,45	13,0	R A04.R L A04.L
4,0	10,2	3,2	0,15	+	A04.1C15.10.32.15 YUR/L	R APBY L ABA4	CBN	2,95	0,16	2,55	1,95	13,0	R A04C.R L A04C.L
4,0	15,2	3,2	0,15	-	A04.1815.15.32.15 YUR/L	R AGGV L AJV6	CBN	2,95	0,16	2,55	1,45	18,0	R A04.R L A04.L
4,0	15,2	3,2	0,15	+	A04.1C15.15.32.15 YUR/L	R APHK L AFG3	CBN	2,95	0,16	2,55	1,95	18,0	R A04C.R L A04C.L
4,0	20,3	3,2	0,15	-	A04.1815.20.32.15 YUR/L	R AQ5Q L ATT2	CBN	2,95	0,16	2,55	1,45	23,0	R A04.R L A04.L
4,0	20,3	3,2	0,15	+	A04.1C15.20.32.15 YUR/L	R AHC2 L AD09	CBN	2,95	0,16	2,55	1,95	23,0	R A04C.R L A04C.L

Verwandte Werkzeuge finden Sie auch auf der folgenden Seite!
Related items can be found on the following page as well!

Fortgesetzte Tabelle Continued Table

Bestellbeispiel // Order example: **A04.1815.10.32.15 YUR CBN8** (R = Rechte Ausführung // Right hand version, CBN8 = Schneidstoff // Grade)

Ausdrehen, Hartbearbeitung und WIPER Geometrie

In Verbindung mit einem CBN-Schneidstoff besonders geeignet für die Hartbearbeitung ab Bohrungsdurchmesser 4,2 mm.

Boring, Hard Part Turning plus WIPER-Geometry

First choice for hard part turning applications in bores as of bore diameter 4,2 mm in combination with our CBN grades.

Schnittwerte (Start) // Cutting parameters (start)

f	Vc
0,02 mm/U	Seite/Page 429

Passende Klemmhalter auf Seite // Suitable toolholders on page

26, 31, 32, 33, 34, 40, 41, 43, 50, 51, 53, 55, 56, 57, 60, 62, 63, 65, 66, 67, 68, 69

Vergleichbare Werkzeuge auf Seite // Similar tools on page

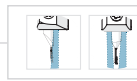
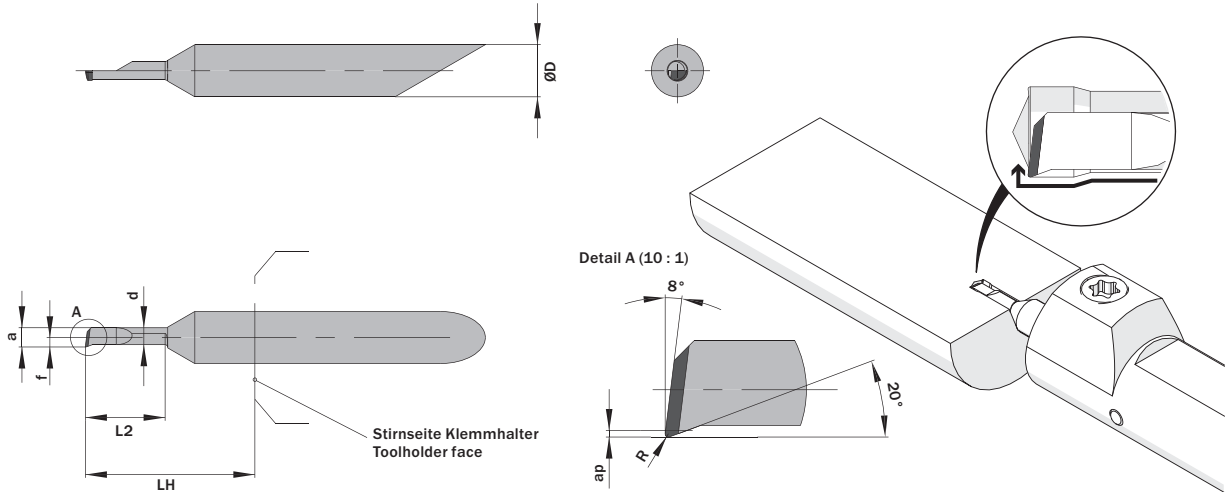
88



Legende Legend 139

Scan QR-Code

Oder besuchen Sie // Or Visit www.simtek.info/cp/1053



Mehr Informationen zur Kühlmittelzufuhr finden Sie auf Seite 22
Additional information about through coolant supply on page 22

ØD	L2	ØDmin (Min. Bohrung) ØDmin (min. bore)	R	Kühlmittelzufuhr Through coolant supply	Artikelnummer Part number	Webcode www.simtek.com/webcode	Unsere erste Wahl Our first choice	a	ap	d	f	LH	Connectcode www.simtek.com/code
mm	mm	mm	mm				H	mm	mm	mm	mm	mm	

Fortgesetzte Tabelle
Continued Table

Verwandte Werkzeuge finden Sie auch auf der vorhergehenden Seite!
Related items can be found on the previous page as well!

▼ ØDmin (Min. Bohrung) // ØDmin (min. bore) = 3,7 mm													
4,0	10,2	3,7	0,15	-	A04.1817.10.37.15 YUR	A54H	CBN	3,45	0,18	3,05	1,7	13,0	A04.R new
4,0	10,2	3,7	0,15	+	A04.1C17.10.37.15 YUR/L	R AF4J L AHZV	CBN	3,45	0,18	3,05	1,95	13,0	R A04C.R L A04C.L
4,0	15,2	3,7	0,15	-	A04.1817.15.37.15 YUR/L	R ABVW L AFNM	CBN	3,45	0,18	3,05	1,7	18,0	R A04.R L A04.L
4,0	15,2	3,7	0,15	+	A04.1C17.15.37.15 YUR/L	R AJ9Y L ABDU	CBN	3,45	0,18	3,05	1,95	18,0	R A04C.R L A04C.L
4,0	20,3	3,7	0,15	-	A04.1817.20.37.15 YUR	A54K	CBN	3,45	0,18	3,05	1,7	23,0	A04.R new
4,0	20,3	3,7	0,15	+	A04.1C17.20.37.15 YUR/L	R AHN6 L ABFZ	CBN	3,45	0,18	3,05	1,95	23,0	R A04C.R L A04C.L
4,0	25,4	3,7	0,1	-	A04.1817.25.37.10 YUR	A54N	CBN	3,45	0,18	3,05	1,7	28,0	A04.R new
4,0	25,4	3,7	0,1	+	A04.1C17.25.37.10 YUR/L	R AK2Z L AGKZ	CBN	3,45	0,18	3,05	1,95	28,0	R A04C.R L A04C.L
4,0	25,4	3,7	0,15	-	A04.1817.25.37.15 YUR	A54Q	CBN	3,45	0,18	3,05	1,7	28,0	A04.R new
4,0	25,4	3,7	0,15	+	A04.1C17.25.37.15 YUR/L	R AM56 L ATWA	CBN	3,45	0,18	3,05	1,95	28,0	R A04C.R L A04C.L
▼ ØDmin (Min. Bohrung) // ØDmin (min. bore) = 4,2 mm													
4,0	10,2	4,2	0,15	+	A04.1820.10.42.15 YUR/L	R AH9U L AH6F	CBN	3,95	0,21	3,45	1,95	13,0	R A04C.R L A04C.L
4,0	15,2	4,2	0,15	+	A04.1820.15.42.15 YUR/L	R AJ94 L AMC8	CBN	3,95	0,21	3,45	1,95	18,0	R A04C.R L A04C.L
4,0	20,3	4,2	0,15	+	A04.1820.20.42.15 YUR/L	R AHVV L ABZS	CBN	3,95	0,21	3,45	1,95	23,0	R A04C.R L A04C.L
4,0	25,4	4,2	0,15	+	A04.1820.25.42.15 YUR/L	R AKJE L ACN3	CBN	3,95	0,21	3,45	1,95	28,0	R A04C.R L A04C.L
4,0	10,2	4,2	0,15	+	A04.2020.10.42.15 YUR/L	R AQQC L A4X3	CBN	3,95	0,21	3,45	1,95	13,0	R A04.R L A04.L new

Verwandte Werkzeuge finden Sie auch auf der folgenden Seite!
Related items can be found on the following page as well!

Fortgesetzte Tabelle
Continued Table

Bestellbeispiel // Order example: A04.1817.15.37.15 YUR CBN8 (R = Rechte Ausführung // Right hand version, CBN8 = Schneidstoff // Grade)

Ausdrehen, Hartbearbeitung und WIPER-Geometrie

In Verbindung mit einem CBN-Schneidstoff besonders geeignet für die Hartbearbeitung ab Bohrungsdurchmesser 6,2 mm.

Boring, Hard Part Turning plus WIPER-Geometry

First choice for hard part turning applications in bores as of bore diameter 6,2 mm in combination with our CBN grades.

Schnittwerte (Start) // Cutting parameters (start)

f	Vc
0,02 mm/U	Seite/Page 429

Passende Klemmhalter auf Seite // Suitable toolholders on page

27, 28, 29, 31, 33, 35, 36, 37, 41, 42, 44, 45, 46, 50, 51, 52, 53, 54, 55, 56, 57, 58, 61, 62, 63, 64, 65, 66, 67, 68, 69

Vergleichbare Werkzeuge auf Seite // Similar tools on page

88

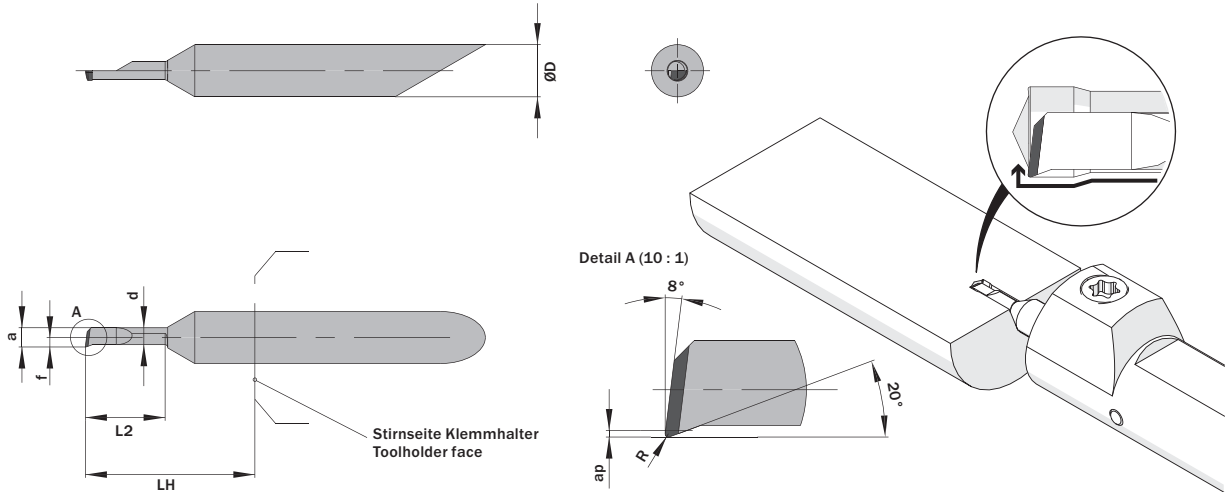
SP

CBN

R

Legende Legend **139**

Scan QR-Code Oder besuchen Sie // Or Visit www.simtek.info/cp/1063



Mehr Informationen zur Kühlmittelzufuhr finden Sie auf Seite 22
Additional information about through coolant supply on page 22

ØD	L2	ØDmin (Min. Bohrung) ØDmin (min. bore)	R	Kühlmittelzufuhr Through coolant supply	Artikelnummer Part number	Webcode www.simtek.com/webcode	Unsere erste Wahl Our first choice	a	ap	d	f	LH	Connectcode www.simtek.com/code
mm	mm	mm	mm				H	mm	mm	mm	mm	mm	

Fortgesetzte Tabelle Continued Table **Verwandte Werkzeuge finden Sie auch auf der vorhergehenden Seite!**
Related items can be found on the previous page as well!

▼ ØDmin (Min. Bohrung) // ØDmin (min. bore) = 5,2 mm

5,0	10,2	5,2	0,2	+	A05.1825.10.52.20 YUR/L	R AH5 L AHM	CBN	4,95	0,26	4,25	2,45	13,0	R A05.R L A05.L
5,0	15,2	5,2	0,2	+	A05.1825.15.52.20 YUR/L	R AD1K L AE8S	CBN	4,95	0,26	4,25	2,45	18,0	R A05.R L A05.L
5,0	20,3	5,2	0,2	+	A05.1825.20.52.20 YUR/L	R AHAX L AM28	CBN	4,95	0,26	4,25	2,45	23,0	R A05.R L A05.L
5,0	25,4	5,2	0,2	+	A05.1825.25.52.20 YUR/L	R AA87 L ADPG	CBN	4,95	0,26	4,25	2,45	28,0	R A05.R L A05.L
5,0	30,5	5,2	0,2	+	A05.1825.30.52.20 YUR/L	R ADNS L ABNV	CBN	4,95	0,26	4,25	2,45	33,0	R A05.R L A05.L
5,0	40,6	5,2	0,2	+	A05.1825.40.52.20 YUR/L	R AJBN L AF1T	CBN	4,95	0,26	4,25	2,45	43,0	R A05.R L A05.L

▼ ØDmin (Min. Bohrung) // ØDmin (min. bore) = 6,2 mm

6,0	15,2	6,2	0,2	+	A06.1830.15.62.20 YUR/L	R ADEW L APKD	CBN	5,95	0,31	5,25	2,95	18,0	R A06.R L A06.L
6,0	20,3	6,2	0,2	+	A06.1830.20.62.20 YUR/L	R AEWG L AD88	CBN	5,95	0,31	5,25	2,95	23,0	R A06.R L A06.L
6,0	25,4	6,2	0,2	+	A06.1830.25.62.20 YUR/L	R ACXE L AH4U	CBN	5,95	0,31	5,25	2,95	28,0	R A06.R L A06.L
6,0	30,5	6,2	0,2	+	A06.1830.30.62.20 YUR/L	R AEJ9 L AGTA	CBN	5,95	0,31	5,25	2,95	33,0	R A06.R L A06.L
6,0	35,6	6,2	0,2	+	A06.1830.35.62.20 YUR/L	R ANYT L ANN5	CBN	5,95	0,31	5,25	2,95	38,0	R A06.R L A06.L
6,0	40,6	6,2	0,2	+	A06.1830.40.62.20 YUR/L	R AJ2Z L AP2G	CBN	5,95	0,31	5,25	2,95	43,0	R A06.R L A06.L

▼ ØDmin (Min. Bohrung) // ØDmin (min. bore) = 7,2 mm

7,0	25,4	7,2	0,2	+	A07.1835.25.72.20 YUR/L	R ABD2 L AKEW	CBN	6,95	0,36	6,25	3,45	28,0	R A07.R L A07.L
7,0	30,5	7,2	0,2	+	A07.1835.30.72.20 YUR/L	R ACBJ L AJG9	CBN	6,95	0,36	6,25	3,45	33,0	R A07.R L A07.L
7,0	35,6	7,2	0,2	+	A07.1835.35.72.20 YUR/L	R ADK7 L AK9F	CBN	6,95	0,36	6,25	3,45	38,0	R A07.R L A07.L
7,0	40,6	7,2	0,2	+	A07.1835.40.72.20 YUR/L	R AK5S L AF7V	CBN	6,95	0,36	6,25	3,45	43,0	R A07.R L A07.L
7,0	50,8	7,2	0,2	+	A07.1835.50.72.20 YUR/L	R ADDS L AD9D	CBN	6,95	0,36	6,25	3,45	53,0	R A07.R L A07.L

Bestellbeispiel // Order example: **A05.1825.15.52.20 YUR X800** (R = Rechte Ausführung // Right hand version, X800 = Schneidstoff // Grade)

Ausdrehen

Mit stirnseitigem Freiwinkel von 20°. Geeignet ab Bohrungsdurchmesser 1,0 mm.

Boring

With 20° front side clearance angle. For use in bores as of minimum bore diameter 1,0 mm.

Schnittwerte (Start) // Cutting parameters (start)

f	Vc
0,02 mm/U	Seite/Page 429

Passende Klemmhalter auf Seite // Suitable toolholders on page
 26, 31, 32, 33, 34, 40, 41, 43, 50, 51, 53, 55, 56, 57, 60, 62, 63, 65, 66, 67, 68, 69

SP
HM
R

Legende
Legend **139**

Scan QR-Code Oder besuchen Sie // Or Visit www.simtek.info/cp/752

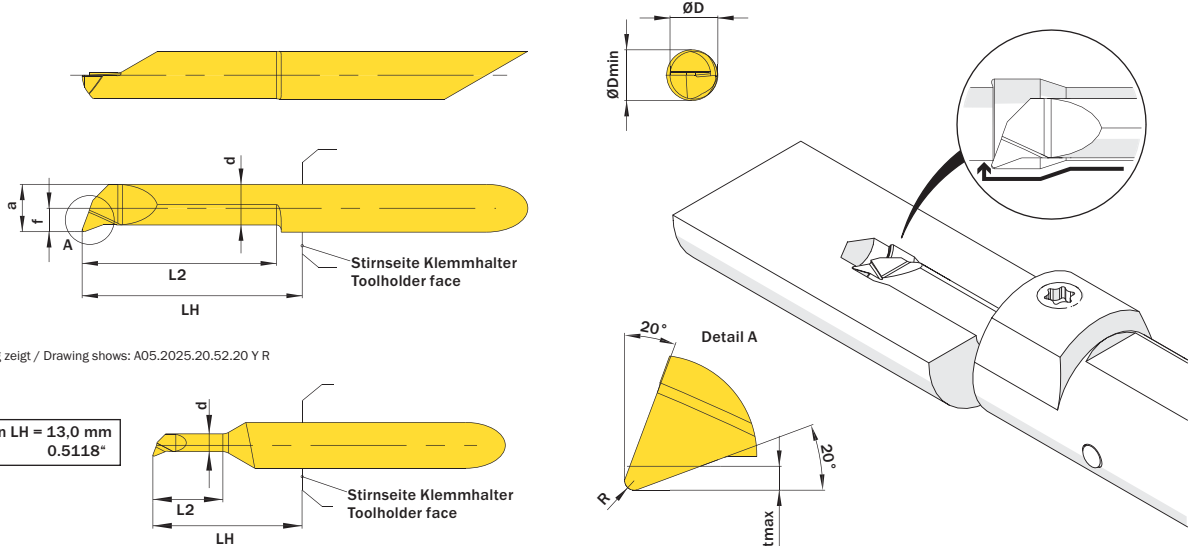


Abbildung zeigt / Drawing shows: A05.2025.20.52.20 Y R

Version LH = 13,0 mm
 0.5118"

Abbildung zeigt / Drawing shows: A04.2010.06.22.10 Y R

Mehr Informationen zur Kühlmittelzufuhr finden Sie auf Seite 22
 Additional information about through coolant supply on page 22

ØD	L2	ØDmin (Min. Bohrung) ØDmin (min. bore)	R	Kühlmittelzufuhr Through coolant supply	Artikelnummer Part number	Webcode www.simtek.com/webcode	Unsere erste Wahl Our first choice	a	d	f	LH	tmax	Connectcode www.simtek.com/code
mm	mm	mm	mm				P K M N S	mm	mm	mm	mm	mm	
▼ ØDmin (Min. Bohrung) // ØDmin (min. bore) = 1,0 mm													
4,0	4,1	1,0	0,1	+	A04.2C04.04.10.10 YR/L	R AW9Z L AXAU	X800 X400	0,95	0,65	1,95	13,0	0,1	R A04C.R L A04C.L
4,0	6,1	1,0	0,1	+	A04.2C04.06.10.10 YR/L	R AW90 L AXAV	X800 X400	0,95	0,65	1,95	13,0	0,1	R A04C.R L A04C.L
▼ ØDmin (Min. Bohrung) // ØDmin (min. bore) = 1,7 mm													
4,0	6,1	1,7	0,1	+	A04.2C07.06.17.10 YR/L	R AW91 L AXAW	X800 X400	1,45	1,05	1,95	13,0	0,2	R A04C.R L A04C.L
4,0	9,1	1,7	0,1	+	A04.2C07.09.17.10 YR/L	R AW92 L AXAX	X800 X400	1,45	1,05	1,95	13,0	0,2	R A04C.R L A04C.L
▼ ØDmin (Min. Bohrung) // ØDmin (min. bore) = 2,2 mm													
4,0	6,1	2,2	0,1	-	A04.2010.06.22.10 YR/L	R AMGH L ABMV	X800 X400	1,95	1,55	0,95	13,0	0,2	R A04.R L A04.L
4,0	6,1	2,2	0,1	+	A04.2C10.06.22.10 YR/L	R AXBJ L AXBT	X800 X400	1,95	1,55	1,95	13,0	0,2	R A04C.R L A04C.L
4,0	9,1	2,2	0,1	-	A04.2010.09.22.10 YR/L	R AFG4 L AMST	X800 X400	1,95	1,55	0,95	13,0	0,2	R A04.R L A04.L
4,0	9,1	2,2	0,1	+	A04.2C10.09.22.10 YR/L	R AXBK L AXBU	X800 X400	1,95	1,55	1,95	13,0	0,2	R A04C.R L A04C.L
▼ ØDmin (Min. Bohrung) // ØDmin (min. bore) = 2,7 mm													
4,0	10,2	2,7	0,15	-	A04.2012.10.27.15 YR/L	R ADW7 L AM7W	X800 X400	2,45	2,05	1,2	13,0	0,2	R A04.R L A04.L
4,0	10,2	2,7	0,15	+	A04.2C12.10.27.15 YR/L	R AXBM L AXBV	X800 X400	2,45	2,05	1,95	13,0	0,2	R A04C.R L A04C.L
4,0	15,2	2,7	0,15	-	A04.2012.15.27.15 YR/L	R AKSJ L AFC8	X800 X400	2,45	2,05	1,2	18,0	0,2	R A04.R L A04.L
4,0	15,2	2,7	0,15	+	A04.2C12.15.27.15 YR/L	R AXBN L AXBW	X800 X400	2,45	2,05	1,95	18,0	0,2	R A04C.R L A04C.L

Verwandte Werkzeuge finden Sie auch auf der folgenden Seite!
 Related Items can be found on the following page as well!

Fortgesetzte Tabelle
 Continued Table

Bestellbeispiel // Order example: A04.2010.06.22.10 YR X800 (R = Rechte Ausführung // Right hand version, X800 = Schneidstoff // Grade)

Ausdrehen

Mit stirnseitigem Freiwinkel von 20°. Geeignet ab Bohrungsdurchmesser 3,2 mm.

Boring

With 20° front side clearance angle. For use in bores as of minimum bore diameter 3,2 mm.

Schnittwerte (Start) // Cutting parameters (start)

f	Vc
0,02 mm/U	Seite/Page 429

Passende Klemmhalter auf Seite // Suitable toolholders on page

- 26, 27, 28, 29, 31, 32, 33, 34, 35,
- 36, 37, 40, 41, 42, 43, 44, 45, 46,
- 50, 51, 52, 53, 54, 55, 56, 57, 58,
- 60, 61, 62, 63, 64, 65, 66, 67, 68,
- 69



SP **HM** **R** Legende Legend 139

Scan QR-Code Oder besuchen Sie // Or Visit www.simtek.info/cp/1056

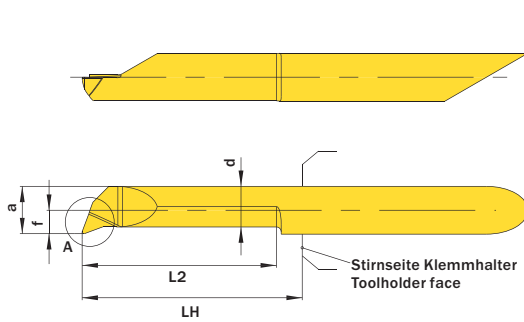


Abbildung zeigt / Drawing shows: A05.2025.20.52.20 Y R

Version LH = 13,0 mm
0.5118"

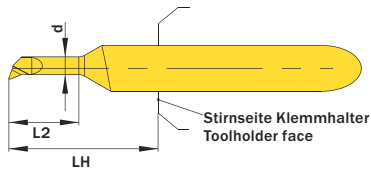
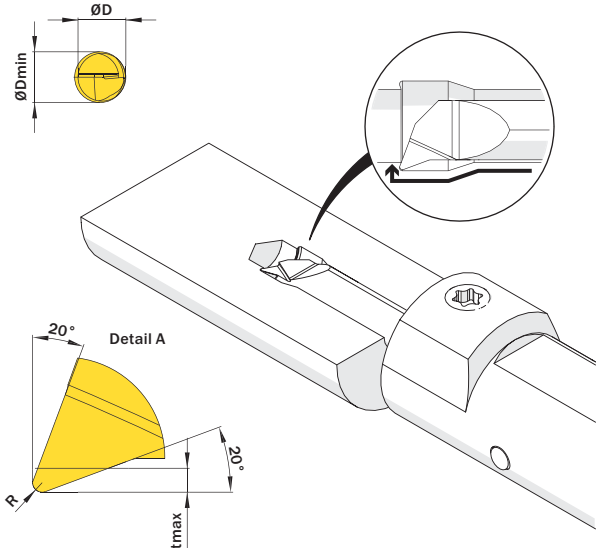


Abbildung zeigt / Drawing shows: A04.2010.06.22.10 Y R



Mehr Informationen zur Kühlmittelzufuhr finden Sie auf Seite 22
Additional information about through coolant supply on page 22

ØD	L2	ØDmin (Min. Bohrung) ØDmin (min. bore)	R	Kühlmittelzufuhr Through coolant supply	Artikelnummer Part number	Webcode www.simtek.com/webcode	Unsere erste Wahl Our first choice	a	d	f	LH	tmax	Connectcode www.simtek.com/code
mm	mm	mm	mm				P K M N S	mm	mm	mm	mm	mm	

Fortgesetzte Tabelle
Continued Table

Verwandte Werkzeuge finden Sie auch auf der vorhergehenden Seite!
Related items can be found on the previous page as well!

▼ ØDmin (Min. Bohrung) // ØDmin (min. bore) = 3,2 mm																			
4,0	10,2	3,2	0,15	-	A04.2015.10.32.15 YR/L	R	AGPV	L	ANEV	X800 X400	2,95	2,55	1,45	13,0	0,2	R	A04.R	L	A04.L
4,0	10,2	3,2	0,15	+	A04.2C15.10.32.15 YR/L	R	AXBP	L	AXBX	X800 X400	2,95	2,55	1,95	13,0	0,2	R	A04C.R	L	A04C.L
4,0	15,2	3,2	0,15	-	A04.2015.15.32.15 YR/L	R	ADP3	L	ACQ5	X800 X400	2,95	2,55	1,45	18,0	0,2	R	A04.R	L	A04.L
4,0	15,2	3,2	0,15	+	A04.2C15.15.32.15 YR/L	R	AXBQ	L	AXBY	CBN	2,95	2,55	1,95	18,0	0,2	R	A04C.R	L	A04C.L
4,0	20,3	3,2	0,15	-	A04.2015.20.32.15 YR/L	R	ADQT	L	AMTZ	X800 X400	2,95	2,55	1,45	23,0	0,2	R	A04.R	L	A04.L
4,0	20,3	3,2	0,15	+	A04.2C15.20.32.15 YR/L	R	AXBS	L	AXBZ	X800 X400	2,95	2,55	1,95	23,0	0,2	R	A04C.R	L	A04C.L
▼ ØDmin (Min. Bohrung) // ØDmin (min. bore) = 4,2 mm																			
4,0	10,2	4,2	0,15	+	A04.2020.10.42.15 YR/L	R	ANM5	L	APP6	X800 X400	3,95	3,45	1,95	13,0	0,3	R	A04C.R	L	A04C.L
4,0	15,2	4,2	0,15	+	A04.2020.15.42.15 YR/L	R	AGMX	L	AM49	X800 X400	3,95	3,45	1,95	18,0	0,3	R	A04C.R	L	A04C.L
4,0	20,3	4,2	0,15	+	A04.2020.20.42.15 YR/L	R	ABF1	L	AM26	X800 X400	3,95	3,45	1,95	23,0	0,3	R	A04C.R	L	A04C.L
4,0	25,4	4,2	0,15	+	A04.2020.25.42.15 YR/L	R	AB94	L	APN2	X800 X400	3,95	3,45	1,95	28,0	0,3	R	A04C.R	L	A04C.L
▼ ØDmin (Min. Bohrung) // ØDmin (min. bore) = 5,2 mm																			
5,0	10,2	5,2	0,2	+	A05.2025.10.52.20 YR/L	R	APTK	L	AK53	X800 X400	4,95	4,2	2,45	13,0	0,5	R	A05.R	L	A05.L
5,0	15,2	5,2	0,2	+	A05.2025.15.52.20 YR/L	R	ANUH	L	AF44	X800 X400	4,95	4,2	2,45	18,0	0,5	R	A05.R	L	A05.L
5,0	20,3	5,2	0,2	+	A05.2025.20.52.20 YR/L	R	AGM9	L	AEE5	X800 X400	4,95	4,2	2,45	23,0	0,5	R	A05.R	L	A05.L
5,0	25,4	5,2	0,2	+	A05.2025.25.52.20 YR/L	R	A2BD	L	A2BJ	X800 X400	4,95	4,2	2,45	28,0	0,5	R	A05.R	L	A05.L
5,0	30,5	5,2	0,2	+	A05.2025.30.52.20 YR/L	R	AB78	L	AGJJ	X800 X400	4,95	4,2	2,45	33,0	0,5	R	A05.R	L	A05.L
▼ ØDmin (Min. Bohrung) // ØDmin (min. bore) = 6,2 mm																			
6,0	40,6	6,2	0,2	+	A06.2030.40.62.20 YR/L	R	AW93	L	AXAY	X800 X400	5,95	5,25	2,95	43,0	0,5	R	A06.R	L	A06.L
▼ ØDmin (Min. Bohrung) // ØDmin (min. bore) = 7,2 mm																			
7,0	50,8	7,2	0,2	+	A07.2035.50.72.20 YR/L	R	AW94	L	AXAZ	X800 X400	6,95	6,25	3,45	53,0	0,5	R	A07.R	L	A07.L

Bestellbeispiel // Order example: A04.2020.25.42.15 YR X800 (R = Rechte Ausführung // Right hand version, X800 = Schneidstoff // Grade)

Kopieren / Profildrehen mit 32°

Geeignet ab Bohrungsdurchmesser 2,2 mm.

Copying / Profiling with 32°

For use in bores as of minimum bore diameter 2,2 mm.

Schnittwerte (Start) // Cutting parameters (start)

f	Vc
0,02 mm/U	Seite/Page 429

Passende Klemmhalter auf Seite // Suitable toolholders on page

26, 27, 28, 31, 32, 33, 34, 35, 36,
 40, 41, 42, 43, 44, 45, 50, 51, 53,
 55, 56, 57, 58, 60, 61, 62, 63, 64,
 65, 66, 67, 68, 69



SP HM R Legende Legend 139
 Scan QR-Code Oder besuchen Sie // Or Visit
www.simtek.info/cp/1335

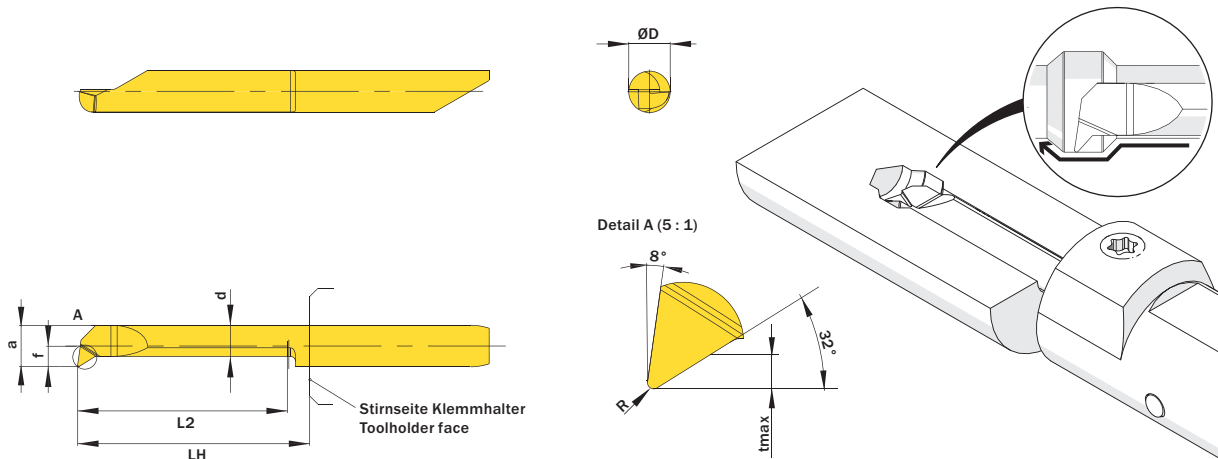


Abbildung zeigt / Drawing shows: A05.3225.25.52.15 Y R

Mehr Informationen zur Kühlmittelzufuhr finden Sie auf Seite 22
 Additional information about through coolant supply on page 22

ØD	f	L2	ØDmin (Min. Bohrung) ØDmin (min. bore)	R	Kühlmittelzufuhr Through coolant supply	Artikelnummer Part number	Webcode www.simtek.com/webcode	Unsere erste Wahl Our first choice	a	d	LH	tmax	Connectcode www.simtek.com/ccode	
mm	mm	mm	mm	mm				P K M N S	mm	mm	mm	mm		
▼ ØDmin (Min. Bohrung) // ØDmin (min. bore) = 2,2 mm														
4,0	0,95	10,2	2,2	0,1	+	A04.3210.10.22.10 YR	A50N	X800 X400	1,95	1,35	13,0	0,4	A04.R A04C.R	new
▼ ØDmin (Min. Bohrung) // ØDmin (min. bore) = 2,7 mm														
4,0	1,2	15,2	2,7	0,1	+	A04.3212.15.27.10 YR	A50Q	X800 X400	2,45	1,75	18,0	0,5	A04.R A04C.R	new
▼ ØDmin (Min. Bohrung) // ØDmin (min. bore) = 3,2 mm														
4,0	1,45	15,2	3,2	0,1	+	A04.3215.15.32.10 YR	A50T	X800 X400	2,95	2,15	18,0	0,6	A04.R A04C.R	new
▼ ØDmin (Min. Bohrung) // ØDmin (min. bore) = 4,2 mm														
4,0	1,95	10,2	4,2	0,15	+	A04.3220.10.42.15 YR	A50V	X800 X400	3,95	2,95	13,0	0,8	A04C.R	new
4,0	1,95	20,3	4,2	0,15	+	A04.3220.20.42.15 YR	A50X	X800 X400	3,95	2,95	23,0	0,8	A04C.R	new
▼ ØDmin (Min. Bohrung) // ØDmin (min. bore) = 5,2 mm														
5,0	2,45	15,2	5,2	0,15	+	A05.3225.15.52.15 YR	A50Z	X800 X400	4,95	3,75	18,0	1,0	A05.R	new
5,0	2,45	25,4	5,2	0,15	+	A05.3225.25.52.15 YR	A501	X800 X400	4,95	3,75	28,0	1,0	A05.R	new
5,0	2,45	35,6	5,2	0,15	+	A05.3225.35.52.15 YR	A509	X800 X400	4,95	3,75	38,0	1,0	A05.R	new
▼ ØDmin (Min. Bohrung) // ØDmin (min. bore) = 6,2 mm														
6,0	2,95	20,3	6,2	0,15	+	A06.3230.20.62.15 YR	A503	X800 X400	5,95	3,95	23,0	1,8	A06.R	new
6,0	2,95	30,5	6,2	0,15	+	A06.3230.30.62.15 YR	A505	X800 X400	5,95	3,95	33,0	1,8	A06.R	new
6,0	2,95	40,6	6,2	0,15	+	A06.3230.40.62.15 YR	A507	X800 X400	5,95	3,95	43,0	1,8	A06.R	new

Bestellbeispiel // Order example: A06.3230.40.62.15 YR X800 (R = Rechte Ausführung // Right hand version, X800 = Schneidstoff // Grade)

Kopieren / Profildrehen mit 47°

Geeignet ab Bohrungsdurchmesser 2,2 mm.

Copying / Profiling with 47°

For use in bores as of minimum bore diameter 2,2 mm.

Schnittwerte (Start) // Cutting parameters (start)

f	Vc
0,02 mm/U	Seite/Page 429

Passende Klemmhalter auf Seite // Suitable toolholders on page

- 26, 27, 28, 29, 31, 32, 33, 34, 35,
- 36, 37, 40, 41, 42, 43, 44, 45, 46,
- 50, 51, 52, 53, 54, 55, 56, 57, 58,
- 60, 61, 62, 63, 64, 65, 66, 67, 68,
- 69



SP **HM** **R** **Legende** **139**
Legend
 Scan QR-Code Oder besuchen Sie // Or Visit
www.simtek.info/cp/753

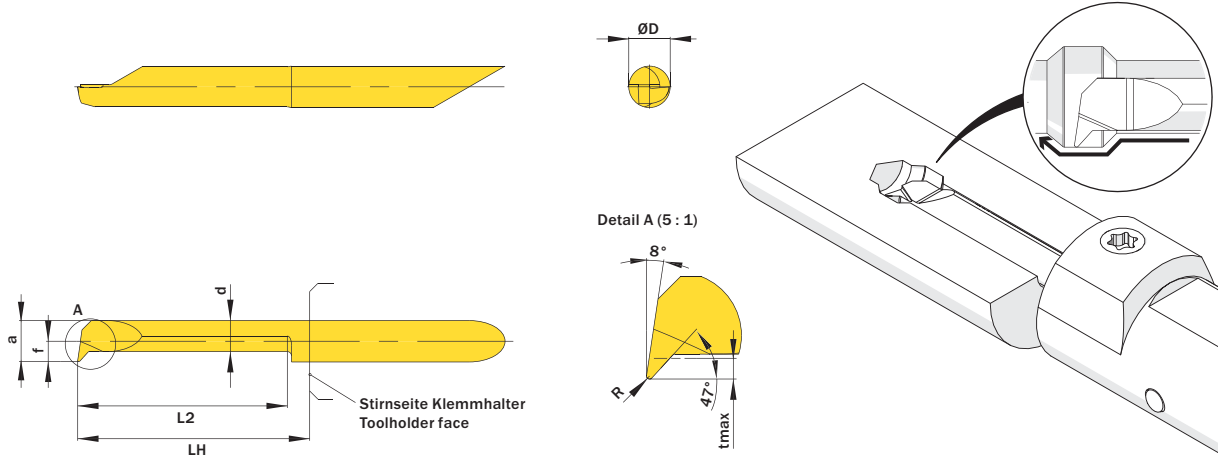


Abbildung zeigt / Drawing shows: A05.4725.25.52.15 Y R



Mehr Informationen zur Kühlmittelzufuhr finden Sie auf Seite 22
 Additional information about through coolant supply on page 22

ØD	f	L2	ØDmin (Min. Bohrung) ØDmin (min. bore)	R	Kühlmittelzufuhr Through coolant supply	Artikelnummer Part number	Webcode www.simtek.com/webcode	Unsere erste Wahl Our first choice	a	d	LH	tmax	Connectcode www.simtek.com/code
mm	mm	mm	mm	mm				P K M N S	mm	mm	mm	mm	
▼ ØDmin (Min. Bohrung) // ØDmin (min. bore) = 2,2 mm													
4,0	0,95	10,2	2,2	0,1	+	A04.4710.10.22.10 YR/L	R AEJJ L ACYG	X800 X400	1,95	1,35	13,0	0,4	R A04.R A04C.R L A04.L A04C.L
▼ ØDmin (Min. Bohrung) // ØDmin (min. bore) = 2,7 mm													
4,0	1,2	15,2	2,7	0,1	+	A04.4712.15.27.10 YR/L	R ANTX L AE5S	X800 X400	2,45	1,75	18,0	0,5	R A04.R A04C.R L A04.L A04C.L
▼ ØDmin (Min. Bohrung) // ØDmin (min. bore) = 3,2 mm													
4,0	1,45	15,2	3,2	0,1	+	A04.4715.15.32.10 YR/L	R ADSB L AHTB	X800 X400	2,95	2,15	18,0	0,6	R A04.R A04C.R L A04.L A04C.L
▼ ØDmin (Min. Bohrung) // ØDmin (min. bore) = 4,2 mm													
4,0	1,95	20,3	4,2	0,15	+	A04.4720.20.42.15 YR/L	R AMFJ L AAEU	X800 X400	3,95	2,95	23,0	0,8	R A04C.R L A04C.L
▼ ØDmin (Min. Bohrung) // ØDmin (min. bore) = 5,2 mm													
5,0	2,45	15,2	5,2	0,15	+	A05.4725.15.52.15 YR/L	R AYD3 L AYD4	X800 X400	4,95	3,75	18,0	1,0	R A05.R L A05.L
5,0	2,45	25,4	5,2	0,15	+	A05.4725.25.52.15 YR/L	R AEMF L ANUD	X800 X400	4,95	3,75	28,0	1,0	R A05.R L A05.L
▼ ØDmin (Min. Bohrung) // ØDmin (min. bore) = 6,2 mm													
6,0	2,95	20,3	6,2	0,15	+	A06.4730.20.62.15 YR/L	R AACY L AKJK	X800 X400	5,95	3,95	23,0	1,8	R A06.R L A06.L
6,0	2,95	30,5	6,2	0,15	+	A06.4730.30.62.15 YR/L	R AJ6F L AE5W	X800 X400	5,95	3,95	33,0	1,8	R A06.R L A06.L
▼ ØDmin (Min. Bohrung) // ØDmin (min. bore) = 7,2 mm													
7,0	3,45	40,6	7,2	0,2	+	A07.4735.40.72.20 YR/L	R AQ9E L AQ9F	X800 X400	6,95	4,15	43,0	2,5	R A07.R L A07.L

Bestellbeispiel // Order example: A05.4725.15.52.15 YR X800 (R = Rechte Ausführung // Right hand version, X800 = Schneidstoff // Grade)

simturn AX
simturn DX
simturn PX
simturn H2
simturn K2
simturn C4
simturn GX
simturn E3
simturn E12
simturn FX
simturn Decolletage
simturn OA
Index

Bohrungen drehen

Geeignet ab Bohrungsdurchmesser 3,2 mm.

Boring

For use in bores as of minimum bore diameter 3,2 mm.

Schnittwerte (Start) // Cutting parameters (start)

f	Vc
0,02 mm/U	Seite/Page 429

Passende Klemmhalter auf Seite // Suitable toolholders on page

26, 27, 31, 32, 33, 34, 35, 40, 41,
 43, 44, 50, 51, 53, 55, 56, 57, 60,
 61, 62, 63, 65, 66, 67, 68, 69



SP
HM
R

Legende
 Legend **139**

Scan QR-Code Oder besuchen Sie // Or Visit
www.simtek.info/cp/754

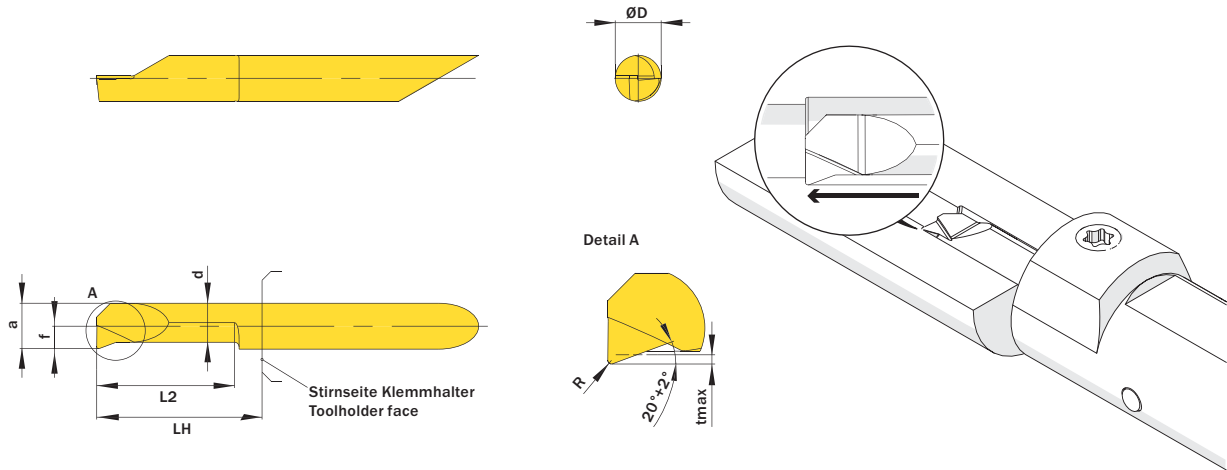
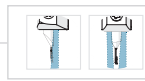


Abbildung zeigt / Drawing shows: A05.9025.15.52.20 Y R



Mehr Informationen zur Kühlmittelzufuhr finden Sie auf Seite 22
 Additional information about through coolant supply on page 22

ØD	L2	ØDmin (Min. Bohrung) ØDmin (min. bore)	R	Kühlmittelzufuhr Through coolant supply	Artikelnummer Part number	Webcode www.simtek.com/webcode	Unsere erste Wahl Our first choice	a	d	f	LH	tmax	Connectcode www.simtek.com/code
mm	mm	mm	mm				P K M N S	mm	mm	mm	mm	mm	
▼ ØDmin (Min. Bohrung) // ØDmin (min. bore) = 3,2 mm													
4,0	12,2	3,2	0,15	+	A04.9015.12.32.15 YR/L	R APB9 L ADVC	X800 X400	2,95	2,55	1,45	15,0	0,2	R A04.R L A04.L
▼ ØDmin (Min. Bohrung) // ØDmin (min. bore) = 4,2 mm													
4,0	15,2	4,2	0,15	+	A04.9020.15.42.15 YR/L	R APXB L ANKP	X800 X400	3,95	3,45	1,95	18,0	0,3	R A04C.R L A04C.L
▼ ØDmin (Min. Bohrung) // ØDmin (min. bore) = 5,2 mm													
5,0	10,2	5,2	0,2	+	A05.9025.10.52.20 YR/L	R AJ84 L AHEC	X800 X400	4,95	4,2	2,45	13,0	0,5	R A05.R L A05.L
5,0	15,2	5,2	0,2	+	A05.9025.15.52.20 YR/L	R AHSM L AKCD	X800 X400	4,95	4,2	2,45	18,0	0,5	R A05.R L A05.L
5,0	20,3	5,2	0,2	+	A05.9025.20.52.20 YR/L	R AM84 L AJ5E	X800 X400	4,95	4,2	2,45	23,0	0,5	R A05.R L A05.L

Bestellbeispiel // Order example: **A04.9015.12.32.15 YR X800** (R = Rechte Ausführung // Right hand version, X800 = Schneidstoff // Grade)

Ausdrehen und Fasen

Geeignet ab Bohrungsdurchmesser 5,2 mm.

Boring and Chamfering

For use in bores as of minimum bore diameter 5,2 mm.

Schnittwerte (Start) // Cutting parameters (start)

f	Vc
0,02 mm/U	Seite/Page 429

Passende Klemmhalter auf Seite // Suitable toolholders on page

27, 28, 29, 31, 33, 35, 36, 37, 41,
42, 44, 45, 46, 50, 51, 52, 53, 54,
55, 56, 57, 58, 61, 62, 63, 64, 65,
66, 67, 68, 69

SP

HM

R

Legende
Legend

139

Scan
QR-Code

Oder besuchen Sie // Or Visit
www.simtek.info/cp/756

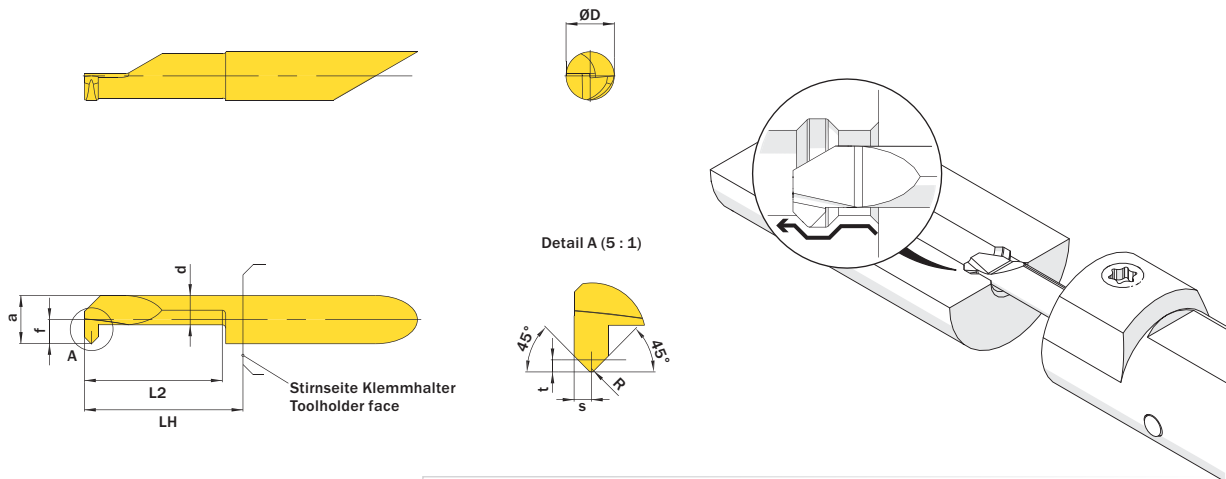


Abbildung zeigt / Drawing shows: A07.4545.20.72 F R

Mehr Informationen zur Kühlmittelzufuhr finden Sie auf Seite 22
Additional information about through coolant supply on page 22

ØD	L2	ØDmin (Min. Bohrung) ØDmin (min. bore)	Kühlmittelzufuhr Through coolant supply	Artikelnummer Part number	Webcode www.simtek.com/webcode	Unsere erste Wahl Our first choice	a	d	f	LH	R	S	t	Connectcode www.simtek.com/ccode
mm	mm	mm				P K M N S	mm	mm	mm	mm	mm	mm	mm	
▼ ØDmin (Min. Bohrung) // ØDmin (min. bore) = 5,2 mm														
5,0	15,4	5,2	+	A05.4545.15.52 FR/L	R ANEE L AB3U	X800 X400	4,95	3,75	2,45	18,0	0,2	1,0	0,7	R A05.R L A05.L
5,0	20,3	5,2	+	A05.4545.20.52 FR/L	R AAYP L ANDH	X800 X400	4,95	3,75	2,45	23,0	0,2	1,0	0,7	R A05.R L A05.L
▼ ØDmin (Min. Bohrung) // ØDmin (min. bore) = 6,2 mm														
6,0	20,3	6,2	+	A06.4545.20.62 FR/L	R AG75 L ANKN	X800 X400	5,95	3,95	2,95	23,0	0,2	1,0	0,7	R A06.R L A06.L
6,0	25,4	6,2	+	A06.4545.25.62 FR/L	R AJ5J L ACW6	X800 X400	5,95	3,95	2,95	28,0	0,2	1,0	0,7	R A06.R L A06.L
▼ ØDmin (Min. Bohrung) // ØDmin (min. bore) = 7,2 mm														
7,0	20,3	7,2	+	A07.4545.20.72 FR/L	R AJC3 L AC4S	X800 X400	6,95	4,25	3,45	23,0	0,2	1,0	0,7	R A07.R L A07.L
7,0	40,6	7,2	+	A07.4545.40.72 FR/L	R AHP6 L AHCW	X800 X400	6,95	4,25	3,45	43,0	0,2	1,0	0,7	R A07.R L A07.L

Bestellbeispiel // Order example: **A05.4545.15.52 FR X800** (R = Rechte Ausführung // Right hand version, X800 = Schneidstoff // Grade)

simturn AX
simturn DX
simturn PX
simturn H2
simturn K2
simturn C4
simturn GX
simturn E3
simturn E12
simturn FX
simturn Decolletage
simturn OA
Index

Fasen

Bspw. für das nachträgliche Anfasen von Tieflochbohrungen.
Geeignet ab Bohrungsdurchmesser 1,0 mm.

Chamfering

Post chamfering of deep-hole bores.
For use in bores as of minimum bore diameter 1,0 mm.

Schnittwerte (Start) // Cutting parameters (start)

f	Vc
0,02 mm/U	Seite/Page 429

Passende Klemmhalter auf Seite // Suitable toolholders on page

28, 31, 36, 42, 45, 50, 51, 53, 55, 56, 58, 61, 62, 64, 65, 66, 67, 68, 69



Legende
Legend **139**

Scan
QR-Code

Oder besuchen Sie // Or Visit
www.simtek.info/cp/758

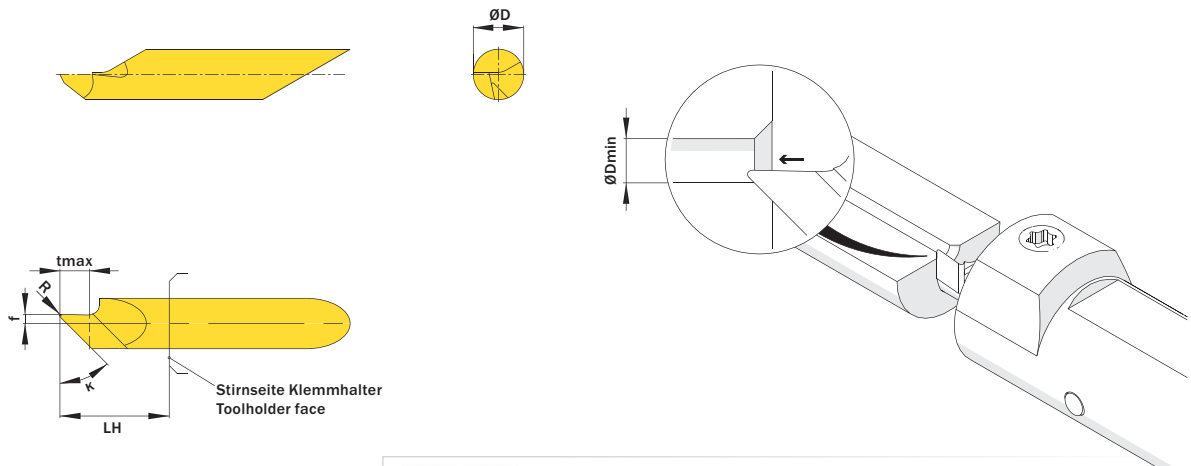


Abbildung zeigt / Drawing shows: A06.0045.11.20 AF R

Mehr Informationen zur Kühlmittelzufuhr finden Sie auf Seite 22
Additional information about through coolant supply on page 22

ØD	κ	f	R	Kühlmittelzufuhr Through coolant supply	Artikelnummer Part number	Webcode www.simtek.com/webcode	Unsere erste Wahl Our first choice	ØDmin (Min. Bohrung) ØDmin (min. bore)	LH	tmax	Connectcode www.simtek.com/code
mm		mm	mm				P K M N S	mm	mm	mm	
▼ κ = 30°											
6,0	30°	1,7	0,2	+	A06.0030.17.20 AF R/L	R A5ST L A5SV	X800 X400	1,0	13,0	2,2	R A06.R L A06.L new
▼ κ = 45°											
6,0	45°	1,1	0,2	+	A06.0045.11.20 AF R/L	R AJ6Q L ACUY	X800 X400	1,0	13,0	3,5	R A06.R L A06.L
▼ κ = 60°											
6,0	60°	0,5	0,2	+	A06.0060.05.20 AF R/L	R ABJY L ACF6	X800 X400	1,0	13,0	4,0	R A06.R L A06.L

Bestellbeispiel // Order example: **A06.0045.11.20 AF R X800** (R = Rechte Ausführung // Right hand version, X800 = Schneidstoff // Grade)

Rückwärtsdrehen

Geeignet ab Bohrungsdurchmesser 3,2 mm.

Back Boring

For use in bores as of minimum bore diameter 3,2 mm.

Schnittwerte (Start) // Cutting parameters (start)

f	Vc
0,02 mm/U	Seite/Page 429

Passende Klemmhalter auf Seite // Suitable toolholders on page

26, 27, 28, 29, 31, 32, 33, 34, 35,
36, 37, 40, 41, 42, 43, 44, 45, 46,
50, 51, 52, 53, 54, 55, 56, 57, 58,
60, 61, 62, 63, 64, 65, 66, 67, 68,
69

SP
HM
R

Legende
Legend **139**

Scan
QR-Code

Oder besuchen Sie // Or Visit
www.simtek.info/cp/776

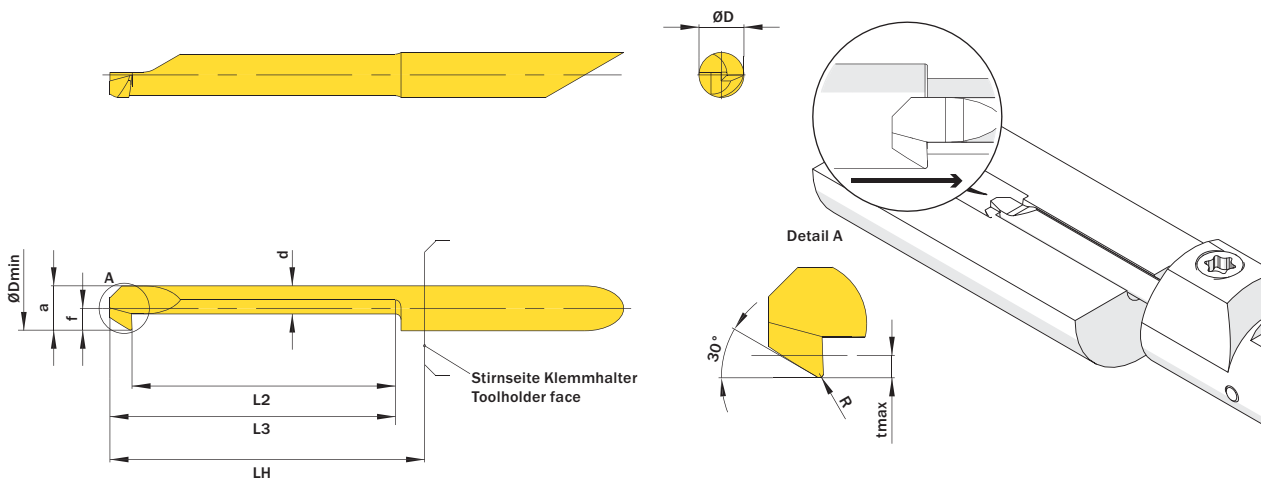


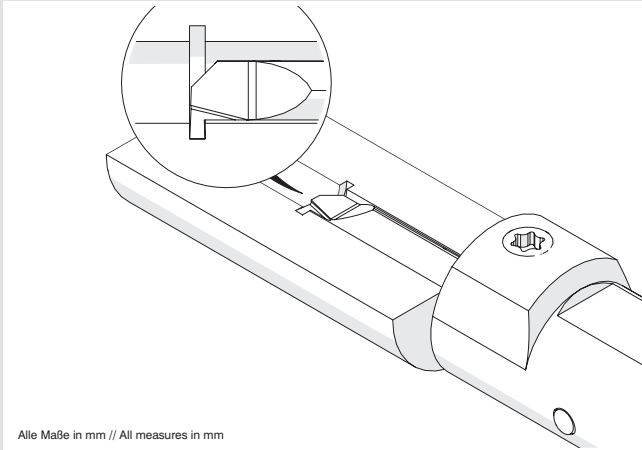
Abbildung zeigt / Drawing shows: A04.3020.25.42.15 Y R

Mehr Informationen zur Kühlmittelzufuhr finden Sie auf Seite 22
Additional information about through coolant supply on page 22

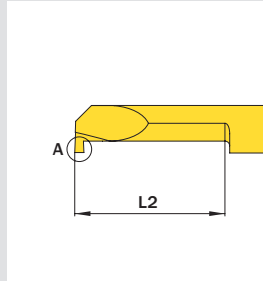
ØD	ØDmin (Min. Bohrung) ØDmin (min. bore)	R	Kühlmittelzufuhr Through coolant supply	Artikelnummer Part number	Webcode www.simtek.com/webcode	Unsere erste Wahl Our first choice	a	d	f	LH	L2	L3 (Max. Bohrungstiefe) L3 (max. depth of bore)	tmax	Connectcode www.simtek.com/code
mm	mm	mm				P K M N S	mm	mm	mm	mm	mm	mm	mm	
▼ ØDmin (Min. Bohrung) // ØDmin (min. bore) = 3,2 mm														
4,0	3,2	0,1	+	A04.3015.15.32.10 YR/L	R AASA L AH7W	X800 X400	2,95	2,3	1,45	18,0	13,2	15,2	0,5	R A04.R A04C.R L A04.L A04C.L
4,0	3,2	0,1	+	A04.3015.20.32.10 YR/L	R AJHJ L AM80	X800 X400	2,95	2,3	1,45	23,0	18,3	20,3	0,5	R A04.R A04C.R L A04.L A04C.L
▼ ØDmin (Min. Bohrung) // ØDmin (min. bore) = 4,2 mm														
4,0	4,2	0,15	+	A04.3020.15.42.15 YR/L	R AC41 L AJBG	X800 X400	3,95	2,95	1,95	18,0	13,2	15,2	0,8	R A04C.R L A04C.L
4,0	4,2	0,15	+	A04.3020.25.42.15 YR/L	R AABT L AEHK	X800 X400	3,95	2,95	1,95	28,0	23,4	25,4	0,8	R A04C.R L A04C.L
▼ ØDmin (Min. Bohrung) // ØDmin (min. bore) = 5,2 mm														
5,0	5,2	0,2	+	A05.3025.20.52.20 YR/L	R ACNQ L AJKY	X800 X400	4,95	3,7	2,45	23,0	18,3	20,3	1,0	R A05.R L A05.L
5,0	5,2	0,2	+	A05.3025.30.52.20 YR/L	R AMAF L AD06	X800 X400	4,95	3,7	2,45	33,0	28,5	30,5	1,0	R A05.R L A05.L
▼ ØDmin (Min. Bohrung) // ØDmin (min. bore) = 6,2 mm														
6,0	6,2	0,2	+	A06.3030.20.62.20 YR/L	R AH02 L AJGE	X800 X400	5,95	3,85	2,95	23,0	18,3	20,3	1,8	R A06.R L A06.L
6,0	6,2	0,2	+	A06.3030.30.62.20 YR/L	R ABGK L AEXA	X800 X400	5,95	3,85	2,95	33,0	28,5	30,5	1,8	R A06.R L A06.L
▼ ØDmin (Min. Bohrung) // ØDmin (min. bore) = 7,2 mm														
7,0	7,2	0,2	+	A07.3035.20.72.20 YR/L	R AM7G L ABY0	X800 X400	6,95	4,1	3,45	23,0	17,3	20,3	2,5	R A07.R L A07.L
7,0	7,2	0,2	+	A07.3035.30.72.20 YR/L	R APVP L AA5G	X800 X400	6,95	4,1	3,45	33,0	27,5	30,5	2,5	R A07.R L A07.L

Bestellbeispiel // Order example: **A07.3035.20.72.20 YR X800** (R = Rechte Ausführung // Right hand version, X800 = Schneidstoff // Grade)

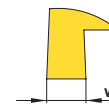
Standardwerkzeuge // Standard Tools

Nutenstechen
Grooving

Alle Maße in mm // All measures in mm



Detail A



Artikelnummer Part number	ØDmin (Min. Bohrung) ØDmin (min. bore)	w	L2	siehe Seite see Page
A04.0050.06.20 GR/L	2,0	0,5	6,1	103
A04.0050.06.20 GR/L	2,0	0,5	6,1	103
A04.0050.09.20 GR/L	2,0	0,5	9,1	103
A04.0050.09.20 GR/L	2,0	0,5	9,1	103
A04.0050.12.20 GR/L	2,0	0,5	12,2	103
A04.0050.12.20 GR/L	2,0	0,5	12,2	103
A04.0070.08.30 GR/L	3,0	0,7	8,1	103
A04.0070.08.30 GR/L	3,0	0,7	8,1	103
A04.0070.12.30 GR/L	3,0	0,7	12,2	103
A04.0070.12.30 GR/L	3,0	0,7	12,2	103
A04.0070.16.30 GR/L	3,0	0,7	16,3	103
A04.0070.16.30 GR/L	3,0	0,7	16,3	103
A04.0078.10.42 GR/L	4,2	0,787	10,2	103
A04.0078.15.42 GR/L	4,2	0,787	15,2	103
A04.0078.20.42 GR/L	4,2	0,787	20,3	103
A04.0078.25.42 GR/L	4,2	0,787	25,4	103
A04.0100.10.42 GR/L	4,2	1,0	10,2	103
A04.0100.15.42 GR/L	4,2	1,0	15,2	103
A04.0100.20.42 GR/L	4,2	1,0	20,3	103
A05.0078.10.52 GR/L	5,2	0,787	10,2	104
A05.0078.15.52 GR/L	5,2	0,787	15,2	104
A05.0078.20.52 GR/L	5,2	0,787	20,3	104
A05.0078.25.52 GR/L	5,2	0,787	25,4	104
A05.0078.30.52 GR/L	5,2	0,787	30,5	104
A05.0078.35.52 GR/L	5,2	0,787	35,6	104
A05.0100.10.52 GR/L	5,2	1,0	10,2	104
A05.0100.15.52 GR/L	5,2	1,0	15,2	104
A05.0100.20.52 GR/L	5,2	1,0	20,3	104
A05.0100.25.52 GR/L	5,2	1,0	25,4	104
A05.0100.30.52 GR/L	5,2	1,0	30,5	104
A05.0100.35.52 GR/L	5,2	1,0	35,6	104
A05.0117.10.52 GR/L	5,2	1,168	10,2	104
A05.0117.15.52 GR/L	5,2	1,168	15,2	104
A05.0117.20.52 GR/L	5,2	1,168	20,3	104
A05.0117.25.52 GR/L	5,2	1,168	25,4	104
A05.0117.30.52 GR/L	5,2	1,168	30,5	104
A05.0117.35.52 GR/L	5,2	1,168	35,6	104
A05.0150.10.52 GR/L	5,2	1,5	10,2	105
A05.0150.15.52 GR/L	5,2	1,5	15,2	105
A05.0150.20.52 GR/L	5,2	1,5	20,3	105
A05.0150.25.52 GR/L	5,2	1,5	25,4	105
A05.0150.30.52 GR/L	5,2	1,5	30,5	105
A05.0150.35.52 GR/L	5,2	1,5	35,6	105
A05.0157.10.52 GR/L	5,2	1,575	10,2	105
A05.0157.15.52 GR/L	5,2	1,575	15,2	105
A05.0157.20.52 GR/L	5,2	1,575	20,3	105
A05.0157.25.52 GR/L	5,2	1,575	25,4	105
A05.0157.30.52 GR/L	5,2	1,575	30,5	105
A05.0198.10.52 GR/L	5,2	1,981	10,2	105
A05.0198.15.52 GR/L	5,2	1,981	15,2	105
A05.0198.20.52 GR/L	5,2	1,981	20,3	105
A05.0198.25.52 GR/L	5,2	1,981	25,4	105
A05.0198.30.52 GR/L	5,2	1,981	30,5	105
A05.0198.35.52 GR/L	5,2	1,981	35,6	105
A05.0200.10.52 GR/L	5,2	2,0	10,2	106
A05.0200.15.52 GR/L	5,2	2,0	15,2	106
A05.0200.20.52 GR/L	5,2	2,0	20,3	106
A05.0200.25.52 GR/L	5,2	2,0	25,4	106
A05.0200.30.52 GR/L	5,2	2,0	30,5	106
A06.0078.10.62 GR/L	6,2	0,787	10,2	106
A06.0078.15.62 GR/L	6,2	0,787	15,2	106
A06.0078.20.62 GR/L	6,2	0,787	20,3	106
A06.0078.25.62 GR/L	6,2	0,787	25,4	106
A06.0078.30.62 GR/L	6,2	0,787	30,5	106
A06.0078.35.62 GR/L	6,2	0,787	35,6	106
A06.0100.30.62 GR/L	6,2	1,0	30,5	106
A06.0150.10.72 GR/L	7,2	1,5	10,2	111
A06.0150.15.72 GR/L	7,2	1,5	15,2	111
A06.0150.20.72 GR/L	7,2	1,5	20,3	111
A06.0150.25.72 GR/L	7,2	1,5	25,4	111
A06.0150.30.72 GR/L	7,2	1,5	30,5	111
A06.0150.35.72 GR/L	7,2	1,5	35,6	111
A06.0157.10.72 GR/L	7,2	1,575	10,2	111
A06.0157.15.72 GR/L	7,2	1,575	15,2	111
A06.0157.20.72 GR/L	7,2	1,575	20,3	111
A06.0157.25.72 GR/L	7,2	1,575	25,4	111
A06.0157.30.72 GR/L	7,2	1,575	30,5	111
A06.0157.35.72 GR/L	7,2	1,575	35,6	111
A06.0157.40.72 GR/L	7,2	1,575	40,6	111
A06.0198.10.72 GR/L	7,2	1,981	10,2	111
A06.0198.15.72 GR/L	7,2	1,981	15,2	111
A06.0198.20.72 GR/L	7,2	1,981	20,3	111
A06.0198.25.72 GR/L	7,2	1,981	25,4	111
A06.0198.30.72 GR/L	7,2	1,981	30,5	111
A06.0198.35.72 GR/L	7,2	1,981	35,6	111
A06.0198.40.72 GR/L	7,2	1,981	40,6	111
A06.0200.10.62 GR/L	6,2	2,0	10,2	109
A06.0200.15.62 GR/L	6,2	2,0	15,2	109
A06.0200.20.62 GR/L	6,2	2,0	20,3	109
A06.0200.25.62 GR/L	6,2	2,0	25,4	109
A06.0200.30.62 GR/L	6,2	2,0	30,5	109
A07.0078.10.72 GR/L	7,2	0,787	10,2	109
A07.0078.15.72 GR/L	7,2	0,787	15,2	109
A07.0078.20.72 GR/L	7,2	0,787	20,3	109
A07.0078.25.72 GR/L	7,2	0,787	25,4	109
A07.0078.30.72 GR/L	7,2	0,787	30,5	109
A07.0078.35.72 GR/L	7,2	0,787	35,6	109
A07.0078.40.72 GR/L	7,2	0,787	40,6	109
A07.0100.10.72 GR/L	7,2	1,0	10,2	110
A07.0100.15.72 GR/L	7,2	1,0	15,2	110
A07.0100.20.72 GR/L	7,2	1,0	20,3	110
A07.0100.25.72 GR/L	7,2	1,0	25,4	110
A07.0100.30.72 GR/L	7,2	1,0	30,5	110
A07.0100.35.72 GR/L	7,2	1,0	35,6	110
A07.0100.40.72 GR/L	7,2	1,0	40,6	110
A07.0117.10.72 GR/L	7,2	1,168	10,2	110
A07.0117.15.72 GR/L	7,2	1,168	15,2	110
A07.0117.20.72 GR/L	7,2	1,168	20,3	110
A07.0117.25.72 GR/L	7,2	1,168	25,4	110
A07.0117.30.72 GR/L	7,2	1,168	30,5	110
A07.0117.35.72 GR/L	7,2	1,168	35,6	110
A07.0117.40.72 GR/L	7,2	1,168	40,6	110
A07.0150.10.72 GR/L	7,2	1,5	10,2	111
A07.0150.15.72 GR/L	7,2	1,5	15,2	111
A07.0150.20.72 GR/L	7,2	1,5	20,3	111
A07.0150.25.72 GR/L	7,2	1,5	25,4	111
A07.0150.30.72 GR/L	7,2	1,5	30,5	111
A07.0150.35.72 GR/L	7,2	1,5	35,6	111
A07.0150.40.72 GR/L	7,2	1,5	40,6	111
A07.0157.10.72 GR/L	7,2	1,575	10,2	111
A07.0157.15.72 GR/L	7,2	1,575	15,2	111
A07.0157.20.72 GR/L	7,2	1,575	20,3	111
A07.0157.25.72 GR/L	7,2	1,575	25,4	111
A07.0157.30.72 GR/L	7,2	1,575	30,5	111
A07.0157.35.72 GR/L	7,2	1,575	35,6	111
A07.0157.40.72 GR/L	7,2	1,575	40,6	111

Artikelnummer Part number	ØDmin (Min. Bohrung) ØDmin (min. bore)	w	L2	siehe Seite see Page
A06.0117.15.62 GR/L	6,2	1,168	15,2	107
A06.0117.20.62 GR/L	6,2	1,168	20,3	107
A06.0117.25.62 GR/L	6,2	1,168	25,4	107
A06.0117.30.62 GR/L	6,2	1,168	30,5	107
A06.0117.35.62 GR/L	6,2	1,168	35,6	107
A06.0117.40.62 GR/L	6,2	1,168	40,6	107
A06.0150.10.62 GR/L	6,2	1,5	10,2	108
A06.0150.15.62 GR/L	6,2	1,5	15,2	108
A06.0150.20.62 GR/L	6,2	1,5	20,3	108
A06.0150.25.62 GR/L	6,2	1,5	25,4	108
A06.0150.30.62 GR/L	6,2	1,5	30,5	108
A06.0150.35.62 GR/L	6,2	1,5	35,6	108
A06.0157.10.62 GR/L	6,2	1,575	10,2	108
A06.0157.15.62 GR/L	6,2	1,575	15,2	108
A06.0157.20.62 GR/L	6,2	1,575	20,3	108
A06.0157.25.62 GR/L	6,2	1,575	25,4	108
A06.0157.30.62 GR/L	6,2	1,575	30,5	108
A06.0157.35.62 GR/L	6,2	1,575	35,6	108
A06.0157.40.62 GR/L	6,2	1,575	40,6	108
A06.0198.10.62 GR/L	6,2	1,981	10,2	109
A06.0198.15.62 GR/L	6,2	1,981	15,2	109
A06.0198.20.62 GR/L	6,2	1,981	20,3	109
A06.0198.25.62 GR/L	6,2	1,981	25,4	109
A06.0198.30.62 GR/L	6,2	1,981	30,5	109
A06.0198.35.62 GR/L	6,2	1,981	35,6	109
A06.0198.40.62 GR/L	6,2	1,981	40,6	109
A06.0200.10.62 GR/L	6,2	2,0	10,2	109
A06.0200.15.62 GR/L	6,2	2,0	15,2	109
A06.0200.20.62 GR/L	6,2	2,0	20,3	109
A06.0200.25.62 GR/L	6,2	2,0	25,4	109
A06.0200.30.62 GR/L	6,2	2,0	30,5	109
A07.0078.10.72 GR/L	7,2	0,787	10,2	109
A07.0078.15.72 GR/L	7,2	0,787	15,2	109
A07.0078.20.72 GR/L	7,2	0,787	20,3	109
A07.0078.25.72 GR/L	7,2	0,787	25,4	109
A07.0078.30.72 GR/L	7,2	0,787	30,5	109
A07.0078.35.72 GR/L	7,2	0,787	35,6	109
A07.0078.40.72 GR/L	7,2	0,787	40,6	109
A07.0100.10.72 GR/L	7,2	1,0	10,2	110
A07.0100.15.72 GR/L	7,2	1,0	15,2	110
A07.0100.20.72 GR/L	7,2	1,0	20,3	110
A07.0100.25.72 GR/L	7,2	1,0	25,4	110
A07.0100.30.72 GR/L	7,2	1,0	30,5	110
A07.0100.35.72 GR/L	7,2	1,0	35,6	110
A07.0100.40.72 GR/L	7,2	1,0	40,6	110
A07.0117.10.72 GR/L	7,2	1,168	10,2	110
A07.0117.15.72 GR/L	7,2	1,168	15,2	110
A07.0117.20.72 GR/L	7,2	1,168	20,3	110
A07.0117.25.72 GR/L	7,2	1,168	25,4	110
A07.0117.30.72 GR/L	7,2	1,168	30,5	110
A07.0117.35.72 GR/L	7,2	1,168	35,6	110
A07.0117.40.72 GR/L	7,2	1,168	40,6	110
A07.0150.10.72 GR/L	7,2	1,5	10,2	111
A07.0150.15.72 GR/L	7,2	1,5	15,2	111
A07.0150.20.72 GR/L	7,2	1,5	20,3	111
A07.0150.25.72 GR/L	7,2	1,5	25,4	111
A07.0150.30.72 GR/L	7,2	1,5	30,5	111
A07.0150.35.72 GR/L	7,2	1,5	35,6	111
A07.0150.40.72 GR/L	7,2	1,5	40,6	111
A07.0157.10.72 GR/L	7,2	1,575	10,2	111
A07.0157.15.72 GR/L	7,2	1,575	15,2	111
A07.0157.20.72 GR/L	7,2	1,575	20,3	111
A07.0157.25.72 GR/L	7,2	1,575	25,4	111
A07.0157.30.72 GR/L	7,2	1,575	30,5	111
A07.0157.35.72 GR/L	7,2	1,575	35,6	111
A07.0157.40.72 GR/L	7,2	1,575	40,6	111

Artikelnummer Part number	Ø
------------------------------	---

Nutenstechen

Geeignet ab Bohrungsdurchmesser 2,0 mm.

Grooving

For use in bores as of minimum bore diameter 2,0 mm.

Schnittwerte (Start) // Cutting parameters (start)

f	Vc
0,02 mm/U	Seite/Page 429

Passende Klemmhalter auf Seite // Suitable toolholders on page

26, 31, 32, 33, 34, 40, 41, 43, 50,
51, 53, 55, 56, 57, 60, 62, 63, 65,
66, 67, 68, 69

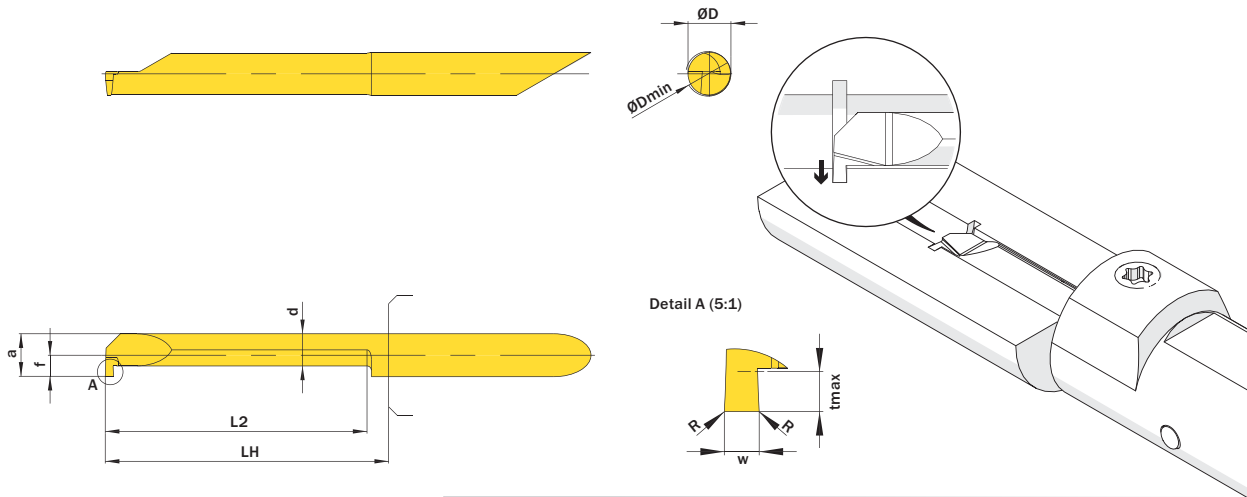
Vergleichbare Werkzeuge auf Seite // Similar tools on page

102



Legende
Legend 139

Scan QR-Code Oder besuchen Sie // Or Visit
www.simtek.info/cp/777



Mehr Informationen zur Kühlmittelzufuhr finden Sie auf Seite 22
Additional information about through coolant supply on page 22

ØD	w ^{+0,03}	L2	ØDmin (Min. Bohrung) ØDmin (min. bore)	Kühlmittelzufuhr Through coolant supply	Artikelnummer Part number	Webcode www.simtek.com/webcode	Unsere erste Wahl Our first choice	a	d	f	LH	R	tmax	Connectcode www.simtek.com/code
mm	mm	mm	mm				P K M N S	mm	mm	mm	mm	mm	mm	
▼ ØDmin (Min. Bohrung) // ØDmin (min. bore) = 2,0 mm														
4,0	0,5	6,1	2,0	●	A04.0050.06.20 GR/L	R AFUW L AM47	X800 X400	1,75	1,15	0,85	13,0	-	0,4	R A04.R L A04.L
4,0	0,5	6,1	2,0	+	A04.C050.06.20 GR/L	R ABQ4 L AN4H	X800 X400	1,75	1,15	1,95	13,0	-	0,4	R A04C.R L A04C.L
4,0	0,5	9,1	2,0	●	A04.0050.09.20 GR/L	R ACJY L AMSE	X800 X400	1,75	1,15	0,85	13,0	-	0,4	R A04.R L A04.L
4,0	0,5	9,1	2,0	+	A04.C050.09.20 GR/L	R AG6V L AGUA	X800 X400	1,75	1,15	1,95	13,0	-	0,4	R A04C.R L A04C.L
4,0	0,5	12,2	2,0	●	A04.0050.12.20 GR/L	R AKDC L AF5Z	X800 X400	1,75	1,15	0,85	18,0	-	0,4	R A04.R L A04.L
4,0	0,5	12,2	2,0	+	A04.C050.12.20 GR/L	R AJZ3 L ACVU	X800 X400	1,75	1,15	1,95	18,0	-	0,4	R A04C.R L A04C.L
▼ ØDmin (Min. Bohrung) // ØDmin (min. bore) = 3,0 mm														
4,0	0,7	8,1	3,0	●	A04.0070.08.30 GR/L	R APXM L AD4E	X800 X400	2,75	1,95	1,35	13,0	-	0,6	R A04.R L A04.L
4,0	0,7	8,1	3,0	+	A04.C070.08.30 GR/L	R AM07 L AMXM	X800 X400	2,75	1,95	1,95	13,0	-	0,6	R A04C.R L A04C.L
4,0	0,7	12,2	3,0	●	A04.0070.12.30 GR/L	R ACVH L ANXB	X800 X400	2,75	1,95	1,35	18,0	-	0,6	R A04.R L A04.L
4,0	0,7	12,2	3,0	+	A04.C070.12.30 GR/L	R ACKP L ANQE	X800 X400	2,75	1,95	1,95	18,0	-	0,6	R A04C.R L A04C.L
4,0	0,7	16,3	3,0	●	A04.0070.16.30 GR/L	R ADVD L AEHK	X800 X400	2,75	1,95	1,35	23,0	-	0,6	R A04.R L A04.L
4,0	0,7	16,3	3,0	+	A04.C070.16.30 GR/L	R AB70 L ANVK	X800 X400	2,75	1,95	1,95	23,0	-	0,6	R A04C.R L A04C.L
▼ ØDmin (Min. Bohrung) // ØDmin (min. bore) = 4,2 mm														
4,0	0,787	10,2	4,2	+	A04.0078.10.42 GR/L	R AFQB L AHW7	X800 X400	3,95	2,95	1,95	13,0	-	0,8	R A04C.R L A04C.L
4,0	0,787	15,2	4,2	+	A04.0078.15.42 GR/L	R AJGY L AFP6	X800 X400	3,95	2,95	1,95	18,0	-	0,8	R A04C.R L A04C.L
4,0	0,787	20,3	4,2	+	A04.0078.20.42 GR/L	R AKJA L ADSG	X800 X400	3,95	2,95	1,95	23,0	-	0,8	R A04C.R L A04C.L
4,0	0,787	25,4	4,2	+	A04.0078.25.42 GR/L	R APCB L AMMY	X800 X400	3,95	2,95	1,95	28,0	-	0,8	R A04C.R L A04C.L
4,0	1,0	10,2	4,2	+	A04.0100.10.42 GR/L	R ANMY L AACT	X800 X400	3,95	2,95	1,95	13,0	-	0,8	R A04C.R L A04C.L
4,0	1,0	15,2	4,2	+	A04.0100.15.42 GR/L	R AAQT L AGWU	X800 X400	3,95	2,95	1,95	18,0	-	0,8	R A04C.R L A04C.L
4,0	1,0	20,3	4,2	+	A04.0100.20.42 GR/L	R ABMQ L AF0K	X800 X400	3,95	2,95	1,95	23,0	-	0,8	R A04C.R L A04C.L

Verwandte Werkzeuge finden Sie auch auf der folgenden Seite!
Related Items can be found on the following page as well!

Fortgesetzte Tabelle
Continued Table

Bestellbeispiel // Order example: A04.0100.10.42 GR X800 (R = Rechte Ausführung // Right hand version, X800 = Schneidstoff // Grade)

Nutenstechen

Geeignet ab Bohrungsdurchmesser 5,2 mm.

Grooving

For use in bores as of minimum bore diameter 5,2 mm.

Schnittwerte (Start) // Cutting parameters (start)

f	Vc
0,02 mm/U	Seite/Page 429

Passende Klemmhalter auf Seite // Suitable toolholders on page

27, 31, 33, 35, 41, 44, 50, 51, 53, 55, 56, 57, 61, 62, 63, 65, 66, 67, 68, 69

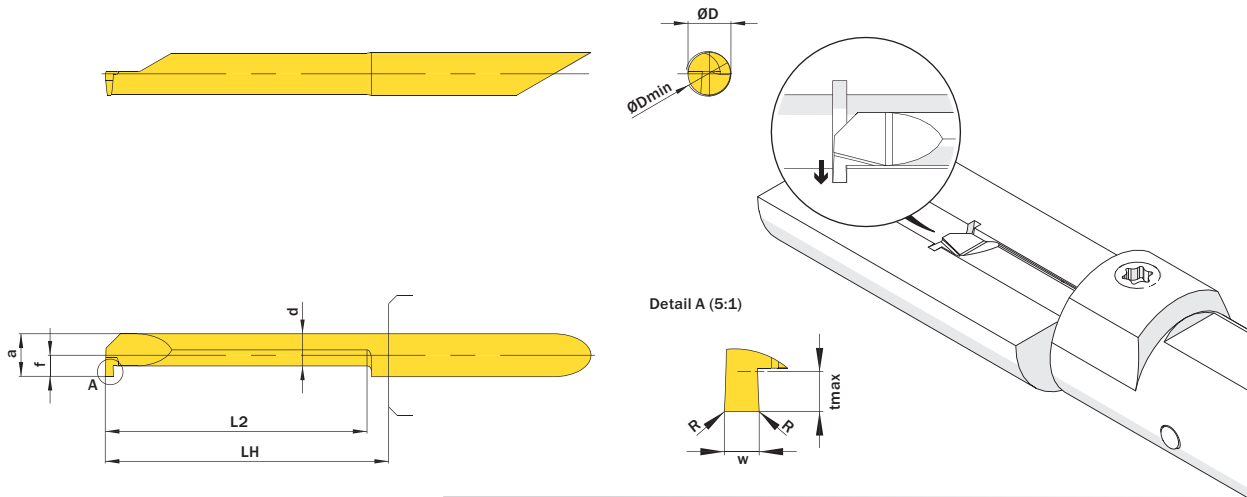
Vergleichbare Werkzeuge auf Seite // Similar tools on page

102



Legende
Legend 139

Scan QR-Code Oder besuchen Sie // Or Visit
www.simtek.info/cp/794



Mehr Informationen zur Kühlmittelzufuhr finden Sie auf Seite 22
Additional information about through coolant supply on page 22

ØD	w ^{+0,03}	L2	ØDmin (Min. Bohrung) ØDmin (min. bore)	Kühlmittelzufuhr Through coolant supply	Artikelnummer Part number	Webcode www.simtek.com/webcode	Unsere erste Wahl Our first choice	a	d	f	LH	R	tmax	Connectcode www.simtek.com/code
mm	mm	mm	mm				P K M N S	mm	mm	mm	mm	mm	mm	

Fortgesetzte Tabelle
Continued Table

Verwandte Werkzeuge finden Sie auch auf der vorhergehenden Seite!
Related Items can be found on the previous page as well!

▼ w = 0,787 mm															
5,0	0,787	10,2	5,2	+	A05.0078.10.52 GR/L	R AD73 L ADME	X800 X400	4,95	3,75	2,45	13,0	-	1,0	R A05.R L A05.L	inch
5,0	0,787	15,2	5,2	+	A05.0078.15.52 GR/L	R AKYB L ANF8	X800 X400	4,95	3,75	2,45	18,0	-	1,0	R A05.R L A05.L	inch
5,0	0,787	20,3	5,2	+	A05.0078.20.52 GR/L	R ANXZ L AE12	X800 X400	4,95	3,75	2,45	23,0	-	1,0	R A05.R L A05.L	inch
5,0	0,787	25,4	5,2	+	A05.0078.25.52 GR/L	R AHZ2 L AG9U	X800 X400	4,95	3,75	2,45	28,0	-	1,0	R A05.R L A05.L	inch
5,0	0,787	30,5	5,2	+	A05.0078.30.52 GR/L	R ADYH L AFFQ	X800 X400	4,95	3,75	2,45	33,0	-	1,0	R A05.R L A05.L	inch
5,0	0,787	35,6	5,2	+	A05.0078.35.52 GR/L	R AGMP L ACT2	X800 X400	4,95	3,75	2,45	38,0	-	1,0	R A05.R L A05.L	inch
▼ w = 1,0 mm															
5,0	1,0	10,2	5,2	+	A05.0100.10.52 GR/L	R AEBC L AFST	X800 X400	4,95	3,75	2,45	13,0	-	1,0	R A05.R L A05.L	
5,0	1,0	15,2	5,2	+	A05.0100.15.52 GR/L	R ADK5 L AA5P	X800 X400	4,95	3,75	2,45	18,0	-	1,0	R A05.R L A05.L	
5,0	1,0	20,3	5,2	+	A05.0100.20.52 GR/L	R AAXA L AH69	X800 X400	4,95	3,75	2,45	23,0	-	1,0	R A05.R L A05.L	
5,0	1,0	25,4	5,2	+	A05.0100.25.52 GR/L	R AGA3 L ADBV	X800 X400	4,95	3,75	2,45	28,0	-	1,0	R A05.R L A05.L	
5,0	1,0	30,5	5,2	+	A05.0100.30.52 GR/L	R AKAP L AHB5	X800 X400	4,95	3,75	2,45	33,0	-	1,0	R A05.R L A05.L	
5,0	1,0	35,6	5,2	+	A05.0100.35.52 GR/L	R ABCY L AMGE	X800 X400	4,95	3,75	2,45	38,0	-	1,0	R A05.R L A05.L	
▼ w = 1,168 mm															
5,0	1,168	10,2	5,2	+	A05.0117.10.52 GR/L	R AGK0 L AFMN	X800 X400	4,95	3,75	2,45	13,0	-	1,0	R A05.R L A05.L	inch
5,0	1,168	15,2	5,2	+	A05.0117.15.52 GR/L	R AKC3 L APGJ	X800 X400	4,95	3,75	2,45	18,0	-	1,0	R A05.R L A05.L	inch
5,0	1,168	20,3	5,2	+	A05.0117.20.52 GR/L	R AF9G L AGZA	X800 X400	4,95	3,75	2,45	23,0	-	1,0	R A05.R L A05.L	inch
5,0	1,168	25,4	5,2	+	A05.0117.25.52 GR/L	R AKW7 L AAG8	X800 X400	4,95	3,75	2,45	28,0	-	1,0	R A05.R L A05.L	inch
5,0	1,168	30,5	5,2	+	A05.0117.30.52 GR/L	R ACS4 L AHK1	X800 X400	4,95	3,75	2,45	33,0	-	1,0	R A05.R L A05.L	inch
5,0	1,168	35,6	5,2	+	A05.0117.35.52 GR/L	R AJH3 L ADGE	X800 X400	4,95	3,75	2,45	38,0	-	1,0	R A05.R L A05.L	inch

Verwandte Werkzeuge finden Sie auch auf der folgenden Seite!
Related Items can be found on the following page as well!

Fortgesetzte Tabelle
Continued Table

Bestellbeispiel // Order example: **A05.0100.15.52 GR X800** (R = Rechte Ausführung // Right hand version, X800 = Schneidstoff // Grade)



A05. w, 1/100 mm, 3 Stellen/Digits . L2, 1/1 mm, 2 Stellen/Digits .52. R, 1/100 mm, 3 Stellen/Digits Toleranz // Tolerance R/L
Beispielartikelnummer // Example Part number: **A05.137.15.52.015 XN R** oder // **A05.137.15.52.015 XN L**

Nutenstechen

Geeignet ab Bohrungsdurchmesser 5,2 mm.

Grooving

For use in bores as of minimum bore diameter 5,2 mm.

Schnittwerte (Start) // Cutting parameters (start)

f **0,02 mm/U** Vc **Seite/Page 429**

Passende Klemmhalter auf Seite // Suitable toolholders on page

27, 31, 33, 35, 41, 44, 50, 51, 53, 55, 56, 57, 61, 62, 63, 65, 66, 67, 68, 69

Vergleichbare Werkzeuge auf Seite // Similar tools on page

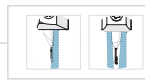
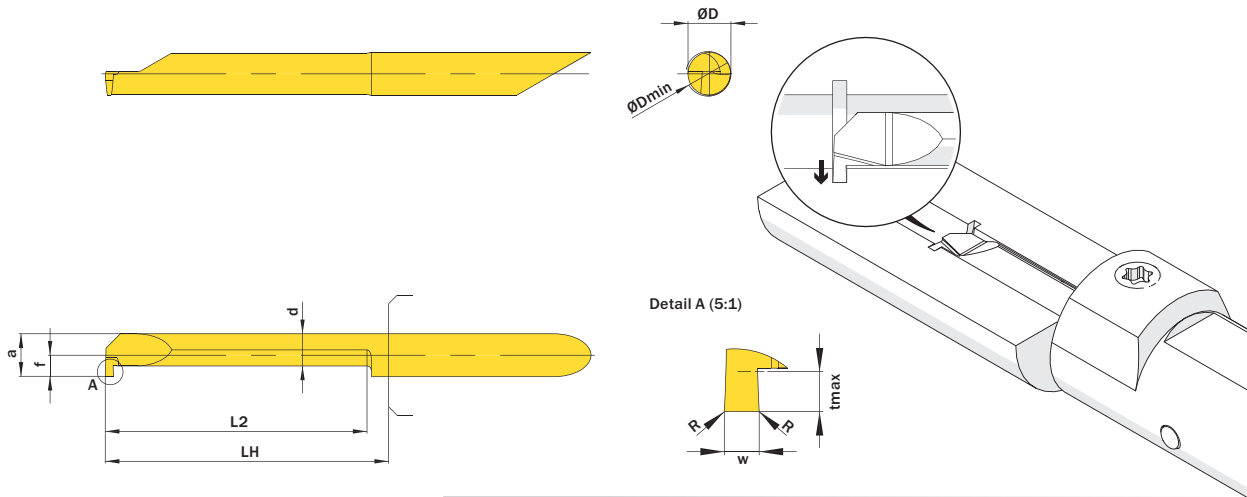
102



SP
HM
R

Legende
Legend **139**

Scan QR-Code Oder besuchen Sie // Or Visit www.simtek.info/cp/795



Mehr Informationen zur Kühlmittelzufuhr finden Sie auf Seite 22
Additional information about through coolant supply on page 22

ØD	w ^{+0,03}	L2	ØDmin (Min. Bohrung) ØDmin (min. bore)	Kühlmittelzufuhr Through coolant supply	Artikelnummer Part number	Webcode www.simtek.com/webcode	Unsere erste Wahl Our first choice	a	d	f	LH	R	tmax	Connectcode www.simtek.com/code
mm	mm	mm	mm				P K M N S	mm	mm	mm	mm	mm	mm	

Fortgesetzte Tabelle
Continued Table

Verwandte Werkzeuge finden Sie auch auf der vorhergehenden Seite!
Related Items can be found on the previous page as well!

▼ w = 1,5 mm														
5,0	1,5	10,2	5,2	+	A05.0150.10.52 GR/L	R AG38 L AFG9C	X800 X400	4,95	3,75	2,45	13,0	-	1,0	R A05.R L A05.L
5,0	1,5	15,2	5,2	+	A05.0150.15.52 GR/L	R ANY8 L AFUK	X800 X400	4,95	3,75	2,45	18,0	-	1,0	R A05.R L A05.L
5,0	1,5	20,3	5,2	+	A05.0150.20.52 GR/L	R AH57 L AJ8D	X800 X400	4,95	3,75	2,45	23,0	-	1,0	R A05.R L A05.L
5,0	1,5	25,4	5,2	+	A05.0150.25.52 GR/L	R AAKF L AFY2	X800 X400	4,95	3,75	2,45	28,0	-	1,0	R A05.R L A05.L
5,0	1,5	30,5	5,2	+	A05.0150.30.52 GR/L	R APVS L ADUG	X800 X400	4,95	3,75	2,45	33,0	-	1,0	R A05.R L A05.L
5,0	1,5	35,6	5,2	+	A05.0150.35.52 GR/L	R AKFJ L AB89	X800 X400	4,95	3,75	2,45	38,0	-	1,0	R A05.R L A05.L
▼ w = 1,575 mm														
5,0	1,575	10,2	5,2	+	A05.0157.10.52 GR/L	R APCY L APG8	X800 X400	4,95	3,75	2,45	13,0	-	1,0	R A05.R L A05.L <small>Inch</small>
5,0	1,575	15,2	5,2	+	A05.0157.15.52 GR/L	R AMD4 L AHMW	X800 X400	4,95	3,75	2,45	18,0	-	1,0	R A05.R L A05.L <small>Inch</small>
5,0	1,575	20,3	5,2	+	A05.0157.20.52 GR/L	R AE6P L APUC	X800 X400	4,95	3,75	2,45	23,0	-	1,0	R A05.R L A05.L <small>Inch</small>
5,0	1,575	25,4	5,2	+	A05.0157.25.52 GR/L	R AFY0 L AHMY	X800 X400	4,95	3,75	2,45	28,0	-	1,0	R A05.R L A05.L <small>Inch</small>
5,0	1,575	30,5	5,2	+	A05.0157.30.52 GR/L	R AJ06 L AFPD	X800 X400	4,95	3,75	2,45	33,0	-	1,0	R A05.R L A05.L <small>Inch</small>
▼ w = 1,981 mm														
5,0	1,981	10,2	5,2	+	A05.0198.10.52 GR/L	R AJ4G L AGND	X800 X400	4,95	3,75	2,45	13,0	-	1,0	R A05.R L A05.L <small>Inch</small>
5,0	1,981	15,2	5,2	+	A05.0198.15.52 GR/L	R ABHH L ANBC	X800 X400	4,95	3,75	2,45	18,0	-	1,0	R A05.R L A05.L <small>Inch</small>
5,0	1,981	20,3	5,2	+	A05.0198.20.52 GR/L	R ACFG L AEM3	X800 X400	4,95	3,75	2,45	23,0	-	1,0	R A05.R L A05.L <small>Inch</small>
5,0	1,981	25,4	5,2	+	A05.0198.25.52 GR/L	R ABS3 L AJZV	X800 X400	4,95	3,75	2,45	28,0	-	1,0	R A05.R L A05.L <small>Inch</small>
5,0	1,981	30,5	5,2	+	A05.0198.30.52 GR/L	R AJNV L ABNQ	X800 X400	4,95	3,75	2,45	33,0	-	1,0	R A05.R L A05.L <small>Inch</small>
5,0	1,981	30,5	5,2	+	A05.0198.30.52.10 GR	A6FB	X800 X400	4,95	3,75	2,45	33,0	0,1	1,0	A05.R <small>Inch new</small>

Verwandte Werkzeuge finden Sie auch auf der folgenden Seite!
Related Items can be found on the following page as well!

Fortgesetzte Tabelle
Continued Table

Bestellbeispiel // Order example: **A05.0157.20.52 GR X800** (R = Rechte Ausführung // Right hand version, X800 = Schneidstoff // Grade)

Nutenstechen

Geeignet ab Bohrungsdurchmesser 5,2 mm.

Grooving

For use in bores as of minimum bore diameter 5,2 mm.

Schnittwerte (Start) // Cutting parameters (start)

f	Vc
0,02 mm/U	Seite/Page 429

Passende Klemmhalter auf Seite // Suitable toolholders on page

27, 28, 31, 33, 35, 36, 41, 42, 44,
45, 50, 51, 53, 55, 56, 57, 58, 61,
62, 63, 64, 65, 66, 67, 68, 69

Vergleichbare Werkzeuge auf Seite // Similar tools on page
102

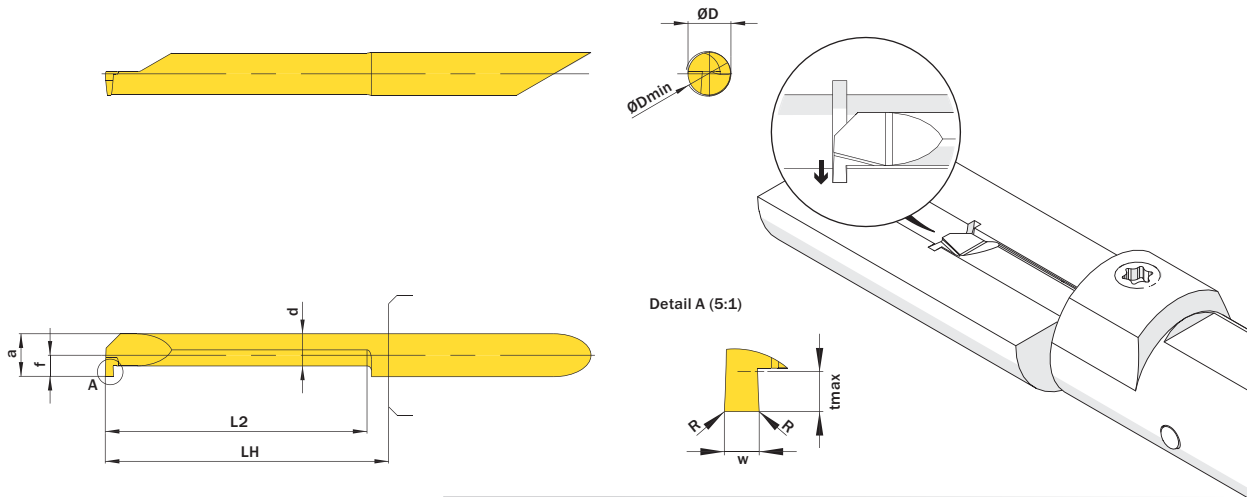


Legende
Legend 139



Scan
QR-Code

Oder besuchen Sie // Or Visit
www.simtek.info/cp/796



Mehr Informationen zur Kühlmittelzufuhr finden Sie auf Seite 22
Additional information about through coolant supply on page 22

ØD	w ^{+0,03}	L2	ØDmin (Min. Bohrung) ØDmin (min. bore)	Kühlmittelzufuhr Through coolant supply	Artikelnummer Part number	Webcode www.simtek.com/webcode	Unsere erste Wahl Our first choice	a	d	f	LH	R	tmax	Connectcode www.simtek.com/code
mm	mm	mm	mm				P K M N S	mm	mm	mm	mm	mm	mm	

Fortgesetzte Tabelle
Continued Table

Verwandte Werkzeuge finden Sie auch auf der vorhergehenden Seite!
Related items can be found on the previous page as well!

▼ ØD = 5,0 mm																						
5,0	2,0	10,2	5,2	+	A05.0200.10.52 GR/L	R	AEKP	L	ABTY	X800	X400	4,95	3,75	2,45	13,0	-	1,0	R	A05.R	L	A05.L	
5,0	2,0	15,2	5,2	+	A05.0200.15.52 GR/L	R	ACHW	L	AA3V	X800	X400	4,95	3,75	2,45	18,0	-	1,0	R	A05.R	L	A05.L	
5,0	2,0	20,3	5,2	+	A05.0200.20.52 GR/L	R	AHTZ	L	AJX6	X800	X400	4,95	3,75	2,45	23,0	-	1,0	R	A05.R	L	A05.L	
5,0	2,0	25,4	5,2	+	A05.0200.25.52 GR/L	R	AMKP	L	AMNF	X800	X400	4,95	3,75	2,45	28,0	-	1,0	R	A05.R	L	A05.L	
5,0	2,0	30,5	5,2	+	A05.0200.30.52 GR/L	R	AF7J	L	AHFX	X800	X400	4,95	3,75	2,45	33,0	-	1,0	R	A05.R	L	A05.L	
▼ ØD = 6,0 mm																						
6,0	0,787	10,2	6,2	+	A06.0078.10.62 GR/L	R	AC9Z	L	AMAW	X800	X400	5,95	3,95	2,95	13,0	-	1,8	R	A06.R	L	A06.L	inch
6,0	0,787	15,2	6,2	+	A06.0078.15.62 GR/L	R	AN1C	L	AGWT	X800	X400	5,95	3,95	2,95	18,0	-	1,8	R	A06.R	L	A06.L	inch
6,0	0,787	20,3	6,2	+	A06.0078.20.62 GR/L	R	AFQZ	L	AFX4	X800	X400	5,95	3,95	2,95	23,0	-	1,8	R	A06.R	L	A06.L	inch
6,0	0,787	25,4	6,2	+	A06.0078.25.62 GR/L	R	AGDØ	L	AJZ5	X800	X400	5,95	3,95	2,95	28,0	-	1,8	R	A06.R	L	A06.L	inch
6,0	0,787	30,5	6,2	+	A06.0078.30.62 GR/L	R	ACZD	L	AMXV	X800	X400	5,95	3,95	2,95	33,0	-	1,8	R	A06.R	L	A06.L	inch
6,0	0,787	35,6	6,2	+	A06.0078.35.62 GR/L	R	ADAE	L	AKZG	X800	X400	5,95	3,95	2,95	38,0	-	1,8	R	A06.R	L	A06.L	inch

Verwandte Werkzeuge finden Sie auch auf der folgenden Seite!
Related items can be found on the following page as well!

Fortgesetzte Tabelle
Continued Table

Bestellbeispiel // Order example: **A06.0078.20.62 GR X800** (R = Rechte Ausführung // Right hand version, X800 = Schneidstoff // Grade)



A05. [w. 1/100 mm, 3 Stellen/Digits](#) . [L2, 1/1 mm, 2 Stellen/Digits](#) .52. [R, 1/100 mm, 3 Stellen/Digits](#) Toleranz // Tolerance R/L
Beispielartikelnummer // Example Part number: **A05.137.15.52.015 XN R** oder/ or **A05.137.15.52.015 XN L**



A05. [w. 1/100 mm, 3 Stellen/Digits](#) . [L2, 1/1 mm, 2 Stellen/Digits](#) .52. [R, 1/100 mm, 3 Stellen/Digits](#) Toleranz // Tolerance R/L
Beispielartikelnummer // Example Part number: **A05.137.15.52.015 XN R** oder/ or **A05.137.15.52.015 XN L**

A06. [w. 1/100 mm, 3 Stellen/Digits](#) . [L2, 1/1 mm, 2 Stellen/Digits](#) .62. [R, 1/100 mm, 3 Stellen/Digits](#) Toleranz // Tolerance R/L
Beispielartikelnummer // Example Part number: **A06.137.15.62.015 XN R** oder/ or **A06.137.15.62.015 XN L**

Nutenstechen

Geeignet ab Bohrungsdurchmesser 6,2 mm.

Grooving

For use in bores as of minimum bore diameter 6,2 mm.

Schnittwerte (Start) // Cutting parameters (start)

f **0,02 mm/U** Vc **Seite/Page 429**

Passende Klemmhalter auf Seite // Suitable toolholders on page

28, 31, 36, 42, 45, 50, 51, 53, 55, 56, 58, 61, 62, 64, 65, 66, 67, 68, 69

Vergleichbare Werkzeuge auf Seite // Similar tools on page

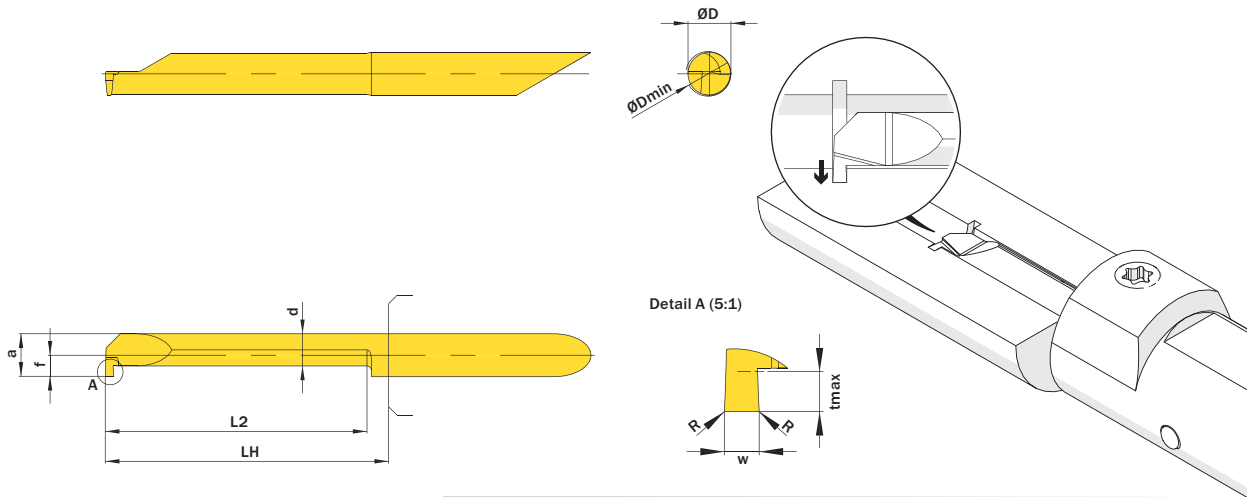
102



SP
HM
R

Legende
Legend **139**

Scan QR-Code Oder besuchen Sie // Or Visit www.simtek.info/cp/797



Mehr Informationen zur Kühlmittelzufuhr finden Sie auf Seite 22
Additional information about through coolant supply on page 22

ØD	w ^{+0,03}	L2	ØDmin (Min. Bohrung) ØDmin (min. bore)	Kühlmittelzufuhr Through coolant supply	Artikelnummer Part number	Webcode www.simtek.com/webcode	Unsere erste Wahl Our first choice	a	d	f	LH	R	tmax	Connectcode www.simtek.com/code
mm	mm	mm	mm				P K M N S	mm	mm	mm	mm	mm	mm	

Fortgesetzte Tabelle
Continued Table

Verwandte Werkzeuge finden Sie auch auf der vorhergehenden Seite!
Related Items can be found on the previous page as well!

▼ w = 1,0 mm														
6,0	1,0	10,2	6,2	+	A06.0100.10.62 GR/L	R APGK L ADY2	X800 X400	5,95	3,95	2,95	13,0	-	1,8	R A06.R L A06.L
6,0	1,0	15,2	6,2	+	A06.0100.15.62 GR/L	R ACW8 L AH38	X800 X400	5,95	3,95	2,95	18,0	-	1,8	R A06.R L A06.L
6,0	1,0	20,3	6,2	+	A06.0100.20.62 GR/L	R AJE6 L ADE3	X800 X400	5,95	3,95	2,95	23,0	-	1,8	R A06.R L A06.L
6,0	1,0	25,4	6,2	+	A06.0100.25.62 GR/L	R AJXT L AKE0	X800 X400	5,95	3,95	2,95	28,0	-	1,8	R A06.R L A06.L
6,0	1,0	30,5	6,2	+	A06.0100.30.62 GR/L	R AH78 L AK9S	X800 X400	5,95	3,95	2,95	33,0	-	1,8	R A06.R L A06.L
6,0	1,0	35,6	6,2	+	A06.0100.35.62 GR/L	R AJ2E L AF63	X800 X400	5,95	3,95	2,95	38,0	-	1,8	R A06.R L A06.L
6,0	1,0	40,6	6,2	+	A06.0100.40.62 GR/L	R AKTD L AN3W	X800 X400	5,95	3,95	2,95	43,0	-	1,8	R A06.R L A06.L
▼ w = 1,168 mm														
6,0	1,168	10,2	6,2	+	A06.0117.10.62 GR/L	R AG4P L AFAB	X800 X400	5,95	3,95	2,95	13,0	-	1,8	R A06.R L A06.L <small>inch</small>
6,0	1,168	10,2	6,2	+	A06.0117.10.62.10 GR	A5KT	X800 X400	5,95	3,95	2,95	13,0	0,1	1,8	A06.R <small>new inch</small>
6,0	1,168	15,2	6,2	+	A06.0117.15.62 GR/L	R ADAP L AA2N	X800 X400	5,95	3,95	2,95	18,0	-	1,8	R A06.R L A06.L <small>inch</small>
6,0	1,168	20,3	6,2	+	A06.0117.20.62 GR/L	R ADH8 L ACUT	X800 X400	5,95	3,95	2,95	23,0	-	1,8	R A06.R L A06.L <small>inch</small>
6,0	1,168	25,4	6,2	+	A06.0117.25.62 GR/L	R AC61 L APFG	X800 X400	5,95	3,95	2,95	28,0	-	1,8	R A06.R L A06.L <small>inch</small>
6,0	1,168	30,5	6,2	+	A06.0117.30.62 GR/L	R AFN5 L AHPK	X800 X400	5,95	3,95	2,95	33,0	-	1,8	R A06.R L A06.L <small>inch</small>
6,0	1,168	35,6	6,2	+	A06.0117.35.62 GR/L	R APS7 L ANN2	X800 X400	5,95	3,95	2,95	38,0	-	1,8	R A06.R L A06.L <small>inch</small>
6,0	1,168	40,6	6,2	+	A06.0117.40.62 GR/L	R AA06 L APY3	X800 X400	5,95	3,95	2,95	43,0	-	1,8	R A06.R L A06.L <small>inch</small>

Verwandte Werkzeuge finden Sie auch auf der folgenden Seite!
Related Items can be found on the following page as well!

Fortgesetzte Tabelle
Continued Table

Bestellbeispiel // Order example: **A06.0100.20.62 GR X800** (R = Rechte Ausführung // Right hand version, X800 = Schneidstoff // Grade)

Nutenstechen

Geeignet ab Bohrungsdurchmesser 6,2 mm.

Grooving

For use in bores as of minimum bore diameter 6,2 mm.

Schnittwerte (Start) // Cutting parameters (start)

f	Vc
0,02 mm/U	Seite/Page 429

Passende Klemmhalter auf Seite // Suitable toolholders on page

28, 31, 36, 42, 45, 50, 51, 53, 55,
56, 58, 61, 62, 64, 65, 66, 67, 68,
69

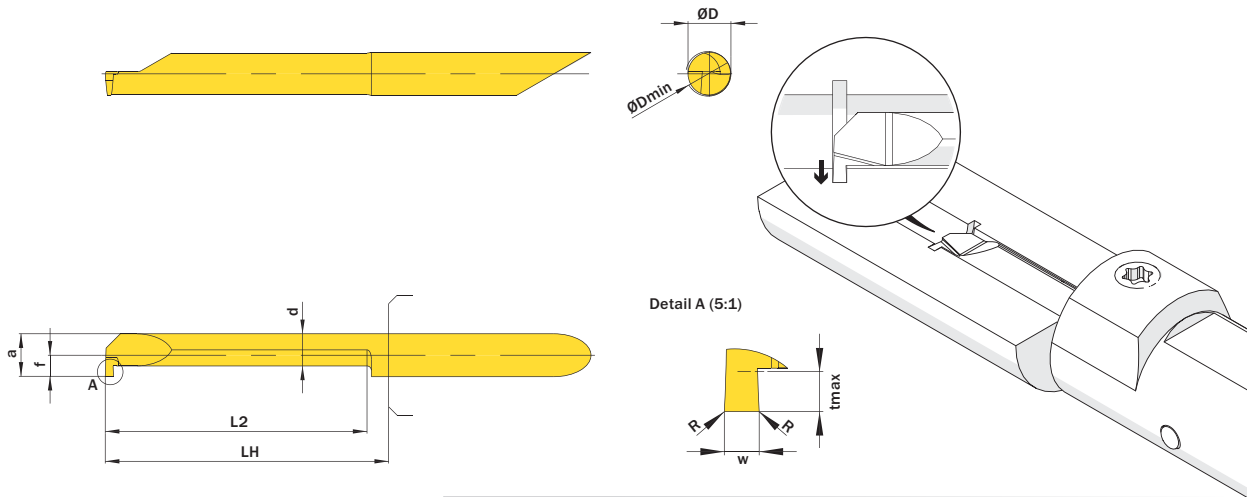
Vergleichbare Werkzeuge auf Seite // Similar tools on page

102



Legende
Legend 139

Scan QR-Code Oder besuchen Sie // Or Visit
www.simtek.info/cp/798



Mehr Informationen zur Kühlmittelzufuhr finden Sie auf Seite 22
Additional information about through coolant supply on page 22

ØD	w ^{+0,03}	L2	ØDmin (Min. Bohrung) ØDmin (min. bore)	Kühlmittelzufuhr Through coolant supply	Artikelnummer Part number	Webcode www.simtek.com/webcode	Unsere erste Wahl Our first choice	a	d	f	LH	R	tmax	Connectcode www.simtek.com/code
mm	mm	mm	mm				P K M N S	mm	mm	mm	mm	mm	mm	

Fortgesetzte Tabelle
Continued Table

Verwandte Werkzeuge finden Sie auch auf der vorhergehenden Seite!
Related items can be found on the previous page as well!

▼ w = 1,5 mm																				
6,0	1,5	10,2	6,2	+	A06.0150.10.62 GR/L	R	ACH4	L	ADTA	X800 X400	5,95	3,95	2,95	13,0	-	1,8	R	A06.R	L	A06.L
6,0	1,5	15,2	6,2	+	A06.0150.15.62 GR/L	R	ADPJ	L	AKTA	X800 X400	5,95	3,95	2,95	18,0	-	1,8	R	A06.R	L	A06.L
6,0	1,5	20,3	6,2	+	A06.0150.20.62 GR/L	R	AFH9	L	AF35	X800 X400	5,95	3,95	2,95	23,0	-	1,8	R	A06.R	L	A06.L
6,0	1,5	25,4	6,2	+	A06.0150.25.62 GR/L	R	AFHV	L	AJØP	X800 X400	5,95	3,95	2,95	28,0	-	1,8	R	A06.R	L	A06.L
6,0	1,5	30,5	6,2	+	A06.0150.30.62 GR/L	R	ANT7	L	AGBØ	X800 X400	5,95	3,95	2,95	33,0	-	1,8	R	A06.R	L	A06.L
6,0	1,5	35,6	6,2	+	A06.0150.35.62 GR/L	R	ACUC	L	APT7	X800 X400	5,95	3,95	2,95	38,0	-	1,8	R	A06.R	L	A06.L
▼ w = 1,575 mm																				
6,0	1,575	10,2	6,2	+	A06.0157.10.62 GR/L	R	AES5	L	AK6U	X800 X400	5,95	3,95	2,95	13,0	-	1,8	R	A06.R	L	A06.L
6,0	1,575	15,2	6,2	+	A06.0157.15.62 GR/L	R	AJAB	L	AJYH	X800 X400	5,95	3,95	2,95	18,0	-	1,8	R	A06.R	L	A06.L
6,0	1,575	20,3	6,2	+	A06.0157.20.62 GR/L	R	ADAB	L	AJBY	X800 X400	5,95	3,95	2,95	23,0	-	1,8	R	A06.R	L	A06.L
6,0	1,575	25,4	6,2	+	A06.0157.25.62 GR/L	R	AJFE	L	AAAE	X800 X400	5,95	3,95	2,95	28,0	-	1,8	R	A06.R	L	A06.L
6,0	1,575	30,5	6,2	+	A06.0157.30.62 GR/L	R	AK3J	L	AK1G	X800 X400	5,95	3,95	2,95	33,0	-	1,8	R	A06.R	L	A06.L
6,0	1,575	35,6	6,2	+	A06.0157.35.62 GR/L	R	AMBZ	L	AHSN	X800 X400	5,95	3,95	2,95	38,0	-	1,8	R	A06.R	L	A06.L
6,0	1,575	40,6	6,2	+	A06.0157.40.62 GR/L	R	AG12	L	AH5K	X800 X400	5,95	3,95	2,95	43,0	-	1,8	R	A06.R	L	A06.L

Verwandte Werkzeuge finden Sie auch auf der folgenden Seite!
Related items can be found on the following page as well!

Fortgesetzte Tabelle
Continued Table

Bestellbeispiel // Order example: **A06.0150.20.62 GR X800** (R = Rechte Ausführung // Right hand version, X800 = Schneidstoff // Grade)



A06. w, 1/100 mm, 3 Stellen/Digits . L2, 1/1 mm, 2 Stellen/Digits .62. R, 1/100 mm, 3 Stellen/Digits Toleranz // Tolerance R/L
Beispielartikelnummer // Example Part number: **A06.137.15.62.015 XN R** oder/ or **A06.137.15.62.015 XN L**

Nutenstechen

Geeignet ab Bohrungsdurchmesser 6,2 mm.

Grooving

For use in bores as of minimum bore diameter 6,2 mm.

Schnittwerte (Start) // Cutting parameters (start)

f	Vc
0,02 mm/U	Seite/Page 429

Passende Klemmhalter auf Seite // Suitable toolholders on page

28, 29, 31, 36, 37, 42, 45, 46, 50, 51, 52, 53, 54, 55, 56, 58, 61, 62, 64, 65, 66, 67, 68, 69

Vergleichbare Werkzeuge auf Seite // Similar tools on page

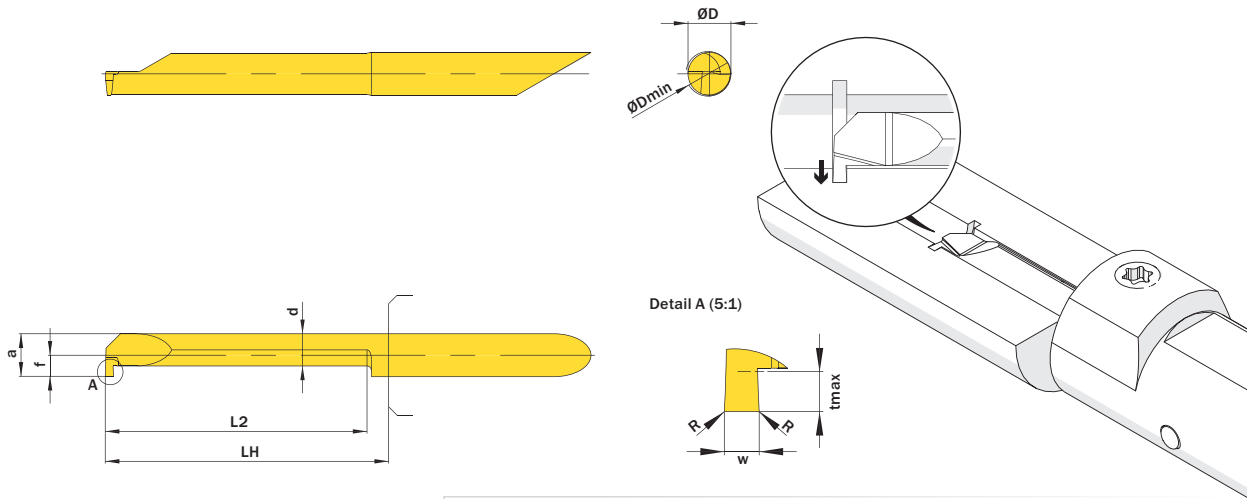
102



SP
HM
R

Legende
Legend 139

Scan QR-Code Oder besuchen Sie // Or Visit
www.simtek.info/cp/799



Mehr Informationen zur Kühlmittelzufuhr finden Sie auf Seite 22
Additional information about through coolant supply on page 22

ØD	w ^{+0,03}	L2	ØDmin (Min. Bohrung) ØDmin (min. bore)	Kühlmittelzufuhr Through coolant supply	Artikelnummer Part number	Webcode www.simtek.com/webcode	Unsere erste Wahl Our first choice	a	d	f	LH	R	tmax	Connectcode www.simtek.com/code
mm	mm	mm	mm				P K M N S	mm	mm	mm	mm	mm	mm	

Fortgesetzte Tabelle Continued Table		Verwandte Werkzeuge finden Sie auch auf der vorhergehenden Seite! Related Items can be found on the previous page as well!													
6,0	1,981	10,2	6,2	+	A06.0198.10.62 GR/L	R AH4X L AJBE X800 X400		5,95	3,95	2,95	13,0	-	1,8	R A06.R L A06.L	inch
6,0	1,981	15,2	6,2	+	A06.0198.15.62 GR/L	R AE9F L ANK9 X800 X400		5,95	3,95	2,95	18,0	-	1,8	R A06.R L A06.L	inch
6,0	1,981	20,3	6,2	+	A06.0198.20.62 GR/L	R AXVN L AFQQ X800 X400		5,95	3,95	2,95	23,0	-	1,8	R A06.R L A06.L	inch
6,0	1,981	25,4	6,2	+	A06.0198.25.62 GR/L	R AJAX L AMQM X800 X400		5,95	3,95	2,95	28,0	-	1,8	R A06.R L A06.L	inch
6,0	1,981	30,5	6,2	+	A06.0198.30.62 GR/L	R AJCJ L APFQ X800 X400		5,95	3,95	2,95	33,0	-	1,8	R A06.R L A06.L	inch
6,0	1,981	30,5	6,2	+	A06.0198.30.62.10 GR	A6E9 X800 X400		5,95	3,95	2,95	33,0	0,1	1,8	A06.R	new inch
6,0	1,981	35,6	6,2	+	A06.0198.35.62 GR/L	R A08P L A08Q X800 X400		5,95	3,95	2,95	38,0	-	1,8	R A06.R L A06.L	inch
6,0	2,0	10,2	6,2	+	A06.0200.10.62 GR/L	R ABY8 L AK2Q X800 X400		5,95	3,95	2,95	13,0	-	1,8	R A06.R L A06.L	inch
6,0	2,0	15,2	6,2	+	A06.0200.15.62 GR/L	R AFYP L AEUP X800 X400		5,95	3,95	2,95	18,0	-	1,8	R A06.R L A06.L	inch
6,0	2,0	20,3	6,2	+	A06.0200.20.62 GR/L	R AB0S L AHN0 X800 X400		5,95	3,95	2,95	23,0	-	1,8	R A06.R L A06.L	inch
6,0	2,0	25,4	6,2	+	A06.0200.25.62 GR/L	R APT6 L AC9V X800 X400		5,95	3,95	2,95	28,0	-	1,8	R A06.R L A06.L	inch
6,0	2,0	30,5	6,2	+	A06.0200.30.62 GR/L	R AC74 L ANMU X800 X400		5,95	3,95	2,95	33,0	-	1,8	R A06.R L A06.L	inch
7,0	0,787	10,2	7,2	+	A07.0078.10.72 GR/L	R ANFU L ACZM X800 X400		6,95	4,25	3,45	13,0	-	2,5	R A07.R L A07.L	inch
7,0	0,787	15,2	7,2	+	A07.0078.15.72 GR/L	R AJB8 L AF8M X800 X400		6,95	4,25	3,45	18,0	-	2,5	R A07.R L A07.L	inch
7,0	0,787	20,3	7,2	+	A07.0078.20.72 GR/L	R AG21 L ACUK X800 X400		6,95	4,25	3,45	23,0	-	2,5	R A07.R L A07.L	inch
7,0	0,787	25,4	7,2	+	A07.0078.25.72 GR/L	R AJM7 L AM36 X800 X400		6,95	4,25	3,45	28,0	-	2,5	R A07.R L A07.L	inch
7,0	0,787	30,5	7,2	+	A07.0078.30.72 GR/L	R ABTA L APCD X800 X400		6,95	4,25	3,45	33,0	-	2,5	R A07.R L A07.L	inch
7,0	0,787	35,6	7,2	+	A07.0078.35.72 GR/L	R ABGT L APCH X800 X400		6,95	4,25	3,45	38,0	-	2,5	R A07.R L A07.L	inch
7,0	0,787	40,6	7,2	+	A07.0078.40.72 GR/L	R ANWX L AJ42 X800 X400		6,95	4,25	3,45	43,0	-	2,5	R A07.R L A07.L	inch

Verwandte Werkzeuge finden Sie auch auf der folgenden Seite!
Related Items can be found on the following page as well!

Fortgesetzte Tabelle
Continued Table

Bestellbeispiel // Order example: A06.0200.10.62 GR X800 (R = Rechte Ausführung // Right hand version, X800 = Schneidstoff // Grade)

simtek individual

A06. w, 1/100 mm, 3 Stellen/Digits . L2, 1/1 mm, 2 Stellen/Digits .52. R, 1/100 mm, 3 Stellen/Digits Toleranz // Tolerance R/L

Beispielartikelnummer // Example Part number: A06.137.15.62.015 XN R oder // or A06.137.15.62.015 XN L

simtek individual

A07. w, 1/100 mm, 3 Stellen/Digits . L2, 1/1 mm, 2 Stellen/Digits .62. R, 1/100 mm, 3 Stellen/Digits Toleranz // Tolerance R/L

Beispielartikelnummer // Example Part number: A07.137.15.72.015 XN R oder // or A07.137.15.72.015 XN L

Nutenstechen

Geeignet ab Bohrungsdurchmesser 7,2 mm.

Grooving

For use in bores as of minimum bore diameter 7,2 mm.

Schnittwerte (Start) // Cutting parameters (start)

f	Vc
0,02 mm/U	Seite/Page 429

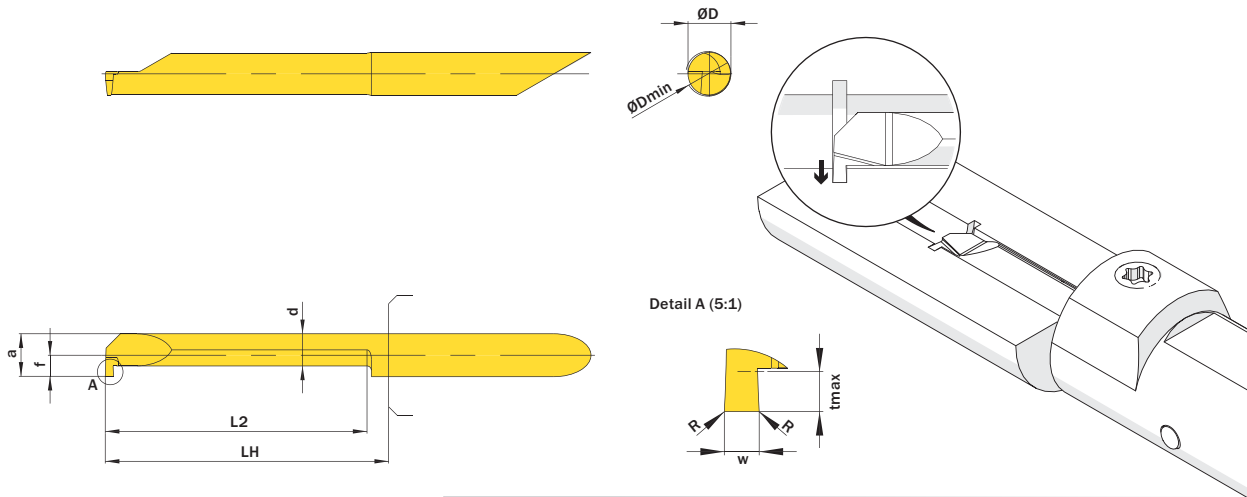
Passende Klemmhalter auf Seite // Suitable toolholders on page
29, 31, 37, 42, 46, 52, 54, 56, 58,
61, 64, 65, 66, 67, 68, 69

Vergleichbare Werkzeuge auf Seite // Similar tools on page
102



Legende
Legend 139

Scan QR-Code Oder besuchen Sie // Or Visit
www.simtek.info/cp/800



Mehr Informationen zur Kühlmittelzufuhr finden Sie auf Seite 22
Additional information about through coolant supply on page 22

ØD	w ^{+0,03}	L2	ØDmin (Min. Bohrung) ØDmin (min. bore)	Kühlmittelzufuhr Through coolant supply	Artikelnummer Part number	Webcode www.simtek.com/webcode	Unsere erste Wahl Our first choice	a	d	f	LH	R	tmax	Connectcode www.simtek.com/code
mm	mm	mm	mm				P K M N S	mm	mm	mm	mm	mm	mm	

Fortgesetzte Tabelle
Continued Table

Verwandte Werkzeuge finden Sie auch auf der vorhergehenden Seite!
Related items can be found on the previous page as well!

▼ w = 1,0 mm																
7,0	1,0	10,2	7,2	+	A07.0100.10.72 GR/L	R AJW1	L AJHP	X800 X400	6,95	4,25	3,45	13,0	-	2,5	R A07.R L A07.L	
7,0	1,0	15,2	7,2	+	A07.0100.15.72 GR/L	R AKT1	L AD20	X800 X400	6,95	4,25	3,45	18,0	-	2,5	R A07.R L A07.L	
7,0	1,0	20,3	7,2	+	A07.0100.20.72 GR/L	R AJ70	L AB35	X800 X400	6,95	4,25	3,45	23,0	-	2,5	R A07.R L A07.L	
7,0	1,0	25,4	7,2	+	A07.0100.25.72 GR/L	R APYK	L AN70	X800 X400	6,95	4,25	3,45	28,0	-	2,5	R A07.R L A07.L	
7,0	1,0	30,5	7,2	+	A07.0100.30.72 GR/L	R AA78	L ADG6	X800 X400	6,95	4,25	3,45	33,0	-	2,5	R A07.R L A07.L	
7,0	1,0	35,6	7,2	+	A07.0100.35.72 GR/L	R AKNF	L AFWS	X800 X400	6,95	4,25	3,45	38,0	-	2,5	R A07.R L A07.L	
7,0	1,0	40,6	7,2	+	A07.0100.40.72 GR/L	R ADSJ	L AHQJ	X800 X400	6,95	4,25	3,45	43,0	-	2,5	R A07.R L A07.L	
▼ w = 1,168 mm																
7,0	1,168	10,2	7,2	+	A07.0117.10.72 GR/L	R AA4H	L AJAH	X800 X400	6,95	4,25	3,45	13,0	-	2,5	R A07.R L A07.L	Inch
7,0	1,168	15,2	7,2	+	A07.0117.15.72 GR/L	R ADV1	L AHJH	X800 X400	6,95	4,25	3,45	18,0	-	2,5	R A07.R L A07.L	Inch
7,0	1,168	20,3	7,2	+	A07.0117.20.72 GR/L	R AHVD	L AE3M	X800 X400	6,95	4,25	3,45	23,0	-	2,5	R A07.R L A07.L	Inch
7,0	1,168	25,4	7,2	+	A07.0117.25.72 GR/L	R ANSE	L ANPE	X800 X400	6,95	4,25	3,45	28,0	-	2,5	R A07.R L A07.L	Inch
7,0	1,168	30,5	7,2	+	A07.0117.30.72 GR/L	R AKKW	L AB8D	X800 X400	6,95	4,25	3,45	33,0	-	2,5	R A07.R L A07.L	Inch
7,0	1,168	35,6	7,2	+	A07.0117.35.72 GR/L	R APF9	L AMQA	X800 X400	6,95	4,25	3,45	38,0	-	2,5	R A07.R L A07.L	Inch
7,0	1,168	40,6	7,2	+	A07.0117.40.72 GR/L	R AFTZ	L AEM7	X800 X400	6,95	4,25	3,45	43,0	-	2,5	R A07.R L A07.L	Inch

Verwandte Werkzeuge finden Sie auch auf der folgenden Seite!
Related items can be found on the following page as well!

Fortgesetzte Tabelle
Continued Table

Bestellbeispiel // Order example: **A07.0100.10.72 GR X800** (R = Rechte Ausführung // Right hand version, X800 = Schneidstoff // Grade)

Nutenstechen

Geeignet ab Bohrungsdurchmesser 7,2 mm.

Grooving

For use in bores as of minimum bore diameter 7,2 mm.

Schnittwerte (Start) // Cutting parameters (start)

f	Vc
0,02 mm/U	Seite/Page 429

Passende Klemmhalter auf Seite // Suitable toolholders on page

29, 31, 37, 42, 46, 52, 54, 56, 58, 61, 64, 65, 66, 67, 68, 69

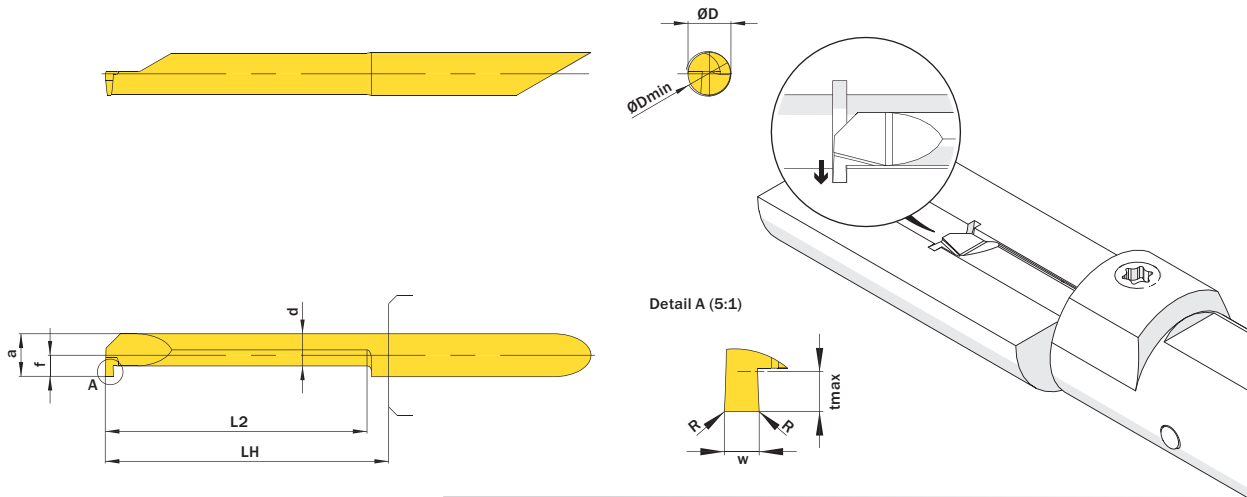
Vergleichbare Werkzeuge auf Seite // Similar tools on page

102



Legende
Legend 139

Scan QR-Code Oder besuchen Sie // Or Visit
www.simtek.info/cp/801



Mehr Informationen zur Kühlmittelzufuhr finden Sie auf Seite 22
Additional information about through coolant supply on page 22

ØD	w ^{+0,03}	L2	ØDmin (Min. Bohrung) ØDmin (min. bore)	Kühlmittelzufuhr Through coolant supply	Artikelnummer Part number	Webcode www.simtek.com/webcode	Unsere erste Wahl Our first choice	a	d	f	LH	R	tmax	Connectcode www.simtek.com/code
mm	mm	mm	mm				P K M N S	mm	mm	mm	mm	mm	mm	

Fortgesetzte Tabelle
Continued Table

Verwandte Werkzeuge finden Sie auch auf der vorhergehenden Seite!
Related items can be found on the previous page as well!

▼ w = 1,5 mm

7,0	1,5	10,2	7,2	+	A07.0150.10.72 GR/L	R AAN7 L AH5P X800 X400	6,95	4,25	3,45	13,0	-	2,5	R A07.R L A07.L
7,0	1,5	15,2	7,2	+	A07.0150.15.72 GR/L	R ACHZ L APC2 X800 X400	6,95	4,25	3,45	18,0	-	2,5	R A07.R L A07.L
7,0	1,5	20,3	7,2	+	A07.0150.20.72 GR/L	R AHXA L ADJB X800 X400	6,95	4,25	3,45	23,0	-	2,5	R A07.R L A07.L
7,0	1,5	25,4	7,2	+	A07.0150.25.72 GR/L	R AJW7 L ANDE X800 X400	6,95	4,25	3,45	28,0	-	2,5	R A07.R L A07.L
7,0	1,5	30,5	7,2	+	A07.0150.30.72 GR/L	R ACNN L ACEZ X800 X400	6,95	4,25	3,45	33,0	-	2,5	R A07.R L A07.L
7,0	1,5	35,6	7,2	+	A07.0150.35.72 GR/L	R AGAX L AG9E X800 X400	6,95	4,25	3,45	38,0	-	2,5	R A07.R L A07.L
7,0	1,5	40,6	7,2	+	A07.0150.40.72 GR/L	R AMH7 L AKM9 X800 X400	6,95	4,25	3,45	43,0	-	2,5	R A07.R L A07.L

▼ w = 1,575 mm

7,0	1,575	10,2	7,2	+	A07.0157.10.72 GR/L	R AP08 L ACYH X800 X400	6,95	4,25	3,45	13,0	-	2,5	R A07.R L A07.L	inch
7,0	1,575	15,2	7,2	+	A07.0157.15.72 GR/L	R AAND L AA4C X800 X400	6,95	4,25	3,45	18,0	-	2,5	R A07.R L A07.L	inch
7,0	1,575	20,3	7,2	+	A07.0157.20.72 GR/L	R AN5Y L AD2K X800 X400	6,95	4,25	3,45	23,0	-	2,5	R A07.R L A07.L	inch
7,0	1,575	25,4	7,2	+	A07.0157.25.72 GR/L	R AKKT L AN6P X800 X400	6,95	4,25	3,45	28,0	-	2,5	R A07.R L A07.L	inch
7,0	1,575	30,5	7,2	+	A07.0157.30.72 GR/L	R ABPX L AHW3 X800 X400	6,95	4,25	3,45	33,0	-	2,5	R A07.R L A07.L	inch
7,0	1,575	35,6	7,2	+	A07.0157.35.72 GR/L	R AMP7 L AMB3 X800 X400	6,95	4,25	3,45	38,0	-	2,5	R A07.R L A07.L	inch
7,0	1,575	40,6	7,2	+	A07.0157.40.72 GR/L	R AFDZ L AKJZ X800 X400	6,95	4,25	3,45	43,0	-	2,5	R A07.R L A07.L	inch

Verwandte Werkzeuge finden Sie auch auf der folgenden Seite!
Related items can be found on the following page as well!

Fortgesetzte Tabelle
Continued Table

Bestellbeispiel // Order example: A07.0150.15.72 GR X800 (R = Rechte Ausführung // Right hand version, X800 = Schneidstoff // Grade)

Nutenstechen

Geeignet ab Bohrungsdurchmesser 7,2 mm.

Grooving

For use in bores as of minimum bore diameter 7,2 mm.

Schnittwerte (Start) // Cutting parameters (start)

f	Vc
0,02 mm/U	Seite/Page 429

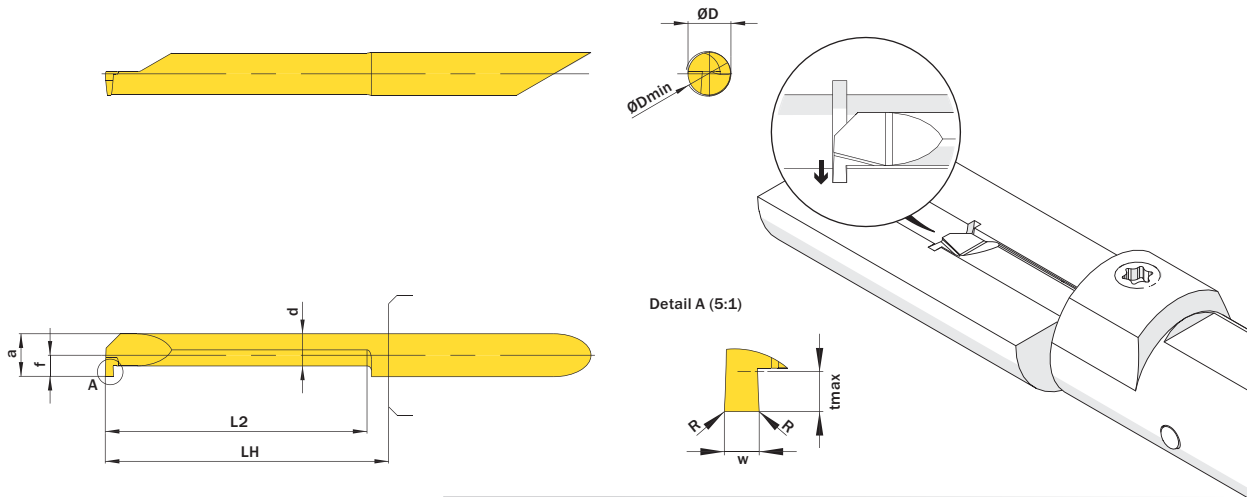
Passende Klemmhalter auf Seite // Suitable toolholders on page
29, 31, 37, 42, 46, 52, 54, 56, 58,
61, 64, 65, 66, 67, 68, 69

Vergleichbare Werkzeuge auf Seite // Similar tools on page
102



Legende
Legend 139

Scan QR-Code Oder besuchen Sie // Or Visit
www.simtek.info/cp/802



Mehr Informationen zur Kühlmittelzufuhr finden Sie auf Seite 22
Additional information about through coolant supply on page 22

ØD	w ^{+0,03}	L2	ØDmin (Min. Bohrung) ØDmin (min. bore)	Kühlmittelzufuhr Through coolant supply	Artikelnummer Part number	Webcode www.simtek.com/webcode	Unsere erste Wahl Our first choice	a	d	f	LH	R	tmax	Connectcode www.simtek.com/code
mm	mm	mm	mm				P K M N S	mm	mm	mm	mm	mm	mm	

Fortgesetzte Tabelle Continued Table
Verwandte Werkzeuge finden Sie auch auf der vorhergehenden Seite!
Related items can be found on the previous page as well!

▼ w = 1,981 mm															
7,0	1,981	10,2	7,2	+	A07.0198.10.72 GR/L	R AHMK L APXC	X800 X400	6,95	4,25	3,45	13,0	-	2,5	R A07.R L A07.L	Inch
7,0	1,981	15,2	7,2	+	A07.0198.15.72 GR/L	R AENX L AM33	X800 X400	6,95	4,25	3,45	18,0	-	2,5	R A07.R L A07.L	Inch
7,0	1,981	20,3	7,2	+	A07.0198.20.72 GR/L	R AEZW L AH9Z	X800 X400	6,95	4,25	3,45	23,0	-	2,5	R A07.R L A07.L	Inch
7,0	1,981	25,4	7,2	+	A07.0198.25.72 GR/L	R AB5B L AHE4	X800 X400	6,95	4,25	3,45	28,0	-	2,5	R A07.R L A07.L	Inch
7,0	1,981	30,5	7,2	+	A07.0198.30.72 GR/L	R AJQG L AHPP	X800 X400	6,95	4,25	3,45	33,0	-	2,5	R A07.R L A07.L	Inch
7,0	1,981	35,6	7,2	+	A07.0198.35.72 GR/L	R AFCM L AF31	X800 X400	6,95	4,25	3,45	38,0	-	2,5	R A07.R L A07.L	Inch
▼ w = 2,0 mm															
7,0	2,0	10,2	7,2	+	A07.0200.10.72 GR/L	R AVF2 L AFA9	X800 X400	6,95	4,25	3,45	13,0	-	2,5	R A07.R L A07.L	
7,0	2,0	15,2	7,2	+	A07.0200.15.72 GR/L	R AEJD L AJMK	X800 X400	6,95	4,25	3,45	18,0	-	2,5	R A07.R L A07.L	
7,0	2,0	20,3	7,2	+	A07.0200.20.72 GR/L	R AAVP L ADHT	X800 X400	6,95	4,25	3,45	23,0	-	2,5	R A07.R L A07.L	
7,0	2,0	25,4	7,2	+	A07.0200.25.72 GR/L	R AGDY L AKJ0	X800 X400	6,95	4,25	3,45	28,0	-	2,5	R A07.R L A07.L	
7,0	2,0	30,5	7,2	+	A07.0200.30.72 GR/L	R AHQQ L APXY	X800 X400	6,95	4,25	3,45	33,0	-	2,5	R A07.R L A07.L	
7,0	2,0	35,6	7,2	+	A07.0200.35.72 GR/L	R AJNM L APD1	X800 X400	6,95	4,25	3,45	38,0	-	2,5	R A07.R L A07.L	

Bestellbeispiel // Order example: A07.0200.20.72 GR X800 (R = Rechte Ausführung // Right hand version, X800 = Schneidstoff // Grade)

simtek individual A07. w, 1/100 mm, 3 Stellen/Digits L2, 1/1 mm, 2 Stellen/Digits .72. R, 1/100 mm, 3 Stellen/Digits Toleranz // Tolerance R/L
Beispielartikelnummer // Example Part number: A07.137.15.72.015 XN R oder/ or A07.137.15.72.015 XN L

Nutenstechen

Geeignet ab Bohrungsdurchmesser 10,5 mm.

Grooving

For use in bores as of minimum bore diameter 10,5 mm.

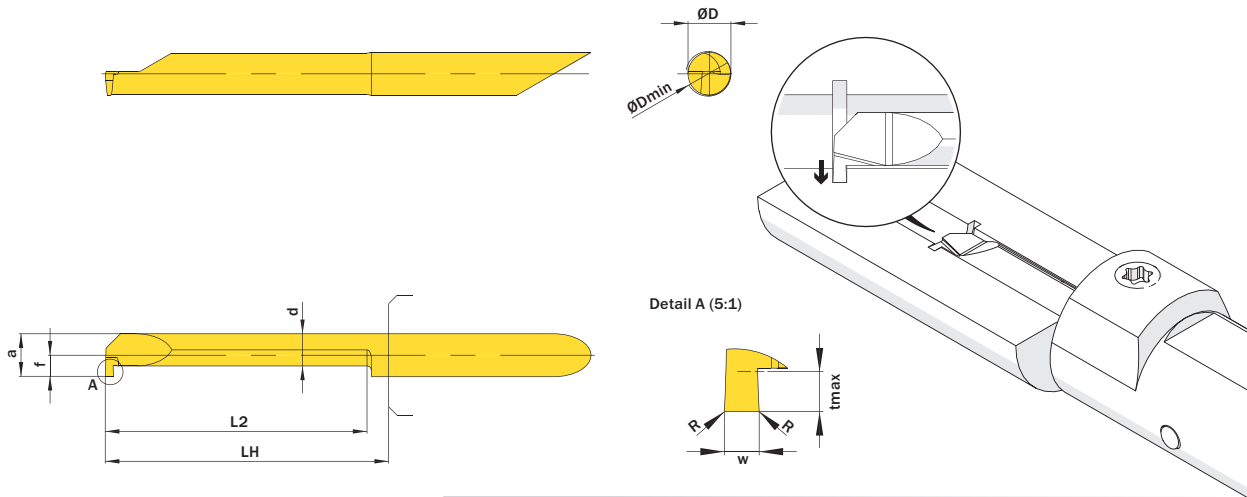
Schnittwerte (Start) // Cutting parameters (start)	
f 0,02 mm/U	Vc Seite/Page 429

Passende Klemmhalter auf Seite // Suitable toolholders on page
30, 39, 48, 52, 54, 59, 68

Vergleichbare Werkzeuge auf Seite // Similar tools on page
102

SP **HM** **R** **Legende Legend 139**

Scan QR-Code Oder besuchen Sie // Or Visit www.simtek.info/cp/1120



Mehr Informationen zur Kühlmittelzufuhr finden Sie auf Seite 22
Additional information about through coolant supply on page 22

ØD	w ^{+0,03}	L2	ØDmin (Min. Bohrung) ØDmin (min. bore)	Kühlmittelzufuhr Through coolant supply	Artikelnummer Part number	Webcode www.simtek.com/webcode	Unsere erste Wahl Our first choice	a	d	f	LH	R	tmax	Connectcode www.simtek.com/code
mm	mm	mm	mm				P K M N S	mm	mm	mm	mm	mm	mm	
▼ w = 1,0 mm														
10,0	1,0	30,5	10,5	+	A10.0100.30.10 GR/L	R AYEJ L AYEH	X800 X400	9,95	5,45	4,95	33,0	-	4,0	R A10.R L A10.L
10,0	1,0	50,8	10,5	+	A10.0100.50.10 GR/L	R AYEM L AYEK	X800 X400	9,95	5,45	4,95	53,0	-	4,0	R A10.R L A10.L
▼ w = 2,0 mm														
10,0	2,0	30,5	10,5	+	A10.0200.30.10 GR/L	R AYEP L AYEN	X800 X400	9,95	5,45	4,95	33,0	-	4,0	R A10.R L A10.L
10,0	2,0	50,8	10,5	+	A10.0200.50.10 GR/L	R AYES L AYEQ	X800 X400	9,95	5,45	4,95	53,0	-	4,0	R A10.R L A10.L
▼ w = 3,0 mm														
10,0	3,0	30,5	10,5	+	A10.0300.30.10 GR/L	R AYEU L AYET	X800 X400	9,95	5,45	4,95	33,0	-	4,0	R A10.R L A10.L
10,0	3,0	50,8	10,5	+	A10.0300.50.10 GR/L	R AT6F L AYEY	X800 X400	9,95	5,45	4,95	53,0	-	4,0	R A10.R L A10.L

Bestellbeispiel // Order example: **A10.0200.30.10 GR X800** (R = Rechte Ausführung // Right hand version, X800 = Schneidstoff // Grade)

simturn AX
simturn DX
simturn PX
simturn H2
simturn K2
simturn C4
simturn GX
simturn E3
simturn E12
simturn FX
simturn Decolletage
simturn OA
Index

Stechen von Vollradiusnuten

Geeignet ab Bohrungsdurchmesser 4,2 mm.

Full Radius Grooving

For use in bores as of minimum bore diameter 4,2 mm.

Schnittwerte (Start) // Cutting parameters (start)

f	Vc
0,02 mm/U	Seite/Page 429

Passende Klemmhalter auf Seite // Suitable toolholders on page

27, 28, 31, 32, 33, 34, 35, 36, 40,
41, 42, 43, 44, 45, 50, 51, 53, 55,
56, 57, 58, 60, 61, 62, 63, 64, 65,
66, 67, 68, 69



SP
HM
R

Legende
Legend 139

Scan QR-Code Oder besuchen Sie // Or Visit
www.simtek.info/cp/778

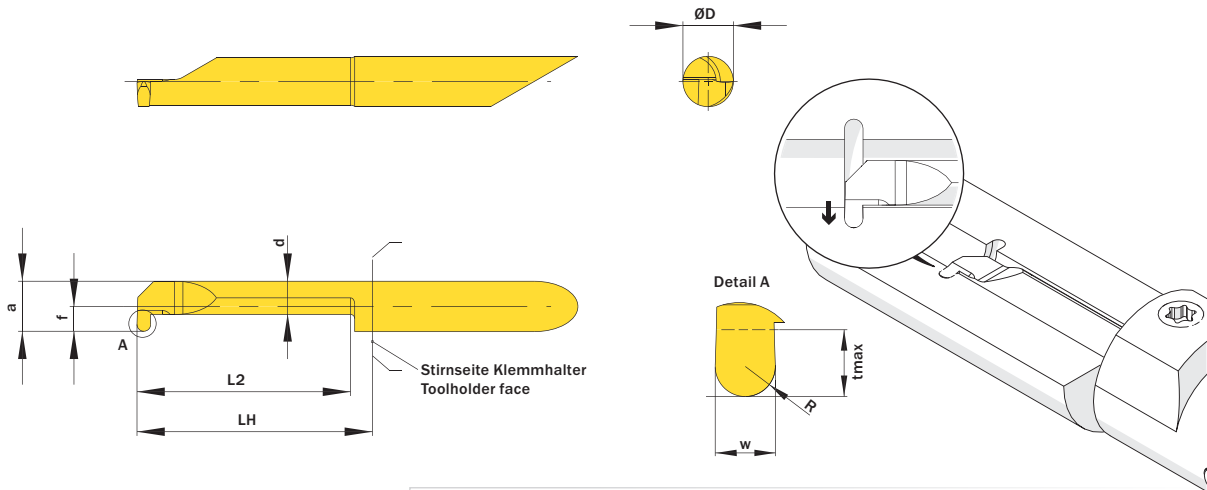


Abbildung zeigt / Drawing shows: A06.0150.25.62 VR

Mehr Informationen zur Kühlmittelzufuhr finden Sie auf Seite 22
Additional information about through coolant supply on page 22

ØD	w ^{+0,03}	L2	ØDmin (Min. Bohrung) ØDmin (min. bore)	Kühlmittelzufuhr Through coolant supply	Artikelnummer Part number	Webcode www.simtek.com/webcode	Unsere erste Wahl Our first choice	a	d	f	LH	R	tmax	Connectcode www.simtek.com/code
mm	mm	mm	mm				P K M N S	mm	mm	mm	mm	mm	mm	
▼ ØD = 4,0 mm														
4,0	1,0	15,2	4,2	+	A04.0100.15.42 VR/L	R AC9G L ACXS	X800 X400	3,95	2,95	1,95	18,0	0,5	0,8	R A04C.R L A04C.L
4,0	1,168	15,2	4,2	+	A04.0117.15.42 VR/L	R AG4M L AGZT	X800 X400	3,95	2,95	1,95	18,0	0,58	0,8	R A04C.R L A04C.L inch
▼ ØD = 5,0 mm														
5,0	1,0	20,3	5,2	+	A05.0100.20.52 VR/L	R AHPY L AMKU	X800 X400	4,95	3,75	2,45	23,0	0,5	1,0	R A05.R L A05.L
5,0	1,168	20,3	5,2	+	A05.0117.20.52 VR/L	R AGGW L AFDM	X800 X400	4,95	3,75	2,45	23,0	0,58	1,0	R A05.R L A05.L inch
5,0	1,5	20,3	5,2	+	A05.0150.20.52 VR/L	R AA2S L ACC3	X800 X400	4,95	3,75	2,45	23,0	0,75	1,0	R A05.R L A05.L
5,0	1,575	20,3	5,2	+	A05.0157.20.52 VR/L	R AM8X L APCC	X800 X400	4,95	3,75	2,45	23,0	0,79	1,0	R A05.R L A05.L inch
5,0	1,626	20,3	5,2	+	A05.0163.20.52 VR/L	R AT8E L AT8D	X800 X400	4,95	3,75	2,45	23,0	0,81	1,0	R A05.R L A05.L inch
5,0	1,981	20,3	5,2	+	A05.0198.20.52 VR/L	R AT8G L AT8F	X800 X400	4,95	3,75	2,45	23,0	0,99	1,0	R A05.R L A05.L inch
5,0	2,0	20,3	5,2	+	A05.0200.20.52 VR/L	R AK1U L AMG6	X800 X400	4,95	3,75	2,45	23,0	1,0	1,0	R A05.R L A05.L
▼ ØD = 6,0 mm														
6,0	1,0	25,4	6,2	+	A06.0100.25.62 VR/L	R AKUZ L AFNY	X800 X400	5,95	3,95	2,95	28,0	0,5	1,8	R A06.R L A06.L
6,0	1,168	25,4	6,2	+	A06.0117.25.62 VR/L	R AKMZ L AGQY	X800 X400	5,95	3,95	2,95	28,0	0,58	1,8	R A06.R L A06.L inch
6,0	1,5	25,4	6,2	+	A06.0150.25.62 VR/L	R AD22 L AMMJ	X800 X400	5,95	3,95	2,95	28,0	0,75	1,8	R A06.R L A06.L
6,0	1,575	25,4	6,2	+	A06.0157.25.62 VR/L	R APSG L ANCZ	X800 X400	5,95	3,95	2,95	28,0	0,79	1,8	R A06.R L A06.L inch
6,0	1,626	25,4	6,2	+	A06.0163.25.62 VR/L	R AT8J L AT8H	X800 X400	5,95	3,95	2,95	28,0	0,81	1,8	R A06.R L A06.L inch
6,0	1,981	25,4	6,2	+	A06.0198.25.62 VR/L	R AT8M L AT8K	X800 X400	5,95	3,95	2,95	28,0	0,99	1,8	R A06.R L A06.L inch
6,0	2,0	20,3	6,2	+	A06.0200.20.62 VR/L	R AMVK L AFV9	X800 X400	5,95	3,95	2,95	23,0	1,0	1,8	R A06.R L A06.L
6,0	2,0	25,4	6,2	+	A06.0200.25.62 VR/L	R AH3S L AKZ8	X800 X400	5,95	3,95	2,95	28,0	1,0	1,8	R A06.R L A06.L

Verwandte Werkzeuge finden Sie auch auf der folgenden Seite!
Related Items can be found on the following page as well!

Fortgesetzte Tabelle
Continued Table

Bestellbeispiel // Order example: **A06.0200.25.62 VR X800** (R = Rechte Ausführung // Right hand version, X800 = Schneidstoff // Grade)

Stechen von Vollradiusnuten

Geeignet ab Bohrungsdurchmesser 4,2 mm.

Full Radius Grooving

For use in bores as of minimum bore diameter 4,2 mm.

Schnittwerte (Start) // Cutting parameters (start)	
f 0,02 mm/U	Vc Seite/Page 429

Passende Klemmhalter auf Seite // Suitable toolholders on page	
29, 31, 37, 42, 46, 52, 54, 56, 58, 61, 64, 65, 66, 67, 68, 69	

SP

HM

R

Legende
Legend

139

Scan
QR-Code

Oder besuchen Sie // Or Visit
www.simtek.info/cp/1391

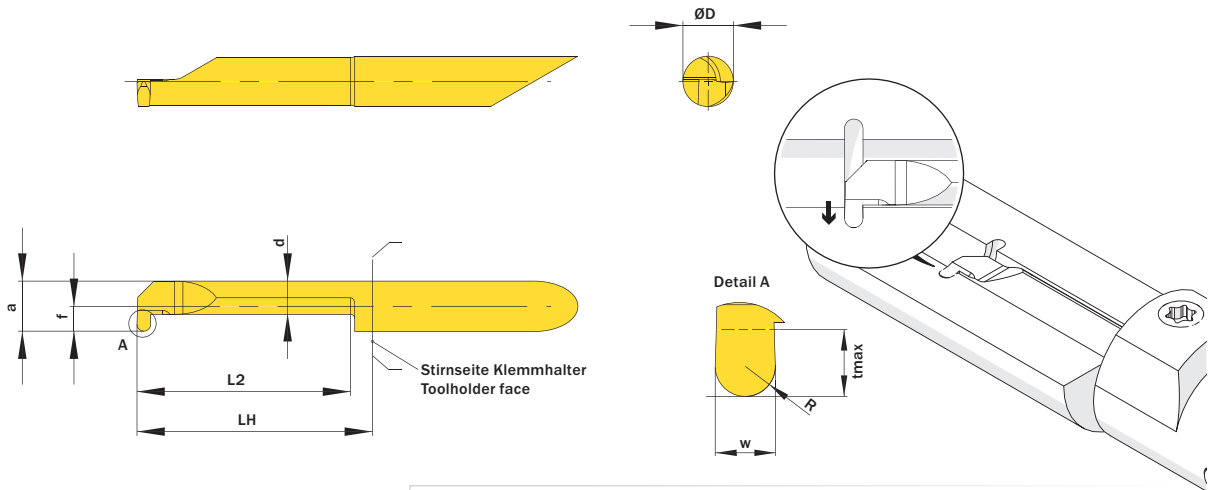


Abbildung zeigt / Drawing shows: A06.0150.25.62 VR

Mehr Informationen zur Kühlmittelzufuhr finden Sie auf Seite 22
Additional information about through coolant supply on page 22

ØD	w ^{+0,03}	L2	ØDmin (Min. Bohrung) ØDmin (min. bore)	Kühlmittelzufuhr Through coolant supply	Artikelnummer Part number	Webcode www.simtek.com/webcode	Unsere erste Wahl Our first choice	a	d	f	LH	R	tmax	Connectcode www.simtek.com/code
mm	mm	mm	mm				P K M N S	mm	mm	mm	mm	mm	mm	

Fortgesetzte Tabelle
Continued Table

Verwandte Werkzeuge finden Sie auch auf der vorhergehenden Seite!
Related items can be found on the previous page as well!

7,0	1,0	30,5	7,2	+	A07.0100.30.72 VR/L	R AMUA	L APBC	X800 X400	6,95	4,25	3,45	33,0	0,5	2,5	R	A07.R	L	A07.L	
7,0	1,168	30,5	7,2	+	A07.0117.30.72 VR/L	R ABU4	L AETJ	X800 X400	6,95	4,25	3,45	33,0	0,58	2,5	R	A07.R	L	A07.L	inch
7,0	1,5	30,5	7,2	+	A07.0150.30.72 VR/L	R AJX4	L AJG8	X800 X400	6,95	4,25	3,45	33,0	0,75	2,5	R	A07.R	L	A07.L	inch
7,0	1,575	30,5	7,2	+	A07.0157.30.72 VR/L	R AG9X	L AE47	X800 X400	6,95	4,25	3,45	33,0	0,79	2,5	R	A07.R	L	A07.L	inch
7,0	1,626	30,5	7,2	+	A07.0163.30.72 VR		A4N1	X800 X400	6,95	4,25	3,45	33,0	0,81	2,5		A07.R			new inch
7,0	1,981	30,5	7,2	+	A07.0198.30.72 VR/L	R AT8S	L AT8Q	X800 X400	6,95	4,25	3,45	33,0	0,99	2,5	R	A07.R	L	A07.L	inch
7,0	2,0	30,5	7,2	+	A07.0200.30.72 VR/L	R ACTT	L ACE9	X800 X400	6,95	4,25	3,45	33,0	1,0	2,5	R	A07.R	L	A07.L	

Bestellbeispiel // Order example: **A07.0100.30.72 VR X800** (R = Rechte Ausführung // Right hand version, X800 = Schneidstoff // Grade)

Vorstechen und Fasen

Geeignet ab Bohrungsdurchmesser 3,7 mm.

Pre-Part-Off and Chamfering

For use in bores as of minimum bore diameter 3,7 mm.

Schnittwerte (Start) // Cutting parameters (start)

f	Vc
0,02 mm/U	Seite/Page 429

Passende Klemmhalter auf Seite // Suitable toolholders on page

26, 27, 28, 31, 32, 33, 34, 35, 36,
 40, 41, 42, 43, 44, 45, 50, 51, 53,
 55, 56, 57, 58, 60, 61, 62, 63, 64,
 65, 66, 67, 68, 69



SP **HM** **R** **Legende** **139**
 Legend
 Oder besuchen Sie // Or Visit
www.simtek.info/cp/779

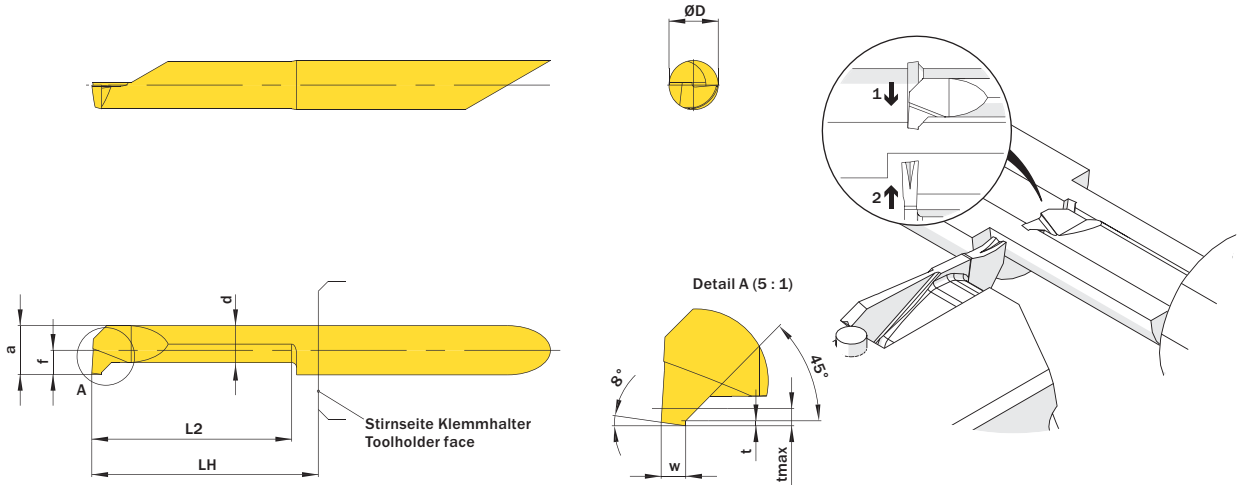


Abbildung zeigt / Drawing shows: A05.0100.20.52 PR

Mehr Informationen zur Kühlmittelzufuhr finden Sie auf Seite 22
 Additional information about through coolant supply on page 22

ØD	w	L2	ØDmin (Min. Bohrung) ØDmin (min. bore)	Kühlmittelzufuhr Through coolant supply	Artikelnummer Part number	Webcode www.simtek.com/webcode	Unsere erste Wahl Our first choice	a	d	f	LH	t	tmax	Connectcode www.simtek.com/code
mm	mm	mm	mm				P K M N S	mm	mm	mm	mm	mm	mm	
▼ ØDmin (Min. Bohrung) // ØDmin (min. bore) = 3,7 mm														
4,0	1,0	10,2	3,7	+	A04.0100.10.37 PR/L	R AEDE L AVEZ	X800 X400	3,45	2,45	1,7	13,0	0,2	0,7	R A04.R A04C.R L A04.L A04C.L
4,0	1,0	15,2	3,7	+	A04.0100.15.37 PR/L	R ACD1 L AVEØ	X800 X400	3,45	2,45	1,7	18,0	0,2	0,7	R A04.R A04C.R L A04.L A04C.L
▼ ØDmin (Min. Bohrung) // ØDmin (min. bore) = 4,2 mm														
4,0	1,0	20,3	4,2	+	A04.0100.20.42 PR/L	R AJ2W L AVE1	X800 X400	3,95	2,95	1,95	23,0	0,2	0,7	R A04C.R L A04C.L
▼ ØDmin (Min. Bohrung) // ØDmin (min. bore) = 5,2 mm														
5,0	1,0	15,2	5,2	+	A05.0100.15.52 PR/L	R AFZX L AD7M	X800 X400	4,95	3,75	2,45	18,0	0,2	0,7	R A05.R L A05.L
5,0	1,0	20,3	5,2	+	A05.0100.20.52 PR/L	R ADØE L ANDY	X800 X400	4,95	3,75	2,45	23,0	0,2	0,7	R A05.R L A05.L
5,0	1,0	25,4	5,2	+	A05.0100.25.52 PR/L	R AHXE L AHFW	X800 X400	4,95	3,75	2,45	28,0	0,2	0,7	R A05.R L A05.L
5,0	1,0	30,5	5,2	+	A05.0100.30.52 PR/L	R AG19 L AH2E	X800 X400	4,95	3,75	2,45	33,0	0,2	0,7	R A05.R L A05.L
▼ ØDmin (Min. Bohrung) // ØDmin (min. bore) = 6,2 mm														
6,0	1,0	30,5	6,2	+	A06.0100.30.62 PR/L	R AFNW L AU6N	X800 X400	5,95	3,95	2,95	33,0	0,2	0,7	R A06.R L A06.L
6,0	1,0	40,6	6,2	+	A06.0100.40.62 PR/L	R AB64 L AU6P	X800 X400	5,95	3,95	2,95	43,0	0,2	0,7	R A06.R L A06.L

Bestellbeispiel // Order example: **A06.0100.30.62 PR X800** (R = Rechte Ausführung // Right hand version, X800 = Schneidstoff // Grade)

Gewindedrehen, Metr. ISO, Innen, Teilprofil

Mehrbereichswerkzeuge für unterschiedliche Steigungen.

Threading, Metr. ISO, Internal, Partial Profile

Multi-purpose tools, usable for different pitches.

Schnittwerte (Start) // Cutting parameters (start)

f	Vc
0,02 mm/U	Seite/Page 429

Passende Klemmhalter auf Seite // Suitable toolholders on page

31, 32, 34, 40, 41, 43, 50, 51, 53, 55, 56, 57, 60, 62, 63, 66, 67, 68, 69
--

Empf. Zustellungsart // Recom. infeed method
Flankenzustellung // Flank infeed (Seite/Page 433)

Bitte Hinweise im Anhang beachten // Please read add. notes
T01 (Seite/Page 137)



SP **HM** **R** Legende Legend **139**

Scan QR-Code Oder besuchen Sie // Or Visit www.simtek.info/cp/767

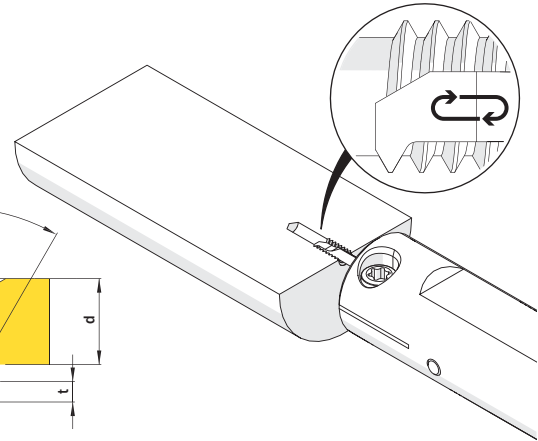
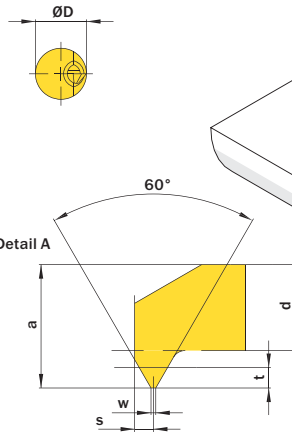
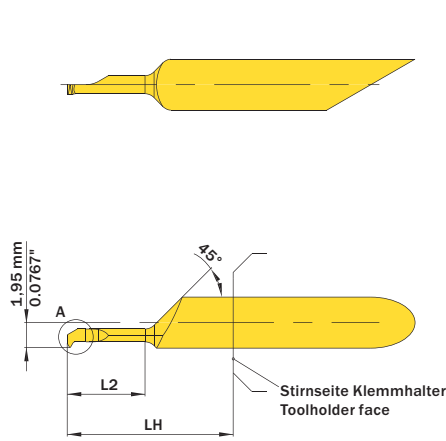
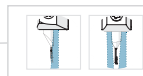


Abbildung zeigt / Drawing shows: A04.M045.01.06.17 M R



Mehr Informationen zur Kühlmittelzufuhr finden Sie auf Seite 22
Additional information about through coolant supply on page 22

ØD	Steigung (von Pitch (as of)	L2	ØDmin (Min. Bohrung) ØDmin (min. bore)	Kühlmittelzufuhr Through coolant supply	Artikelnummer Part number	Webcode www.simtek.com/webcode	Unsere erste Wahl Our first choice	Regelgewinde Standard pitch thread	a	d	LH	S	t	w	Connectcode www.simtek.com/code
mm	mm	mm	mm				P K M N S		mm	mm	mm	mm	mm	mm	
▼ Regelgewinde // Standard pitch thread = M1															
4,0	0,25	2,5	0,73	+	A04.M025.01.02.07 MR/L	R ABK0 L AD4Z	X800 X400	M1	0,67	0,39	13,0	0,14	0,14	0,03	R A04C.R L A04C.L
▼ Regelgewinde // Standard pitch thread = M1,6															
4,0	0,35	4,1	1,22	+	A04.M035.01.04.12 MR/L	R AKSA L AE2B	X800 X400	M1,6	1,1	0,71	13,0	0,18	0,19	0,04	R A04C.R L A04C.L
▼ Regelgewinde // Standard pitch thread = M2															
4,0	0,4	5,1	1,57	+	A04.M040.01.05.15 MR/L	R AB5T L AG6C	X800 X400	M2	1,4	0,98	13,0	0,2	0,22	0,05	R A04C.R L A04C.L
▼ Regelgewinde // Standard pitch thread = M2,2															
4,0	0,45	6,1	1,71	+	A04.M045.01.06.17 MR/L	R AH5G L ACVW	X800 X400	M2,2	1,45	1,01	13,0	0,22	0,24	0,06	R A04C.R L A04C.L
▼ Regelgewinde // Standard pitch thread = M3															
4,0	0,5	7,6	2,46	+	A04.M050.01.07.24 MR/L	R ADAU L ABCW	X800 X400	M3	2,2	1,73	13,0	0,24	0,27	0,06	R A04C.R L A04C.L
▼ Regelgewinde // Standard pitch thread = M4															
4,0	0,7	10,2	3,24	+	A04.M070.01.10.32 MR/L	R ABVG L AAKY	X800 X400	M4	2,95	2,37	13,0	0,32	0,38	0,09	R A04C.R L A04C.L
4,0	0,7	15,2	3,24	+	A04.M070.01.15.32 MR/L	R A05G L A05H	X800 X400	M4	2,95	2,37	18,0	0,32	0,38	0,09	R A04C.R L A04C.L

Bestellbeispiel // Order example: **A04.M035.01.04.12 MR X800** (R = Rechte Ausführung // Right hand version, X800 = Schneidstoff // Grade)

Bitte beachten Sie die zusätzlichen Hinweise im Infobereich rechts oben.

Please read the additional notes mentioned in the information area on the top right corner of this page.

simturn AX
simturn DX
simturn PX
simturn H2
simturn K2
simturn C4
simturn GX
simturn E3
simturn E12
simturn FX
simturn Decolletage
simturn OA
Index

Gewindedrehen, Metr. ISO, Innen, Teilprofil

Mehrbereichswerkzeuge für unterschiedliche Steigungen.

Threading, Metr. ISO, Internal, Partial Profile

Multi-purpose tools, usable for different pitches.

Schnittwerte (Start) // Cutting parameters (start)
Anzahl Durchgänge // Number of passes 10 - 16
Empf. Zustellungsart // Recom. infeed method Flankenzustellung // Flank infeed (Seite/Page 433)
Vc Seite/Page 429
Passende Klemmhalter auf Seite // Suitable toolholders on page 27, 28, 31, 32, 33, 34, 35, 36, 40, 41, 42, 43, 44, 45, 50, 51, 53, 55, 56, 57, 58, 60, 61, 62, 63, 64, 65, 66, 67, 68, 69
Bitte Hinweise im Anhang beachten // Please read add. notes T01 (Seite/Page 137)

SP

HM

R

Legende
Legend **139**

Scan QR-Code

Oder besuchen Sie // Or Visit
www.simtek.info/cp/770

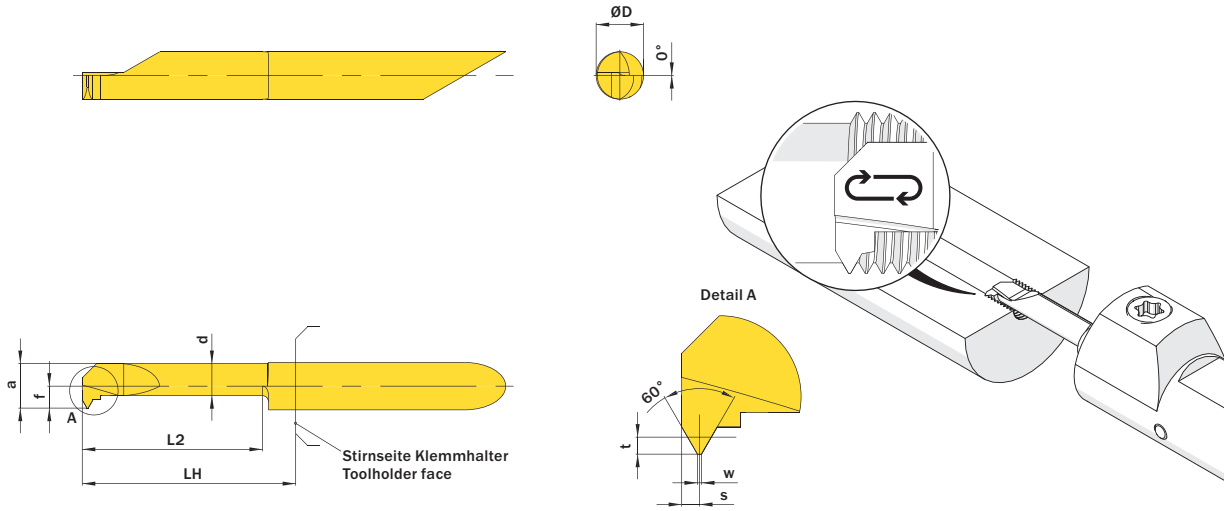


Abbildung zeigt / Drawing shows: A04.MT08.01.15.39 M R

Mehr Informationen zur Kühlmittelzufuhr finden Sie auf Seite 22
 Additional information about through coolant supply on page 22

ØD	Steigung (von) Pitch (as of)	Steigung (bis) Pitch (up to)	L2	ØDmin (Min. Bohrung) ØDmin (min. bore)	Kühlmittelzufuhr Through coolant supply	Artikelnummer Part number	Webcode www.simtek.com/webcode	Unsere erste Wahl Our first choice	a	d	f	LH	S	t	w	Connectcode www.simtek.com/code
mm	mm	mm	mm	mm				P K M N S	mm	mm	mm	mm	mm	mm	mm	
▼ ØDmin (Min. Bohrung) // ØDmin (min. bore) = 3,9 mm																
4,0	0,8	1,0	15,2	3,9	+	A04.MT08.01.15.39 MR/L	R AW95 L AXA0	X800 X400	3,65	2,7	1,95	18,0	0,45	0,46	0,1	R A04C.R L A04C.L
▼ ØDmin (Min. Bohrung) // ØDmin (min. bore) = 4,2 mm																
4,0	0,5	0,7	15,2	4,2	+	A04.MT05.01.15.42 MR/L	R AD6S L AHZD	X800 X400	3,95	2,95	1,95	18,0	0,35	0,4	0,06	R A04C.R L A04C.L
▼ ØDmin (Min. Bohrung) // ØDmin (min. bore) = 4,8 mm																
5,0	1,0	1,25	15,2	4,8	+	A05.MT10.01.15.48 MR/L	R AJA0 L ABPY	X800 X400	4,55	3,55	2,25	18,0	0,55	0,7	0,12	R A05.R L A05.L
5,0	1,0	1,25	20,3	4,8	+	A05.MT10.01.20.48 MR/L	R AC5K L AK4K	X800 X400	4,55	3,55	2,25	23,0	0,55	0,7	0,12	R A05.R L A05.L
5,0	1,0	1,25	25,4	4,8	+	A05.MT10.01.25.48 MR/L	R AH4D L AHJU	X800 X400	4,55	3,55	2,25	28,0	0,55	0,7	0,12	R A05.R L A05.L
▼ ØDmin (Min. Bohrung) // ØDmin (min. bore) = 5,1 mm																
5,0	0,75	1,0	15,2	5,1	+	A05.MT07.01.15.51 MR/L	R APGS L ADYW	X800 X400	4,85	3,65	2,4	18,0	0,45	0,57	0,09	R A05.R L A05.L
▼ ØDmin (Min. Bohrung) // ØDmin (min. bore) = 5,2 mm																
5,0	0,5	0,75	15,2	5,2	+	A05.MT05.01.15.52 MR/L	R AE44 L APTP	X800 X400	4,95	3,75	2,45	18,0	0,35	0,43	0,06	R A05.R L A05.L
▼ ØDmin (Min. Bohrung) // ØDmin (min. bore) = 6,2 mm																
6,0	1,0	1,25	15,2	6,2	+	A06.MT10.01.15.62 MR/L	R AAT9 L APQ7	X800 X400	5,95	3,95	2,95	18,0	0,55	0,7	0,12	R A06.R L A06.L
6,0	1,25	1,5	15,2	6,2	+	A06.MT12.01.15.62 MR/L	R AG92 L APSQ	X800 X400	5,95	3,95	2,95	18,0	0,75	0,84	0,16	R A06.R L A06.L
6,0	1,25	1,5	20,3	6,2	+	A06.MT12.01.20.62 MR/L	R ABDJ L AFV2	X800 X400	5,95	3,95	2,95	23,0	0,75	0,84	0,16	R A06.R L A06.L
6,0	1,25	1,5	25,4	6,2	+	A06.MT12.01.25.62 MR/L	R ABY1 L AJGW	X800 X400	5,95	3,95	2,95	28,0	0,75	0,84	0,16	R A06.R L A06.L
6,0	1,5	1,75	15,2	6,2	+	A06.MT15.01.15.62 MR/L	R AHZW L AKQS	X800 X400	5,95	3,95	2,95	18,0	0,8	0,98	0,18	R A06.R L A06.L
6,0	1,5	1,75	20,3	6,2	+	A06.MT15.01.20.62 MR/L	R AAT5 L AECJ	X800 X400	5,95	3,95	2,95	23,0	0,8	0,98	0,18	R A06.R L A06.L
6,0	1,5	1,75	25,4	6,2	+	A06.MT15.01.25.62 MR/L	R AACA L AB3N	X800 X400	5,95	3,95	2,95	28,0	0,8	0,98	0,18	R A06.R L A06.L

Bestellbeispiel // Order example: **A06.MT15.01.15.62 MR X800** (R = Rechte Ausführung // Right hand version, X800 = Schneidstoff // Grade)

Bitte beachten Sie die zusätzlichen Hinweise im Infobereich rechts oben.
 Please read the additional notes mentioned in the information area on the top right corner of this page.

Gewindedrehen, Metr. ISO, Innen, Vollprofil

Herstellung des vollständigen Gewindeprofils mit notwendiger Tiefe.

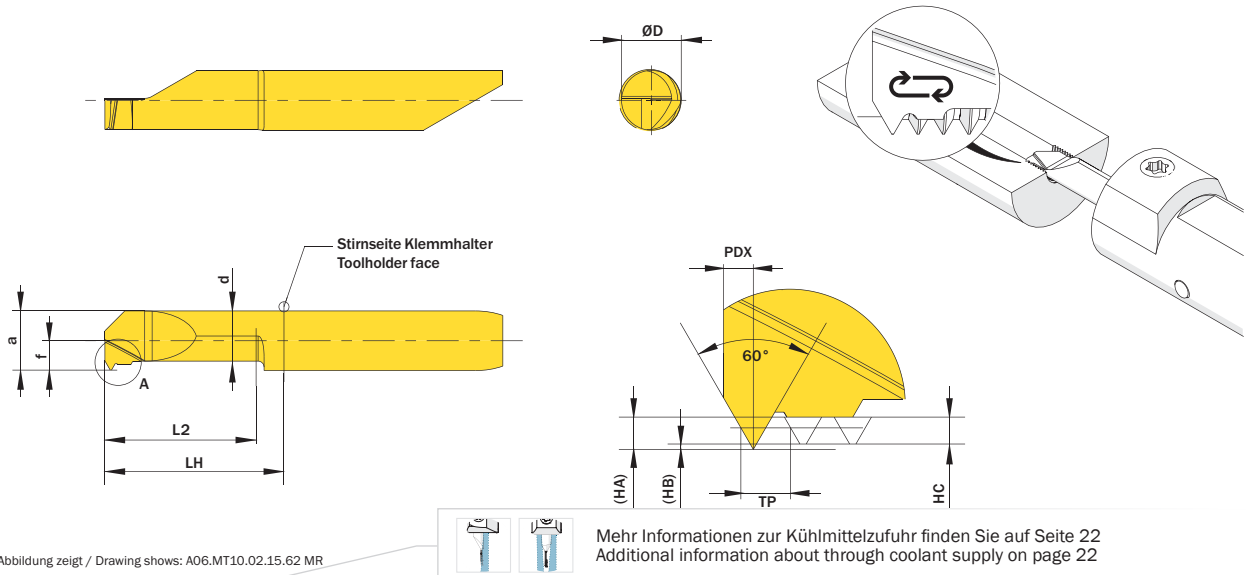
Threading, Metr. ISO, Internal, Full Profile

For a complete thread profile with correct depth.

Schnittwerte (Start) // Cutting parameters (start)
Anzahl Durchgänge // Number of passes 10 - 16
Empf. Zustellungsart // Recom. infeed method Flankenzustellung // Flank infeed (Seite/Page 433)
Vc Seite/Page 429
Passende Klemmhalter auf Seite // Suitable toolholders on page 27, 28, 31, 32, 33, 34, 35, 36, 40, 41, 42, 43, 44, 45, 50, 51, 53, 55, 56, 57, 58, 60, 61, 62, 63, 64, 65, 66, 67, 68, 69

SP **HM** **R** Legende Legend **139**

Scan QR-Code Oder besuchen Sie // Or Visit www.simtek.info/cp/771



ØD	Steigung TP Pitch TP	L2	ØDmin (Min. Bohrung) ØDmin (min. bore)	Kühlmittelzufuhr Through coolant supply	Artikelnummer Part number	Webcode www.simtek.com/webcode	Unsere erste Wahl Our first choice	a	d	f	HC	HA	HB	LH	PDX	S	Connectcode www.simtek.com/code	
mm	mm	mm	mm				P K M N S	mm	mm	mm	mm	mm	mm	mm	mm	mm		
▼ ØDmin (Min. Bohrung) // ØDmin (min. bore) = 3,2 mm																		
4,0	0,7	15,2	3,2	+	A04.MT07.02.15.32 MR/L	R AX2A L AX2B	X800 X400	2,95	2,35	1,95	0,379	0,455	0,076	18,0	0,45	0,45	R	A04C.R L A04C.L upd
▼ ØDmin (Min. Bohrung) // ØDmin (min. bore) = 3,9 mm																		
4,0	0,8	15,2	3,9	+	A04.MT08.02.15.39 MR/L	R AW96 L AXA1	X800 X400	3,65	2,9	1,95	0,433	0,52	0,087	18,0	0,5	0,5	R	A04C.R L A04C.L upd
▼ ØDmin (Min. Bohrung) // ØDmin (min. bore) = 4,2 mm																		
4,0	0,5	15,2	4,2	+	A04.MT05.02.15.42 MR/L	R AM3S L APPS	X800 X400	3,95	3,45	1,95	0,271	0,325	0,054	18,0	0,4	0,4	R	A04C.R L A04C.L upd
4,0	0,7	15,2	4,2	+	A04.MT07.02.15.42 MR/L	R AX5W L AX5V	X800 X400	3,95	3,35	1,95	0,379	0,455	0,076	18,0	0,45	0,45	R	A04C.R L A04C.L upd
▼ ØDmin (Min. Bohrung) // ØDmin (min. bore) = 4,8 mm																		
5,0	1,0	15,2	4,8	+	A05.MT10.02.15.48 MR/L	R AANF L ANT3	X800 X400	4,55	3,55	2,25	0,541	0,65	0,108	18,0	0,6	0,6	R	A05.R L A05.L upd
▼ ØDmin (Min. Bohrung) // ØDmin (min. bore) = 5,1 mm																		
5,0	0,75	15,2	5,1	+	A05.MT75.02.15.51 MR/L	R AAP5 L ABV5	X800 X400	4,85	4,15	2,4	0,406	0,487	0,081	18,0	0,5	0,5	R	A05.R L A05.L upd
▼ ØDmin (Min. Bohrung) // ØDmin (min. bore) = 5,2 mm																		
5,0	0,5	15,2	5,2	+	A05.MT05.02.15.52 MR/L	R AGN4 L ABNU	X800 X400	4,95	4,45	2,45	0,271	0,325	0,054	18,0	0,4	0,4	R	A05.R L A05.L upd
▼ ØDmin (Min. Bohrung) // ØDmin (min. bore) = 6,2 mm																		
6,0	1,0	15,2	6,2	+	A06.MT10.02.15.62 MR/L	R ANZG L APA6	X800 X400	5,95	5,05	2,95	0,541	0,65	0,108	18,0	0,6	0,6	R	A06.R L A06.L upd
6,0	1,0	25,4	6,2	+	A06.MT10.02.25.62 MR	AYXW	X800 X400	5,95	5,05	2,95	0,541	0,65	0,108	28,0	0,6	0,6		A06.R upd
6,0	1,25	15,2	6,2	+	A06.MT12.02.15.62 MR/L	R ANSN L AB2Z	X800 X400	5,95	4,8	2,95	0,677	0,812	0,135	18,0	0,7	0,7	R	A06.R L A06.L upd
6,0	1,25	25,4	6,2	+	A06.MT12.02.25.62 MR	AYXX	X800 X400	5,95	4,8	2,95	0,677	0,812	0,135	28,0	0,7	0,7		A06.R upd
6,0	1,5	15,2	6,2	+	A06.MT15.02.15.62 MR/L	R ADMY L ADBX	X800 X400	5,95	4,5	2,95	0,812	0,974	0,162	18,0	0,8	0,8	R	A06.R L A06.L upd
6,0	1,5	25,4	6,2	+	A06.MT15.02.25.62 MR	AYXY	X800 X400	5,95	4,5	2,95	0,812	0,974	0,162	28,0	0,8	0,8		A06.R upd
6,0	1,75	15,2	6,2	+	A06.MT17.02.15.62 MR/L	R APC1 L AKJ7	X800 X400	5,95	4,3	2,95	0,947	1,137	0,189	18,0	0,9	0,9	R	A06.R L A06.L upd
6,0	1,75	25,4	6,2	+	A06.MT17.02.25.62 MR	AYXZ	X800 X400	5,95	4,3	2,95	0,947	1,137	0,189	28,0	0,9	0,9		A06.R upd
6,0	2,0	15,2	6,2	+	A06.MT20.02.15.62 MR/L	R AK5N L AN51	X800 X400	5,95	4,1	2,95	1,083	1,299	0,217	18,0	1,0	1,0	R	A06.R L A06.L upd
6,0	2,0	25,4	6,2	+	A06.MT20.02.25.62 MR	AYX0	X800 X400	5,95	4,1	2,95	1,083	1,299	0,217	28,0	1,0	1,0		A06.R upd

Bestellbeispiel // Order example: **A06.MT10.02.15.62 MR X800** (R = Rechte Ausführung // Right hand version, X800 = Schneidstoff // Grade)

simturn AX
simturn DX
simturn PX
simturn H2
simturn K2
simturn C4
simturn GX
simturn E3
simturn E12
simturn FX
simturn Decolletage
simturn OA
Index

Gewindedrehen, Trapezgew., Innen, Teilprofil

Teilprofil für Innen-Trapezgewinde.

Threading, Trapezoidal, Internal, Partial Profile

Partial profile for internal trapezoidal thread.

Schnittwerte (Start) // Cutting parameters (start)
Anzahl Durchgänge // Number of passes 12 - 18
Empf. Zustellungsart // Recom. infeed method Flankenzustellung // Flank infeed (Seite/Page 433)
Vc Seite/Page 429

Passende Klemmhalter auf Seite // Suitable toolholders on page
28, 29, 31, 36, 37, 42, 45, 46, 50, 51, 52, 53, 54, 55, 56, 58, 61, 62, 64, 65, 66, 67, 68, 69



SP **HM** **R** Legende Legend **139**

Scan QR-Code Oder besuchen Sie // Or Visit www.simtek.info/cp/773

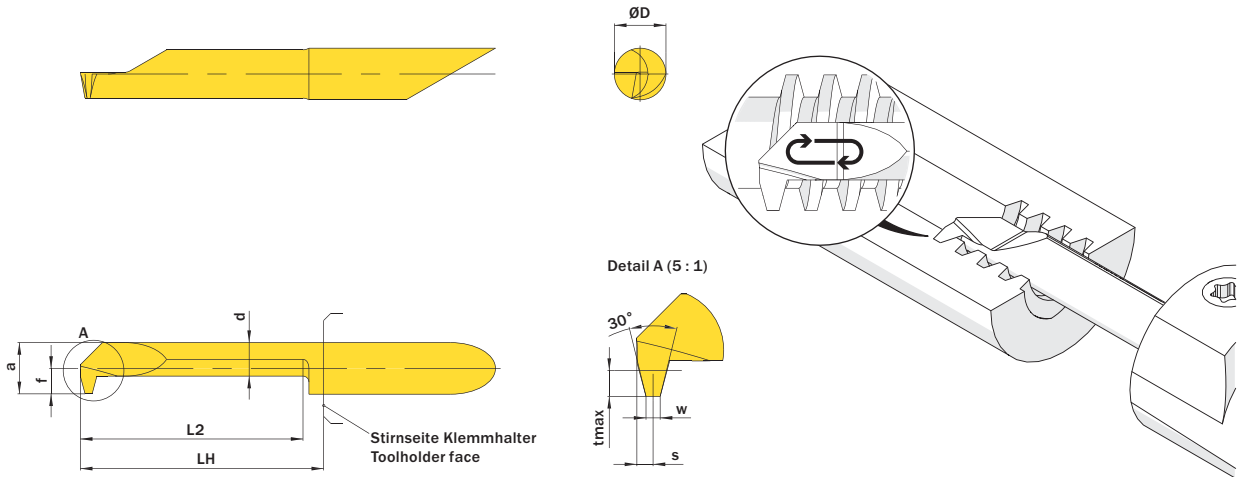


Abbildung zeigt / Drawing shows: A07.TR30.01.30.72 M R

Mehr Informationen zur Kühlmittelzufuhr finden Sie auf Seite 22
Additional information about through coolant supply on page 22

ØD	Steigung (von Pitch (as of)	L2	ØDmin (Min. Bohrung) // ØDmin (min. bore)	Kühlmittelzufuhr // Through coolant supply	Artikelnummer // Part number	Webcode www.simtek.com/webcode	Unsere erste Wahl // Our first choice	a	d	f	LH	S	tmax	w	Connectcode www.simtek.com/ccode	
mm	mm	mm	mm				P K M N S	mm	mm	mm	mm	mm	mm	mm		
▼ ØDmin (Min. Bohrung) // ØDmin (min. bore) = 6,2 mm																
6,0	1,5	20,3	6,2	+	A06.TR15.01.20.62 MR/L	R AF38 L ABDP	X800 X400	5,95	4,9	2,95	23,0	0,6	0,9	0,47	R	A06.R L A06.L
6,0	2,0	20,3	6,2	+	A06.TR20.01.20.62 MR/L	R AAZ9 L AMPG	X800 X400	5,95	4,55	2,95	23,0	0,75	1,25	0,6	R	A06.R L A06.L
▼ ØDmin (Min. Bohrung) // ØDmin (min. bore) = 7,2 mm																
7,0	2,0	20,3	7,2	+	A07.TR20.01.20.72 MR/L	R AHAK L AK4J	X800 X400	6,95	5,05	3,45	23,0	0,75	1,25	0,59	R	A07.R L A07.L
7,0	2,0	30,5	7,2	+	A07.TR20.01.30.72 MR/L	R AGM5 L AEG5	X800 X400	6,95	5,05	3,45	33,0	0,75	1,25	0,59	R	A07.R L A07.L
7,0	3,0	20,3	7,2	+	A07.TR30.01.20.72 MR/L	R AKCZ L AJGN	X800 X400	6,95	4,55	3,45	23,0	1,1	1,75	0,96	R	A07.R L A07.L
7,0	3,0	30,5	7,2	+	A07.TR30.01.30.72 MR/L	R APWE L AKJD	X800 X400	6,95	4,55	3,45	33,0	1,1	1,75	0,96	R	A07.R L A07.L

Bestellbeispiel // Order example: **A07.TR30.01.30.72 MR X800** (R = Rechte Ausführung // Right hand version, X800 = Schneidstoff // Grade)

Gewindedrehen, NPT, Innen, Teilprofil

Teilprofil für Innen-NPT-Gewinde.

Threading, NPT, Internal, Partial Profile

Partial profile for internal NPT thread.

Schnittwerte (Start) // Cutting parameters (start)
Anzahl Durchgänge // Number of passes 10 - 16
Empf. Zustellungsart // Recom. infeed method Flankenzustellung // Flank infeed (Seite/Page 433)
Vc Seite/Page 429

Passende Klemmhalter auf Seite // Suitable toolholders on page
28, 31, 36, 42, 45, 50, 51, 53, 55, 56, 58, 61, 62, 64, 65, 66, 67, 68, 69

SP

HM

R

Legende
Legend **139**

Scan
QR-Code

Oder besuchen Sie // Or Visit
www.simtek.info/cp/772

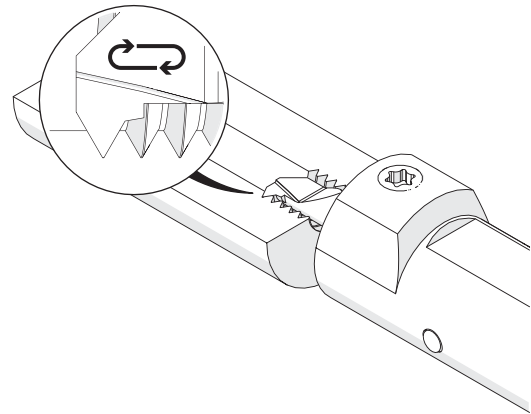
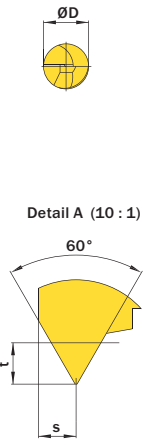
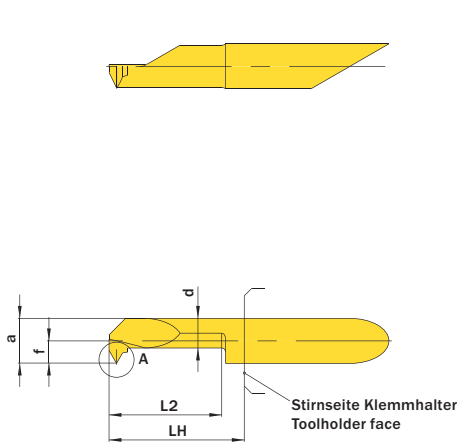


Abbildung zeigt / Drawing shows: A06.NP18.01.15.62 M R

Mehr Informationen zur Kühlmittelzufuhr finden Sie auf Seite 22
Additional information about through coolant supply on page 22

ØD	Gang/Zoll Threads/Inch	L2	ØDmin (Min. Bohrung) ØDmin (min. bore)	Kühlmittelzufuhr Through coolant supply	Artikelnummer Part number	Webcode www.simtek.com/webcode	Unsere erste Wahl Our first choice	a	d	f	LH	S	t	Connectcode www.simtek.com/code
mm		mm	mm				P K M N S	mm	mm	mm	mm	mm	mm	
▼ Gang/Zoll // Threads/Inch = 18														
6,0	18	15,2	6,2	+	A06.NP18.01.15.62 MR/L	R AC4A L AMGC	X800 X400	5,95	3,95	2,95	18,0	1,0	1,35	R A06.R L A06.L
▼ Gang/Zoll // Threads/Inch = 27														
6,0	27	15,2	6,2	+	A06.NP27.01.15.62 MR/L	R APHY L AM4Y	X800 X400	5,95	3,95	2,95	18,0	0,8	1,0	R A06.R L A06.L

Bestellbeispiel // Order example: **A06.NP18.01.15.62 MR X800** (R = Rechte Ausführung // Right hand version, X800 = Schneidstoff // Grade)

simturn AX
simturn DX
simturn PX
simturn H2
simturn K2
simturn C4
simturn GX
simturn E3
simturn E12
simturn FX
simturn Decolettage
simturn OA
Index

Gewindedrehen, UN, Innen, Teilprofil

Teilprofil für Innen-UN-Gewinde.

Threading, UN, Internal, Partial Profile

Partial profile for internal UN thread.

Schnittwerte (Start) // Cutting parameters (start)
Anzahl Durchgänge // Number of passes 10 - 16
Empf. Zustellungsart // Recom. infeed method Flankenzustellung // Flank infeed (Seite/Page 433)
Vc Seite/Page 429
Passende Klemmhalter auf Seite // Suitable toolholders on page 27, 28, 31, 32, 33, 34, 35, 36, 40, 41, 42, 43, 44, 45, 50, 51, 53, 55, 56, 57, 58, 60, 61, 62, 63, 64, 65, 66, 67, 68, 69

SP

HM

R

Legende
 Legend

139

Oder besuchen Sie // Or Visit
www.simtek.info/cp/774

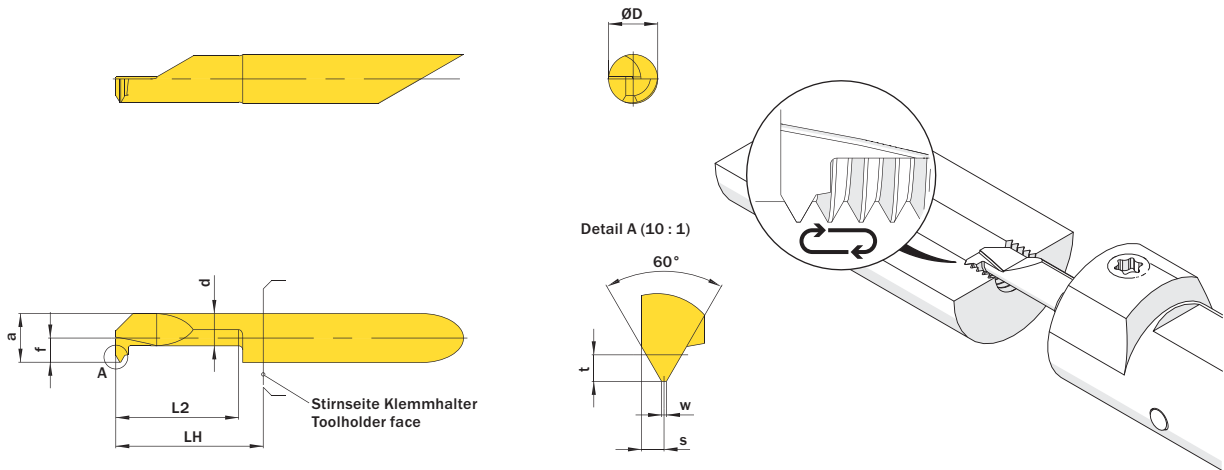


Abbildung zeigt / Drawing shows: A06.UN24.01.15.62 M R

Mehr Informationen zur Kühlmittelzufuhr finden Sie auf Seite 22
 Additional information about through coolant supply on page 22

ØD	Gang/Zoll Threads/Inch	L2	ØDmin (Min. Bohrung) ØDmin (min. bore)	Kühlmittelzufuhr Through coolant supply	Artikelnummer Part number	Webcode www.simtek.com/webcode	Unsere erste Wahl Our first choice	a	d	f	LH	S	t	w	Connectcode www.simtek.com/code
mm		mm	mm				P K M N S	mm	mm	mm	mm	mm	mm	mm	
▼ ØDmin (Min. Bohrung) // ØDmin (min. bore) = 4,2 mm															
4,0	32-40	15,2	4,2	+	A04.UN32.01.15.42 MR/L	R AF1W L AASQ	X800 X400	3,95	2,95	1,95	18,0	0,45	0,49	0,08	R A04C.R L A04C.L
▼ ØDmin (Min. Bohrung) // ØDmin (min. bore) = 5,2 mm															
5,0	24-28	15,2	5,2	+	A05.UN24.01.15.52 MR/L	R APZB L ANS8	X800 X400	4,95	3,75	2,45	18,0	0,55	0,64	0,11	R A05.R L A05.L
5,0	32-40	15,2	5,2	+	A05.UN32.01.15.52 MR/L	R AEH2 L ANNA	X800 X400	4,95	3,75	2,45	18,0	0,45	0,49	0,08	R A05.R L A05.L
▼ ØDmin (Min. Bohrung) // ØDmin (min. bore) = 6,2 mm															
6,0	16-20	15,2	6,2	+	A06.UN16.01.15.62 MR/L	R AA4A L ADKY	X800 X400	5,95	3,95	2,95	18,0	0,9	0,97	0,16	R A06.R L A06.L
6,0	24-28	15,2	6,2	+	A06.UN24.01.15.62 MR/L	R ACDX L ADTJ	X800 X400	5,95	3,95	2,95	18,0	0,55	0,64	0,11	R A06.R L A06.L

Bestellbeispiel // Order example: **A06.UN24.01.15.62 MR X800** (R = Rechte Ausführung // Right hand version, X800 = Schneidstoff // Grade)

Gewindedrehen, UNC/UNF, Innen, Vollprofil

Herstellung des vollständigen Gewindeprofils mit notwendiger Tiefe.

Threading, UNC/UNF, Internal, Full Profile

For a complete thread profile with correct depth.

Schnittwerte (Start) // Cutting parameters (start)

Anzahl Durchgänge // Number of passes
10 - 16

Empf. Zustellungsart // Recom. infeed method
Flankenzustellung // Flank infeed (Seite/Page 433)

Vc
Seite/Page 429

Passende Klemmhalter auf Seite // Suitable toolholders on page

27, 28, 31, 32, 33, 34, 35, 36, 40, 41, 42, 43, 44, 45, 50, 51, 53, 55, 56, 57, 58, 60, 61, 62, 63, 64, 65, 66, 67, 68, 69



SP HM R Legende Legend **139**
Scan QR-Code Oder besuchen Sie // Or Visit www.simtek.info/cp/775

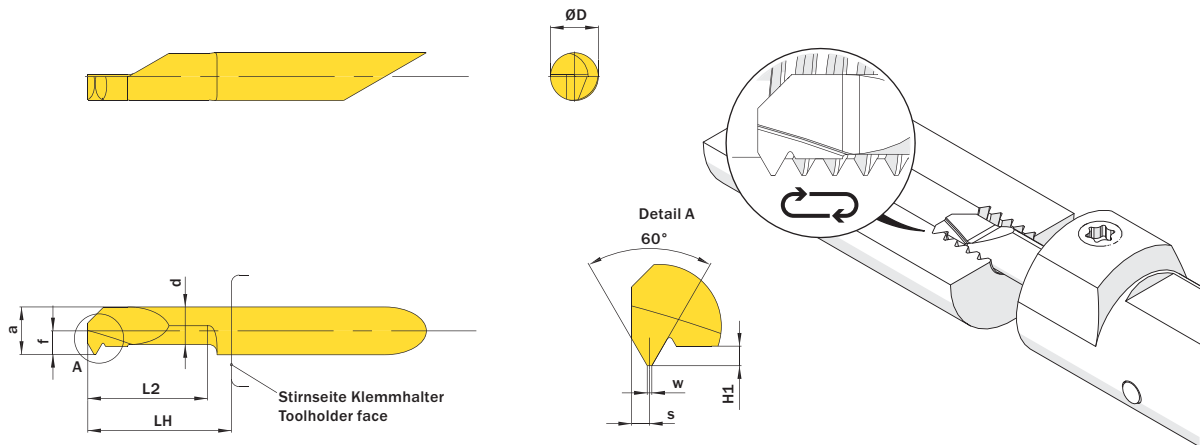
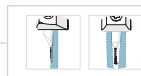


Abbildung zeigt / Drawing shows: A04.UN14.02.15.62 M R



Mehr Informationen zur Kühlmittelzufuhr finden Sie auf Seite 22
Additional information about through coolant supply on page 22

ØD	Gang/Zoll Threads/Inch	L2	Kühlmittelzufuhr Through coolant supply	Artikelnummer Part number	Webcode www.simtek.com/webcode	Unsere erste Wahl Our first choice	a	d	ØDmin (Min. Bohrung) ØDmin (min. bore)	f	H1	LH	Steigung (von) Pitch (as of)	S	w	Connectcode www.simtek.com/code
▼ ØDmin (Min. Bohrung) // ØDmin (min. bore) = 3,9 mm																
4,0	28	15,2	+	A04.UN28.02.15.39 MR/L	R AW98 L AD3Q	X800 X400	3,75	2,95	3,9	1,85	0,49	18,0	0,91	0,6	0,11	R A04C.R L A04C.L
4,0	32	15,2	+	A04.UN32.02.15.39 MR/L	R AW97 L AXA2	X800 X400	3,75	2,95	3,9	1,85	0,43	18,0	0,79	0,55	0,1	R A04C.R L A04C.L
▼ ØDmin (Min. Bohrung) // ØDmin (min. bore) = 4,2 mm																
4,0	24	15,2	+	A04.UN24.02.15.42 MR/L	R ACKF L AAPQ	X800 X400	3,95	3,05	4,2	1,95	0,57	18,0	1,06	0,65	0,13	R A04C.R L A04C.L
▼ ØDmin (Min. Bohrung) // ØDmin (min. bore) = 5,2 mm																
5,0	20	15,2	+	A05.UN20.02.15.52 MR/L	R AJXH L ATV1	X800 X400	4,95	3,95	5,2	2,45	0,69	18,0	1,27	0,7	0,16	R A05.R L A05.L
▼ ØDmin (Min. Bohrung) // ØDmin (min. bore) = 6,2 mm																
6,0	14	15,2	+	A06.UN14.02.15.62 MR/L	R AGVT L AEVU	X800 X400	5,95	4,55	6,2	2,95	0,98	18,0	1,81	0,9	0,23	R A06.R L A06.L
6,0	16	15,2	+	A06.UN16.02.15.62 MR/L	R AMTC L AGN9	X800 X400	5,95	4,75	6,2	2,95	0,86	18,0	1,59	0,85	0,2	R A06.R L A06.L
6,0	18	15,2	+	A06.UN18.02.15.62 MR/L	R AK2J L AFD2	X800 X400	5,95	4,85	6,2	2,95	0,76	18,0	1,41	0,75	0,18	R A06.R L A06.L

Bestellbeispiel // Order example: **A05.UN20.02.15.52 MR X800** (R = Rechte Ausführung // Right hand version, X800 = Schneidstoff // Grade)

simturn AX
simturn DX
simturn PX
simturn H2
simturn K2
simturn C4
simturn GX
simturn E3
simturn E12
simturn FX
simturn Decollette
simturn OA
Index

Gewindedrehen, Whitworth, Innen, Vollprofil

Herstellung des vollständigen Gewindeprofils mit notwendiger Tiefe sowie Kopf- und Fußradien.

Threading, Whitworth, Internal, Full Profile

For a complete thread profile with correct depth, top radius and bottom radius.

Schnittwerte (Start) // Cutting parameters (start)

Anzahl Durchgänge // Number of passes
10 - 16

Empf. Zustellungsart // Recom. infeed method
Flankenzustellung // Flank infeed (Seite/Page 433)

Vc
Seite/Page 429

Passende Klemmhalter auf Seite // Suitable toolholders on page
27, 28, 31, 33, 35, 36, 41, 42, 44, 45, 50, 51, 53, 55, 56, 57, 58, 61, 62, 63, 64, 65, 66, 67, 68, 69



Legende
Legend **139**

Scan QR-Code Oder besuchen Sie // Or Visit
www.simtek.info/cp/769

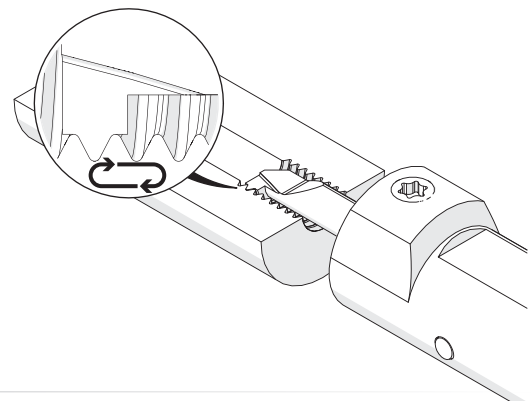
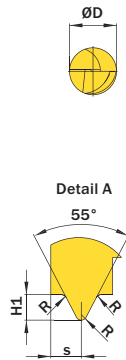
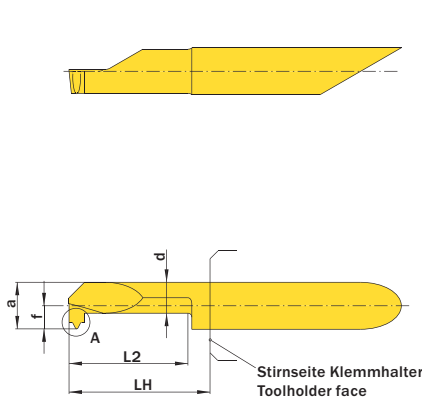
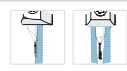


Abbildung zeigt / Drawing shows: A06.BS20.02.15.62 MR



Mehr Informationen zur Kühlmittelzufuhr finden Sie auf Seite 22
Additional information about through coolant supply on page 22

ØD	Gang/Zoll Threads/Inch	L2	ØDmin (Min. Bohrung) ØDmin (min. bore)	Kühlmittelzufuhr Through coolant supply	Artikelnummer Part number	Webcode www.simtek.com/webcode	Unsere erste Wahl Our first choice	a	d	f	H1	LH	Steigung (von) Pitch (as of)	R	S	Connectcode www.simtek.com/code	
mm		mm	mm				P K M N S	mm	mm	mm	mm	mm	mm	mm	mm		
▼ ØDmin (Min. Bohrung) // ØDmin (min. bore) = 5,2 mm																	
5,0	24	15,2	5,2	+	A05.BS24.02.15.52 MR/L	R AJKA L APDA	X800 X400	4,95	3,75	2,45	0,677	18,0	1,058	0,145	0,8	R	A05.R L A05.L
5,0	26	15,2	5,2	+	A05.BS26.02.15.52 MR/L	R AF70 L AFBU	X800 X400	4,95	3,75	2,45	0,625	18,0	0,977	0,134	0,8	R	A05.R L A05.L
5,0	28	15,2	5,2	+	A05.BS28.02.15.52 MR/L	R ABB4 L AGQA	X800 X400	4,95	3,75	2,45	0,581	18,0	0,907	0,124	0,8	R	A05.R L A05.L
▼ ØDmin (Min. Bohrung) // ØDmin (min. bore) = 6,2 mm																	
6,0	19	15,2	6,2	+	A06.BS19.02.15.62 MR/L	R AHFD L ANAY	X800 X400	5,95	3,95	2,95	0,856	18,0	1,337	0,183	1,0	R	A06.R L A06.L
6,0	20	15,2	6,2	+	A06.BS20.02.15.62 MR/L	R AHVF L AAVT	X800 X400	5,95	3,95	2,95	0,813	18,0	1,27	0,174	1,0	R	A06.R L A06.L
6,0	22	15,2	6,2	+	A06.BS22.02.15.62 MR/L	R AGES L AKD7	X800 X400	5,95	3,95	2,95	0,739	18,0	1,155	0,158	1,0	R	A06.R L A06.L
6,0	24	15,2	6,2	+	A06.BS24.02.15.62 MR/L	R AKC7 L AFWW	X800 X400	5,95	3,95	2,95	0,677	18,0	1,058	0,145	0,8	R	A06.R L A06.L
6,0	26	15,2	6,2	+	A06.BS26.02.15.62 MR/L	R AMDA L AJ45	X800 X400	5,95	3,95	2,95	0,625	18,0	0,977	0,134	0,8	R	A06.R L A06.L
6,0	28	15,2	6,2	+	A06.BS28.02.15.62 MR/L	R AFKD L AA9Q	X800 X400	5,95	3,95	2,95	0,581	18,0	0,907	0,124	0,8	R	A06.R L A06.L

Bestellbeispiel // Order example: **A06.BS19.02.15.62 MR X800** (R = Rechte Ausführung // Right hand version, X800 = Schneidstoff // Grade)

Gewindedrehen, ACME Teilprofil

Teilprofil für ACME Gewinde.

Threading, ACME Partial Profile

Partial profile for internal ACME threads.

Schnittwerte (Start) // Cutting parameters (start)

f	Vc
0,02 mm/U	Seite/Page 429

Empf. Zustellungsart // Recom. infeed method
Flankenzustellung // Flank infeed (Seite/Page 433)

Passende Klemmhalter auf Seite // Suitable toolholders on page

- 27, 28, 29, 31, 33, 35, 36, 37, 41,
- 42, 44, 45, 46, 50, 51, 52, 53, 54,
- 55, 56, 57, 58, 61, 62, 63, 64, 65,
- 66, 67, 68, 69

SP

HM

R

Scan QR-Code
 Oder besuchen Sie // Or Visit
www.simtek.info/cp/1292

Legende Legend **139**

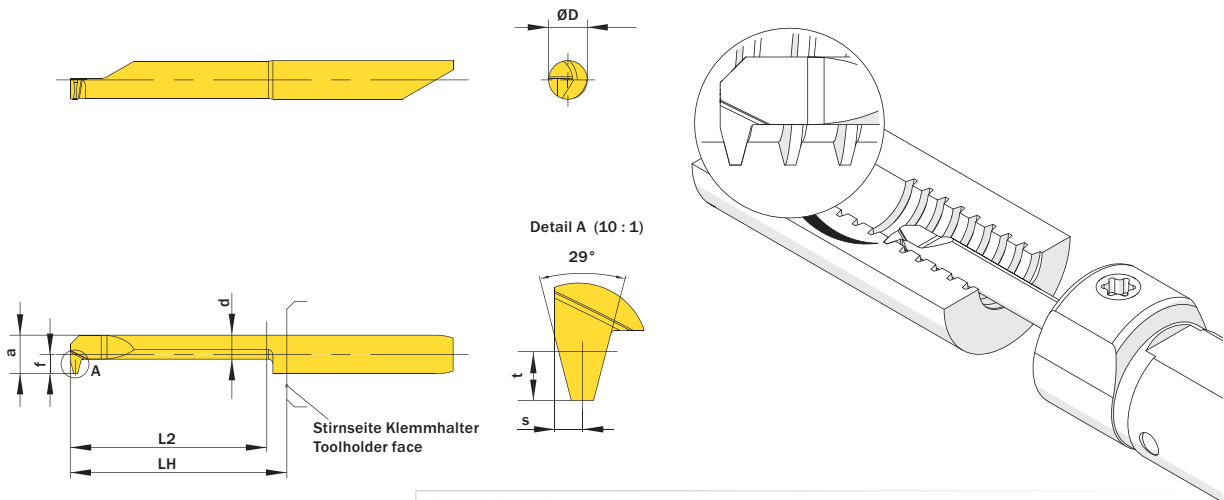


Abbildung zeigt / Drawing shows: A05.AC16.01.25.52 MR

Mehr Informationen zur Kühlmittelzufuhr finden Sie auf Seite 22
Additional information about through coolant supply on page 22

ØD	Gang/Zoll Threads/inch	L2	ØDmin (Min. Bohrung) ØDmin (min. bore)	Kühlmittelzufuhr Through coolant supply	Artikelnummer Part number	Webcode www.simtek.com/webcode	Unsere erste Wahl Our first choice	a	d	f	LH	S	t	Connectcode www.simtek.com/code
mm		mm	mm				P K M N S	mm	mm	mm	mm	mm	mm	
5,0	16	25,4	5,2	+	A05.AC16.01.25.52 MR	A2A8	X800 X400	4,95	3,1	2,45	28,0	0,7	1,05	A05.R
6,0	14	25,4	6,2	+	A06.AC14.01.25.62 MR	A2A9	X800 X400	5,95	4,3	2,95	28,0	0,9	1,17	A06.R
7,0	10	30,5	7,2	+	A07.AC10.01.30.72 MR	A2BB	X800 X400	6,95	4,4	3,45	33,0	1,0	1,78	A07.R
7,0	12	30,5	7,2	+	A07.AC12.01.30.72 MR	A2BA	X800 X400	6,95	4,8	3,45	33,0	1,0	1,32	A07.R

Bestellbeispiel // Order example: **A05.AC16.01.25.52 MR X800** (R = Rechte Ausführung // Right hand version, X800 = Schneidstoff // Grade)

Gewindedrehen, STUB-ACME Teilprofil

STUB-ACME Gewinde, Teilprofil, Innen.

Threading, STUB-ACME Partial Profile

STUB-ACME threads, partial profile, internal.

Schnittwerte (Start) // Cutting parameters (start)

f	Vc
0,02 mm/U	Seite/Page 429

Empf. Zustellungsart // Recom. infeed method
Flankenzustellung // Flank infeed (Seite/Page 433)

Passende Klemmhalter auf Seite // Suitable toolholders on page

- 27, 28, 29, 31, 33, 35, 36, 37, 41,
- 42, 44, 45, 46, 50, 51, 52, 53, 54,
- 55, 56, 57, 58, 61, 62, 63, 64, 65,
- 66, 67, 68, 69

SP

HM

R

Scan QR-Code

Legende
Legend **139**

Oder besuchen Sie // Or Visit
www.simtek.info/cp/1338

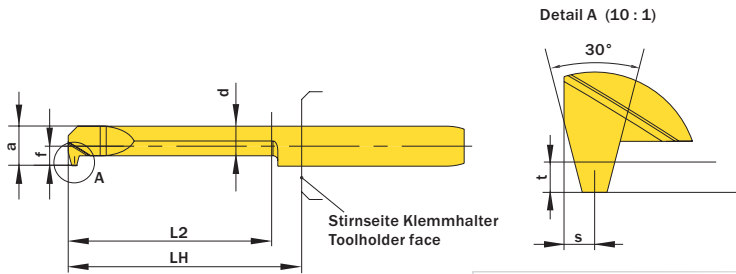
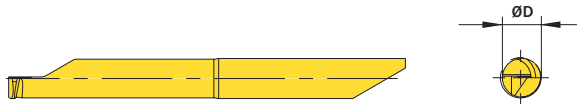


Abbildung zeigt / Drawing shows: A05.SA16.01.25.52 MR

Mehr Informationen zur Kühlmittelzufuhr finden Sie auf Seite 22
 Additional information about through coolant supply on page 22

ØD	Gang/Zoll Threads/inch	L2	ØDmin (Min. Bohrung) ØDmin (min. bore)	Kühlmittelzufuhr Through coolant supply	Artikelnummer Part number	Webcode www.simtek.com/webcode	Unsere erste Wahl Our first choice		a	d	f	LH	S	t	Connectcode www.simtek.com/code	
							P	K M N S								
5,0	16	25,4	5,2	+	A05.SA16.01.25.52 MR	A5A7	X800	X400	4,95	3,7	2,45	28,0	0,8	0,92	A05.R	new
6,0	14	25,4	6,2	+	A06.SA14.01.25.62 MR	A5A9	X800	X400	5,95	4,6	2,95	28,0	0,7	0,82	A06.R	new
7,0	10	30,5	7,2	+	A07.SA10.01.30.72 MR	A5BB	X800	X400	6,95	5,1	3,45	33,0	0,9	1,19	A07.R	new
7,0	12	30,5	7,2	+	A07.SA12.01.30.72 MR	A5BD	X800	X400	6,95	5,5	3,45	33,0	0,8	0,92	A07.R	new

Bestellbeispiel // Order example: **A05.SA16.01.25.52 MR X800** (R = Rechte Ausführung // Right hand version, X800 = Schneidstoff // Grade)

Axialstechen

Geeignet ab Bohrungsdurchmesser 3,0 mm.

Face Grooving

Inner diameter of groove starting at 3,0 mm.

Schnittwerte (Start) // Cutting parameters (start)

f	Vc
0,02 mm/U	Seite/Page 429

Passende Klemmhalter auf Seite // Suitable toolholders on page

26, 31, 33, 34, 40, 41, 43, 50, 51,
53, 55, 56, 57, 60, 62, 63, 65, 66,
67, 68, 69

SP

HM

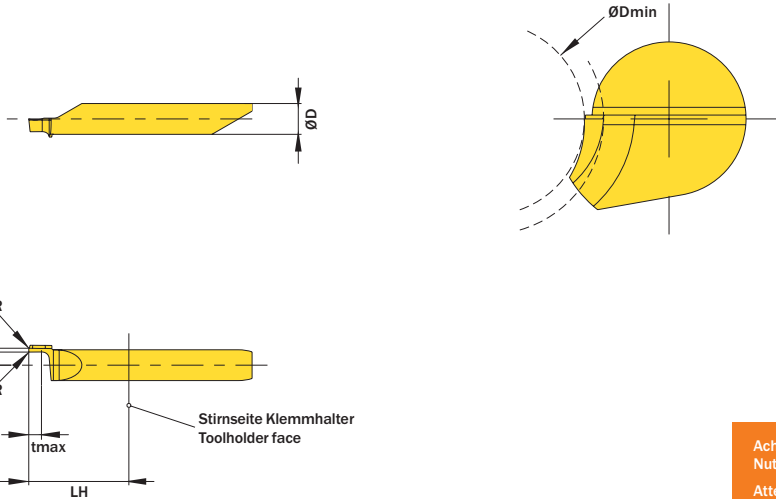
R

Legende
Legend

139

Scan
QR-Code

Oder besuchen Sie // Or Visit
www.simtek.info/cp/1378



Achtung: Die Bearbeitung muss stets vom kleinsten Nutinnendurchmesser aus beginnen.
Attention: Machining process must always start at the smallest internal groove diameter.

Abbildung zeigt / Drawing shows: A04.56.0050.13.00 AG R

ØD	ab Nutinnendurchmesser as of inner groove diameter	w ^{+0,05}	LH	R	Artikelnummer Part number	Webcode www.simtek.com/webcode	Unsere erste Wahl Our first choice	f	tmax	Connectcode www.simtek.com/code	
mm	mm	mm	mm	mm			P K M N S	mm	mm		
▼ ØDmin (Min. Bohrung) // ØDmin (min. bore) = 3,0 mm											
4,0	3,0	0,5	13,0	-	A04.34.0050.13.00 AG R	A2U4	X800 X400	2,2	1,6	A04.R	new
▼ ØDmin (Min. Bohrung) // ØDmin (min. bore) = 4,0 mm											
4,0	4,0	0,5	13,0	-	A04.45.0050.13.00 AG R	A2U5	X800 X400	2,2	1,6	A04.R	new
4,0	4,0	1,0	13,0	-	A04.46.0100.13.00 AG R	A2VA	X800 X400	2,2	3,3	A04.R	new
▼ ØDmin (Min. Bohrung) // ØDmin (min. bore) = 5,0 mm											
4,0	5,0	0,5	13,0	-	A04.56.0050.13.00 AG R	A6K1	X800 X400	2,2	1,6	A04.R	new

Bestellbeispiel // Order example: **A04.46.0100.13.00 AG R X800** (R = Rechte Ausführung // Right hand version, X800 = Schneidstoff // Grade)

Axialstechen in Bohrungen

Geeignet ab Bohrungsdurchmesser 6,2 mm.

Face Grooving in Bores

For use in bores as of minimum bore diameter 6,2 mm.

Schnittwerte (Start) // Cutting parameters (start)

f	Vc
0,02 mm/U	Seite/Page 429

Passende Klemmhalter auf Seite // Suitable toolholders on page

28, 31, 36, 42, 45, 50, 51, 53, 55, 56, 58, 61, 62, 64, 65, 66, 67, 68, 69



SP **HM** **R** **Legende** **139**
Legend

Scan QR-Code Oder besuchen Sie // Or Visit www.simtek.info/cp/759

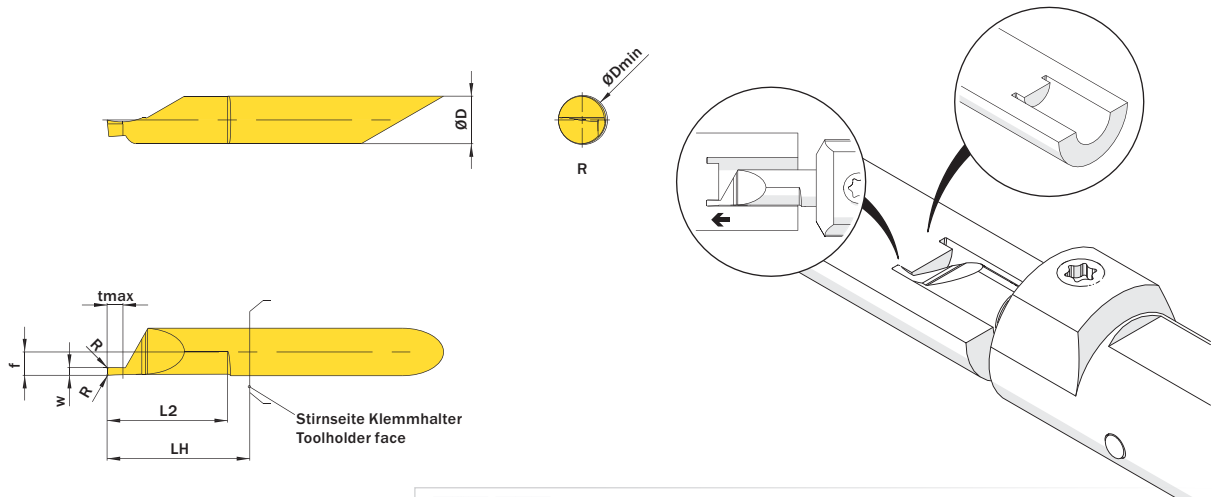
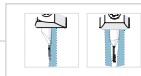


Abbildung zeigt / Drawing shows: A06.0100.15.01 AG R



Mehr Informationen zur Kühlmittelzufuhr finden Sie auf Seite 22
Additional information about through coolant supply on page 22

ØD	w ^{+0,05}	L2	Kühlmittelzufuhr Through coolant supply	Artikelnummer Part number	Webcode www.simtek.com/webcode	Unsere erste Wahl Our first choice	ØDmin (Min. Bohrung) ØDmin (min. bore)	f	LH	R	tmax	Connectcode www.simtek.com/code
mm	mm	mm				P K M N S	mm	mm	mm	mm	mm	
▼ R = 0,05 mm												
6,0	0,787	15,2	+	A06.0078.15.01.05 AG R/L	R AYU8 L AYU9	X800 X400	6,2	2,95	18,0	0,05	1,8	R A06.R L A06.L Inch
6,0	1,0	15,2	+	A06.0100.15.01.05 AG R/L	R AYU7 L AYU1	X800 X400	6,2	2,95	18,0	0,05	2,0	R A06.R L A06.L
6,0	1,5	15,2	+	A06.0150.15.01.05 AG R/L	R AYVA L AYVB	X800 X400	6,2	2,95	18,0	0,05	3,0	R A06.R L A06.L
▼ R = 0,15 mm												
6,0	1,0	15,2	+	A06.0100.15.01 AG R/L	R AB01 L AH2V	X800 X400	6,2	2,95	18,0	0,15	2,0	R A06.R L A06.L
6,0	1,168	15,2	+	A06.0117.15.01 AG R/L	R ANY2 L AP1G	X800 X400	6,2	2,95	18,0	0,15	2,34	R A06.R L A06.L Inch
6,0	1,5	15,2	+	A06.0150.15.01 AG R/L	R AMN7 L AHFP	X800 X400	6,2	2,95	18,0	0,15	3,0	R A06.R L A06.L
6,0	1,575	15,2	+	A06.0157.15.01 AG R/L	R ANJ5 L AG36	X800 X400	6,2	2,95	18,0	0,15	3,15	R A06.R L A06.L Inch
6,0	1,981	15,2	+	A06.0198.15.01 AG R/L	R AEBQ L APCJ	X800 X400	6,2	2,95	18,0	0,15	3,95	R A06.R L A06.L Inch
6,0	2,0	15,2	+	A06.0200.15.01 AG R/L	R AJ67 L AMKX	X800 X400	6,2	2,95	18,0	0,15	4,0	R A06.R L A06.L
6,0	2,388	15,2	+	A06.0239.15.01 AG R/L	R AF9A L ACZ4	X800 X400	6,2	2,95	18,0	0,15	5,0	R A06.R L A06.L Inch
6,0	2,5	15,2	+	A06.0250.15.01 AG R/L	R AHG4 L AGS3	X800 X400	6,2	2,95	18,0	0,15	5,0	R A06.R L A06.L
6,0	3,0	15,2	+	A06.0300.15.01 AG R/L	R ABX0 L AGAS	X800 X400	6,2	2,95	18,0	0,15	6,0	R A06.R L A06.L
6,0	3,175	15,2	+	A06.0318.15.01 AG R/L	R AM8N L AMGF	X800 X400	6,2	2,95	18,0	0,15	6,0	R A06.R L A06.L Inch

Bestellbeispiel // Order example: **A06.0100.15.01.05 AG R X800** (R = Rechte Ausführung // Right hand version, X800 = Schneidstoff // Grade)

Axialstechen an Zapfen

Geeignet ab Bohrungsdurchmesser 6,2 mm.

Face Grooving on Pivots

For use in bores as of minimum bore diameter 6,2 mm.

Schnittwerte (Start) // Cutting parameters (start)

f	Vc
0,02 mm/U	Seite/Page 429

Passende Klemmhalter auf Seite // Suitable toolholders on page

28, 31, 36, 42, 45, 50, 51, 53, 55, 56, 58, 61, 62, 64, 65, 66, 67, 68, 69



SP
HM
R

Legende
Legend **139**

Scan
QR-Code

Oder besuchen Sie // Or Visit
www.simtek.info/cp/760

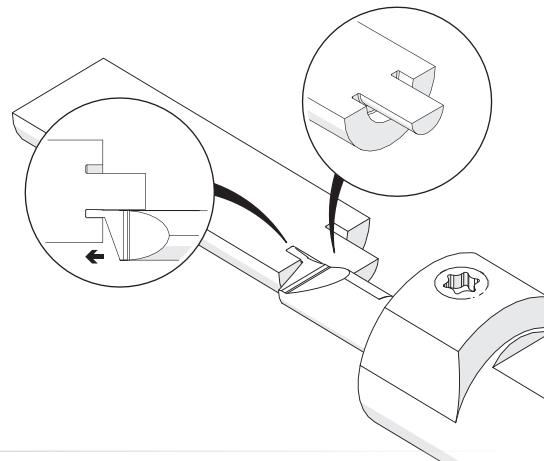
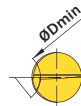
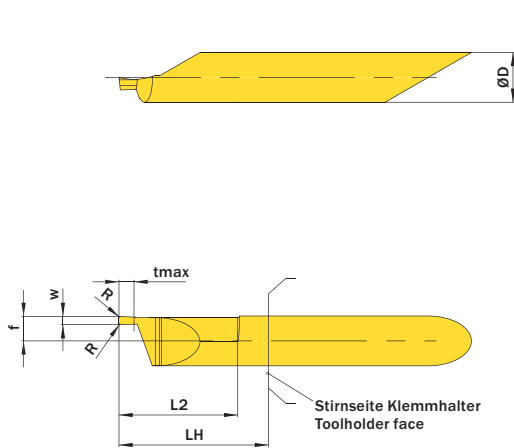


Abbildung zeigt / Drawing shows: A06.0100.15.02 AG R

Mehr Informationen zur Kühlmittelzufuhr finden Sie auf Seite 22
Additional information about through coolant supply on page 22

ØD	w ^{+0,05}	L2	Kühlmittelzufuhr Through coolant supply	Artikelnummer Part number	Webcode www.simtek.com/webcode	Unsere erste Wahl Our first choice				ØDmin (Min. Bohrung) ØDmin (min. bore)	f	LH	R	tmax	Connectcode www.simtek.com/code		Inch
						P	K	M	S						R	L	
6,0	0,787	15,2	+	A06.0078.15.02.05 AG R/L	R AYVG L AYVJ	X800	X400			6,2	2,95	18,0	0,05	1,8	R A06.L	L A06.R	
6,0	1,0	15,2	+	A06.0100.15.02 AG R/L	R ABQA L AETM	X800	X400			6,2	2,95	18,0	0,15	2,0	R A06.L	L A06.R	inch
6,0	1,0	15,2	+	A06.0100.15.02.05 AG R/L	R AYVE L AYVF	X800	X400			6,2	2,95	18,0	0,05	2,0	R A06.L	L A06.R	
6,0	1,168	15,2	+	A06.0117.15.02 AG R/L	R AAUY L AGYT	X800	X400			6,2	2,95	18,0	0,15	2,34	R A06.L	L A06.R	inch
6,0	1,5	15,2	+	A06.0150.15.02 AG R/L	R AN6W L AMBS	X800	X400			6,2	2,95	18,0	0,15	3,0	R A06.L	L A06.R	
6,0	1,5	15,2	+	A06.0150.15.02.05 AG R/L	R AYVC L AYVD	X800	X400			6,2	2,95	18,0	0,05	3,0	R A06.L	L A06.R	
6,0	1,575	15,2	+	A06.0157.15.02 AG R/L	R ANGN L ABMM	X800	X400			6,2	2,95	18,0	0,15	3,15	R A06.L	L A06.R	inch
6,0	1,981	15,2	+	A06.0198.15.02 AG R/L	R AC8Q L ABEM	X800	X400			6,2	2,95	18,0	0,15	3,95	R A06.L	L A06.R	inch
6,0	2,0	15,2	+	A06.0200.15.02 AG R/L	R AA2D L AK6M	X800	X400			6,2	2,95	18,0	0,15	4,0	R A06.L	L A06.R	
6,0	2,388	15,2	+	A06.0239.15.02 AG R/L	R AH42 L AJSW	X800	X400			6,2	2,95	18,0	0,15	5,0	R A06.L	L A06.R	inch
6,0	2,5	15,2	+	A06.0250.15.02 AG R/L	R AG4W L APF4	X800	X400			6,2	2,95	18,0	0,15	5,0	R A06.L	L A06.R	
6,0	3,0	15,2	+	A06.0300.15.02 AG R/L	R ABGJ L AJNY	X800	X400			6,2	2,95	18,0	0,15	6,0	R A06.L	L A06.R	
6,0	3,175	15,2	+	A06.0318.15.02 AG R/L	R ABXE L AN9H	X800	X400			6,2	2,95	18,0	0,15	6,0	R A06.L	L A06.R	inch

Bestellbeispiel // Order example: **A06.0200.15.02 AG R X800** (R = Rechte Ausführung // Right hand version, X800 = Schneidstoff // Grade)

simturn AX
simturn DX
simturn PX
simturn H2
simturn K2
simturn C4
simturn GX
simturn E3
simturn E12
simturn FX
simturn Decolletage
simturn OA
Index

Axialstechen in Bohrungen

Volle Stechtiefe ab Bohrungsdurchmesser 16,0 mm.
Reduzierte Stechtiefe bereits ab Bohrungsdurchmesser 10,0 mm.



Face Grooving in Bores

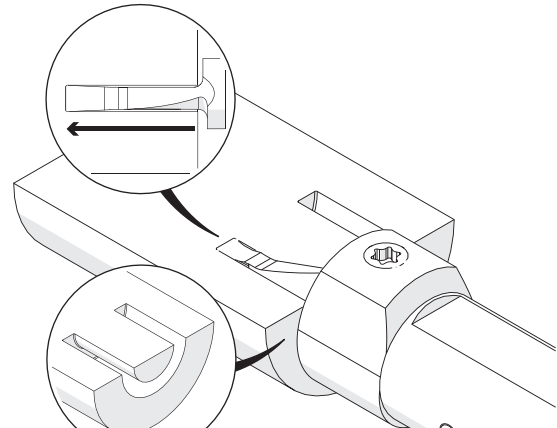
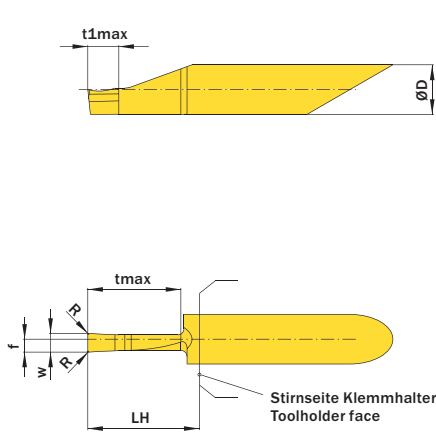
Full cutting depth as of minimum bore diameter 16,0 mm.
Reduced cutting depth possible as of minimum bore diameter 10,0 mm.

Schnittwerte (Start) // Cutting parameters (start)

f	Vc
0,02 mm/U	Seite/Page 429

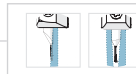
Passende Klemmhalter auf Seite // Suitable toolholders on page
30, 38, 47, 52, 54, 59, 67, 68, 69



 Legende Legend **139**
 Scan QR-Code Oder besuchen Sie // Or Visit www.simtek.info/cp/761



Stechtiefe „tmax“ gilt ab Bohrungsdurchmesser gem. Angabe in Spalte „Ab Bohrungsdurchmesser“
Stechtiefe „t1max“ gilt ab Bohrungsdurchmesser gem. Angabe in Spalte „D1min“
Cutting depth „tmax“ is possible as of bore diameter as stated in column „As of bore diameter“
Cutting depth „t1max“ is possible as of bore diameter as stated in column „D1min“

Abbildung zeigt / Drawing shows: A08.0300.15.00 AG R



Mehr Informationen zur Kühlmittelzufuhr finden Sie auf Seite 22
Additional information about through coolant supply on page 22

ØD	w ^{+0,05}	tmax	Kühlmittelzufuhr Through coolant supply	Artikelnummer Part number	Webcode www.simtek.com/webcode	Unsere erste Wahl Our first choice	ØDmin (Min. Bohrung) ØDmin (min. bore)	t1max	D1min	f	LH	R	Connectcode www.simtek.com/ccode	
mm	mm	mm				P K M N S	mm	mm	mm	mm	mm	mm		
▼ w = 2,0 mm														
8,0	2,0	10,0	+	A08.0200.10.00 AG R/L	R AV5V	L AV5U	X800 X400	16,0	-	-	1,51	15,0	0,2	A08
8,0	2,0	15,0	+	A08.0200.15.00 AG R/L	R AKK7	L AHEV	X800 X400	16,0	-	-	1,51	20,0	0,2	A08
▼ w = 2,5 mm														
8,0	2,5	10,0	+	A08.0250.10.00 AG R/L	R ABJN	L AMFN	X800 X400	16,0	3,0	10,0	1,8	15,0	0,2	A08
8,0	2,5	15,0	+	A08.0250.15.00 AG R/L	R AV5Z	L AV5Y	X800 X400	16,0	3,0	10,0	1,8	20,0	0,2	A08
▼ w = 3,0 mm														
8,0	3,0	10,0	+	A08.0300.10.00 AG R/L	R ANH7	L AGHC	X800 X400	16,0	3,0	10,0	2,07	15,0	0,2	A08
8,0	3,0	15,0	+	A08.0300.15.00 AG R/L	R APG2	L AF4K	X800 X400	16,0	3,0	10,0	2,07	20,0	0,2	A08
▼ w = 4,0 mm														
8,0	4,0	10,0	+	A08.0400.10.00 AG R/L	R AFJ9	L AFV6	X800 X400	16,0	3,0	10,0	2,49	15,0	0,2	A08
8,0	4,0	15,0	+	A08.0400.15.00 AG R/L	R AMQ5	L AEWV	X800 X400	16,0	3,0	10,0	2,49	20,0	0,2	A08

Bestellbeispiel // Order example: **A08.0200.10.00 AG R X800** (R = Rechte Ausführung // Right hand version, X800 = Schneidstoff // Grade)

Axialstechen in Bohrungen

Volle Stechtiefe ab Bohrungsdurchmesser 16,0 mm.
Schneidwerkzeuge mit integriertem Kühlmittelkanal.

Face Grooving in Bores

Full cutting depth as of minimum bore diameter
16,0 mm. Inserts with through coolant.

Schnittwerte (Start) // Cutting parameters (start)

f	Vc
0,02 mm/U	Seite/Page 429

Passende Klemmhalter auf Seite // Suitable toolholders on page
38, 47, 49, 52, 54, 59, 67, 68, 69

SP

HM

R

Legende

139

Scan QR-Code Oder besuchen Sie // Or Visit www.simtek.info/cp/999

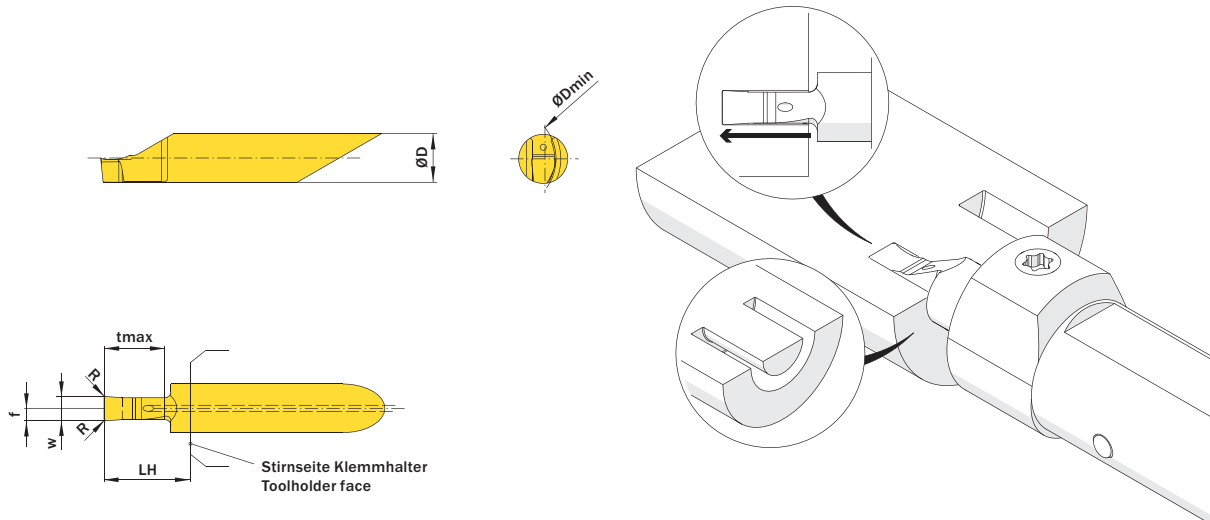
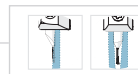


Abbildung zeigt / Drawing shows: A08.0400.10.00 TAG R



Mehr Informationen zur Kühlmittelzufuhr finden Sie auf Seite 22
Additional information about through coolant supply on page 22

ØD	w ^{+0,05}	tmax	Kühlmittelzufuhr Through coolant supply	Artikelnummer Part number	Webcode www.simtek.com/webcode	Unsere erste Wahl Our first choice	ØDmin (Min. Bohrung) ØDmin (min. bore)	f	LH	R	Connectcode www.simtek.com/code
mm	mm	mm				P K M N S	mm	mm	mm	mm	
▼ w = 2,0 mm											
8,0	2,0	10,0	+	A08.0200.10.00 TAG R/L	R AV5X L AV5W	X800 X400	16,0	1,51	15,0	0,2	A08T
8,0	2,0	15,0	+	A08.0200.15.00 TAG R/L	R AVZ1 L AVZZ	X800 X400	16,0	1,51	20,0	0,2	A08T
▼ w = 2,5 mm											
8,0	2,5	10,0	+	A08.0250.10.00 TAG R/L	R AVZ5 L AVZ3	X800 X400	16,0	1,8	15,0	0,2	A08T
8,0	2,5	15,0	+	A08.0250.15.00 TAG R/L	R AV51 L AV50	X800 X400	16,0	1,8	20,0	0,2	A08T
▼ w = 3,0 mm											
8,0	3,0	10,0	+	A08.0300.10.00 TAG R/L	R AV0A L AVZ7	X800 X400	16,0	2,07	15,0	0,2	A08T
8,0	3,0	15,0	+	A08.0300.15.00 TAG R/L	R AV0G L AV0D	X800 X400	16,0	2,07	20,0	0,2	A08T
▼ w = 4,0 mm											
8,0	4,0	10,0	+	A08.0400.10.00 TAG R/L	R AV0P L AV0K	X800 X400	16,0	2,49	15,0	0,2	A08T
8,0	4,0	15,0	+	A08.0400.15.00 TAG R/L	R AV0W L AV0T	X800 X400	16,0	2,49	20,0	0,2	A08T

Bestellbeispiel // Order example: **A08.0400.10.00 TAG R X800** (R = Rechte Ausführung // Right hand version, X800 = Schneidstoff // Grade)

Axialstechen in Bohrungen

Volle Stechtiefe ab Bohrungsdurchmesser 20,0 mm.
Reduzierte Stechtiefe bereits ab Bohrungsdurchmesser 12,0 mm.

Face Grooving in Bores

Full cutting depth as of minimum bore diameter 20,0 mm.
Reduced cutting depth possible as of minimum bore diameter 12,0 mm.

Schnittwerte (Start) // Cutting parameters (start)

f	Vc
0,02 mm/U	Seite/Page 429

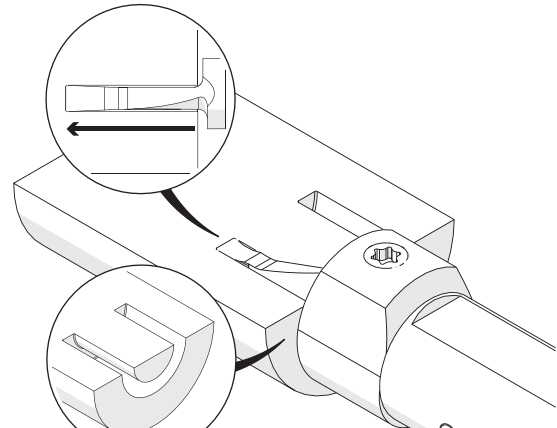
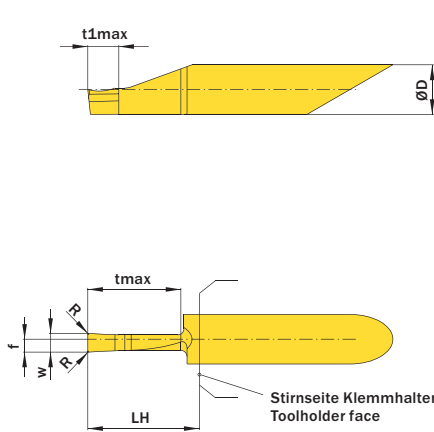
Passende Klemmhalter auf Seite // Suitable toolholders on page
30, 39, 48, 52, 54, 59, 68



Legende
Legend **139**

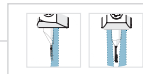
Scan
QR-Code

Oder besuchen Sie // Or Visit
www.simtek.info/cp/762



Stechtiefe „tmax“ gilt ab Bohrungsdurchmesser gem. Angabe in Spalte „Ab Bohrungsdurchmesser“
Stechtiefe „t1max“ gilt ab Bohrungsdurchmesser gem. Angabe in Spalte „D1min“
Cutting depth „tmax“ is possible as of bore diameter as stated in column „As of bore diameter“
Cutting depth „t1max“ is possible as of bore diameter as stated in column „D1min“

Abbildung zeigt / Drawing shows: A08.0300.15.00 AG R



Mehr Informationen zur Kühlmittelzufuhr finden Sie auf Seite 22
Additional information about through coolant supply on page 22

ØD	w ^{+0,05}	tmax	Kühlmittelzufuhr Through coolant supply	Artikelnummer Part number	Webcode www.simtek.com/webcode	Unsere erste Wahl Our first choice	ØDmin (Min. Bohrung) ØDmin (min. bore)	t1max	D1min	f	LH	R	Connectcode www.simtek.com/code
mm	mm	mm				P K M N S	mm	mm	mm	mm	mm	mm	
▼ w = 3,0 mm													
10,0	3,0	20,0	+	A10.0300.20.00 AG R/L	R AAUC	L ABVX X800 X400	20,0	5,0	12,0	2,07	28,0	0,2	R A10.R L A10.L
10,0	3,0	25,0	+	A10.0300.25.00 AG R/L	R AENK	L AEYQ X800 X400	20,0	5,0	12,0	2,07	33,0	0,2	R A10.R L A10.L
10,0	3,0	30,0	+	A10.0300.30.00 AG R/L	R AP2X	L APZ8 X800 X400	20,0	5,0	12,0	2,07	38,0	0,2	R A10.R L A10.L
▼ w = 4,0 mm													
10,0	4,0	20,0	+	A10.0400.20.00 AG R/L	R AMDH	L AJPZ X800 X400	20,0	5,0	12,0	2,65	28,0	0,2	R A10.R L A10.L
10,0	4,0	25,0	+	A10.0400.25.00 AG R/L	R AMKB	L AME8 X800 X400	20,0	5,0	12,0	2,65	33,0	0,2	R A10.R L A10.L
10,0	4,0	30,0	+	A10.0400.30.00 AG R/L	R AKHQ	L AB12 X800 X400	20,0	5,0	12,0	2,65	38,0	0,2	R A10.R L A10.L
▼ w = 5,0 mm													
10,0	5,0	20,0	+	A10.0500.20.00 AG R/L	R AKXP	L AAXF X800 X400	20,0	5,0	12,0	3,1	28,0	0,2	R A10.R L A10.L
10,0	5,0	25,0	+	A10.0500.25.00 AG R/L	R AA6G	L AH2U X800 X400	20,0	5,0	12,0	3,1	33,0	0,2	R A10.R L A10.L
10,0	5,0	30,0	+	A10.0500.30.00 AG R/L	R AFJH	L AN46 X800 X400	20,0	5,0	12,0	3,1	38,0	0,2	R A10.R L A10.L

Bestellbeispiel // Order example: **A10.0300.20.00 AG R X800** (R = Rechte Ausführung // Right hand version, X800 = Schneidstoff // Grade)

Axialstechen in Bohrungen

Volle Stechtiefe ab Bohrungsdurchmesser 20,0 mm.
Schneidwerkzeuge mit integriertem Kühlmittelkanal.

Face Grooving in Bores

Full cutting depth as of minimum bore diameter 20,0 mm. Inserts with through coolant.

Schnittwerte (Start) // Cutting parameters (start)

f	Vc
0,02 mm/U	Seite/Page 429

Passende Klemmhalter auf Seite // Suitable toolholders on page
39, 48, 52, 54, 59, 68

SP

HM

R

Legende

139

Scan QR-Code Oder besuchen Sie // Or Visit www.simtek.info/cp/1000

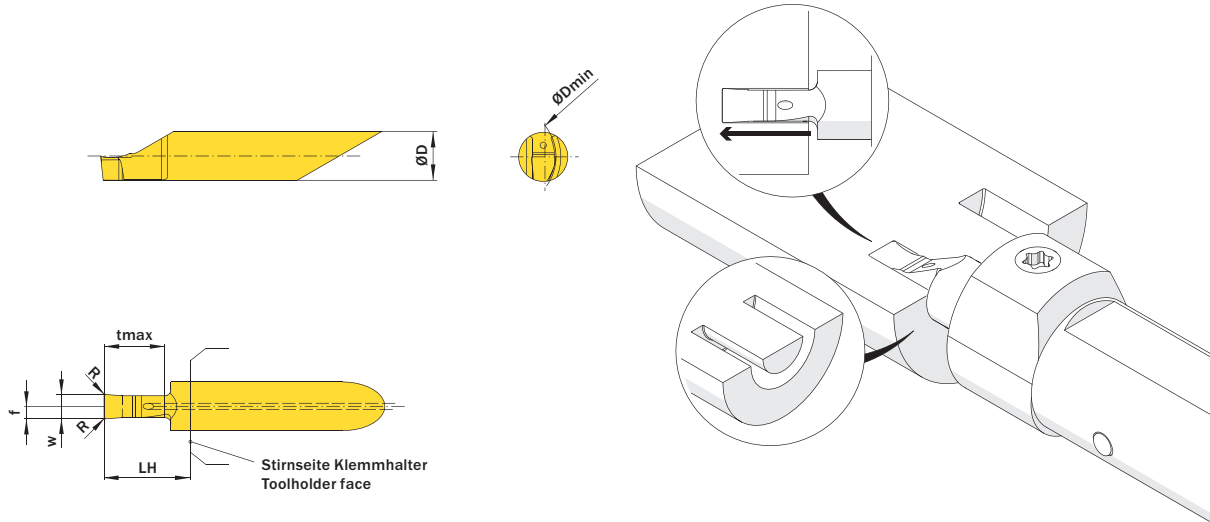
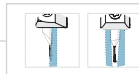


Abbildung zeigt / Drawing shows: A08.0400.10.00 TAG R



Mehr Informationen zur Kühlmittelzufuhr finden Sie auf Seite 22
Additional information about through coolant supply on page 22

ØD	w ^{+0,05}	tmax	Kühlmittelzufuhr Through coolant supply	Artikelnummer Part number	Webcode www.simtek.com/webcode	Unsere erste Wahl Our first choice	ØDmin (Min. Bohrung) ØDmin (min. bore)	f	LH	R	Connectcode www.simtek.com/code
mm	mm	mm				P K M N S	mm	mm	mm	mm	
▼ w = 3,0 mm											
10,0	3,0	20,0	+	A10.0300.20.00 TAG R/L	R AV02 L AV0Z	X800 X400	20,0	2,07	28,0	0,2	A10T
10,0	3,0	25,0	+	A10.0300.25.00 TAG R/L	R AV08 L AV05	X800 X400	20,0	2,07	33,0	0,2	A10T
10,0	3,0	30,0	+	A10.0300.30.00 TAG R/L	R AV1E L AV1B	X800 X400	20,0	2,07	38,0	0,2	A10T
▼ w = 4,0 mm											
10,0	4,0	20,0	+	A10.0400.20.00 TAG R/L	R AV1M L AV1H	X800 X400	20,0	2,65	28,0	0,2	A10T
10,0	4,0	25,0	+	A10.0400.25.00 TAG R/L	R AV1U L AV1Q	X800 X400	20,0	2,65	33,0	0,2	A10T
10,0	4,0	30,0	+	A10.0400.30.00 TAG R/L	R AV10 L AV1X	X800 X400	20,0	2,65	38,0	0,2	A10T
10,0	4,0	40,0	+	A10.0400.40.00 TAG R/L	R A6UD L A6UF	X800 X400	20,0	2,65	43,0	0,2	A10T new
▼ w = 5,0 mm											
10,0	5,0	20,0	+	A10.0500.20.00 TAG R/L	R AV16 L AV13	X800 X400	20,0	3,1	28,0	0,2	A10T
10,0	5,0	25,0	+	A10.0500.25.00 TAG R/L	R AV2C L AV19	X800 X400	20,0	3,1	33,0	0,2	A10T
10,0	5,0	30,0	+	A10.0500.30.00 TAG R/L	R AV2J L AV2F	X800 X400	20,0	3,1	38,0	0,2	A10T

Bestellbeispiel // Order example: **A10.0300.20.00 TAG R X800** (R = Rechte Ausführung // Right hand version, X800 = Schneidstoff // Grade)

Axialstechen in Bohrungen, Vollradius

Geeignet ab Bohrungsdurchmesser 6,2 mm.

Full Radius Face Grooving in Bores

For use in bores as of minimum bore diameter 6,2 mm.

Schnittwerte (Start) // Cutting parameters (start)

f	Vc
0,02 mm/U	Seite/Page 429

Passende Klemmhalter auf Seite // Suitable toolholders on page

28, 31, 36, 42, 45, 50, 51, 53, 55, 56, 58, 61, 62, 64, 65, 66, 67, 68, 69



Legende
Legend **139**

Scan
QR-Code

Oder besuchen Sie // Or Visit
www.simtek.info/cp/763

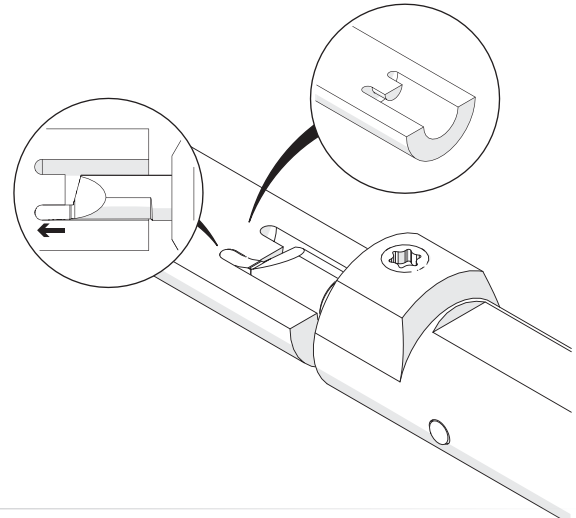
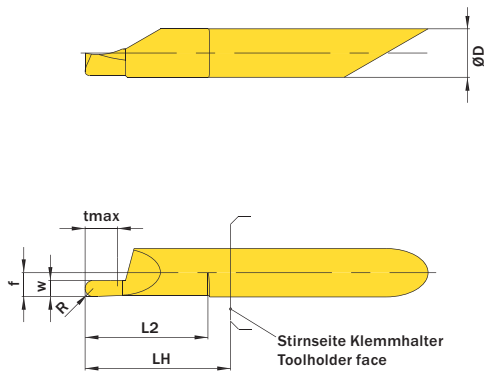
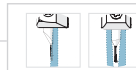


Abbildung zeigt / Drawing shows: A06.0200.15.01 AV R



Mehr Informationen zur Kühlmittelzufuhr finden Sie auf Seite 22
Additional information about through coolant supply on page 22

ØD	w ^{+0,05}	L2	Kühlmittelzufuhr Through coolant supply	Artikelnummer Part number	Webcode www.simtek.com/webcode	Unsere erste Wahl Our first choice	ØDmin (Min. Bohrung) ØDmin (min. bore)	f	LH	R	tmax	Connectcode www.simtek.com/code
mm	mm	mm				P K M N S	mm	mm	mm	mm	mm	
6,0	1,0	15,2	+	A06.0100.15.01 AV R/L	R AE1C L AKM6	X800 X400	6,2	2,95	18,0	0,5	2,0	R A06.R L A06.L
6,0	1,575	15,2	+	A06.0157.15.01 AV R	A6MD	X800 X400	6,2	2,95	18,0	0,785	3,0	A06.R <small>new inch</small>
6,0	1,6	15,2	+	A06.0160.15.01 AV R/L	R AJPQ L AGG4	X800 X400	6,2	2,95	18,0	0,8	3,0	R A06.R L A06.L
6,0	2,0	15,2	+	A06.0200.15.01 AV R/L	R AB30 L AGFY	X800 X400	6,2	2,95	18,0	1,0	4,0	R A06.R L A06.L
6,0	2,39	15,2	+	A06.0239.15.01 AV R	A6MB	X800 X400	6,2	2,95	18,0	1,245	5,0	A06.R <small>new inch</small>
6,0	2,5	15,2	+	A06.0250.15.01 AV R/L	R AAE4 L AK4E	X800 X400	6,2	2,95	18,0	1,25	5,0	R A06.R L A06.L
6,0	3,0	15,2	+	A06.0300.15.01 AV R/L	R AF07 L AGBB	X800 X400	6,2	2,95	18,0	1,5	6,0	R A06.R L A06.L

Bestellbeispiel // Order example: **A06.0100.15.01 AV R X800** (R = Rechte Ausführung // Right hand version, X800 = Schneidstoff // Grade)

Axialstechen an Zapfen, Vollradius

Geeignet ab Bohrungsdurchmesser 6,2 mm.

Full Radius Face Grooving on Pivots

For use in bores as of minimum bore diameter 6,2 mm.

Schnittwerte (Start) // Cutting parameters (start)

f	Vc
0,02 mm/U	Seite/Page 429

Passende Klemmhalter auf Seite // Suitable toolholders on page

28, 31, 36, 42, 45, 50, 51, 53, 55, 56, 58, 61, 62, 64, 65, 66, 67, 68, 69



SP **HM** **R** Legende Legend **139**

Scan QR-Code Oder besuchen Sie // Or Visit www.simtek.info/cp/803

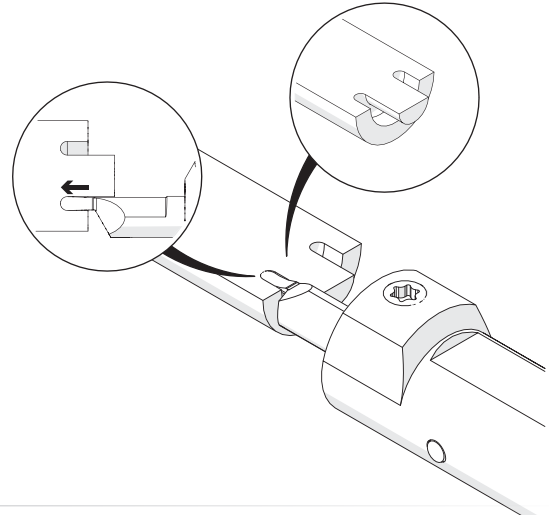
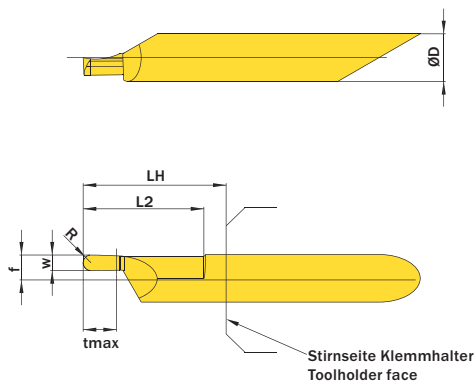


Abbildung zeigt / Drawing shows: A06.0200.15.02 AV R



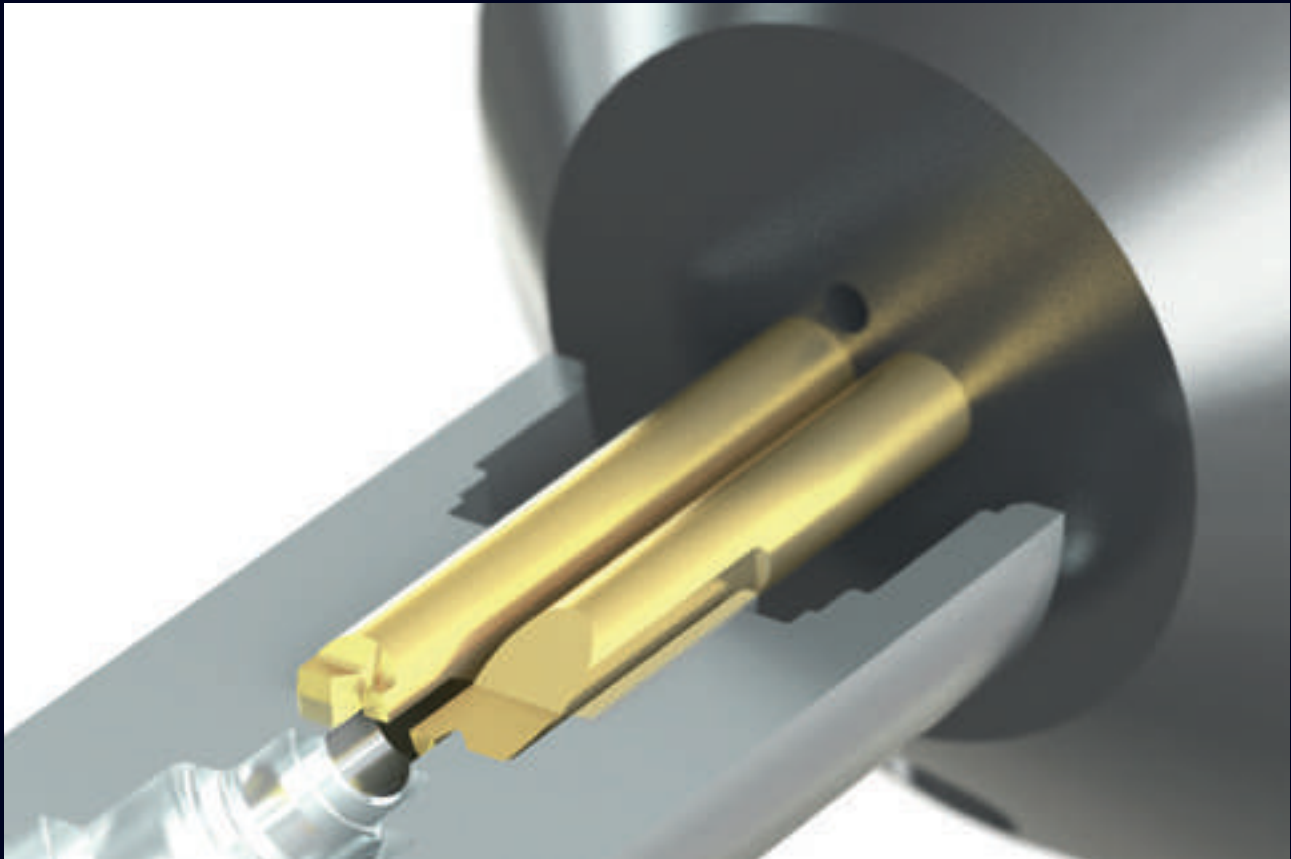
Mehr Informationen zur Kühlmittelzufuhr finden Sie auf Seite 22
Additional information about through coolant supply on page 22

ØD	w ^{+0,05}	L2	Kühlmittelzufuhr Through coolant supply	Artikelnummer Part number	Webcode www.simtek.com/webcode	Unsere erste Wahl Our first choice	ØDmin (Min. Bohrung) ØDmin (min. bore)	f	LH	R	tmax	Connectcode www.simtek.com/code
mm	mm	mm				P K M N S	mm	mm	mm	mm	mm	
6,0	1,0	15,2	+	A06.0100.15.02 AV R/L	R AJSD L AFPJ	X800 X400	6,2	2,95	18,0	0,5	2,0	R A06.L L A06.R
6,0	1,6	15,2	+	A06.0160.15.02 AV R/L	R ANSC L AF08	X800 X400	6,2	2,95	18,0	0,8	3,0	R A06.L L A06.R
6,0	2,0	15,2	+	A06.0200.15.02 AV R/L	R AMGH L ANFX	X800 X400	6,2	2,95	18,0	1,0	4,0	R A06.L L A06.R
6,0	2,5	15,2	+	A06.0250.15.02 AV R/L	R AHPW L ADH1	X800 X400	6,2	2,95	18,0	1,25	5,0	R A06.L L A06.R
6,0	3,0	15,2	+	A06.0300.15.02 AV R/L	R ABYF L ADZQ	X800 X400	6,2	2,95	18,0	1,5	6,0	R A06.L L A06.R

Bestellbeispiel // Order example: **A06.0100.15.02 AV R X800** (R = Rechte Ausführung // Right hand version, X800 = Schneidstoff // Grade)

Individualwerkzeuge // Customized tools

Kundenindividuelle Werkzeuglösungen Customer-specific tooling solutions



Bearbeitung der doppelten Kontur in einer engen Bohrung mit doppeltem Vorschub führt zu einer erheblichen Kostenersparnis.

Machining of the double contour in a narrow bore with double feed results in considerable cost savings.

SIMTEK Individualwerkzeuge bieten unzählige Vorteile! Neben unserem Anspruch, jeweils die qualitativ bestmögliche Werkzeuglösung für Ihre Anwendung anzubieten, ist es auch unser Bestreben Ihnen durch ein SIMTEK Individualwerkzeug den größtmöglichen wirtschaftlichen Nutzen zu liefern! Tausende, aktuell erfolgreich eingesetzte Individualwerkzeuge bestätigen dies!

Kontaktieren Sie uns und lassen auch Sie sich von den Vorteilen mit SIMTEK Individualwerkzeugen überzeugen!

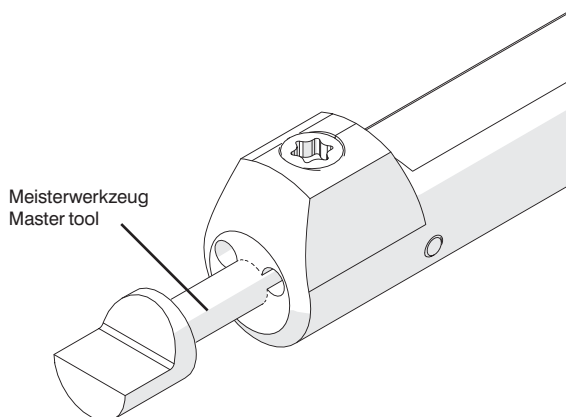
SIMTEK individual tools offer countless advantages! In addition to our goal to offer the qualitatively best possible tooling solution for your application, we also aspire to provide you with the greatest possible economic benefit from a customized SIMTEK tool! Thousands of currently successfully used SIMTEK individual tools confirm this!

Contact us and convince yourself of the advantages of SIMTEK individual tools!

Info

Hinweisliste
Additional information

MASTER



Zur korrekten Ausrichtung des Klemmhalters in Hydrodehnspannfuttern (o.ä.), bestellen Sie bitte die folgenden Meisterwerkzeuge, die im eingebauten Zustand ein korrektes und sicheres Ausrichten ermöglichen.

Please use the following Master tools, for adjusting and positioning the toolholder in hydraulic expansion chucks. These Master tools provide an easy and secure way.

Meisterwerkzeug Master tool	Webcode	Für Klemmhalter For toolholder
A04.MASTER GF25	ATWE	A04...
A05.MASTER GF25	ATWF	A05...
A06.MASTER GF25	ATWG	A06...
A07.MASTER GF25	ATWH	A07...
A08.MASTER GF25	AVJJ	A08...
A10.MASTER GF25	AVJH	A10...

T01

Bei den simturn Teilprofil-Gewindeschneidplatten für metrische ISO-Gewinde handelt es sich um Mehrbereichswerkzeuge, d.h. dass mit einem Werkzeug unterschiedliche Steigungen gefertigt werden können.

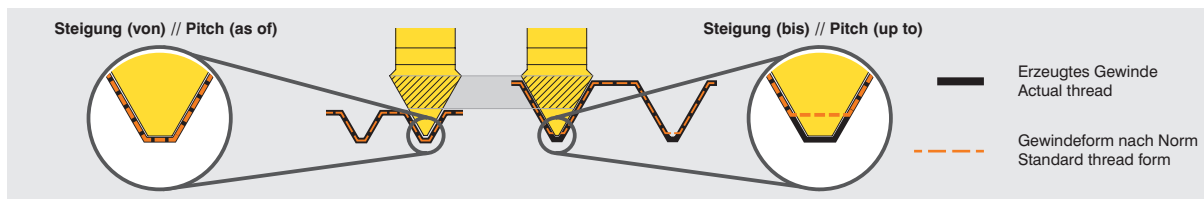
Das Schneidwerkzeug ist dabei immer auf die angegebene „Steigung (von)“ ausgelegt, wodurch ein normgerechtes Gewinde beim Fertigen dieser Steigung entsteht.

Die ebenfalls angegebene „Steigung (bis)“ kann mit diesem Werkzeug ebenfalls gefertigt werden. Es entsteht hierbei jedoch ein - gegenüber der Norm - geringfügig tieferes Gewinde. Die geringfügig höhere Gewindetiefe ist i.d.R. akzeptabel, es muss jedoch immer der Einzelfall beurteilt werden.

The simturn threading inserts with partial profile for metric ISO-threads are multi-purpose tools. This means that each insert is offering the possibility to machine different pitches.

The insert is always designed to meet the pitch given as „Pitch (as of)“: Machining this pitch will result in a standard conform thread form.

The given „Pitch (up to)“ can be machined too with this insert at the expense of standard conformity: The resulting thread will be slightly deeper than the standard. The deeper thread is usually acceptable, but the application and use needs to be evaluated.



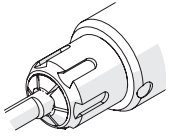
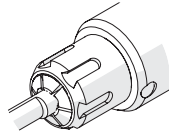
Beispiel // Example

Info

Hinweisliste
Additional information

T02

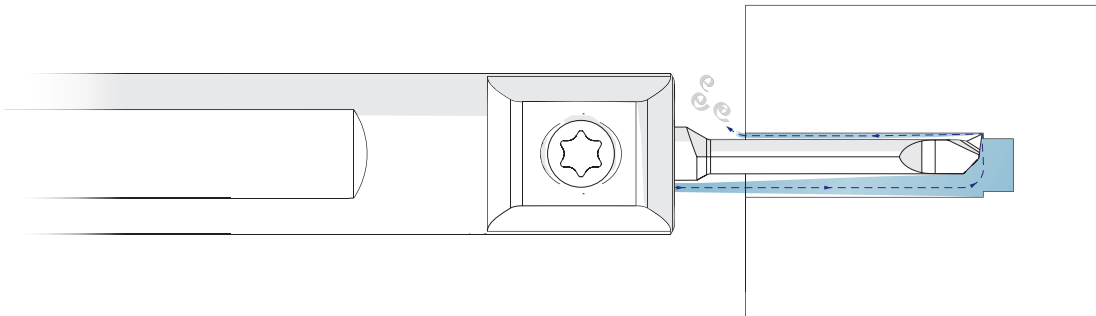
Alternative Mutter // Alternative screw nut

A04... ME ST T
A05... STA00.K.93.12.12
Ø D1 = 12,0 mm // 0,4724"A06... ME ST T
A07... STA00.K.113.15.14
Ø D1 = 14,0 mm // 0,5512"

Alternative Muttern für optimale Leistung bei beengten Platzverhältnissen in Bohrungen.

Alternative screw nuts for optimized performance when space in bores is restricted.

Hinweis / Hint





Generell empfehlen wir zur Kühlung die Kombination rechtes Werkzeug/rechte Kühlung bzw. linkes Werkzeug/linke Kühlung. Beim Ausdrehen einer Sacklochbohrung empfiehlt es sich jedoch diese zu hinterspülen, um die Späne aus der Bohrung zu führen (s. Abbildung). Viele unserer simturn AX – Trägerwerkzeuge bieten die Möglichkeit, vier verschiedene Kühlmittelzufuhrarten individuell einzustellen. Nutzen Sie diesen Vorteil und stimmen Sie die Kühlmittelzufuhr optimal auf Ihre Anwendung ab.

We generally recommend the combination right handed cutting tool and right handed coolant supply respectively left handed cutting tool and left handed coolant supply. However, for the boring of a blind hole it is preferable to supply the coolant along the back side of the insert in order to achieve controlled chip clearance (see image). Many of our simturn AX – toolholders offer the possibility to individually adjust four different types of coolant supply. Take advantage of this benefit and adjust the coolant supply in an optimum way for each of your application.

Legende

Legend

- SP**
CBN Schneidwerkzeug aus CBN // CBN insert // Outils coupants en CBN // Insetto CBN // Insetto CBN // CBN kesici uç
- SP**
HM Schneidwerkzeug aus Hartmetall // Carbide insert // Outils coupants en carbure de tungstène // Insetto in metallo duro
Insetto de carburo // Karbür kesici uç
- TW**
HM Trägerwerkzeug aus Hartmetall // Carbide toolholder // Porte-outils en carbure // Porta inserto in metallo duro
Porta-herramientas de carburo // Karbür tutucu
- TW**
ST Trägerwerkzeug aus Stahl // Steel toolholder // Porte-outils en acier // Porta inserto in acciaio
Porta-herramientas de acero // Çelik tutucu
- ME** ME-Spannprinzip // ME-clamping system // ME-système de fixation // Sistema di fissaggio - ME
Principio de sujeción ME // ME sıkma sistemli
- R** Rechts wie gezeichnet // Right hand version shown, left hand version inversely // A droite comme présenté // In figura utensile destro
Modelo derecho // Sağ model
-  Innere Kühlmittelzufuhr // Through coolant // Refroidissement interne // Lubrificazione interna
Con refrigeración interna // İçten soğutmalı
-  Schwingungsgedämpft // Anti-vibration // Anti vibration // Antivibrante // Anti-vibración // Anti vibrasyon

Index

simturn AX Produktverzeichnis
simturn AX Product List

Artikelnr. // Part Nr.	S/P	Artikelnr. // Part Nr.	S/P	Artikelnr. // Part Nr.	S/P	Artikelnr. // Part Nr.	S/P	Artikelnr. // Part Nr.	S/P
A04.0.375.10 L	60	A04.0022	26	A04.0C15.15.32.15 YEL	85	A04.1807.09.17.10 YR	73	A04.1817.10.37.15 YL	76
A04.0.375.10 R	60	A04.0022 T	34	A04.0C15.15.32.15 YER	85	A04.1807.09.17.10 YUR	90	A04.1817.10.37.15 YR	76
A04.0.375.15 L	60	A04.0022.0140.A04	62	A04.0C17.10.37.15 YEL	85	A04.1807.12.17.10 YL	73	A04.1817.10.37.15 YUR	92
A04.0.375.15 R	60	A04.0022.0140.A06	62	A04.0C17.10.37.15 YER	85	A04.1807.12.17.10 YR	73	A04.1817.15.37.15 YL	76
A04.0.500	26	A04.0022.ME ST T	43	A04.0C17.15.37.15 YEL	85	A04.1808.09.19.10 YL	73	A04.1817.15.37.15 YR	76
A04.0.500 T	34	A04.0022.NC L	32	A04.0C17.15.37.15 YER	85	A04.1808.09.19.10 YR	73	A04.1817.15.37.15 YUL	92
A04.0.500.10 R	60	A04.0022.NC R	32	A04.0C17.20.37.15 YEL	85	A04.1808.09.19.10 YUR	90	A04.1817.15.37.15 YUR	92
A04.0.500.12.42.ME HMT	41	A04.0023	26	A04.0C17.20.37.15 YER	85	A04.1808.12.19.10 YL	73	A04.1817.20.37.05 YL	76
A04.0.500.15 L	60	A04.0023.ME ST T	43	A04.1.000	26	A04.1808.12.19.10 YR	73	A04.1817.20.37.05 YR	76
A04.0.500.15 R	60	A04.0025	26	A04.1.000 T	34	A04.1808.12.19.10 YUR	90	A04.1817.20.37.15 YL	76
A04.0.625.ME ST T	43	A04.0025 T	34	A04.1.000.ME ST T	43	A04.1808.13.19.10 YL	73	A04.1817.20.37.15 YR	76
A04.0.500.NC L	32	A04.0025.0140.A06	62	A04.1.000.S	57	A04.1808.13.19.10 YR	73	A04.1817.20.37.15 YUR	92
A04.0.500.NC R	32	A04.0025.ME ST T	43	A04.1010	57	A04.1810.06.22.05 YL	74	A04.1817.25.37.10 YL	76
A04.0.500.S	57	A04.0028	31	A04.1010.10 L	60	A04.1810.06.22.05 YR	74	A04.1817.25.37.10 YR	76
A04.0.625	26	A04.0028.0140.A06	62	A04.1010.10 R	60	A04.1810.06.22.10 YL	74	A04.1817.25.37.10 YUR	92
A04.0.625 T	34	A04.0050.06.20 GL	103	A04.1010.15 L	60	A04.1810.06.22.10 YR	74	A04.1817.25.37.15 YUR	92
A04.0.625.05 B ST	65	A04.0050.06.20 GR	103	A04.1010.15 R	60	A04.1810.06.22.10 YUR	90	A04.1820.10.42.03 YL	77
A04.0.625.ME ST T	43	A04.0050.09.20 GL	103	A04.1212	57	A04.1810.09.22.05 YL	74	A04.1820.10.42.03 YR	77
A04.0.625.NC L	32	A04.0050.09.20 GR	103	A04.1212.10 L	60	A04.1810.09.22.05 YR	74	A04.1820.10.42.05 YL	77
A04.0.625.NC R	32	A04.0050.12.20 GL	103	A04.1212.10 R	60	A04.1810.09.22.10 YL	74	A04.1820.10.42.05 YR	77
A04.0.625.S	57	A04.0050.12.20 GR	103	A04.1212.15 L	60	A04.1810.09.22.10 YR	74	A04.1820.10.42.15 YL	77
A04.0.750	26	A04.0070.08.30 GL	103	A04.1212.15 R	60	A04.1810.09.22.10 YUL	90	A04.1820.10.42.15 YR	77
A04.0.750 T	34	A04.0070.08.30 GR	103	A04.1212.G.080 L	56	A04.1810.09.22.10 YUR	90	A04.1820.10.42.15 YUL	92
A04.0.750.0140.A06	62	A04.0070.12.30 GL	103	A04.1212.G.080 R	56	A04.1810.13.22.10 YL	74	A04.1820.10.42.15 YUR	92
A04.0.750.ME ST T	43	A04.0070.12.30 GR	103	A04.1616	57	A04.1810.13.22.10 YR	74	A04.1820.15.42.03 YL	77
A04.0.750.NC L	32	A04.0070.16.30 GL	103	A04.1616.15 L	60	A04.1810.13.22.10 YUR	90	A04.1820.15.42.03 YR	77
A04.0.750.NC R	32	A04.0070.16.30 GR	103	A04.1616.15 R	60	A04.1812.10.27.03 YL	74	A04.1820.15.42.05 YL	77
A04.0.750.S	57	A04.0078.10.42 GL	103	A04.1616.G.100 L	56	A04.1812.10.27.03 YR	74	A04.1820.15.42.05 YR	77
A04.0010	26	A04.0078.10.42 GR	103	A04.1616.G.100 R	56	A04.1812.10.27.05 YL	74	A04.1820.15.42.15 YL	77
A04.0010 L	33	A04.0078.15.42 GL	103	A04.1804.04.10.05 YL	72	A04.1812.10.27.05 YR	74	A04.1820.15.42.15 YR	77
A04.0010 R	33	A04.0078.15.42 GR	103	A04.1804.04.10.05 YR	72	A04.1812.10.27.15 YL	74	A04.1820.15.42.15 YUL	92
A04.0010 T	33	A04.0078.20.42 GL	103	A04.1804.04.10.10 YL	72	A04.1812.10.27.15 YR	74	A04.1820.15.42.15 YUR	92
A04.0010.NC L	32	A04.0078.20.42 GR	103	A04.1804.04.10.10 YR	72	A04.1812.10.27.15 YUL	91	A04.1820.20.42.03 YL	77
A04.0010.NC R	32	A04.0078.25.42 GL	103	A04.1804.04.10.10 YUR	89	A04.1812.10.27.15 YUR	91	A04.1820.20.42.03 YR	77
A04.0012	26	A04.0078.25.42 GR	103	A04.1804.06.10.05 YL	72	A04.1812.15.27.05 YL	74	A04.1820.20.42.05 YL	77
A04.0012 T	34	A04.00C3.00.ME T	50	A04.1804.06.10.05 YR	72	A04.1812.15.27.05 YR	74	A04.1820.20.42.05 YR	77
A04.0012.10.42.ME H M L	40	A04.00C3.05	63	A04.1804.06.10.10 YL	72	A04.1812.15.27.15 YL	74	A04.1820.20.42.15 YL	77
A04.0012.10.42.ME H M R	40	A04.00C4.00.ME T	50	A04.1804.06.10.10 YR	72	A04.1812.15.27.15 YR	74	A04.1820.20.42.15 YR	77
A04.0012.12.42.ME H M T	41	A04.00C4.05	63	A04.1804.06.10.10 YUR	89	A04.1812.15.27.15 YUL	91	A04.1820.20.42.15 YUL	92
A04.0012.ME ST T	43	A04.00C5.06	63	A04.1804.08.10.10 YL	72	A04.1812.15.27.15 YUR	91	A04.1820.20.42.15 YUR	92
A04.0012.NC L	32	A04.0100.10.37 PL	116	A04.1804.08.10.10 YR	72	A04.1814.15.30.15 YUR	91	A04.1820.25.42.05 YL	77
A04.0012.NC R	32	A04.0100.10.37 PR	116	A04.1804.08.10.10 YUR	89	A04.1814.20.30.15 YL	75	A04.1820.25.42.05 YR	77
A04.0016	26	A04.0100.10.42 GL	103	A04.1805.04.12.10 YL	72	A04.1814.20.30.15 YR	75	A04.1820.25.42.15 YL	77
A04.0016 T	34	A04.0100.10.42 GR	103	A04.1805.04.12.10 YR	72	A04.1814.20.30.15 YUR	91	A04.1820.25.42.15 YR	77
A04.0016.05 B ST	65	A04.0100.15.37 PL	116	A04.1805.04.12.10 YUR	89	A04.1814.25.30.05 YL	75	A04.1820.25.42.15 YUL	92
A04.0016.06 B ST	65	A04.0100.15.37 PR	116	A04.1805.07.12.10 YL	72	A04.1814.25.30.05 YR	75	A04.1820.25.42.15 YUR	92
A04.0016.ME ST T	43	A04.0100.15.42 GL	103	A04.1805.07.12.10 YR	72	A04.1815.10.32.03 YL	75	A04.1820.30.42.05 YL	77
A04.0016.NC L	32	A04.0100.15.42 GR	103	A04.1805.07.12.10 YUR	89	A04.1815.10.32.03 YR	75	A04.1820.30.42.05 YR	77
A04.0016.NC R	32	A04.0100.15.42 VL	114	A04.1805.09.12.10 YL	72	A04.1815.10.32.05 YL	75	A04.1820.35.42.05 YR	77
A04.0020	26	A04.0100.15.42 VR	114	A04.1805.09.12.10 YR	72	A04.1815.10.32.05 YR	75	A04.1C04.04.10.05 YL	72
A04.0020 T	34	A04.0100.20.42 GL	103	A04.1805.09.12.10 YUR	89	A04.1815.10.32.15 YL	75	A04.1C04.04.10.05 YR	72
A04.0020.0140.A04	62	A04.0100.20.42 GR	103	A04.1806.06.14.10 YL	72	A04.1815.10.32.15 YR	75	A04.1C04.04.10.10 YL	72
A04.0020.0140.A05	62	A04.0100.20.42 PL	116	A04.1806.06.14.10 YR	72	A04.1815.10.32.15 YUL	91	A04.1C04.04.10.10 YR	72
A04.0020.0140.A06	62	A04.0100.20.42 PR	116	A04.1806.06.14.10 YUR	89	A04.1815.10.32.15 YUR	91	A04.1C04.04.10.10 YUR	89
A04.0020.10.42.15 YEL	85	A04.0117.15.42 VL	114	A04.1806.10.14.10 YL	72	A04.1815.15.32.05 YL	75	A04.1C04.04.10.10 YUL	89
A04.0020.10.42.15 YER	85	A04.0117.15.42 VR	114	A04.1806.10.14.10 YR	72	A04.1815.15.32.05 YR	75	A04.1C04.06.10.05 YL	72
A04.0020.15.42.15 YEL	85	A04.0808.10 L	60	A04.1806.10.14.10 YUR	89	A04.1815.15.32.15 YL	75	A04.1C04.06.10.05 YR	72
A04.0020.15.42.15 YER	85	A04.0808.10 R	60	A04.1807.06.17.05 YL	73	A04.1815.15.32.15 YR	75	A04.1C04.06.10.10 YL	72
A04.0020.15.42.40 YER	85	A04.0808.15 L	60	A04.1807.06.17.05 YR	73	A04.1815.15.32.15 YUL	91	A04.1C04.06.10.10 YR	72
A04.0020.20.42.15 YEL	85	A04.0808.15 R	60	A04.1807.06.17.10 YL	73	A04.1815.15.32.15 YUR	91	A04.1C04.06.10.10 YUL	89
A04.0020.20.42.15 YER	85	A04.0C12.10.27.15 YEL	85	A04.1807.06.17.10 YR	73	A04.1815.20.32.05 YL	75	A04.1C04.06.10.10 YUR	89
A04.0020.25.42.15 YEL	85	A04.0C12.10.27.15 YER	85	A04.1807.06.17.10 YUL	90	A04.1815.20.32.05 YR	75	A04.1C04.08.10.10 YL	72
A04.0020.25.42.15 YER	85	A04.0C12.15.27.15 YEL	85	A04.1807.06.17.10 YUR	90	A04.1815.20.32.15 YL	75	A04.1C04.08.10.10 YR	72
A04.0020.ME ST T	43	A04.0C12.15.27.15 YER	85	A04.1807.09.17.05 YL	73	A04.1815.20.32.15 YR	75	A04.1C04.08.10.10 YUL	89
A04.0020.NC L	32	A04.0C15.10.32.15 YEL	85	A04.1807.09.17.05 YR	73	A04.1815.20.32.15 YUL	91	A04.1C04.08.10.10 YUR	89
A04.0020.NC R	32	A04.0C15.10.32.15 YER	85	A04.1807.09.17.10 YL	73	A04.1815.20.32.15 YUR	91	A04.1C05.04.12.10 YL	72

Index

simturn AX Produktverzeichnis
simturn AX Product List

Artikelnr.// Part Nr.	S/P	Artikelnr.// Part Nr.	S/P	Artikelnr.// Part Nr.	S/P	Artikelnr.// Part Nr.	S/P	Artikelnr.// Part Nr.	S/P
A04.1C05.04.12.10 YUL	89	A04.1C12.10.27.15 YUR	91	A04.2012.10.27.15 YR	94	A04.4720.20.42.15 YR	97	A04.M025.01.02.07 MR	117
A04.1C05.04.12.10 YUR	89	A04.1C12.15.27.05 YL	74	A04.2012.15.27.15 YL	94	A04.5015.01.03.00 YL	71	A04.M035.01.04.12 ML	117
A04.1C05.07.12.10 YL	72	A04.1C12.15.27.05 YR	74	A04.2012.15.27.15 YR	94	A04.5015.01.03.00 YR	71	A04.M035.01.04.12 MR	117
A04.1C05.07.12.10 YR	72	A04.1C12.15.27.15 YL	74	A04.2015.10.32.15 YL	95	A04.5020.01.04.00 YL	71	A04.M040.01.05.15 ML	117
A04.1C05.07.12.10 YUL	89	A04.1C12.15.27.15 YR	74	A04.2015.10.32.15 YR	95	A04.5020.01.04.00 YR	71	A04.M040.01.05.15 MR	117
A04.1C05.07.12.10 YUR	89	A04.1C12.15.27.15 YUL	91	A04.2015.15.32.15 YL	95	A04.5025.02.05.00 YL	71	A04.M045.01.06.17 ML	117
A04.1C05.09.12.10 YL	72	A04.1C12.15.27.15 YUR	91	A04.2015.15.32.15 YR	95	A04.5025.02.05.00 YR	71	A04.M045.01.06.17 MR	117
A04.1C05.09.12.10 YR	72	A04.1C12.20.27.15 YR	74	A04.2015.20.32.15 YL	95	A04.5030.02.06.00 YL	71	A04.M050.01.07.24 ML	117
A04.1C05.09.12.10 YUL	89	A04.1C14.15.30.15 YL	75	A04.2015.20.32.15 YR	95	A04.5030.02.06.00 YR	71	A04.M050.01.07.24 MR	117
A04.1C05.09.12.10 YUR	89	A04.1C14.15.30.15 YR	75	A04.2020	57	A04.5035.03.07.00 YL	71	A04.M070.01.10.32 ML	117
A04.1C06.06.14.10 YL	72	A04.1C14.15.30.15 YUL	91	A04.2020.10.42.15 YL	95	A04.5035.03.07.00 YR	71	A04.M070.01.10.32 MR	117
A04.1C06.06.14.10 YR	72	A04.1C14.15.30.15 YUR	91	A04.2020.10.42.15 YR	95	A04.5040.04.08.00 YL	71	A04.M070.01.15.32 ML	117
A04.1C06.06.14.10 YUL	89	A04.1C14.20.30.15 YL	75	A04.2020.10.42.15 YR	92	A04.5040.04.08.00 YR	71	A04.M070.01.15.32 MR	117
A04.1C06.06.14.10 YUR	89	A04.1C14.20.30.15 YR	75	A04.2020.10.42.15 YUR	92	A04.5045.05.09.00 YL	71	A04.MT05.01.15.42 ML	118
A04.1C06.10.14.10 YL	72	A04.1C14.20.30.15 YUL	91	A04.2020.15.42.15 YL	95	A04.5045.05.09.00 YR	71	A04.MT05.01.15.42 MR	118
A04.1C06.10.14.10 YR	72	A04.1C14.20.30.15 YUR	91	A04.2020.15.42.15 YR	95	A04.56.0050.13.00 AG R	127	A04.MT05.02.15.42 ML	119
A04.1C06.10.14.10 YUL	89	A04.1C14.25.30.05 YL	75	A04.2020.20.42.15 YL	95	A04.5C15.01.03.00 YL	71	A04.MT05.02.15.42 MR	119
A04.1C06.10.14.10 YUR	89	A04.1C14.25.30.05 YR	75	A04.2020.20.42.15 YR	95	A04.5C15.01.03.00 YR	71	A04.MT07.02.15.32 ML	119
A04.1C07.06.17.05 YL	73	A04.1C15.10.32.03 YL	75	A04.2020.25.42.15 YL	95	A04.5C20.01.04.00 YL	71	A04.MT07.02.15.32 MR	119
A04.1C07.06.17.05 YR	73	A04.1C15.10.32.03 YR	75	A04.2020.25.42.15 YR	95	A04.5C20.01.04.00 YR	71	A04.MT07.02.15.42 ML	119
A04.1C07.06.17.10 YL	73	A04.1C15.10.32.05 YL	75	A04.2525	57	A04.5C25.02.05.00 YL	71	A04.MT07.02.15.42 MR	119
A04.1C07.06.17.10 YR	73	A04.1C15.10.32.05 YR	75	A04.2C04.04.10.10 YL	94	A04.5C25.02.05.00 YR	71	A04.MT08.01.15.39 ML	118
A04.1C07.06.17.10 YUL	90	A04.1C15.10.32.15 YL	75	A04.2C04.04.10.10 YR	94	A04.5C30.02.06.00 YL	71	A04.MT08.01.15.39 MR	118
A04.1C07.06.17.10 YUR	90	A04.1C15.10.32.15 YR	75	A04.2C04.06.10.10 YL	94	A04.5C30.02.06.00 YR	71	A04.MT08.02.15.39 ML	119
A04.1C07.09.17.05 YL	73	A04.1C15.10.32.15 YUL	91	A04.2C04.06.10.10 YR	94	A04.5C35.03.07.00 YL	71	A04.MT08.02.15.39 MR	119
A04.1C07.09.17.05 YR	73	A04.1C15.10.32.15 YUR	91	A04.2C07.06.17.10 YL	94	A04.5C35.03.07.00 YR	71	A04.ST22	66
A04.1C07.09.17.10 YL	73	A04.1C15.15.32.05 YL	75	A04.2C07.06.17.10 YR	94	A04.5C40.04.08.00 YL	71	A04.ST22 T	67
A04.1C07.09.17.10 YR	73	A04.1C15.15.32.05 YR	75	A04.2C07.09.17.10 YL	94	A04.5C40.04.08.00 YR	71	A04.ST22.A T	69
A04.1C07.09.17.10 YUL	90	A04.1C15.15.32.15 YL	75	A04.2C07.09.17.10 YR	94	A04.5C45.05.09.00 YL	71	A04.UN24.02.15.42 ML	123
A04.1C07.09.17.10 YUR	90	A04.1C15.15.32.15 YR	75	A04.2C10.06.22.10 YL	94	A04.5C45.05.09.00 YR	71	A04.UN24.02.15.42 MR	123
A04.1C07.12.17.10 YL	73	A04.1C15.15.32.15 YUL	91	A04.2C10.06.22.10 YR	94	A04.5H20.30.42.05 YS R	84	A04.UN28.02.15.39 ML	123
A04.1C07.12.17.10 YR	73	A04.1C15.15.32.15 YUR	91	A04.2C10.09.22.10 YL	94	A04.8704.04.10.05 YS R	83	A04.UN28.02.15.39 MR	123
A04.1C08.09.19.10 YL	73	A04.1C15.20.32.05 YL	75	A04.2C10.09.22.10 YR	94	A04.8705.06.12.05 YS R	83	A04.UN32.01.15.42 ML	122
A04.1C08.09.19.10 YR	73	A04.1C15.20.32.05 YR	75	A04.2C12.10.27.15 YL	94	A04.8706.06.14.05 YS R	83	A04.UN32.01.15.42 MR	122
A04.1C08.09.19.10 YUL	90	A04.1C15.20.32.15 YL	75	A04.2C12.10.27.15 YR	94	A04.8707.06.17.05 YS R	83	A04.UN32.02.15.39 ML	123
A04.1C08.09.19.10 YUR	90	A04.1C15.20.32.15 YR	75	A04.2C12.15.27.15 YL	94	A04.8707.06.17.10 YS R	83	A04.UN32.02.15.39 MR	123
A04.1C08.12.19.10 YL	73	A04.1C15.20.32.15 YUL	91	A04.2C12.15.27.15 YR	94	A04.8710.09.22.05 YS R	83	A04.VD16.B.MET	53
A04.1C08.12.19.10 YR	73	A04.1C15.20.32.15 YUR	91	A04.2C15.10.32.15 YL	95	A04.8712.10.27.05 YS R	83	A04.VD16.MET	51
A04.1C08.12.19.10 YUL	90	A04.1C15.25.32.15 YR	75	A04.2C15.10.32.15 YR	95	A04.8712.10.27.10 YS R	83	A04.VD20.B.MET	53
A04.1C08.12.19.10 YUR	90	A04.1C17.10.37.15 YL	76	A04.2C15.15.32.15 YL	95	A04.8712.15.27.05 YS R	83	A04.VD20.MET	51
A04.1C08.13.19.10 YL	73	A04.1C17.10.37.15 YR	76	A04.2C15.15.32.15 YR	95	A04.8715.10.32.05 YS R	83	A04.VD25.B.MET	53
A04.1C08.13.19.10 YR	73	A04.1C17.10.37.15 YUL	92	A04.2C15.20.32.15 YL	95	A04.8715.10.32.10 YS R	83	A04.VD25.MET	51
A04.1C10.06.22.05 YL	74	A04.1C17.10.37.15 YUR	92	A04.2C15.20.32.15 YR	95	A04.8715.15.32.05 YS R	83	A04.VD30.B.MET	53
A04.1C10.06.22.05 YR	74	A04.1C17.15.37.15 YL	76	A04.3015.15.32.10 YL	101	A04.8720.10.42.05 YS R	83	A04.VD30.MET	51
A04.1C10.06.22.10 YL	74	A04.1C17.15.37.15 YR	76	A04.3015.15.32.10 YR	101	A04.8720.15.42.05 YS R	83	A04.WF22.40 T	68
A04.1C10.06.22.10 YR	74	A04.1C17.15.37.15 YUL	92	A04.3015.20.32.10 YL	101	A04.8720.15.42.10 YS R	83	A05.0.375.20 L	61
A04.1C10.06.22.10 YUL	90	A04.1C17.15.37.15 YUR	92	A04.3015.20.32.10 YR	101	A04.9015.12.32.15 YL	98	A05.0.375.20 R	61
A04.1C10.06.22.10 YUR	90	A04.1C17.20.37.05 YL	76	A04.3020.15.42.15 YL	101	A04.9015.12.32.15 YR	98	A05.0.500	27
A04.1C10.09.22.05 YL	74	A04.1C17.20.37.05 YR	76	A04.3020.15.42.15 YR	101	A04.9020.15.42.15 YL	98	A05.0.500 T	35
A04.1C10.09.22.05 YR	74	A04.1C17.20.37.15 YL	76	A04.3020.25.42.15 YL	101	A04.9020.15.42.15 YR	98	A05.0.500.12.42.ME H M T	41
A04.1C10.09.22.10 YL	74	A04.1C17.20.37.15 YR	76	A04.3020.25.42.15 YR	101	A04.C050.06.20 GL	103	A05.0.500.20 L	61
A04.1C10.09.22.10 YR	74	A04.1C17.20.37.15 YUL	92	A04.3210.10.22.10 YL	96	A04.C050.06.20 GR	103	A05.0.500.20 R	61
A04.1C10.09.22.10 YUL	90	A04.1C17.20.37.15 YUR	92	A04.3212.15.27.10 YR	96	A04.C050.09.20 GL	103	A05.0.500.G.080 R	56
A04.1C10.09.22.10 YUR	90	A04.1C17.25.37.10 YL	76	A04.3215.15.32.10 YR	96	A04.C050.09.20 GR	103	A05.0.500.ME ST T	44
A04.1C10.13.22.10 YL	74	A04.1C17.25.37.10 YR	76	A04.3220.10.42.15 YR	96	A04.C050.12.20 GL	103	A05.0.500.S	57
A04.1C10.13.22.10 YR	74	A04.1C17.25.37.10 YUL	92	A04.3220.20.42.15 YR	96	A04.C050.12.20 GR	103	A05.0.625	27
A04.1C10.13.22.10 YUL	90	A04.1C17.25.37.10 YUR	92	A04.34.0050.13.00 AG R	127	A04.C070.08.30 GL	103	A05.0.625 T	35
A04.1C10.13.22.10 YUR	90	A04.1C17.25.37.15 YL	92	A04.45.0050.13.00 AG R	127	A04.C070.08.30 GR	103	A05.0.625.07 B ST	65
A04.1C10.15.22.10 YR	74	A04.1C17.25.37.15 YUR	92	A04.46.0100.13.00 AG R	127	A04.C070.12.30 GL	103	A05.0.625.20 L	61
A04.1C12.10.27.03 YL	74	A04.1C17.30.37.10 YR	76	A04.4710.10.22.10 YL	97	A04.C070.12.30 GR	103	A05.0.625.20 R	61
A04.1C12.10.27.03 YR	74	A04.1H20.30.42.07 YS R	84	A04.4710.10.22.10 YR	97	A04.C070.16.30 GL	103	A05.0.625.G.100 R	56
A04.1C12.10.27.05 YL	74	A04.2010.06.22.10 YL	94	A04.4712.15.27.10 YL	97	A04.C070.16.30 GR	103	A05.0.625.ME ST T	44
A04.1C12.10.27.05 YR	74	A04.2010.06.22.10 YR	94	A04.4712.15.27.10 YR	97	A04.DB19.15.40.15 YR	87	A05.0.625.S	57
A04.1C12.10.27.15 YL	74	A04.2010.09.22.10 YL	94	A04.4715.15.32.10 YL	97	A04.DB19.15.40.20 YR	87	A05.0.750	27
A04.1C12.10.27.15 YR	74	A04.2010.09.22.10 YR	94	A04.4715.15.32.10 YR	97	A04.DB19.20.40.20 YR	87	A05.0.750 T	35
A04.1C12.10.27.15 YUL	91	A04.2012.10.27.15 YL	94	A04.4720.20.42.15 YL	97	A04.M025.01.02.07 ML	117	A05.0.750.ME ST T	44

Index

simturn AX Produktverzeichnis
simturn AX Product List

Artikelnr. // Part Nr.	S/P	Artikelnr. // Part Nr.	S/P	Artikelnr. // Part Nr.	S/P	Artikelnr. // Part Nr.	S/P	Artikelnr. // Part Nr.	S/P
A05.0010	27	A05.0100.20.52 VR	114	A05.0200.10.52 GL	106	A05.1825.30.52.20 YR	79	A05.MT07.01.15.51 ML	118
A05.0010 L	33	A05.0100.25.52 GL	104	A05.0200.10.52 GR	106	A05.1825.30.52.20 YUL	93	A05.MT07.01.15.51 MR	118
A05.0010 R	33	A05.0100.25.52 GR	104	A05.0200.15.52 GL	106	A05.1825.30.52.20 YUR	93	A05.MT10.01.15.48 ML	118
A05.0010 T	33	A05.0100.25.52 PL	116	A05.0200.15.52 GR	106	A05.1825.35.49.20 YL	78	A05.MT10.01.15.48 MR	118
A05.0012	27	A05.0100.25.52 PR	116	A05.0200.20.52 GL	106	A05.1825.35.49.20 YR	78	A05.MT10.01.20.48 ML	118
A05.0012 T	35	A05.0100.30.52 GL	104	A05.0200.20.52 GR	106	A05.1825.35.52.20 YL	79	A05.MT10.01.20.48 MR	118
A05.0012.12.42.ME HMT	41	A05.0100.30.52 GR	104	A05.0200.20.52 VL	114	A05.1825.35.52.20 YR	79	A05.MT10.01.25.48 ML	118
A05.0012.ME ST T	44	A05.0100.30.52 PL	116	A05.0200.20.52 VR	114	A05.1825.40.49.20 YL	78	A05.MT10.01.25.48 MR	118
A05.0016	27	A05.0100.30.52 PR	116	A05.0200.25.52 GL	106	A05.1825.40.49.20 YR	78	A05.MT10.02.15.48 ML	119
A05.0016 T	35	A05.0100.35.52 GL	104	A05.0200.25.52 GR	106	A05.1825.40.52.20 YL	79	A05.MT10.02.15.48 MR	119
A05.0016.07 B ST	65	A05.0100.35.52 GR	104	A05.0200.30.52 GL	106	A05.1825.40.52.20 YR	79	A05.MT75.02.15.51 ML	119
A05.0016.08 B ST	65	A05.0117.10.52 GL	104	A05.0200.30.52 GR	106	A05.1825.40.52.20 YUL	93	A05.MT75.02.15.51 MR	119
A05.0016.ME ST T	44	A05.0117.10.52 GR	104	A05.0808.15 L	61	A05.1825.40.52.20 YUR	93	A05.SA16.01.25.52 MR	126
A05.0020	27	A05.0117.15.52 GL	104	A05.0808.15 R	61	A05.1H25.40.52.07 YS R	84	A05.ST22	66
A05.0020 T	35	A05.0117.15.52 GR	104	A05.1.000	27	A05.2020	57	A05.ST22 T	67
A05.0020.0140.A05	62	A05.0117.20.52 GL	104	A05.1.000 T	35	A05.2025.10.52.20 YL	95	A05.ST22.A T	69
A05.0020.0140.A06	62	A05.0117.20.52 GR	104	A05.1.000.ME ST T	44	A05.2025.10.52.20 YR	95	A05.UN20.02.15.52 ML	123
A05.0020.ME ST T	44	A05.0117.20.52 VL	114	A05.1.000.S	57	A05.2025.15.52.20 YL	95	A05.UN20.02.15.52 MR	123
A05.0022	27	A05.0117.20.52 VR	114	A05.1010	57	A05.2025.15.52.20 YR	95	A05.UN24.01.15.52 ML	122
A05.0022 T	35	A05.0117.25.52 GL	104	A05.1010.20 L	61	A05.2025.20.52.20 YL	95	A05.UN24.01.15.52 MR	122
A05.0022.ME ST T	44	A05.0117.25.52 GR	104	A05.1010.20 R	61	A05.2025.20.52.20 YR	95	A05.UN32.01.15.52 ML	122
A05.0023	27	A05.0117.30.52 GL	104	A05.1212	57	A05.2025.25.52.20 YL	95	A05.UN32.01.15.52 MR	122
A05.0023.ME ST T	44	A05.0117.30.52 GR	104	A05.1212.20 L	61	A05.2025.25.52.20 YR	95	A05.VD16.B.ME T	53
A05.0025	27	A05.0117.35.52 GL	104	A05.1212.20 R	61	A05.2025.30.52.20 YL	95	A05.VD16.ME T	51
A05.0025 T	35	A05.0117.35.52 GR	104	A05.1212.G.080 L	56	A05.2025.30.52.20 YR	95	A05.VD20.B.ME T	53
A05.0025.10.52.20 YEL	85	A05.0150.10.52 GL	105	A05.1212.G.080 R	56	A05.2525	57	A05.VD20.ME T	51
A05.0025.10.52.20 YER	85	A05.0150.10.52 GR	105	A05.1616	57	A05.3025.20.52.20 YL	101	A05.VD25.B.ME T	53
A05.0025.10.52.40 YEL	85	A05.0150.15.52 GL	105	A05.1616.20 L	61	A05.3025.20.52.20 YR	101	A05.VD25.ME T	51
A05.0025.10.52.40 YER	85	A05.0150.15.52 GR	105	A05.1616.20 R	61	A05.3025.30.52.20 YL	101	A05.VD30.B.ME T	53
A05.0025.15.52.20 YEL	85	A05.0150.20.52 GL	105	A05.1616.G.100 L	56	A05.3025.30.52.20 YR	101	A05.VD30.ME T	51
A05.0025.15.52.20 YER	85	A05.0150.20.52 GR	105	A05.1616.G.100 R	56	A05.3225.15.52.15 YR	96	A05.WF22.40 T	68
A05.0025.20.52.20 YEL	85	A05.0150.20.52 VL	114	A05.1825.10.52.05 YL	79	A05.3225.25.52.15 YR	96	A06.0.375.20 L	61
A05.0025.20.52.20 YER	85	A05.0150.20.52 VR	114	A05.1825.10.52.05 YR	79	A05.3225.35.52.15 YR	96	A06.0.375.20 R	61
A05.0025.25.52.20 YEL	85	A05.0150.25.52 GL	105	A05.1825.10.52.20 YL	79	A05.4545.15.52 FL	99	A06.0.500	28
A05.0025.25.52.20 YER	85	A05.0150.25.52 GR	105	A05.1825.10.52.20 YR	79	A05.4545.15.52 FR	99	A06.0.500.25 L	61
A05.0025.30.52.20 YEL	85	A05.0150.30.52 GL	105	A05.1825.10.52.20 YUL	93	A05.4545.20.52 FL	99	A06.0.500.25 R	61
A05.0025.30.52.20 YER	85	A05.0150.30.52 GR	105	A05.1825.10.52.20 YUR	93	A05.4545.20.52 FR	99	A06.0.500.ME ST T	45
A05.0025.ME ST T	44	A05.0150.35.52 GL	105	A05.1825.15.52.03 YL	79	A05.4725.15.52.15 YL	97	A06.0.500.S	58
A05.0028	31	A05.0150.35.52 GR	105	A05.1825.15.52.03 YR	79	A05.4725.15.52.15 YR	97	A06.0.625	28
A05.0078.10.52 GL	104	A05.0157.10.52 GL	105	A05.1825.15.52.05 YL	79	A05.4725.25.52.15 YL	97	A06.0.625 T	36
A05.0078.10.52 GR	104	A05.0157.10.52 GR	105	A05.1825.15.52.05 YR	79	A05.4725.25.52.15 YR	97	A06.0.625.10 B ST	65
A05.0078.15.52 GL	104	A05.0157.15.52 GL	105	A05.1825.15.52.20 YL	79	A05.5H25.40.52.05 YS R	84	A06.0.625.25 L	61
A05.0078.15.52 GR	104	A05.0157.15.52 GR	105	A05.1825.15.52.20 YR	79	A05.8H25.15.52.05 YS R	84	A06.0.625.25 R	61
A05.0078.20.52 GL	104	A05.0157.20.52 GL	105	A05.1825.15.52.20 YUL	93	A05.8H25.20.52.05 YS R	84	A06.0.625.ME ST T	45
A05.0078.20.52 GR	104	A05.0157.20.52 GR	105	A05.1825.15.52.20 YUR	93	A05.8H25.20.52.10 YS R	84	A06.0.625.S	58
A05.0078.25.52 GL	104	A05.0157.20.52 VL	114	A05.1825.20.49.20 YL	78	A05.8H25.30.52.10 YS R	84	A06.0.750	28
A05.0078.25.52 GR	104	A05.0157.20.52 VR	114	A05.1825.20.49.20 YR	78	A05.9025.10.52.20 YL	98	A06.0.750 T	36
A05.0078.30.52 GL	104	A05.0157.25.52 GL	105	A05.1825.20.52.05 YL	79	A05.9025.10.52.20 YR	98	A06.0.750.ME ST T	45
A05.0078.30.52 GR	104	A05.0157.25.52 GR	105	A05.1825.20.52.05 YR	79	A05.9025.15.52.20 YL	98	A06.0.750.S	58
A05.0078.35.52 GL	104	A05.0157.30.52 GL	105	A05.1825.20.52.20 YL	79	A05.9025.15.52.20 YR	98	A06.0012	28
A05.0078.35.52 GR	104	A05.0157.30.52 GR	105	A05.1825.20.52.20 YR	79	A05.9025.20.52.20 YL	98	A06.0012 T	36
A05.00C3.00.ME T	50	A05.0163.20.52 VL	114	A05.1825.20.52.20 YUL	93	A05.9025.20.52.20 YR	98	A06.0012.ME ST T	45
A05.00C3.07	63	A05.0163.20.52 VR	114	A05.1825.20.52.20 YUR	93	A05.AC16.01.25.52 MR	125	A06.0016	28
A05.00C4.00.ME T	50	A05.0198.10.52 GL	105	A05.1825.25.49.20 YL	78	A05.BS24.02.15.52 ML	124	A06.0016 T	36
A05.00C5.08	63	A05.0198.10.52 GR	105	A05.1825.25.49.20 YR	78	A05.BS24.02.15.52 MR	124	A06.0016.10 B ST	65
A05.0100.10.52 GL	104	A05.0198.15.52 GL	105	A05.1825.25.52.20 YL	79	A05.BS26.02.15.52 ML	124	A06.0016.14.50.ME HMT	42
A05.0100.10.52 GR	104	A05.0198.15.52 GR	105	A05.1825.25.52.20 YR	79	A05.BS26.02.15.52 MR	124	A06.0016.ME ST T	45
A05.0100.15.52 GL	104	A05.0198.20.52 GL	105	A05.1825.25.52.20 YUL	93	A05.BS28.02.15.52 ML	124	A06.0020	28
A05.0100.15.52 GR	104	A05.0198.20.52 GR	105	A05.1825.25.52.20 YUR	93	A05.BS28.02.15.52 MR	124	A06.0020 T	36
A05.0100.15.52 PL	116	A05.0198.20.52 VL	114	A05.1825.30.49.05 YL	78	A05.DB24.15.50.20 YR	87	A06.0020.0140.A06	62
A05.0100.15.52 PR	116	A05.0198.20.52 VR	114	A05.1825.30.49.05 YR	78	A05.DB24.20.50.20 YR	87	A06.0020.ME ST T	45
A05.0100.20.52 GL	104	A05.0198.25.52 GL	105	A05.1825.30.49.20 YL	78	A05.DB24.25.50.20 YR	87	A06.0022	28
A05.0100.20.52 GR	104	A05.0198.25.52 GR	105	A05.1825.30.49.20 YR	78	A05.MT05.01.15.52 ML	118	A06.0022 T	36
A05.0100.20.52 PL	116	A05.0198.30.52 GL	105	A05.1825.30.52.05 YL	79	A05.MT05.01.15.52 MR	118	A06.0022.0140.A06	62
A05.0100.20.52 PR	116	A05.0198.30.52 GR	105	A05.1825.30.52.05 YR	79	A05.MT05.02.15.52 ML	119	A06.0022.ME ST T	45
A05.0100.20.52 VL	114	A05.0198.30.52.10 GR	105	A05.1825.30.52.20 YL	79	A05.MT05.02.15.52 MR	119	A06.0023	28

Index

simturn AX Produktverzeichnis
simturn AX Product List

Artikelnr.// Part Nr.	S/P	Artikelnr.// Part Nr.	S/P	Artikelnr.// Part Nr.	S/P	Artikelnr.// Part Nr.	S/P	Artikelnr.// Part Nr.	S/P
A06.0025	28	A06.0100.30.62 GL	107	A06.0157.25.62 VL	114	A06.0250.15.02 AV L	135	A06.2030.40.62.20 YL	95
A06.0025 T	36	A06.0100.30.62 GR	107	A06.0157.25.62 VR	114	A06.0250.15.02 AV R	135	A06.2030.40.62.20 YR	95
A06.0025.MESTT	45	A06.0100.30.62 PL	116	A06.0157.30.62 GL	108	A06.0300.15.01 AG L	128	A06.2525	58
A06.0028	31	A06.0100.30.62 PR	116	A06.0157.30.62 GR	108	A06.0300.15.01 AG R	128	A06.3030.20.62.20 YL	101
A06.0030.15.62.20 YEL	86	A06.0100.35.62 GL	107	A06.0157.35.62 GL	108	A06.0300.15.01 AV L	134	A06.3030.20.62.20 YR	101
A06.0030.15.62.20 YER	86	A06.0100.35.62 GR	107	A06.0157.35.62 GR	108	A06.0300.15.01 AV R	134	A06.3030.30.62.20 YL	101
A06.0030.17.20 AF L	100	A06.0100.40.62 GL	107	A06.0157.40.62 GL	108	A06.0300.15.02 AG L	129	A06.3030.30.62.20 YR	101
A06.0030.17.20 AF R	100	A06.0100.40.62 GR	107	A06.0157.40.62 GR	108	A06.0300.15.02 AG R	129	A06.3230.20.62.15 YR	96
A06.0030.20.62.20 YEL	86	A06.0100.40.62 PL	116	A06.0160.15.01 AV L	134	A06.0300.15.02 AV L	135	A06.3230.30.62.15 YR	96
A06.0030.20.62.20 YER	86	A06.0100.40.62 PR	116	A06.0160.15.01 AV R	134	A06.0300.15.02 AV R	135	A06.3230.40.62.15 YR	96
A06.0030.25.62.20 YEL	86	A06.0117.10.62 GL	107	A06.0160.15.02 AV L	135	A06.0318.15.01 AG R	128	A06.4545.20.62 FL	99
A06.0030.25.62.20 YER	86	A06.0117.10.62 GR	107	A06.0160.15.02 AV R	135	A06.0318.15.01 AG L	128	A06.4545.20.62 FR	99
A06.0030.30.62.20 YEL	86	A06.0117.10.62.10 GR	107	A06.0163.25.62 VL	114	A06.0318.15.02 AG L	129	A06.4545.25.62 FL	99
A06.0030.30.62.20 YER	86	A06.0117.15.01 AG L	128	A06.0163.25.62 VR	114	A06.0318.15.02 AG R	129	A06.4545.25.62 FR	99
A06.0030.40.62.20 YEL	86	A06.0117.15.01 AG R	128	A06.0198.10.62 GL	109	A06.1.000	28	A06.4730.20.62.15 YL	97
A06.0030.40.62.20 YER	86	A06.0117.15.02 AG L	129	A06.0198.10.62 GR	109	A06.1.000 T	36	A06.4730.20.62.15 YR	97
A06.0045.11.20 AF L	100	A06.0117.15.02 AG R	129	A06.0198.15.01 AG L	128	A06.1.000.MESTT	45	A06.4730.30.62.15 YL	97
A06.0045.11.20 AF R	100	A06.0117.15.62 GL	107	A06.0198.15.01 AG R	128	A06.1.000.S	58	A06.4730.30.62.15 YR	97
A06.0060.05.20 AF L	100	A06.0117.15.62 GR	107	A06.0198.15.02 AG L	129	A06.1010.25 L	61	A06.5H30.45.62.05 YS R	84
A06.0060.05.20 AF R	100	A06.0117.20.62 GL	107	A06.0198.15.02 AG R	129	A06.1010.25 R	61	A06.5H30.15.62.15 YS R	84
A06.0078.10.62 GL	106	A06.0117.20.62 GR	107	A06.0198.15.62 GL	109	A06.1212	58	A06.5H30.20.62.15 YS R	84
A06.0078.10.62 GR	106	A06.0117.25.62 GL	107	A06.0198.15.62 GR	109	A06.1212.25 L	61	A06.AC14.01.25.62 MR	125
A06.0078.15.01.05 AG L	128	A06.0117.25.62 GR	107	A06.0198.20.62 GL	109	A06.1212.25 R	61	A06.BS19.02.15.62 ML	124
A06.0078.15.01.05 AG R	128	A06.0117.25.62 VL	114	A06.0198.20.62 GR	109	A06.1212.G.080 L	56	A06.BS19.02.15.62 MR	124
A06.0078.15.02.05 AG L	129	A06.0117.25.62 VR	114	A06.0198.25.62 GL	109	A06.1212.G.080 R	56	A06.BS20.02.15.62 ML	124
A06.0078.15.02.05 AG R	129	A06.0117.30.62 GL	107	A06.0198.25.62 GR	109	A06.1616	58	A06.BS20.02.15.62 MR	124
A06.0078.15.62 GL	106	A06.0117.30.62 GR	107	A06.0198.25.62 VL	114	A06.1616.25 L	61	A06.BS22.02.15.62 ML	124
A06.0078.15.62 GR	106	A06.0117.35.62 GL	107	A06.0198.25.62 VR	114	A06.1616.25 R	61	A06.BS22.02.15.62 MR	124
A06.0078.20.62 GL	106	A06.0117.35.62 GR	107	A06.0198.30.62 GL	109	A06.1616.G.100 L	56	A06.BS24.02.15.62 ML	124
A06.0078.20.62 GR	106	A06.0117.40.62 GL	107	A06.0198.30.62 GR	109	A06.1616.G.100 R	56	A06.BS24.02.15.62 MR	124
A06.0078.25.62 GL	106	A06.0117.40.62 GR	107	A06.0198.30.62.10 GR	109	A06.1830.15.62.20 YL	81	A06.BS26.02.15.62 ML	124
A06.0078.25.62 GR	106	A06.0150.10.62 GL	108	A06.0198.35.62 GL	109	A06.1830.15.62.20 YR	81	A06.BS26.02.15.62 MR	124
A06.0078.30.62 GL	106	A06.0150.10.62 GR	108	A06.0198.35.62 GR	109	A06.1830.15.62.20 YUL	93	A06.BS28.02.15.62 ML	124
A06.0078.30.62 GR	106	A06.0150.15.01 AG L	128	A06.0200.10.62 GL	109	A06.1830.15.62.20 YUR	93	A06.BS28.02.15.62 MR	124
A06.0078.35.62 GL	106	A06.0150.15.01 AG R	128	A06.0200.10.62 GR	109	A06.1830.20.62.05 YL	81	A06.DB29.15.60.20 YR	87
A06.0078.35.62 GR	106	A06.0150.15.01.05 AG L	128	A06.0200.15.01 AG L	128	A06.1830.20.62.05 YR	81	A06.DB29.20.60.20 YR	87
A06.00C3.00.MET	50	A06.0150.15.01.05 AG R	128	A06.0200.15.01 AG R	128	A06.1830.20.62.20 YL	81	A06.DB29.25.60.20 YR	87
A06.00C3.08	64	A06.0150.15.02 AG L	129	A06.0200.15.01 AV L	134	A06.1830.20.62.20 YR	81	A06.DB29.30.60.20 YR	87
A06.00C3.10	64	A06.0150.15.02 AG R	129	A06.0200.15.01 AV R	134	A06.1830.20.62.20 YUL	93	A06.MT10.01.15.62 ML	118
A06.00C4.00.MET	50	A06.0150.15.02.05 AG L	129	A06.0200.15.02 AG L	129	A06.1830.20.62.20 YUR	93	A06.MT10.01.15.62 MR	118
A06.00C4.08	64	A06.0150.15.02.05 AG R	129	A06.0200.15.02 AG R	129	A06.1830.25.62.20 YL	81	A06.MT10.02.15.62 ML	119
A06.00C4.10	64	A06.0150.15.62 GL	108	A06.0200.15.02 AV L	135	A06.1830.25.62.20 YR	81	A06.MT10.02.15.62 MR	119
A06.00C5.10	64	A06.0150.15.62 GR	108	A06.0200.15.02 AV R	135	A06.1830.25.62.20 YUL	93	A06.MT10.02.25.62 MR	119
A06.00C6.10	64	A06.0150.20.62 GL	108	A06.0200.15.62 GL	109	A06.1830.25.62.20 YUR	93	A06.MT12.01.15.62 ML	118
A06.0100.10.62 GL	107	A06.0150.20.62 GR	108	A06.0200.15.62 GR	109	A06.1830.30.62.05 YL	81	A06.MT12.01.15.62 MR	118
A06.0100.10.62 GR	107	A06.0150.25.62 GL	108	A06.0200.20.62 GL	109	A06.1830.30.62.05 YR	81	A06.MT12.01.20.62 ML	118
A06.0100.15.01 AG L	128	A06.0150.25.62 GR	108	A06.0200.20.62 GR	109	A06.1830.30.62.20 YL	81	A06.MT12.01.20.62 MR	118
A06.0100.15.01 AG R	128	A06.0150.25.62 VL	114	A06.0200.20.62 VL	114	A06.1830.30.62.20 YR	81	A06.MT12.01.25.62 ML	118
A06.0100.15.01 AV L	134	A06.0150.25.62 VR	114	A06.0200.20.62 VR	114	A06.1830.30.62.20 YUL	93	A06.MT12.01.25.62 MR	118
A06.0100.15.01 AV R	134	A06.0150.30.62 GL	108	A06.0200.25.62 GL	109	A06.1830.30.62.20 YUR	93	A06.MT12.02.15.62 ML	119
A06.0100.15.01.05 AG L	128	A06.0150.30.62 GR	108	A06.0200.25.62 GR	109	A06.1830.35.59.20 YL	80	A06.MT12.02.15.62 MR	119
A06.0100.15.01.05 AG R	128	A06.0150.35.62 GL	108	A06.0200.25.62 VL	114	A06.1830.35.59.20 YR	80	A06.MT12.02.25.62 MR	119
A06.0100.15.02 AG L	129	A06.0150.35.62 GR	108	A06.0200.25.62 VR	114	A06.1830.35.62.20 YL	81	A06.MT15.01.15.62 ML	118
A06.0100.15.02 AG R	129	A06.0157.10.62 GL	108	A06.0200.30.62 GL	109	A06.1830.35.62.20 YR	81	A06.MT15.01.15.62 MR	118
A06.0100.15.02 AV L	135	A06.0157.10.62 GR	108	A06.0200.30.62 GR	109	A06.1830.35.62.20 YUL	93	A06.MT15.01.20.62 ML	118
A06.0100.15.02 AV R	135	A06.0157.15.01 AG L	128	A06.0239.15.01 AG L	128	A06.1830.35.62.20 YUR	93	A06.MT15.01.20.62 MR	118
A06.0100.15.02.05 AG L	129	A06.0157.15.01 AG R	128	A06.0239.15.01 AG R	128	A06.1830.40.59.20 YL	80	A06.MT15.01.25.62 ML	118
A06.0100.15.02.05 AG R	129	A06.0157.15.01 AV R	134	A06.0239.15.01 AV R	134	A06.1830.40.59.20 YR	80	A06.MT15.01.25.62 MR	118
A06.0100.15.62 GL	107	A06.0157.15.02 AG L	129	A06.0239.15.02 AG L	129	A06.1830.40.62.20 YL	81	A06.MT15.02.15.62 ML	119
A06.0100.15.62 GR	107	A06.0157.15.02 AG R	129	A06.0239.15.02 AG R	129	A06.1830.40.62.20 YR	81	A06.MT15.02.15.62 MR	119
A06.0100.20.62 GL	107	A06.0157.15.62 GL	108	A06.0250.15.01 AG L	128	A06.1830.40.62.20 YUL	93	A06.MT15.02.25.62 MR	119
A06.0100.20.62 GR	107	A06.0157.15.62 GR	108	A06.0250.15.01 AG R	128	A06.1830.40.62.20 YUR	93	A06.MT17.02.15.62 ML	119
A06.0100.25.62 GL	107	A06.0157.20.62 GL	108	A06.0250.15.01 AV L	134	A06.1830.45.59.20 YR	80	A06.MT17.02.15.62 MR	119
A06.0100.25.62 GR	107	A06.0157.20.62 GR	108	A06.0250.15.01 AV R	134	A06.1830.50.62.20 YL	81	A06.MT17.02.25.62 MR	119
A06.0100.25.62 VL	114	A06.0157.25.62 GL	108	A06.0250.15.02 AG L	129	A06.1830.50.62.20 YR	81	A06.MT20.02.15.62 ML	119
A06.0100.25.62 VR	114	A06.0157.25.62 GR	108	A06.0250.15.02 AG R	129	A06.2020	58	A06.MT20.02.15.62 MR	119

Index

simturn AX Produktverzeichnis
simturn AX Product List

Artikelnr. // Part Nr.	S/P	Artikelnr. // Part Nr.	S/P	Artikelnr. // Part Nr.	S/P	Artikelnr. // Part Nr.	S/P	Artikelnr. // Part Nr.	S/P
A06.NP18.01.15.62 ML	121	A07.0078.10.72 GR	109	A07.0150.40.72 GR	111	A07.1835.35.72.20 YR	81	A08.0.750.S	59
A06.NP18.01.15.62 MR	121	A07.0078.15.72 GL	109	A07.0157.10.72 GL	111	A07.1835.35.72.20 YUL	93	A08.0016	30
A06.NP27.01.15.62 ML	121	A07.0078.15.72 GR	109	A07.0157.10.72 GR	111	A07.1835.35.72.20 YUR	93	A08.0016 T	38
A06.NP27.01.15.62 MR	121	A07.0078.20.72 GL	109	A07.0157.15.72 GL	111	A07.1835.40.72.20 YL	81	A08.0016.ME IC	49
A06.SA14.01.25.62 MR	126	A07.0078.20.72 GR	109	A07.0157.15.72 GR	111	A07.1835.40.72.20 YR	81	A08.0016.ME ST T	47
A06.ST22	66	A07.0078.25.72 GL	109	A07.0157.20.72 GL	111	A07.1835.40.72.20 YUL	93	A08.0020	30
A06.ST22 T	67	A07.0078.25.72 GR	109	A07.0157.20.72 GR	111	A07.1835.40.72.20 YUR	93	A08.0020 T	38
A06.ST22.AT	69	A07.0078.30.72 GL	109	A07.0157.25.72 GL	111	A07.1835.45.72.20 YL	81	A08.0020.ME IC	49
A06.TR15.01.20.62 ML	120	A07.0078.30.72 GR	109	A07.0157.25.72 GR	111	A07.1835.45.72.20 YR	81	A08.0020.ME ST T	47
A06.TR15.01.20.62 MR	120	A07.0078.35.72 GL	109	A07.0157.30.72 GL	111	A07.1835.50.72.20 YL	81	A08.0022 T	38
A06.TR20.01.20.62 ML	120	A07.0078.35.72 GR	109	A07.0157.30.72 GR	111	A07.1835.50.72.20 YR	81	A08.0022.ME IC	49
A06.TR20.01.20.62 MR	120	A07.0078.40.72 GL	109	A07.0157.30.72 VL	115	A07.1835.50.72.20 YUL	93	A08.0025	30
A06.UN14.02.15.62 ML	123	A07.0078.40.72 GR	109	A07.0157.30.72 VR	115	A07.1835.50.72.20 YUR	93	A08.0025 T	38
A06.UN14.02.15.62 MR	123	A07.00C3.09	64	A07.0157.35.72 GL	111	A07.1835.60.72.20 YR	81	A08.0025.ME IC	49
A06.UN16.01.15.62 ML	122	A07.00C3.13	64	A07.0157.35.72 GR	111	A07.1H35.55.72.07 YS R	84	A08.0025.ME ST T	47
A06.UN16.01.15.62 MR	122	A07.00C4.09	64	A07.0157.40.72 GL	111	A07.2020	58	A08.0200.10.00 AG L	130
A06.UN16.02.15.62 ML	123	A07.00C4.13	64	A07.0157.40.72 GR	111	A07.2035.50.72.20 YL	95	A08.0200.10.00 AG R	130
A06.UN16.02.15.62 MR	123	A07.00C5.13	64	A07.0157.40.72 VR	115	A07.2035.50.72.20 YR	95	A08.0200.10.00 TAG L	131
A06.UN18.02.15.62 ML	123	A07.00C6.13	64	A07.0198.10.72 GL	112	A07.2525	58	A08.0200.10.00 TAG R	131
A06.UN18.02.15.62 MR	123	A07.0100.10.72 GL	110	A07.0198.10.72 GR	112	A07.3035.20.72.20 YL	101	A08.0200.15.00 AG L	130
A06.UN24.01.15.62 ML	122	A07.0100.10.72 GR	110	A07.0198.15.72 GL	112	A07.3035.20.72.20 YR	101	A08.0200.15.00 AG R	130
A06.UN24.01.15.62 MR	122	A07.0100.15.72 GL	110	A07.0198.15.72 GR	112	A07.3035.30.72.20 YL	101	A08.0200.15.00 TAG L	131
A06.VD16.B.MET	53	A07.0100.15.72 GR	110	A07.0198.20.72 GL	112	A07.3035.30.72.20 YR	101	A08.0200.15.00 TAG R	131
A06.VD16.MET	51	A07.0100.20.72 GL	110	A07.0198.20.72 GR	112	A07.4545.20.72 FL	99	A08.0250.10.00 AG L	130
A06.VD20.B.MET	53	A07.0100.20.72 GR	110	A07.0198.25.72 GL	112	A07.4545.20.72 FR	99	A08.0250.10.00 AG R	130
A06.VD20.MET	51	A07.0100.25.72 GL	110	A07.0198.25.72 GR	112	A07.4545.40.72 FL	99	A08.0250.10.00 TAG L	131
A06.VD25.B.MET	53	A07.0100.25.72 GR	110	A07.0198.30.72 GL	112	A07.4545.40.72 FR	99	A08.0250.10.00 TAG R	131
A06.VD25.MET	51	A07.0100.30.72 GL	110	A07.0198.30.72 GR	112	A07.4735.40.72.20 YL	97	A08.0250.15.00 AG L	130
A06.VD30.B.MET	53	A07.0100.30.72 GR	110	A07.0198.30.72 VL	115	A07.4735.40.72.20 YR	97	A08.0250.15.00 AG R	130
A06.VD30.MET	51	A07.0100.30.72 VL	115	A07.0198.30.72 VR	115	A07.5H35.55.72.05 YS R	84	A08.0250.15.00 TAG L	131
A06.WF22.40 T	68	A07.0100.30.72 VR	115	A07.0198.35.72 GL	112	A07.AC10.01.30.72 MR	125	A08.0250.15.00 TAG R	131
A07.0.625	29	A07.0100.35.72 GL	110	A07.0198.35.72 GR	112	A07.AC12.01.30.72 MR	125	A08.0300.10.00 AG L	130
A07.0.625 T	37	A07.0100.35.72 GR	110	A07.0200.10.72 GL	112	A07.DB34.20.70.20 YR	87	A08.0300.10.00 AG R	130
A07.0.625.13 B ST	65	A07.0100.40.72 GL	110	A07.0200.10.72 GR	112	A07.DB34.25.70.20 YR	87	A08.0300.10.00 TAG L	131
A07.0.625.ME ST T	46	A07.0100.40.72 GR	110	A07.0200.15.72 GL	112	A07.DB34.30.70.20 YR	87	A08.0300.10.00 TAG R	131
A07.0.625.S	58	A07.0117.10.72 GL	110	A07.0200.15.72 GR	112	A07.SA10.01.30.72 MR	126	A08.0300.15.00 AG L	130
A07.0.750	29	A07.0117.10.72 GR	110	A07.0200.20.72 GL	112	A07.SA12.01.30.72 MR	126	A08.0300.15.00 AG R	130
A07.0.750 T	37	A07.0117.15.72 GL	110	A07.0200.20.72 GR	112	A07.ST22	66	A08.0300.15.00 TAG L	131
A07.0.750.ME ST T	46	A07.0117.15.72 GR	110	A07.0200.25.72 GL	112	A07.ST22 T	67	A08.0300.15.00 TAG R	131
A07.0.750.S	58	A07.0117.20.72 GL	110	A07.0200.25.72 GR	112	A07.ST22.AT	69	A08.0400.10.00 AG L	130
A07.0016	29	A07.0117.20.72 GR	110	A07.0200.30.72 GL	112	A07.TR20.01.20.72 ML	120	A08.0400.10.00 AG R	130
A07.0016 T	37	A07.0117.25.72 GL	110	A07.0200.30.72 GR	112	A07.TR20.01.20.72 MR	120	A08.0400.10.00 TAG L	131
A07.0016.13 B ST	65	A07.0117.25.72 GR	110	A07.0200.30.72 VL	115	A07.TR20.01.30.72 ML	120	A08.0400.10.00 TAG R	131
A07.0016.14.50.ME HMT	42	A07.0117.30.72 GL	110	A07.0200.30.72 VR	115	A07.TR20.01.30.72 MR	120	A08.0400.15.00 AG L	130
A07.0016.ME ST T	46	A07.0117.30.72 GR	110	A07.0200.35.72 GL	112	A07.TR30.01.20.72 ML	120	A08.0400.15.00 AG R	130
A07.0020	29	A07.0117.30.72 VL	115	A07.0200.35.72 GR	112	A07.TR30.01.20.72 MR	120	A08.0400.15.00 TAG L	131
A07.0020 T	37	A07.0117.30.72 VR	115	A07.1.000	29	A07.TR30.01.30.72 ML	120	A08.0400.15.00 TAG R	131
A07.0020.ME ST T	46	A07.0117.35.72 GL	110	A07.1.000 T	37	A07.TR30.01.30.72 MR	120	A08.1.000	30
A07.0022	29	A07.0117.35.72 GR	110	A07.1.000.ME ST T	46	A07.VD16.B.MET	54	A08.1.000 T	38
A07.0022 T	37	A07.0117.40.72 GL	110	A07.1.000.S	58	A07.VD16.MET	52	A08.1.000.ME IC	49
A07.0022.ME ST T	46	A07.0117.40.72 GR	110	A07.1212.G.080 L	56	A07.VD20.B.MET	54	A08.1.000.ME ST T	47
A07.0023	29	A07.0150.10.72 GL	111	A07.1212.G.080 R	56	A07.VD20.MET	52	A08.1.000.S	59
A07.0023.ME ST T	46	A07.0150.10.72 GR	111	A07.1616	58	A07.VD25.B.MET	54	A08.1616	59
A07.0025	29	A07.0150.15.72 GL	111	A07.1616.25 L	61	A07.VD25.MET	52	A08.2020	59
A07.0025 T	37	A07.0150.15.72 GR	111	A07.1616.25 R	61	A07.VD30.B.MET	54	A08.2525	59
A07.0025.ME ST T	46	A07.0150.20.72 GL	111	A07.1616.G.100 L	56	A07.VD30.MET	52	A08.DB39.20.80.20 YR	87
A07.0028	31	A07.0150.20.72 GR	111	A07.1616.G.100 R	56	A07.WF22.40 T	68	A08.DB39.25.80.20 YR	87
A07.0035.25.72.20 YEL	86	A07.0150.25.72 GL	111	A07.1835.25.72.20 YL	81	A08.0.625	30	A08.DB39.30.80.20 YR	87
A07.0035.25.72.20 YER	86	A07.0150.25.72 GR	111	A07.1835.25.72.20 YR	81	A08.0.625 T	38	A08.ST22 T	67
A07.0035.30.72.20 YEL	86	A07.0150.30.72 GL	111	A07.1835.25.72.20 YUL	93	A08.0.625.ME IC	49	A08.ST22.AT	69
A07.0035.30.72.20 YER	86	A07.0150.30.72 GR	111	A07.1835.25.72.20 YUR	93	A08.0.625.ME ST T	47	A08.VD16.B.MET	54
A07.0035.35.72.20 YEL	86	A07.0150.30.72 VL	115	A07.1835.30.72.20 YL	81	A08.0.625.S	59	A08.VD16.MET	52
A07.0035.35.72.20 YER	86	A07.0150.30.72 VR	115	A07.1835.30.72.20 YR	81	A08.0.750	30	A08.VD20.B.MET	54
A07.0035.40.72.20 YEL	86	A07.0150.35.72 GL	111	A07.1835.30.72.20 YUL	93	A08.0.750 T	38	A08.VD20.MET	52
A07.0035.40.72.20 YER	86	A07.0150.35.72 GR	111	A07.1835.30.72.20 YUR	93	A08.0.750.ME IC	49	A08.VD25.B.MET	54
A07.0078.10.72 GL	109	A07.0150.40.72 GL	111	A07.1835.35.72.20 YL	81	A08.0.750.ME ST T	47	A08.VD25.MET	52

Index

simturn AX Produktverzeichnis
simturn AX Product List

Artikelnr. // Part Nr.	S/P	Artikelnr. // Part Nr.	S/P
A08.VD30.MET	52	A10.1.000.S	59
A08.WF22.40 T	68	A10.2020	59
A10.0.750	30	A10.2525	59
A10.0.750 T	39	A10.VD16.B.MET	54
A10.0.750.MESTT	48	A10.VD16.MET	52
A10.0.750.S	59	A10.VD20.B.MET	54
A10.0020	30	A10.VD20.MET	52
A10.0020 T	39	A10.VD25.B.MET	54
A10.0020.MESTT	48	A10.VD25.MET	52
A10.0022 T	39	A10.VD30.B.MET	54
A10.0025	30	A10.VD30.MET	52
A10.0025 T	39	A10.WF22.40 T	68
A10.0025.MESTT	48	TOG.K.A04.A1.MET	55
A10.0100.30.10 GL	113	TOG.K.A05.A1.MET	55
A10.0100.30.10 GR	113	TOG.K.A06.A1.MET	55
A10.0100.50.10 GL	113		
A10.0100.50.10 GR	113		
A10.0200.30.10 GL	113		
A10.0200.30.10 GR	113		
A10.0200.50.10 GL	113		
A10.0200.50.10 GR	113		
A10.0300.20.00 AG L	132		
A10.0300.20.00 AG R	132		
A10.0300.20.00 TAG L	133		
A10.0300.20.00 TAG R	133		
A10.0300.25.00 AG L	132		
A10.0300.25.00 AG R	132		
A10.0300.25.00 TAG L	133		
A10.0300.25.00 TAG R	133		
A10.0300.30.00 AG L	132		
A10.0300.30.00 AG R	132		
A10.0300.30.00 TAG L	133		
A10.0300.30.00 TAG R	133		
A10.0300.30.10 GL	113		
A10.0300.30.10 GR	113		
A10.0300.50.10 GL	113		
A10.0300.50.10 GR	113		
A10.0400.20.00 AG L	132		
A10.0400.20.00 AG R	132		
A10.0400.20.00 TAG L	133		
A10.0400.20.00 TAG R	133		
A10.0400.25.00 AG L	132		
A10.0400.25.00 AG R	132		
A10.0400.25.00 TAG L	133		
A10.0400.25.00 TAG R	133		
A10.0400.30.00 AG L	132		
A10.0400.30.00 AG R	132		
A10.0400.30.00 TAG L	133		
A10.0400.30.00 TAG R	133		
A10.0400.40.00 TAG L	133		
A10.0400.40.00 TAG R	133		
A10.0500.20.00 AG L	132		
A10.0500.20.00 AG R	132		
A10.0500.20.00 TAG L	133		
A10.0500.20.00 TAG R	133		
A10.0500.25.00 AG L	132		
A10.0500.25.00 AG R	132		
A10.0500.25.00 TAG L	133		
A10.0500.25.00 TAG R	133		
A10.0500.30.00 AG L	132		
A10.0500.30.00 AG R	132		
A10.0500.30.00 TAG L	133		
A10.0500.30.00 TAG R	133		
A10.1.000	30		
A10.1.000 T	39		
A10.1.000.MESTT	48		

Das Werkzeugsystem im Überblick
The Tool System Overview

Großartige **Leistung** in Bohrungen **ab Ø 7,0 mm.** Great **performance** in bores **as of Ø 7,0 mm.**

Auswahl der Anwendungen // Choice of Applications

Ausdrehen · Kopieren · Fasen · Rückwärtsdrehen · Nutenstechen · Vorstehen · Gewinden · Axialstechen
Boring · Copying · Chamfering · Back Boring · Grooving · Pre-Part-Off · Threading · Face Grooving

Übersicht aller Anwendungen ab Seite 150
Overview of all applications as of page 150

Hauptanwendungen // Main Applications

Ausdrehen Boring



Ausdrehen ab Bohrungsdurchmesser Ø 7,0 mm. Erhältlich sowohl mit spezieller Spantreppe zur optimierten Spanbildung als auch mit CBN-Schneidstoff für die Hartbearbeitung.

Boring applications as of bore diameter Ø 7,0 mm. Available with special chip former as well as with CBN-grades for hard part turning.

Nutenstechen Grooving



Große Auswahl an Werkzeugen für das allgemeine Nutenstechen sowie für das Stechen von Sicherungsringnuten. Viele verschiedene Werkzeuggrößen und unterschiedliche Schneidbreiten.

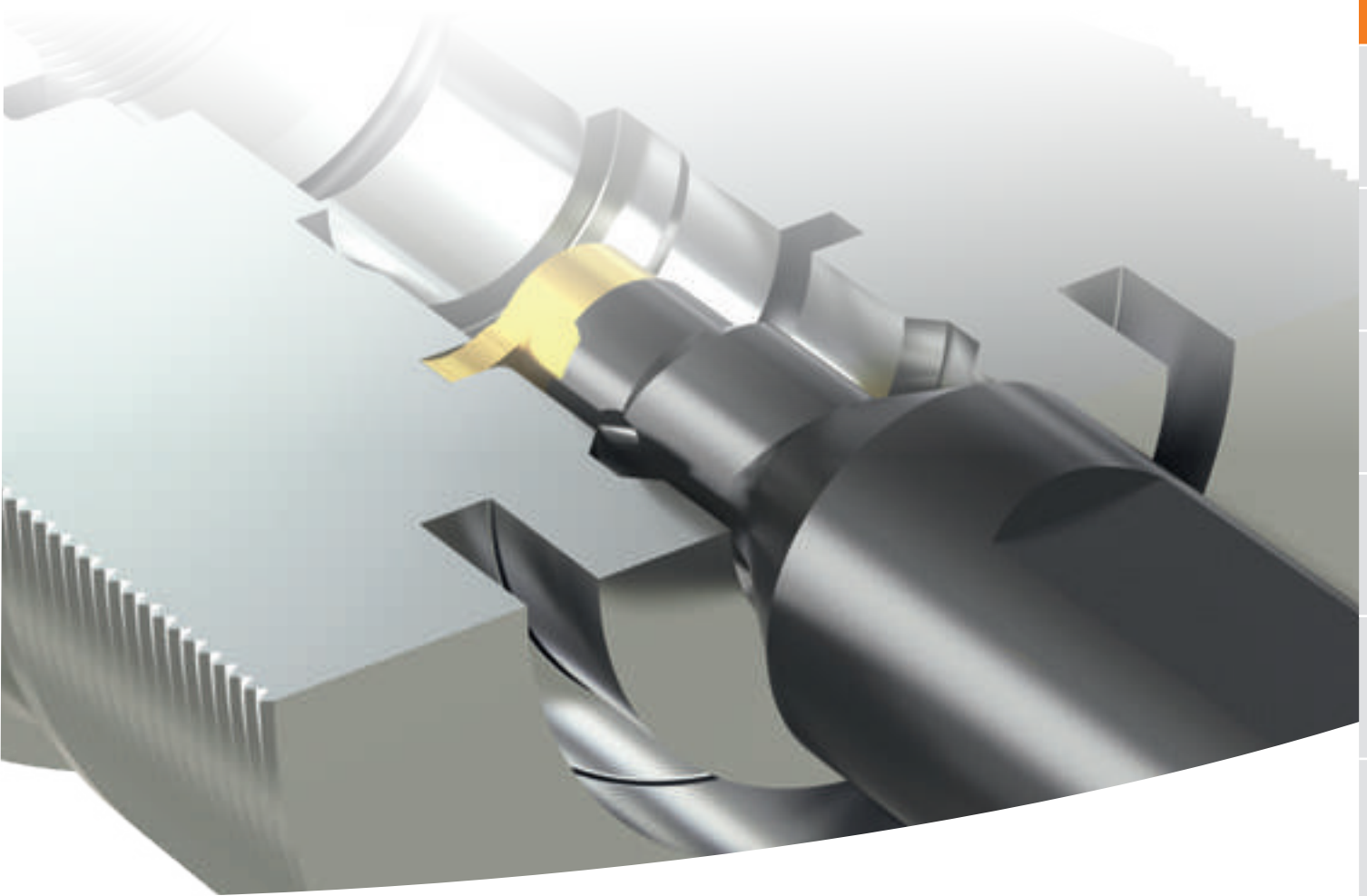
Wide range of tools for general grooving as well as for circlip ring grooving. Great variety in different tools sizes and cutting edge widths.

Kopieren Copying



Optimal ausgelegte Werkzeuge zum Kopieren und Profildrehen für Bohrungsdurchmesser zwischen Ø 7,0 mm und Ø 24,0 mm. In allen simturn DX Größen erhältlich.

Optimally designed tools for copying and profiling in bores between Ø 7,0 mm and Ø 24,0 mm. Available in all sizes of the system simturn DX.



Einstechen und Profildrehen Grooving and Profiling



Mit unseren Werkzeugen zum Einstechen und Profildrehen können Sie neben dem eigentlichen Einstechen zur Herstellung einer komplexen Nut deren Flanken mit dem gleichen Werkzeug Profildrehen.

Tools for grooving and profiling. Besides the machining of a complex groove, the groove flanks can be profiled with the same tool.

Gewinden Threading



simturn DX Schneidplatten zum Herstellen aller gängigen Gewindearten. Verschiedene Steigungen, Gänge und Größen verfügbar.

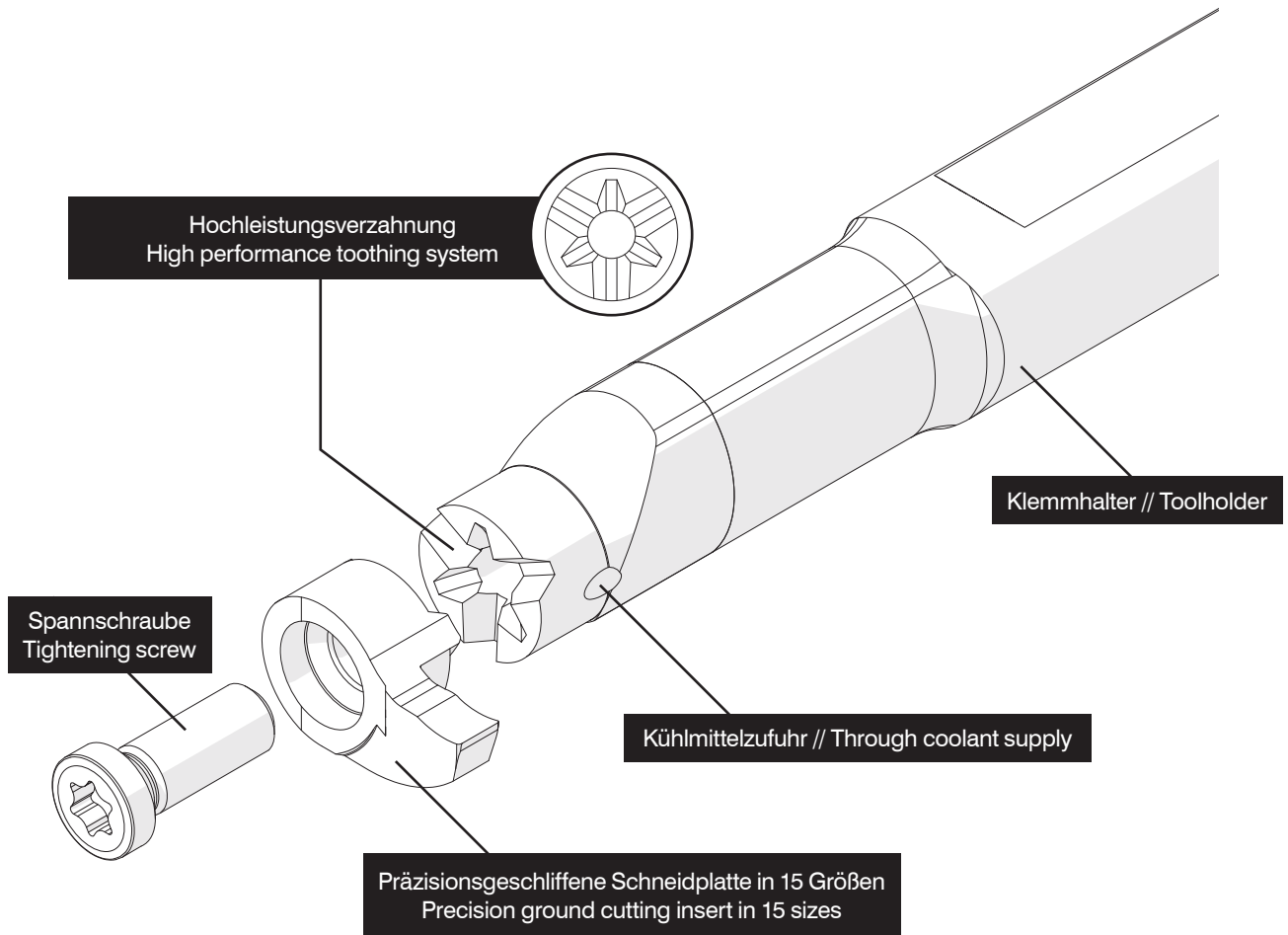
simturn DX inserts for the machining of all major internal thread types. Different pitches, threads/inch and sizes available.



Das System im Detail The System Details

Bitte beachten Sie die allgemeinen Gebrauchshinweise auf Seite
Please read the general instructions for use on page

433



Umfangreiches Sortiment an stirnseitig aufgeschraubten Hartmetall-Schneidplatten. Verfügbar in 15 verschiedenen Größen, für die optimale Bearbeitung von Bohrungen ab \varnothing 7,0 mm bis ca. \varnothing 24,0 mm.

Schwingungsgedämpfte Trägerwerkzeuge aus Hartmetall oder Stahl, für zahlreiche Anwendungen.




Mit rund 2.000 Standardwerkzeugen für nahezu jede Anwendung ein passendes Werkzeug verfügbar.


Wide range of carbide cutting inserts, fixed with a screw on the toolholder front side. Available in 15 different sizes, for best results in bores between \varnothing 7,0 mm and \varnothing 24,0 mm.




Anti-vibration carbide and steel toolholders are available for a variety of applications.


More than 2.000 standard items provide the right answer for almost every internal turning application.

Schneideinsatzgrößen im Vergleich Comparison of Cutting Insert Sizes

D07...07		D07...08		D08		D09...09	
							
Ø Dmin	tmax	Ø Dmin	tmax	Ø Dmin	tmax	Ø Dmin	tmax
mm	mm	mm	mm	mm	mm	mm	mm
7,0	1,0	7,8	2,0	7,8	1,0	9,0	1,8

D09...10		D10...10		D10...11		D11	
							
Ø Dmin	tmax	Ø Dmin	tmax	Ø Dmin	tmax	Ø Dmin	tmax
mm	mm	mm	mm	mm	mm	mm	mm
10,0	2,8	10,0	1,8	11,0	2,8	11,0	2,3

D10...12		D14		D16		D14...16	
							
Ø Dmin	tmax	Ø Dmin	tmax	Ø Dmin	tmax	Ø Dmin	tmax
mm	mm	mm	mm	mm	mm	mm	mm
12,0	3,4	14,0	4,0	16,0	4,3	16,0	5,5

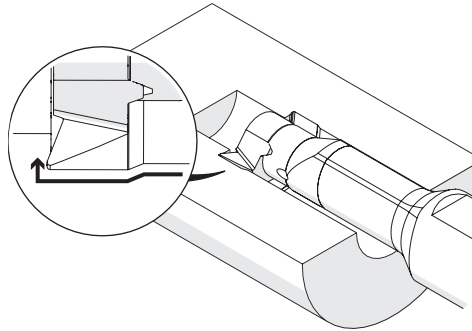
D14...17		D18...18		D18...20	
					
Ø Dmin	tmax	Ø Dmin	tmax	Ø Dmin	tmax
mm	mm	mm	mm	mm	mm
17,0	6,5	18,0	6,0	20,0	8,0

ØDmin Geeignet ab Bohrungsdurchmesser // Suitable as of bore diameter
tmax Mögliche Stechtiefe // Possible cutting depths

Standardanwendungen Standard Applications

Ab Seite
 As of page

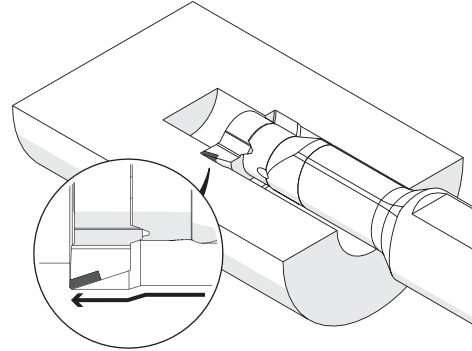
168



Ausdrehen
 Boring

Seite
 Page

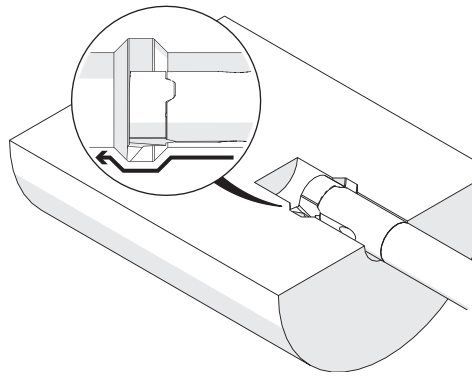
170



Ausdrehen, Hartbearbeitung
 Boring, Hard Part Turning

Seite
 Page

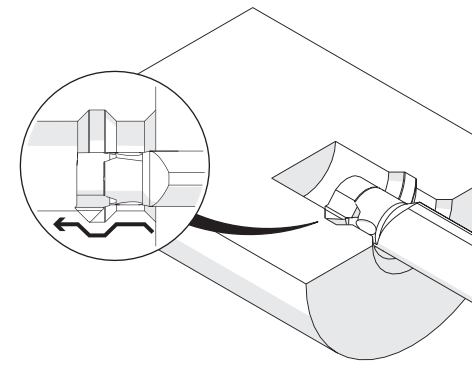
171



Kopieren und Profildrehen
 Copying and Profiling

Seite
 Page

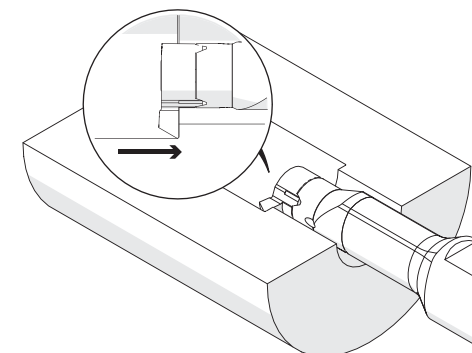
173



Ausdrehen und Fasen
 Boring and Chamfering

Seite
 Page

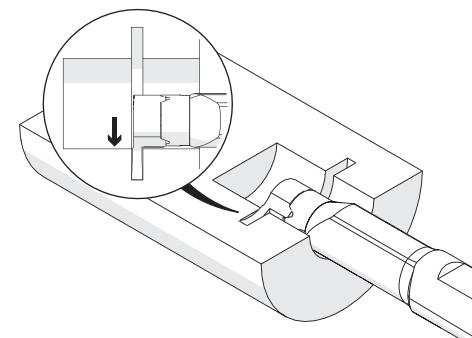
174



Rückwärtsdrehen
 Back Boring

Ab Seite
 As of page

175

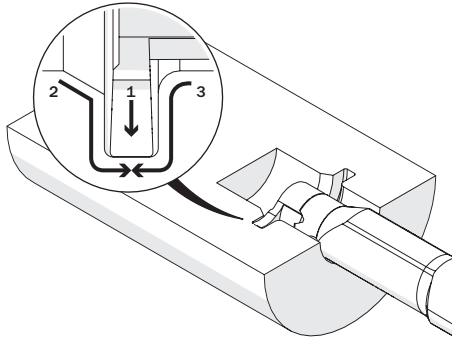


Nutenstechen
 Grooving

Standardanwendungen Standard Applications

Ab Seite
 As of page

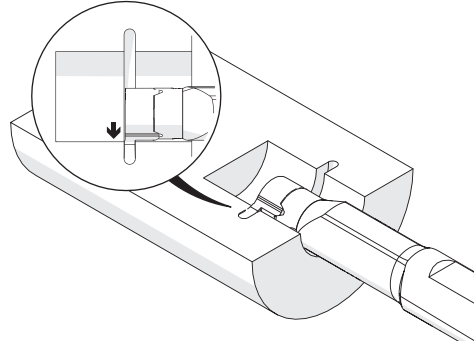
189



Einstecken und Profildrehen
 Grooving and Profiling

Ab Seite
 As of page

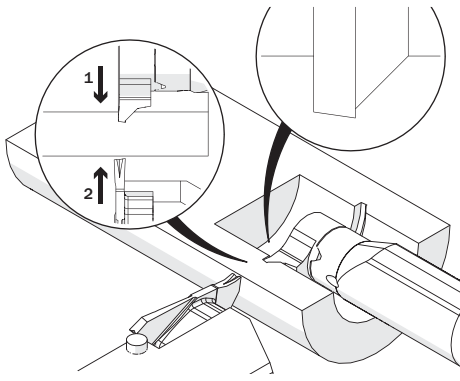
192



Stechen von Vollradiusnuten
 Full Radius Grooving

Seite
 Page

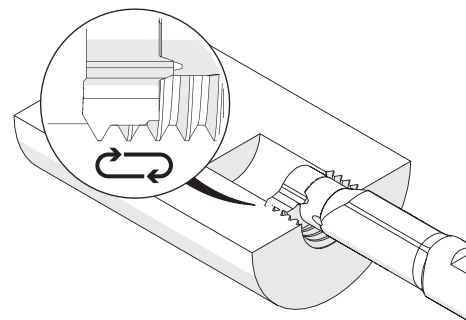
196



Vorstechen und Fasen
 Pre-Part-Off and Chamfering

Ab Seite
 As of page

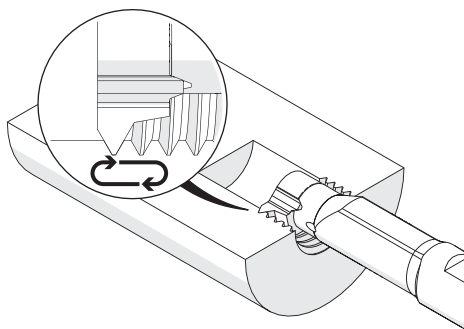
197



Gewinden: Metrisch ISO, Vollprofil
 Threading: Metric ISO, Full Profile

Ab Seite
 As of page

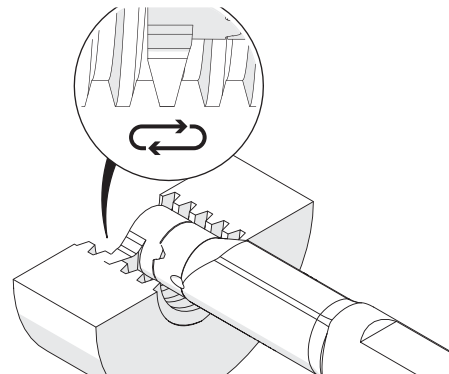
199



Gewinden: Metrisch ISO, Teilprofil
 Threading: Metric ISO, Partial Profile

Seite
 Page

201

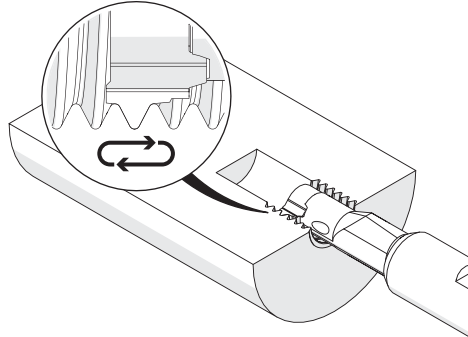


Gewinden: Trapezgewinde, Teilprofil
 Threading: Trapezoidal Thread, Partial Profile

Standardanwendungen Standard Applications

Seite
Page

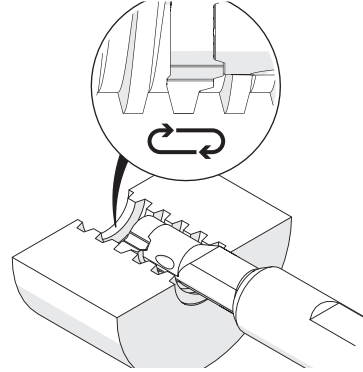
202



Gewinden: BSW / BSF, Vollprofil
 Threading: BSW / BSF, Full Profile

Seite
Page

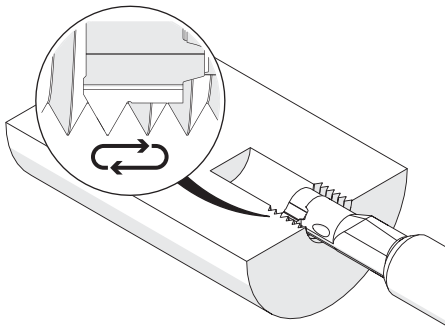
203



Gewinden: ACME / STUB-ACME, Teilprofil
 Threading: ACME / STUB ACME, Partial Profile

Seite
Page

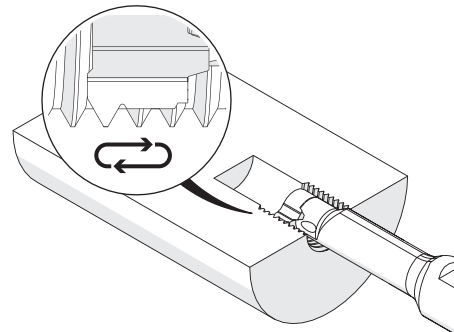
205



Gewinden: NPT, Vollprofil
 Threading: NPT, Full Profile

Seite
Page

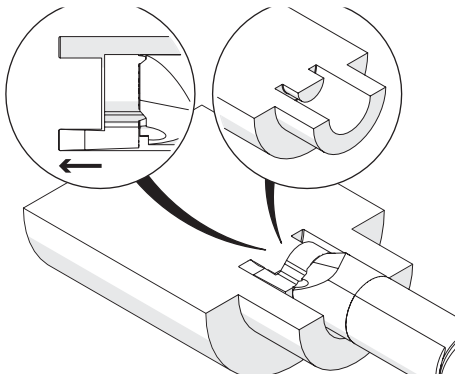
206



Gewinden: UNC/UNF, Vollprofil
 Threading: UNC/UNF, Full Profile

Ab Seite
As of page

207



Axialstechen
 Face Grooving

Klemmhalter, Innenbearbeitung

Schwingungsgedämpfter Hartmetall-Rundschaft mit innerer Kühlmittelzufuhr.

Toolholder, For Internal Applications

Anti-vibration solid carbide round shank toolholder with through coolant.

Anzugsmoment (Schraube) // Tightening torque (screw)

0,8 Nm

Bitte Hinweise im Anhang beachten // Please read add. notes

MASTER (Seite/Page 212)

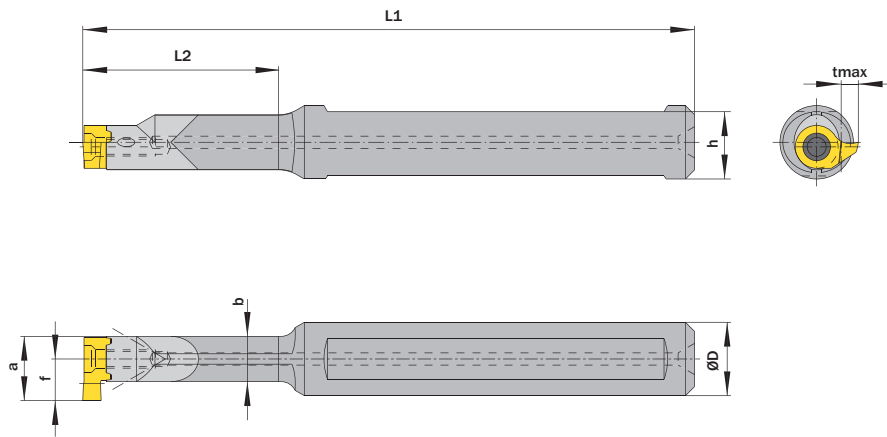


Legende
Legend **213**

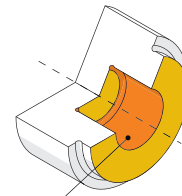


Scan
QR-Code

Oder besuchen Sie // Or Visit
www.simtek.info/cp/979



Maße „a“, „f“ und „tmax“ sind abhängig vom verwendeten Schneideinsatz.
Dimensions „a“, „f“ and tmax depend on used carbide inserts.



- **Hauptsächlich geeignet für diese Flächen**
Mainly designed for these surfaces
- **Je nach Schneidplatte ebenfalls möglich**
Also possible depending on insert type

ØD ^{h6}	L2	Artikelnummer Part number	Webcode www.simtek.com/webcode	b	h	L1	Schraube Screw	Schraubenschlüssel Screw driver	Connectcode www.simtek.com/ccode
mm	mm			mm	mm	mm			
▼ ØD = 12,0 mm									
12,0	21,0	D07.0012.21 HM	AU5Y	4,8	11,0	80,0	D M2x7,5 T7F	T7F	D07
12,0	30,0	D07.0012.30 HM	AU50	4,8	11,0	90,0	D M2x7,5 T7F	T7F	D07
12,0	42,0	D07.0012.42 HM	AU51	4,8	11,0	100,0	D M2x7,5 T7F	T7F	D07
▼ ØD = 12,7 mm									
12,7	21,0	D07.0.500.21 HM	A264	4,8	11,7	80,0	D M2x7,5 T7F	T7F	D07 <small>inch</small>
12,7	30,0	D07.0.500.30 HM	A265	4,8	11,7	90,0	D M2x7,5 T7F	T7F	D07 <small>inch</small>
12,7	42,0	D07.0.500.42 HM	A266	4,8	11,7	100,0	D M2x7,5 T7F	T7F	D07 <small>inch</small>

Verwandte Werkzeuge finden Sie auch auf der folgenden Seite!
Related Items can be found on the following page as well!

Fortgesetzte Tabelle
Continued Table

Bestellbeispiel // Order example: **D07.0012.21 HM**

Klemmhalter, Innenbearbeitung

Schwingungsgedämpfter Hartmetall-Rundschaft mit innerer Kühlmittelzufuhr.

Toolholder, For Internal Applications

Anti-vibration solid carbide round shank toolholder with through coolant.

Anzugsmoment (Schraube) // Tightening torque (screw)

1,5 Nm

Bitte Hinweise im Anhang beachten // Please read add. notes

MASTER (Seite/Page 212)

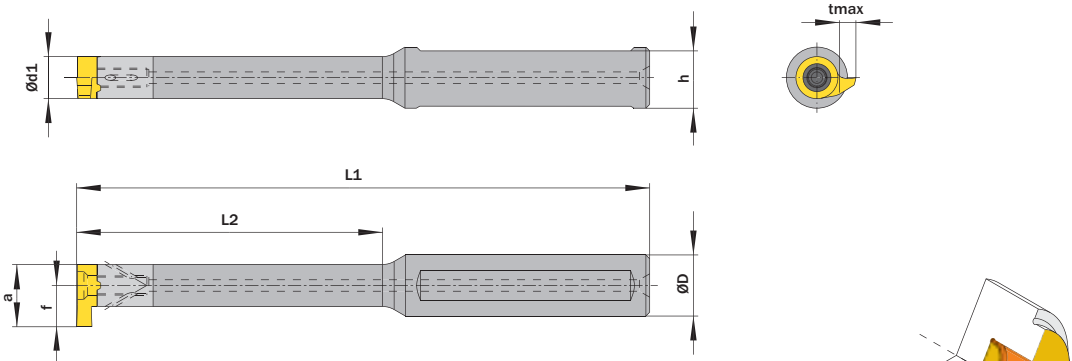


Legende
Legend **213**

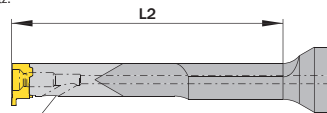


Scan QR-Code

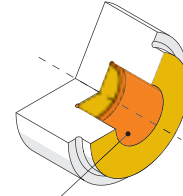
Oder besuchen Sie // Or Visit www.simtek.info/cp/808



Maße „a“, „f“ und „tmax“ sind abhängig vom verwendeten Schneideinsatz.
Dimensions „a“, „f“ and „tmax“ depend on used carbide inserts.



D08.0012.50 HM & D08.0.500.50 HM
Eine Kühlmittelzufuhr.
One through coolant supply.



- Hauptsächlich geeignet für diese Flächen
Mainly designed for these surfaces
- Je nach Schneidplatte ebenfalls möglich
Also possible depending on insert type

Ød ^{h6}	L2	Artikelnummer Part number	Webcode www.simtek.com/webcode	Ød1	h	L1	Schraube Screw	Schraubenschlüssel Screw driver	Connectcode www.simtek.com/code
mm	mm			mm	mm	mm			

Fortgesetzte Tabelle
Continued Table

Verwandte Werkzeuge finden Sie auch auf der vorhergehenden Seite!
Related items can be found on the previous page as well!

▼ ØD = 12,0 mm									
12,0	21,0	D08.0012.21 HM	AF03	6,0	11,5	80,0	D M2,6x8 T8F	T8F	D08
12,0	30,0	D08.0012.30 HM	AB7V	6,0	11,5	90,0	D M2,6x8 T8F	T8F	D08
12,0	42,0	D08.0012.42 HM	AAVA	6,0	11,5	100,0	D M2,6x8 T8F	T8F	D08
12,0	50,0	D08.0012.50 HM	AA9E	6,0	11,5	115,0	D M2,6x8 T8F	T8F	D08
▼ ØD = 12,7 mm									
12,7	21,0	D08.0.500.21 HM	AF99	6,0	12,2	80,0	D M2,6x8 T8F	T8F	D08 tipd
12,7	30,0	D08.0.500.30 HM	AEZK	6,0	12,2	90,0	D M2,6x8 T8F	T8F	D08 inch
12,7	42,0	D08.0.500.42 HM	AHCK	6,0	12,2	100,0	D M2,6x8 T8F	T8F	D08 inch
12,7	50,0	D08.0.500.50 HM	A5T1	6,0	12,2	115,0	D M2,6x8 T8F	T8F	D08 new inch

Verwandte Werkzeuge finden Sie auch auf der folgenden Seite!
Related items can be found on the following page as well!

Fortgesetzte Tabelle
Continued Table

Bestellbeispiel // Order example: **D08.0012.30 HM**

Klemmhalter, Innenbearbeitung

Schwingungsgedämpfter Hartmetall-Rundschaft mit innerer Kühlmittelzufuhr.

Toolholder, For Internal Applications

Anti-vibration solid carbide round shank toolholder with through coolant.

Anzugsmoment (Schraube) // Tightening torque (screw)

1,5 Nm

Bitte Hinweise im Anhang beachten // Please read add. notes

MASTER (Seite/Page 212)

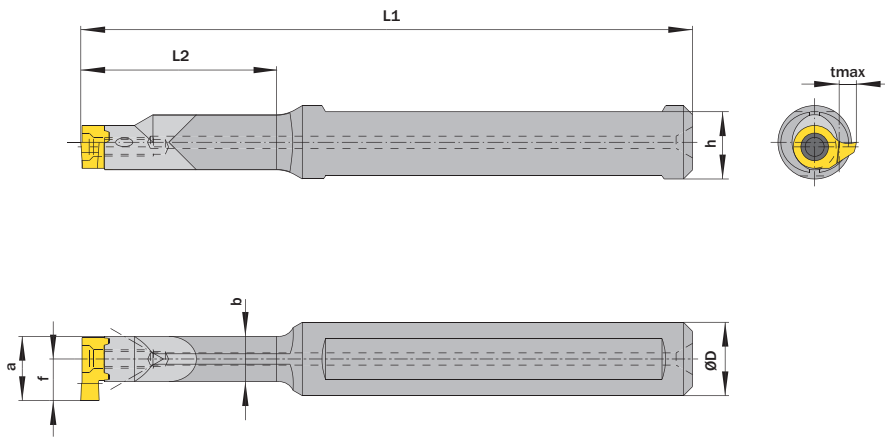


Legende
Legend **213**

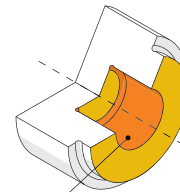


Scan
QR-Code

Oder besuchen Sie // Or Visit
www.simtek.info/cp/989



Maße „a“, „f“ und „tmax“ sind abhängig vom verwendeten Schneideinsatz.
Dimensions „a“, „f“ and tmax depend on used carbide inserts.



- Hauptsächlich geeignet für diese Flächen
Mainly designed for these surfaces
- Je nach Schneidplatte ebenfalls möglich
Also possible depending on insert type

ØD ^{h6}	L2	Artikelnummer Part number	Webcode www.simtek.com/webcode	b	h	L1	Schraube Screw	Schraubenschlüssel Screw driver	Connectcode www.simtek.com/ccode
mm	mm			mm	mm	mm			

◀ Fortgesetzte Tabelle
Continued Table

Verwandte Werkzeuge finden Sie auch auf der vorhergehenden Seite!
Related Items can be found on the previous page as well!

▼ ØD = 12,0 mm									
12,0	22,0	D09.0012.22 HM	AWFD	6,6	11,0	90,0	D M2,6x8 T8F	T8F	D09
12,0	30,0	D09.0012.30 HM	AWFC	6,6	11,0	98,0	D M2,6x8 T8F	T8F	D09
12,0	42,0	D09.0012.42 HM	AWFB	6,6	11,0	110,0	D M2,6x8 T8F	T8F	D09
12,0	56,0	D09.0012.56 HM	AWFA	6,6	11,0	122,0	D M2,6x8 T8F	T8F	D09
▼ ØD = 12,7 mm									
12,7	22,0	D09.0.500.22 HM	A23Z	6,6	11,7	90,0	D M2,6x8 T8F	T8F	D09 <small>new inch</small>
12,7	30,0	D09.0.500.30 HM	A230	6,6	11,7	98,0	D M2,6x8 T8F	T8F	D09 <small>new inch</small>
12,7	42,0	D09.0.500.42 HM	A231	6,6	11,7	110,0	D M2,6x8 T8F	T8F	D09 <small>new inch</small>
12,7	56,0	D09.0500.56 HM	A5T3	6,6	11,7	122,0	D M2,6x8 T8F	T8F	D09 <small>new inch</small>

Verwandte Werkzeuge finden Sie auch auf der folgenden Seite!
Related Items can be found on the following page as well!

▶ Fortgesetzte Tabelle
Continued Table

Bestellbeispiel // Order example: **D09.0012.42 HM**

Klemmhalter, Innenbearbeitung

Schwingungsgedämpfter Hartmetall-Rundschaft mit innerer Kühlmittelzufuhr.

Toolholder, For Internal Applications

Anti-vibration solid carbide round shank toolholder with through coolant.

Anzugsmoment (Schraube) // Tightening torque (screw)

2,1 Nm

Bitte Hinweise im Anhang beachten // Please read add. notes

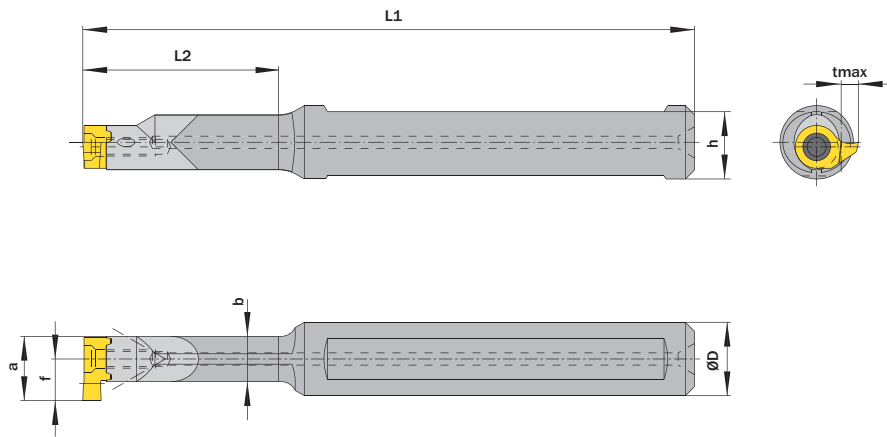
MASTER (Seite/Page 212)



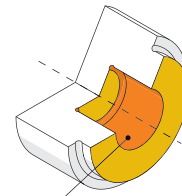
Legende
Legend **213**

Scan QR-Code

Oder besuchen Sie // Or Visit
www.simtek.info/cp/810



Maße „a“, „f“ und „tmax“ sind abhängig vom verwendeten Schneideinsatz.
Dimensions „a“, „f“ and tmax depend on used carbide inserts.



- Hauptsächlich geeignet für diese Flächen
Mainly designed for these surfaces
- Je nach Schneidplatte ebenfalls möglich
Also possible depending on insert type

ØD h6	L2	Artikelnummer Part number	Webcode www.simtek.com/webcode	b	h	L1	Schraube Screw	Schraubenschlüssel Screw driver	Connectcode www.simtek.com/code
mm	mm			mm	mm	mm			

Fortgesetzte Tabelle
Continued Table

Verwandte Werkzeuge finden Sie auch auf der vorhergehenden Seite!
Related items can be found on the previous page as well!

ØD	L2	Artikelnummer	Webcode	b	h	L1	Schraube	Schraubenschlüssel	Connectcode
12,0	24,0	D10.0012.24 HM	AKMV	7,4	11,0	92,0	D M3x9 T9F	T9F	D10
12,0	32,0	D10.0012.32 HM	AJJ7	7,4	11,0	100,0	D M3x9 T9F	T9F	D10
12,0	48,0	D10.0012.48 HM	AHP2	7,4	11,0	115,0	D M3x9 T9F	T9F	D10
12,0	64,0	D10.0012.64 HM	ACB2	7,4	11,0	130,0	D M3x9 T9F	T9F	D10
12,7	22,0	D10.0.500.22 HM	AØY7	7,4	11,7	90,0	D M3x9 T9F	T9F	D10
12,7	32,0	D10.0.500.32 HM	AB32	7,4	11,7	100,0	D M3x9 T9F	T9F	D10
12,7	48,0	D10.0.500.48 HM	APKH	7,4	11,7	115,0	D M3x9 T9F	T9F	D10
12,7	64,0	D10.0.500.64 HM	ADFU	7,4	11,7	130,0	D M3x9 T9F	T9F	D10

Verwandte Werkzeuge finden Sie auch auf der folgenden Seite!
Related items can be found on the following page as well!

Fortgesetzte Tabelle
Continued Table

Bestellbeispiel // Order example: **D10.0012.32 HM**

Klemmhalter, Innenbearbeitung

Schwingungsgedämpfter Hartmetall-Rundschaft mit innerer Kühlmittelzufuhr.

Toolholder, For Internal Applications

Anti-vibration solid carbide round shank toolholder with through coolant.

Anzugsmoment (Schraube) // Tightening torque (screw)

3,0 Nm

Bitte Hinweise im Anhang beachten // Please read add. notes

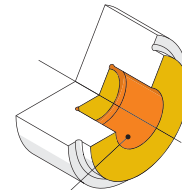
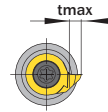
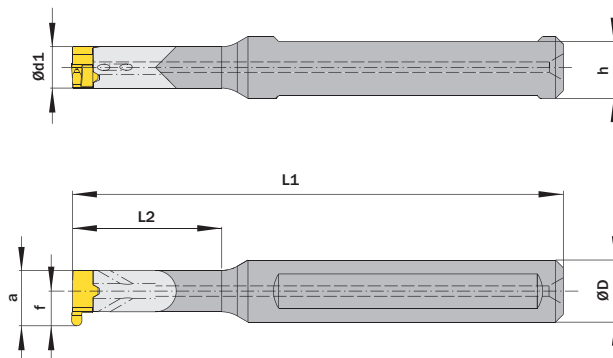
MASTER (Seite/Page 212)



Legende
Legend **213**

Scan QR-Code

Oder besuchen Sie // Or Visit
www.simtek.info/cp/978



Maße „a“, „f“ und „tmax“ sind abhängig vom verwendeten Schneideinsatz.
Dimensions „a“, „f“ and „tmax“ depend on used carbide inserts.

Abbildung zeigt / Drawing shows: D11.0012.29 HM

- Hauptsächlich geeignet für diese Flächen
Mainly designed for these surfaces
- Je nach Schneidplatte ebenfalls möglich
Also possible depending on insert type

ØD^{h6}	L2	Artikelnummer Part number	Webcode www.simtek.com/webcode	Ød1	h	L1	Schraube Screw	Schraubenschlüssel Screw driver	Connectcode www.simtek.com/ccode
mm	mm			mm	mm	mm			

Fortgesetzte Tabelle
Continued Table

Verwandte Werkzeuge finden Sie auch auf der vorhergehenden Seite!
Related items can be found on the previous page as well!

▼ ØD = 12,0 mm									
12,0	29,0	D11.0012.29 HM	AHJ1	8,0	11,0	95,0	D M3,5x10 T10F	T10F	D11
12,0	42,0	D11.0012.42 HM	AG9S	8,0	11,0	110,0	D M3,5x10 T10F	T10F	D11
12,0	56,0	D11.0012.56 HM	AHEF	8,0	11,0	120,0	D M3,5x10 T10F	T10F	D11
12,0	64,0	D11.0012.64 HM	ABD8	8,0	11,0	130,0	D M3,5x10 T10F	T10F	D11
▼ ØD = 12,7 mm									
12,7	29,0	D11.0.500.29 HM	AGZ0	8,0	11,7	95,0	D M3,5x10 T10F	T10F	D11
12,7	42,0	D11.0.500.42 HM	ABCD	8,0	11,7	110,0	D M3,5x10 T10F	T10F	D11 <small>inch</small>
12,7	56,0	D11.0.500.56 HM	AHP0	8,0	11,7	120,0	D M3,5x10 T10F	T10F	D11 <small>inch</small>
12,7	56,0	D11.0.500.64 HM	A5T5	8,0	11,7	130,0	D M3,5x10 T10F	T10F	D11 <small>new inch</small>

Verwandte Werkzeuge finden Sie auch auf der folgenden Seite!
Related items can be found on the following page as well!

Fortgesetzte Tabelle
Continued Table

Bestellbeispiel // Order example: **D11.0012.29 HM**

Klemmhalter, Innenbearbeitung

Schwingungsgedämpfter Hartmetall-Rundschaft mit innerer Kühlmittelzufuhr.

Toolholder, For Internal Applications

Anti-vibration solid carbide round shank toolholder with through coolant.

Anzugsmoment (Schraube) // Tightening torque (screw)

4,5 Nm

Bitte Hinweise im Anhang beachten // Please read add. notes

MASTER (Seite/Page 212)

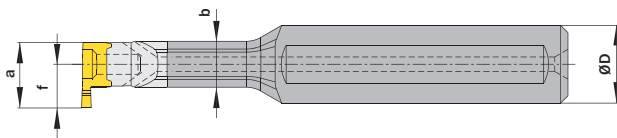
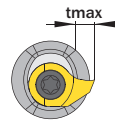
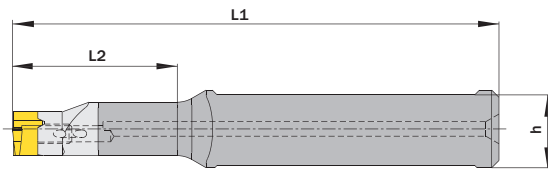


Legende
Legend **213**



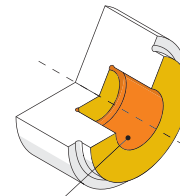
Scan QR-Code

Oder besuchen Sie // Or Visit
www.simtek.info/cp/958



Maße „a“, „f“ und „tmax“ sind abhängig vom verwendeten Schneideinsatz.
Dimensions „a“, „f“ and „tmax“ depend on used carbide inserts.

Abbildung zeigt / Drawing shows: D14.0016.34 HM



- Hauptsächlich geeignet für diese Flächen
Mainly designed for these surfaces
- Je nach Schneidplatte ebenfalls möglich
Also possible depending on insert type

ØD h6	L2	Artikelnummer Part number	Webcode www.simtek.com/webcode	b	h	L1	Schraube Screw	Schraubenschlüssel Screw driver	Connectcode www.simtek.com/code
mm	mm			mm	mm	mm			

Fortgesetzte Tabelle
Continued Table

Verwandte Werkzeuge finden Sie auch auf der vorhergehenden Seite!
Related items can be found on the previous page as well!

▼ ØD = 12,0 mm	ØD	L2	Artikelnummer	Part number	b	h	L1	Schraube	Schraubenschlüssel	Connectcode
12,0	20,0		D14.0012.20 HM	A089	9,5	11,0	75,0	D M4x12 T15F	T15F	D14
12,0	34,0		D14.0012.34 HM	AMQ7	9,5	11,0	100,0	D M4x12 T15F	T15F	D14
12,0	45,0		D14.0012.45 HM	AMYJ	9,5	11,0	110,0	D M4x12 T15F	T15F	D14
12,0	64,0		D14.0012.64 HM	AEQA	9,5	11,0	130,0	D M4x12 T15F	T15F	D14
▼ ØD = 12,7 mm										
12,7	20,0		D14.0.500.20 HM	A5T7	9,5	11,7	75,0	D M4x12 T15F	T15F	D14 <small>new</small>
12,7	34,0		D14.0.500.34 HM	AEBY	9,5	11,7	100,0	D M4x12 T15F	T15F	D14 <small>inch</small>
12,7	45,0		D14.0.500.45 HM	AEZJ	9,5	11,7	110,0	D M4x12 T15F	T15F	D14 <small>inch</small>
12,7	64,0		D14.0.500.64 HM	AAEN	9,5	11,7	130,0	D M4x12 T15F	T15F	D14 <small>inch</small>
▼ ØD = 15,875 mm										
15,875	34,0		D14.0.625.34 HM	AG7B	9,5	14,88	100,0	D M4x12 T15F	T15F	D14 <small>inch</small>
15,875	45,0		D14.0.625.45 HM	AB11	9,5	14,88	110,0	D M4x12 T15F	T15F	D14 <small>inch</small>
15,875	64,0		D14.0.625.64 HM	AAMU	9,5	14,88	130,0	D M4x12 T15F	T15F	D14 <small>inch</small>
▼ ØD = 16,0 mm										
16,0	34,0		D14.0016.34 HM	AFP8	9,5	15,0	100,0	D M4x12 T15F	T15F	D14
16,0	45,0		D14.0016.45 HM	AA1H	9,5	15,0	110,0	D M4x12 T15F	T15F	D14
16,0	64,0		D14.0016.64 HM	AB99	9,5	15,0	130,0	D M4x12 T15F	T15F	D14
16,0	75,0		D14.0016.75 HM	AFD1	9,5	15,0	140,0	D M4x12 T15F	T15F	D14

Verwandte Werkzeuge finden Sie auch auf der folgenden Seite!
Related items can be found on the following page as well!

Fortgesetzte Tabelle
Continued Table

Bestellbeispiel // Order example: **D14.0016.34 HM**

Klemmhalter, Innenbearbeitung

Schwingungsgedämpfter Hartmetall-Rundschaft mit innerer Kühlmittelzufuhr.

Toolholder, For Internal Applications

Anti-vibration solid carbide round shank toolholder with through coolant.

Anzugsmoment (Schraube) // Tightening torque (screw)

7,0 Nm

Bitte Hinweise im Anhang beachten // Please read add. notes

MASTER (Seite/Page 212)

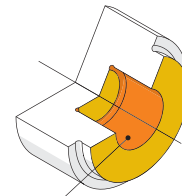
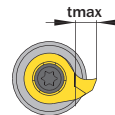
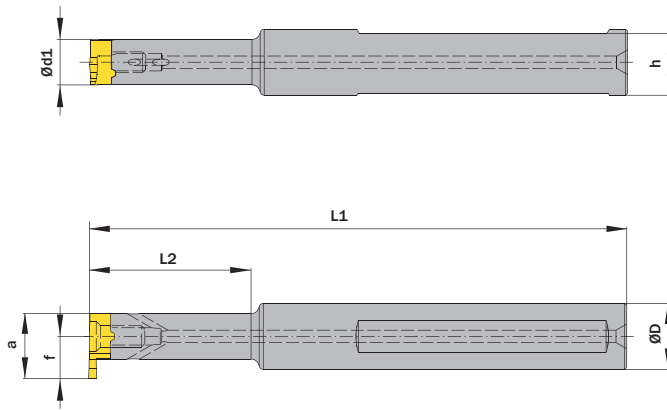


Legende
Legend **213**



Scan
QR-Code

Oder besuchen Sie // Or Visit
www.simtek.info/cp/957



Maße „a“, „f“ und „tmax“ sind abhängig vom verwendeten Schneideinsatz.
Dimensions „a“, „f“ and „tmax“ depend on used carbide inserts.

Abbildung zeigt / Drawing shows: D16.0016.40 HM

- Hauptsächlich geeignet für diese Flächen
Mainly designed for these surfaces
- Je nach Schneidplatte ebenfalls möglich
Also possible depending on insert type

ØD ^{h6}	L2	Artikelnummer Part number	Webcode www.simtek.com/webcode	Ød1	h	L1	Schraube Screw	Schraubenschlüssel Screw driver	Connectcode www.simtek.com/code
mm	mm			mm	mm	mm			

Fortgesetzte Tabelle
Continued Table

Verwandte Werkzeuge finden Sie auch auf der vorhergehenden Seite!
Related items can be found on the previous page as well!

▼ ØD = 12,0 mm									
12,0	40,0	D16.0012.40 HM	AESE	11,0	11,0	130,0	D M5x12 T20T	T20T	D16
12,0	56,0	D16.0012.56 HM	ABY7	11,0	11,0	130,0	D M5x12 T20T	T20T	D16
12,0	80,0	D16.0012.80 HM	AAYX	11,0	11,0	150,0	D M5x12 T20T	T20T	D16
▼ ØD = 12,7 mm									
12,7	40,0	D16.0.500.40 HM	AK10	11,0	11,7	130,0	D M5x12 T20T	T20T	D16 <small>inch</small>
12,7	56,0	D16.0.500.56 HM	AKTU	11,0	11,7	130,0	D M5x12 T20T	T20T	D16 <small>inch</small>
12,7	80,0	D16.0.500.80 HM	APXA	11,0	11,7	150,0	D M5x12 T20T	T20T	D16 <small>inch</small>
▼ ØD = 15,875 mm									
15,875	40,0	D16.0.625.40 HM	APM8	11,0	14,88	130,0	D M5x12 T20T	T20T	D16 <small>inch</small>
15,875	56,0	D16.0.625.56 HM	ADJ3	11,0	14,88	130,0	D M5x12 T20T	T20T	D16 <small>inch</small>
15,875	80,0	D16.0.625.80 HM	AFSY	11,0	14,88	150,0	D M5x12 T20T	T20T	D16 <small>inch</small>
▼ ØD = 16,0 mm									
16,0	40,0	D16.0016.40 HM	ACA6	11,0	15,0	130,0	D M5x12 T20T	T20T	D16
16,0	56,0	D16.0016.56 HM	ABJH	11,0	15,0	130,0	D M5x12 T20T	T20T	D16
16,0	80,0	D16.0016.80 HM	AEF9	11,0	15,0	150,0	D M5x12 T20T	T20T	D16

Verwandte Werkzeuge finden Sie auch auf der folgenden Seite!
Related items can be found on the following page as well!

Fortgesetzte Tabelle
Continued Table

Bestellbeispiel // Order example: **D16.0016.40 HM**

Klemmhalter, Innenbearbeitung

Schwingungsgedämpfter Hartmetall-Rundschaft mit innerer Kühlmittelzufuhr.

Toolholder, For Internal Applications

Anti-vibration solid carbide round shank toolholder with through coolant.

Anzugsmoment (Schraube) // Tightening torque (screw)

7,0 Nm

Bitte Hinweise im Anhang beachten // Please read add. notes

MASTER (Seite/Page 212)

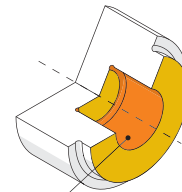
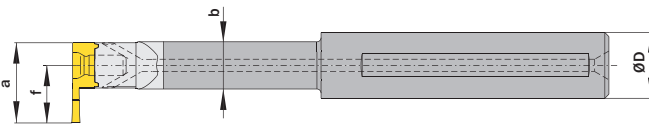
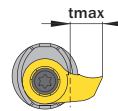
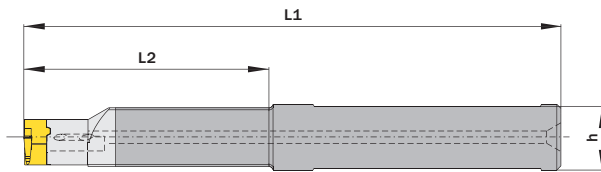


Legende
Legend **213**



Scan
QR-Code

Oder besuchen Sie // Or Visit
www.simtek.info/cp/980



Maße „a“, „f“ und „tmax“ sind abhängig vom verwendeten Schneideinsatz.
Dimensions „a“, „f“ and „tmax“ depend on used carbide inserts.

- Hauptsächlich geeignet für diese Flächen
Mainly designed for these surfaces
- Je nach Schneidplatte ebenfalls möglich
Also possible depending on insert type

Abbildung zeigt / Drawing shows: D18.0016.60 HM

ØD^{h6}	L2	Artikelnummer Part number	Webcode www.simtek.com/webcode	b	h	L1	Schraube Screw	Schraubenschlüssel Screw driver	Connectcode www.simtek.com/code
mm	mm			mm	mm	mm			

Fortgesetzte Tabelle
Continued Table

Verwandte Werkzeuge finden Sie auch auf der vorhergehenden Seite!
Related items can be found on the previous page as well!

▼ ØD = 15,875 mm										
15,875	42,0	D18.0.625.42 HM	AVW3	11,5	14,88	100,0	D M5x12 T20T	T20T	D18	<small>inch</small>
15,875	60,0	D18.0.625.60 HM	AVW4	11,5	14,88	130,0	D M5x12 T20T	T20T	D18	<small>inch</small>
15,875	85,0	D18.0.625.85 HM	AVW5	11,5	14,88	160,0	D M5x12 T20T	T20T	D18	<small>inch</small>
▼ ØD = 16,0 mm										
16,0	42,0	D18.0016.42 HM	AEP1	11,5	15,0	100,0	D M5x12 T20T	T20T	D18	
16,0	60,0	D18.0016.60 HM	AJFC	11,5	15,0	130,0	D M5x12 T20T	T20T	D18	
16,0	85,0	D18.0016.85 HM	AF5G	11,5	15,0	160,0	D M5x12 T20T	T20T	D18	
▼ ØD = 19,05 mm										
19,05	85,0	D18.0.750.85 HM	AVW6	11,5	18,08	160,0	D M5x12 T20T	T20T	D18	<small>inch</small>
▼ ØD = 20,0 mm										
20,0	85,0	D18.0020.85 HM	AG1A	11,5	19,0	160,0	D M5x12 T20T	T20T	D18	

Bestellbeispiel // Order example: **D18.0016.42 HM**

Kleinteilebearbeitung // Small Part Machining

simturn DX > Trägerwerkzeug // Toolholder

Längenverstellbarer Klemmhalter, Innenbearbeitung, Rundschaft, „ME“



Rundschaft aus Stahl. Dank ME-Spannsystem für kraftschlüssiges Spannen ist das innenliegende Hartmetall-Trägerwerkzeug stabil und präzise stufenlos in der Länge verstellbar.

Length Adjustable Toolholder, Internal Applications, Round Shank, „ME“

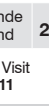
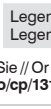
Steel round shank. Thanks to the ME-clamping system for force-fitted clamping, the internal carbide toolholder can be infinitely and precisely adjusted in length with great stability.

Anzugsmoment (Schraube) // Tightening Torque (Screw)

6,0 Nm - 10,0 Nm

Bitte Hinweise im Anhang beachten // Please read add. notes

MASTER (Seite/Page 212)

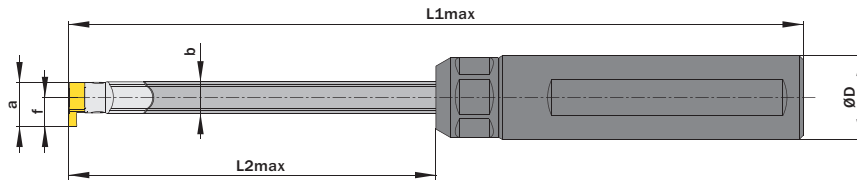
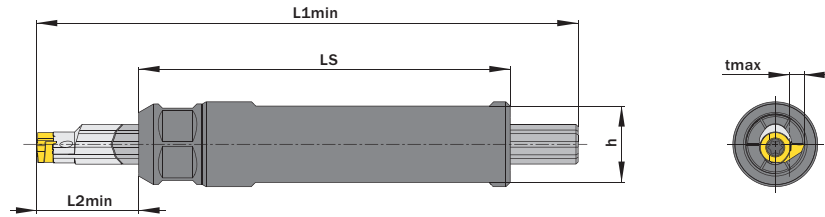


Scan QR-Code

Oder besuchen Sie // Or Visit www.simtek.info/cp/1311

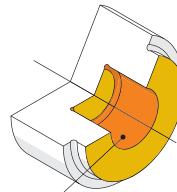
Legende

213



Maße „a“, „f“ und „tmax“ sind abhängig vom verwendeten Schneideinsatz. Dimensions „a“, „f“ and „tmax“ depend on used carbide inserts.

Anzugsmoment (Mutter) // Tightening Torque (Screw nut)
15,0 Nm - 25,0 Nm



- Hauptsächlich geeignet für diese Flächen
Mainly designed for these surfaces
- Je nach Schneidplatte ebenfalls möglich
Also possible depending on insert type

Abbildung zeigt / Drawing shows: D10.0020.24.087 ME

ØD	L2min	L2max	Artikelnummer Part number	Webcode www.simtek.com/webcode	b	h	LS ±0,5	L1min	L1max	Schraube Screw	Standard Mutter Standard screw nut	Connectcode www.simtek.com/code
mm ⁸⁶	mm	mm			mm	mm	mm	mm	mm			
▼ ØD = 19,05 mm												
19,05	31,0	87,5	D10.0.750.24.087 ME	A5XH	7,5	17,0	87,5	127,5	175,0	D M3x9 T9F	A00.K.19.15.138	D10 new inch
19,05	42,0	124,0	D14.0.750.25.124 ME	A5XK	9,5	17,0	87,5	164,0	211,5	D M4x12 T15F	A00.K.19.15.138	D14 new inch
▼ ØD = 20,0 mm												
20,0	31,0	87,5	D10.0020.24.087 ME	A2ZA	7,5	18,0	87,5	127,5	175,0	D M3x9 T9F	A00.K.19.15.138	D10 upd
20,0	42,0	124,0	D14.0020.25.124 ME	A2ZB	9,5	18,0	90,0	164,0	214,0	D M4x12 T15F	A00.K.19.15.138	D14 upd

Bestellbeispiel // Order example: **D10.0020.24.087 ME**

simturn AX
simturn DX
simturn PX
simturn H2
simturn K2
simturn C4
simturn GX
simturn E3
simturn E12
simturn FX
simturn Decolletage
simturn OA
Index

Klemmhalter / Adapter, Innenbearbeitung

Adapter für D07-Schneidplatten auf A06-Klemmhalter.
Schwingungsgedämpfter Hartmetall-Rundschaft mit innerer Kühlmittelzufuhr.

Toolholder / Adapter, For Internal Applications

Adapter for D07 inserts on A06 toolholder.
Anti-vibration solid carbide round shank toolholder with through coolant.

Anzugsmoment (Schraube) // Tightening torque (screw)

0,8 Nm

Bitte Hinweise im Anhang beachten // Please read add. notes

MASTER (Seite/Page 212)

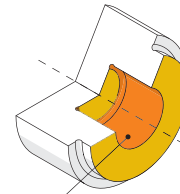
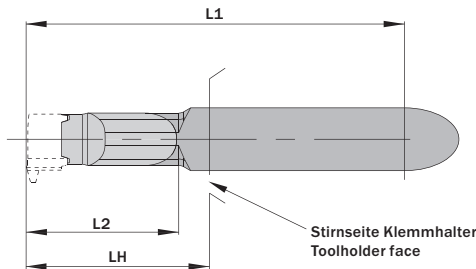
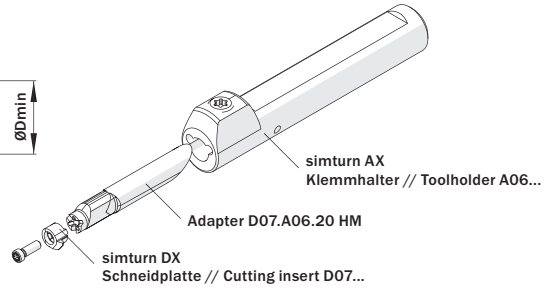
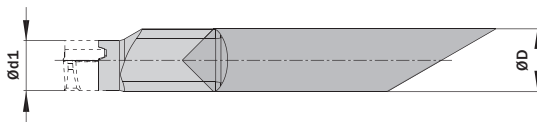


Legende
Legend **213**



Scan
QR-Code

Oder besuchen Sie // Or Visit
www.simtek.info/cp/809



- **Hauptsächlich geeignet für diese Flächen**
Mainly designed for these surfaces
- **Je nach Schneidplatte ebenfalls möglich**
Also possible depending on insert type

Abbildung zeigt / Drawing shows: D07.A06.20 HM

ØD ^{h6}	L2	Artikelnummer Part number	Webcode www.simtek.com/webcode	Ød1	ØDmin (Min. Bohrung) ØDmin (min. bore)	L1	LH	Schraube Screw	Schraubenschlüssel Screw driver	Connectcode www.simtek.com/code
mm	mm			mm	mm	mm	mm			
▼ L2 = 20,0 mm										
6,0	20,0	D07.A06.20 HM	AHSC	4,8	7,0	42,25	23,0	D M2x7,5 T7F	T7F	D07
▼ L2 = 30,0 mm										
6,0	30,0	D07.A06.30 HM	AJ5U	4,8	7,0	52,25	33,0	D M2x7,5 T7F	T7F	D07
▼ L2 = 40,0 mm										
6,0	40,0	D07.A06.40 HM	AAVG	4,8	7,0	62,25	43,0	D M2x7,5 T7F	T7F	D07
▼ L2 = 50,0 mm										
6,0	50,0	D07.A06.50 HM	ACBT	4,8	7,0	72,25	53,0	D M2x7,5 T7F	T7F	D07
▼ L2 = 60,0 mm										
6,0	60,0	D07.A06.60 HM	AKSW	4,8	7,0	82,25	63,0	D M2x7,5 T7F	T7F	D07

Bestellbeispiel // Order example: **D07.A06.40 HM**

Klemmhalter, Innenbearbeitung

Stahl-Rundschaft mit innerer Kühlmittelzufuhr.

Toolholder, For Internal Applications

Steel round shank toolholder with through coolant.

Anzugsmoment (Schraube) // Tightening torque (screw)

"D M2,6x8 T8F": 1,5 Nm
"D M3,5x10 T10F": 3,0 Nm
"D M5x12 T20T": 7,0 Nm

Bitte Hinweise im Anhang beachten // Please read add. notes

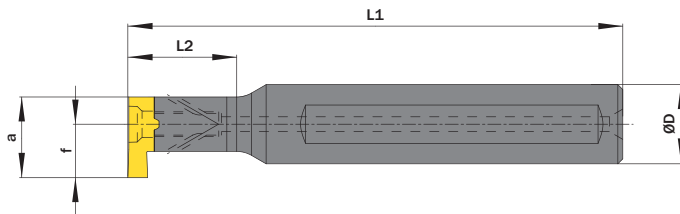
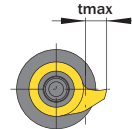
MASTER (Seite/Page 212)



Legende
Legend **213**

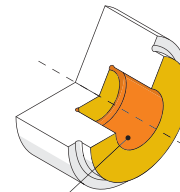
Scan
QR-Code

Oder besuchen Sie // Or Visit
www.simtek.info/cp/811



Maße „a“, „f“ und „tmax“ sind abhängig vom verwendeten Schneideinsatz.
Dimensions „a“, „f“ and „tmax“ depend on used carbide inserts.

Abbildung zeigt / Drawing shows: D16.0016.22 ST



- Hauptsächlich geeignet für diese Flächen
Mainly designed for these surfaces
- Je nach Schneidplatte ebenfalls möglich
Also possible depending on insert type

ØD ^{g6}	L2	Artikelnummer Part number	Webcode www.simtek.com/webcode	Ød1	h	L1	Schraube Screw	Schraubenschlüssel Screw driver	Connectcode www.simtek.com/code
mm	mm			mm	mm	mm			
▼ Connectcode = D08									
12,0	21,0	D08.0012.21 ST	AKHT	6,0	11,0	80,0	D M2,6x8 T8F	T8F	D08
16,0	12,0	D08.0016.12 ST	AH2A	6,0	15,0	80,0	D M2,6x8 T8F	T8F	D08
12,7	12,0	D08.0.500.12 ST	A22H	6,0	12,2	80,0	D M2,6x8 T8F	T8F	D08 inch
15,875	12,0	D08.0.625.12 ST	ABT9	6,0	14,88	80,0	D M2,6x8 T8F	T8F	D08 inch
▼ Connectcode = D11									
12,0	29,0	D11.0012.29 ST	AAV0	8,0	11,0	95,0	D M3,5x10 T10F	T10F	D11
16,0	16,0	D11.0016.16 ST	ANMK	8,0	15,0	97,0	D M3,5x10 T10F	T10F	D11
15,875	16,0	D11.0.625.16 ST	AGFE	8,0	14,88	97,0	D M3,5x10 T10F	T10F	D11 inch
▼ Connectcode = D16									
16,0	22,0	D16.0016.22 ST	AEQC	11,0	15,0	100,0	D M5x12 T20T	T20T	D16
15,875	22,0	D16.0.625.22 ST	ADXJ	11,0	14,88	100,0	D M5x12 T20T	T20T	D16 inch

Bestellbeispiel // Order example: **D16.0016.22 ST**

Klemmhalter, Innenbearbeitung

Stahl-Rundschaft mit innerer Kühlmittelzufuhr.

Toolholder, For Internal Applications

Steel round shank toolholder with through coolant.

Anzugsmoment (Schraube) // Tightening torque (screw)

- "D M2,6x8 T8F": 1,5 Nm
- "D M2x7,5 T7F": 0,8 Nm
- "D M3x9 T9F": 2,1 Nm
- "D M4x12 T15F": 4,5 Nm
- "D M5x12 T20T": 7,0 Nm

Bitte Hinweise im Anhang beachten // Please read add. notes

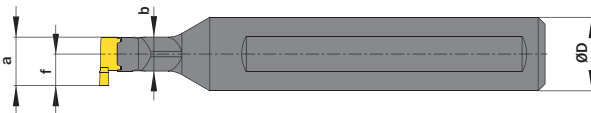
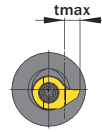
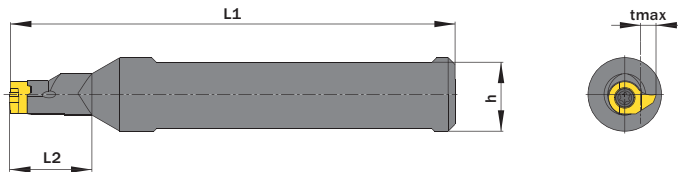
MASTER (Seite/Page 212)



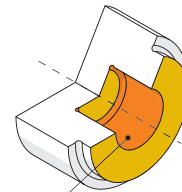
Legende
Legend **213**

Scan
QR-Code

Oder besuchen Sie // Or Visit
www.simtek.info/cp/812



Maße „a“, „f“ und „tmax“ sind abhängig vom verwendeten Schneideinsatz.
Dimensions „a“, „f“ and „tmax“ depend on used carbide inserts.



- Hauptsächlich geeignet für diese Flächen
Mainly designed for these surfaces
- Je nach Schneidplatte ebenfalls möglich
Also possible depending on insert type

Abbildung zeigt / Drawing shows: D10.0016.16 ST

ØD ^{g6} mm	L2 mm	Artikelnummer Part number	Webcode www.simtek.com/webcode	b mm	h mm	L1 mm	Schraube Screw	Schraubenschlüssel Screw driver	Connectcode www.simtek.com/code
▼ Connectcode = D07									
12,0	21,0	D07.0012.21 ST	AU5Z	4,8	11,0	80,0	D M2x7,5 T7F	T7F	D07
16,0	12,0	D07.0016.12 ST	AU6A	4,8	15,0	80,0	D M2x7,5 T7F	T7F	D07
12,7	21,0	D07.0.500.21 ST	A5T9	4,8	11,7	80,0	D M2x7,5 T7F	T7F	D07 <small>new inch</small>
15,875	12,0	D07.0.625.12 ST	A5UB	4,8	14,88	80,0	D M2x7,5 T7F	T7F	D07 <small>new inch</small>
▼ Connectcode = D09									
16,0	14,0	D09.0016.14 ST	AWFE	6,6	15,0	95,0	D M2,6x8 T8F	T8F	D09
15,875	14,0	D09.0.625.14 ST	A3UH	6,6	14,88	95,0	D M2,6x8 T8F	T8F	D09 <small>new inch</small>
▼ Connectcode = D10									
16,0	16,0	D10.0016.16 ST	ACCJ	7,4	15,0	97,0	D M3x9 T9F	T9F	D10
16,0	24,0	D10.0016.24 ST	A016	7,4	15,0	97,0	D M3x9 T9F	T9F	D10
15,875	16,0	D10.0.625.16 ST	ABKU	7,4	14,88	97,0	D M3x9 T9F	T9F	D10 <small>inch</small>
15,875	24,0	D10.0.625.24 ST	A017	7,4	14,88	105,0	D M3x9 T9F	T9F	D10 <small>inch</small>
▼ Connectcode = D14									
16,0	20,0	D14.0016.20 ST	ANP6	9,5	15,0	100,0	D M4x12 T15F	T15F	D14
16,0	30,0	D14.0016.30 ST	A005	9,5	15,0	100,0	D M4x12 T15F	T15F	D14
15,875	20,0	D14.0.625.20 ST	ADZ8	9,5	14,88	100,0	D M4x12 T15F	T15F	D14 <small>inch</small>
15,875	30,0	D14.0.625.30 ST	A5UD	9,5	14,88	100,0	D M4x12 T15F	T15F	D14 <small>new inch</small>
▼ Connectcode = D18									
20,0	25,0	D18.0020.25 ST	AAWH	11,5	19,0	95,0	D M5x12 T20T	T20T	D18
20,0	40,0	D18.0020.40 ST	APH3	11,5	19,0	105,0	D M5x12 T20T	T20T	D18
19,05	25,0	D18.0.750.25 ST	AVW1	11,48	18,05	95,0	D M5x12 T20T	T20T	D18 <small>inch</small>
19,05	40,0	D18.0.750.40 ST	AVW2	11,48	18,05	105,0	D M5x12 T20T	T20T	D18 <small>inch</small>

Bestellbeispiel // Order example: **D14.0016.20 ST**

Klemmhalter, Axialbearbeitung

Schwingungsgedämpfter Stahl- und Hartmetall-Rundschaft mit optimierter innerer Kühlmittelzufuhr für Axialbearbeitungen.

Toolholder, Face Grooving Applications

Anti-vibration solid steel and carbide round shank with optimized through coolant for face grooving applications.

Anzugsmoment (Schraube) // Tightening torque (screw)

"D M4x12 T15F": 4,5 Nm
"D M5x12 T20T": 7,0 Nm

Bitte Hinweise im Anhang beachten // Please read add. notes

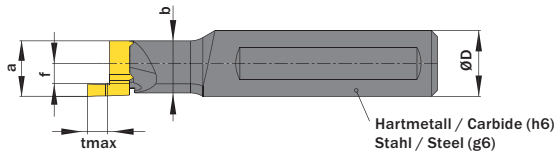
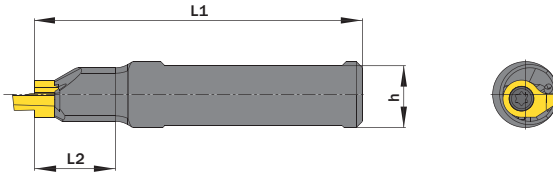
MASTER (Seite/Page 212)



Legende
Legend **213**

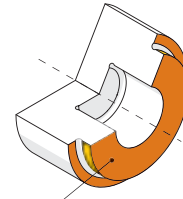
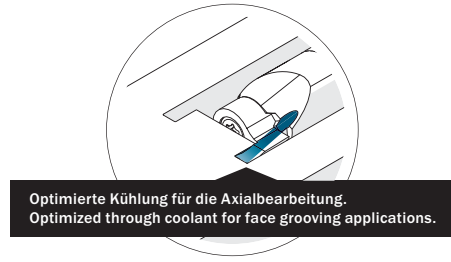


Scan QR-Code Oder besuchen Sie // Or Visit www.simtek.info/cp/807



Maße „a“, „f“ und „tmax“ sind abhängig vom verwendeten Schneideinsatz.
Dimensions „a“, „f“ and „tmax“ depend on used carbide inserts.

Abbildung zeigt / Drawing shows: D14.A.0016.20 ST R



- Hauptsächlich geeignet für diese Flächen
Mainly designed for these surfaces
- Je nach Schneidplatte ebenfalls möglich
Also possible depending on insert type

ØD	L2	Artikelnummer Part number	Webcode www.simtek.com/webcode	Stahl Steel	Hartmetall Carbide	b	h	L1	Schraube Screw	Schraubenschlüssel Screw driver	Connectcode www.simtek.com/code	
mm	mm					mm	mm	mm				
▼ Connectcode = D14.A.L D14.A.R												
15,875	62,0	D14.A.0.625.60 HM R	A5W1	-	x	12,7	14,9	120,0	DM4x12 T15F	T15F	D14.A.L D14.A.R	new inch
▼ Connectcode = D14.A.L D14.A.R / D14.A.L D14.A.R												
15,875	42,0	D14.A.0.625.42 HM R/L	R A4V9 L A4V7	-	x	12,7	14,9	100,0	DM4x12 T15F	T15F R	D14.A.L D14.A.R L	new inch
15,875	5,6	D14.A.0.625.05 STR/L	R A5UF L A5UH	x	-	12,7	14,9	70,0	DM4x12 T15F	T15F R	D14.A.L D14.A.R L	new inch
15,875	20,0	D14.A.0.625.20 STR/L	R A4UH L A4UK	x	-	12,7	14,9	80,0	DM4x12 T15F	T15F R	D14.A.L D14.A.R L	new inch
▼ Connectcode = D14.A.R / D14.A.L												
16,0	5,3	D14.A.0016.05 ST R/L	R AB51 L AJ02	x	-	12,7	15,0	70,0	DM4x12 T15F	T15F R	D14.A.R L	D14.A.L
16,0	20,0	D14.A.0016.20 ST R/L	R AE7Z L AJ7N	x	-	12,7	15,0	80,0	DM4x12 T15F	T15F R	D14.A.R L	D14.A.L
16,0	42,0	D14.A.0016.42 HM R/L	R ABY3 L AKPP	-	x	12,7	15,0	100,0	DM4x12 T15F	T15F R	D14.A.R L	D14.A.L
16,0	62,0	D14.A.0016.60 HM R/L	R AQDY L AQDX	-	x	12,7	15,0	120,0	DM4x12 T15F	T15F R	D14.A.R L	D14.A.L
▼ Connectcode = D18.16.A.R D18.18.A.R / D18.16.A.L D18.18.A.L												
20,0	5,6	D18.A.0020.05.18 ST R/L	R AT09 L AVS0	x	-	-	19,0	85,0	DM5x12 T20T	T20T R	D18.16.A.R D18.18.A.R L	D18.16.A.L D18.18.A.L
19,05	5,6	D18.A.0.750.05.18 ST R/L	R A5UK L A5UN	x	-	-	18,0	85,0	DM5x12 T20T	T20T R	D18.16.A.R D18.18.A.R L	D18.16.A.L D18.18.A.L new inch

Bestellbeispiel // Order example: **D14.A.0016.20 ST R** (R = Rechte Ausführung // Right hand version)

simturn AX
simturn DX
simturn PX
simturn H2
simturn K2
simturn C4
simturn GX
simturn E3
simturn E12
simturn FX
simturn Decolletage
simturn OA
Index

Klemmhalter, Axialbearbeitung

Stahl-Quadratschaft für Axialbearbeitungen.

Toolholder, Face Grooving Applications

Steel square shank toolholder for face grooving applications.

Anzugsmoment (Schraube) // Tightening torque (screw)

"D M4x12 T15F": 4,5 Nm
"D M5x12 T20T": 7,0 Nm

Bitte Hinweise im Anhang beachten // Please read add. notes

MASTER (Seite/Page 212)



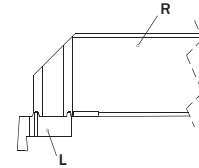
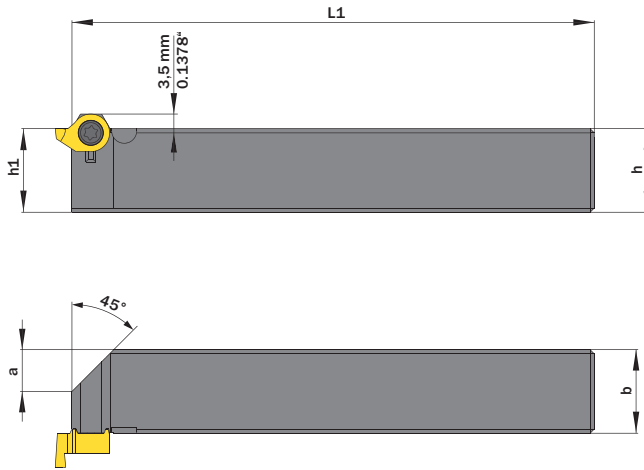
TW
ST

Legende
Legend **213**

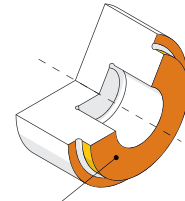


Scan
QR-Code

Oder besuchen Sie // Or Visit
www.simtek.info/cp/804



Bitte beachten: Rechter Halter wird mit linker Platte bestückt und umgekehrt.
Please use right hand toolholder with left hand insert and vice versa.



- Hauptsächlich geeignet für diese Flächen
Mainly designed for these surfaces
- Je nach Schneidplatte ebenfalls möglich
Also possible depending on insert type

Abbildung zeigt / Drawing shows: D14.2020.ST R

h	b	Artikelnummer Part number	Webcode www.simtek.com/webcode	a	h1	L1	Schraube Screw	Schraubenschlüssel Screw driver	Connectcode www.simtek.com/code
mm	mm			mm	mm	mm			
▼ Connectcode = D14.A.L / D14.A.R									
12,0	12,0	D14.1212.ST R/L	R AB16 L AB61	2,0	12,0	100,0	D M4x12 T15F	T15F R	D14.A.L L D14.A.R
16,0	16,0	D14.1616.ST R/L	R ABDB L APA7	6,0	16,0	125,0	D M4x12 T15F	T15F R	D14.A.L L D14.A.R
20,0	20,0	D14.2020.ST R/L	R APDC L AMY4	10,0	20,0	125,0	D M4x12 T15F	T15F R	D14.A.L L D14.A.R
25,0	25,0	D14.2525.ST R/L	R ANUG L ANQ0	15,0	25,0	150,0	D M4x12 T15F	T15F R	D14.A.L L D14.A.R
▼ Connectcode = D18.16.A.L D18.18.A.L / D18.16.A.R D18.18.A.R									
20,0	20,0	D18.2020.ST R/L	R AVS2 L AT9W	10,0	20,0	125,0	D M5x12 T20T	T20T R	D18.16.A.L D18.18.A.L L D18.16.A.R D18.18.A.R
25,0	25,0	D18.2525.ST R/L	R AVGE L AVFZ	15,0	25,0	150,0	D M5x12 T20T	T20T R	D18.16.A.L D18.18.A.L L D18.16.A.R D18.18.A.R

Bestellbeispiel // Order example: **D14.2525.ST R** (R = Rechte Ausführung // Right hand version)

Klemmhalter, Axialbearbeitung

Stahl-Quadratschaft für Axialbearbeitungen, abgesetzte Version.

Toolholder, Face Grooving Applications

Steel square shank toolholder, with offset, for face grooving applications.

Anzugsmoment (Schraube) // Tightening torque (screw)

"D M4x12 T15F": 4,5 Nm
"D M5x12 T20T": 7,0 Nm

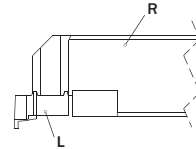
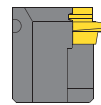
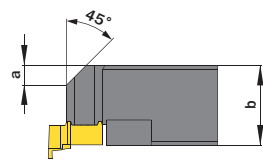
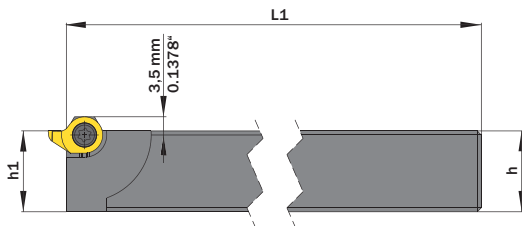
Bitte Hinweise im Anhang beachten // Please read add. notes

MASTER (Seite/Page 212)

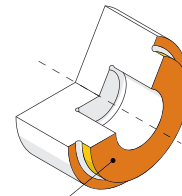


TW Legende
ST Legend **213**

Scan QR-Code Oder besuchen Sie // Or Visit www.simtek.info/cp/806



Bitte beachten: Rechter Halter wird mit linker Platte bestückt und umgekehrt.
Please use right hand toolholder with left hand insert and vice versa.



- Hauptsächlich geeignet für diese Flächen
Mainly designed for these surfaces
- Je nach Schneidplatte ebenfalls möglich
Also possible depending on insert type

Abbildung zeigt / Drawing shows: D14.2020.B.120 ST R

h	b	Artikelnummer Part number	Webcode www.simtek.com/webcode	a	h1 _{js14}	L1	Schraube Screw	Schraubenschlüssel Screw driver	Connectcode www.simtek.com/ccode
mm	mm			mm	mm	mm			
▼ Connectcode = D14.A.L / D14.A.R									
12,0	12,0	D14.1212.B.100 ST R/L	R ASEY L ASEY	4,0	12,0	100,0	D M4x12 T15F	T15F R	D14.A.L L D14.A.R
12,7	12,7	D14.0.500.S.B.100 ST R/L	R AS38 L AS34	4,0	12,7	100,0	D M4x12 T15F	T15F R	D14.A.L L D14.A.R inch
15,875	15,88	D14.0.625.S.B.120 ST R/L	R AS39 L AS35	5,0	15,88	120,0	D M4x12 T15F	T15F R	D14.A.L L D14.A.R inch
16,0	16,0	D14.1616.B.120 ST R/L	R ASEU L ASET	5,0	16,0	120,0	D M4x12 T15F	T15F R	D14.A.L L D14.A.R
19,05	19,05	D14.0.750.S.B.120 ST R/L	R AS4A L AS36	5,0	19,05	120,0	D M4x12 T15F	T15F R	D14.A.L L D14.A.R inch
20,0	20,0	D14.2020.B.120 ST R/L	R ASES L ASEQ	5,0	20,0	120,0	D M4x12 T15F	T15F R	D14.A.L L D14.A.R
25,0	25,0	D14.2525.B.150 ST R/L	R ASEN L ASEP	9,0	25,0	150,0	D M4x12 T15F	T15F R	D14.A.L L D14.A.R
25,4	25,4	D14.1.000.S.B.150 ST R/L	R AS4B L AS37	9,0	25,4	150,0	D M4x12 T15F	T15F R	D14.A.L L D14.A.R inch
▼ Connectcode = D18.16.A.L / D18.18.A.L / D18.16.A.R / D18.18.A.R									
19,05	19,05	D18.0.750.B.120 ST R/L	R ASUT L ASUQ	5,0	19,05	120,0	D M5x12 T20T	T20T R	D18.16.A.L L D18.16.A.R D18.18.A.L L D18.18.A.R new inch
20,0	20,0	D18.2020.B.120 ST R/L	R AVS1 L AT9Y	5,0	20,0	120,0	D M5x12 T20T	T20T R	D18.16.A.L L D18.16.A.R D18.18.A.L L D18.18.A.R
25,0	25,0	D18.2525.B.120 ST R/L	R AWDH L AVF0	9,0	25,0	120,0	D M5x12 T20T	T20T R	D18.16.A.L L D18.16.A.R D18.18.A.L L D18.18.A.R
25,4	25,4	D18.1.000.B.120 ST R/L	R ASUX L ASUV	9,0	25,4	120,0	D M5x12 T20T	T20T R	D18.16.A.L L D18.16.A.R D18.18.A.L L D18.18.A.R new inch

Bestellbeispiel // Order example: D14.2020.B.120 ST R (R = Rechte Ausführung // Right hand version)

Ausdrehen

Geeignet ab Bohrungsdurchmesser 7,0 mm.

Boring

For use in bores as of minimum bore diameter 7,0 mm.

Schnittwerte (Start) // Cutting parameters (start)

f	Vc
0,02 mm/U	Seite/Page 429

Passende Klemmhalter auf Seite // Suitable toolholders on page

153, 154, 155, 156, 157, 158, 159, 161, 162, 163, 164



Legende Legend 213
 Oder besuchen Sie // Or Visit www.simtek.info/cp/813

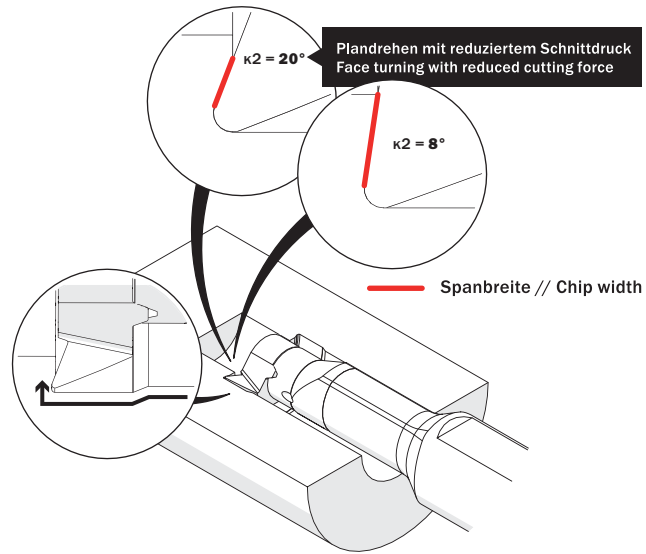
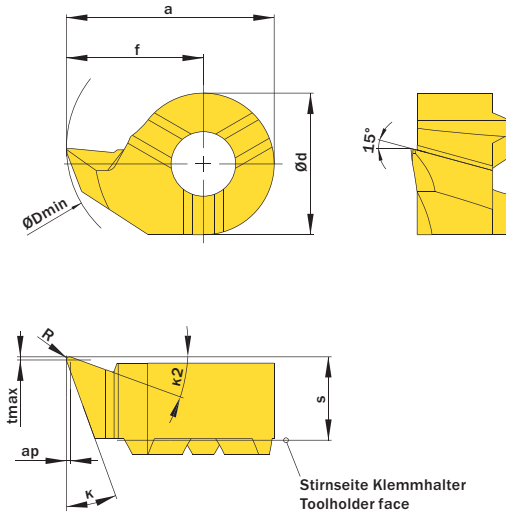


Abbildung zeigt / Drawing shows: D14.2087.02 YR

ØDmin (Min. Bohrung) // ØDmin (min. bore)	k	κ2	f	R	Artikelnummer Part number	Webcode www.simtek.com/webcode	Unsere erste Wahl Our first choice	a	Ød	S	ap	tmax	Connectcode www.simtek.com/code	
mm			mm	mm			P K M N S	mm	mm	mm	mm	mm		
▼ ØDmin (Min. Bohrung) // ØDmin (min. bore) = 7,0 mm														
7,0	18°	8°	4,15	0,1	D07.1841.01 YR/L	R ANWE	L AXA8 X800 X400	6,55	4,8	3,7	0,13	0,2	D07	upd
7,0	18°	8°	4,15	0,2	D07.1841.02 YR/L	R AJZ7	L AXA9 X800 X400	6,55	4,8	3,7	0,25	0,2	D07	upd
▼ ØDmin (Min. Bohrung) // ØDmin (min. bore) = 7,8 mm														
7,8	18°	8°	4,65	0,05	D08.1846.005 YR/L	R AS56	L AS55 X800 X400	7,65	6,0	3,5	0,07	0,2	D08	
7,8	18°	8°	4,65	0,2	D08.1846.02 YR/L	R AMM3	L AC6Z X800 X400	7,65	6,0	3,5	0,25	0,2	D08	
7,8	20°	20°	4,65	0,2	D08.2046.02 YR/L	R AG7V	L AFEB X800 X400	7,65	6,0	3,5	0,25	0,2	D08	
▼ ØDmin (Min. Bohrung) // ØDmin (min. bore) = 9,0 mm														
9,0	18°	8°	5,5	0,2	D09.1855.02.09 YR/L	R AWGU	L AWH7 X800 X400	8,6	6,2	3,6	0,25	0,2	D09	
9,0	20°	20°	5,5	0,2	D09.2055.02.09 YR/L	R AWGV	L AWH8 X800 X400	8,6	6,2	3,6	0,25	0,2	D09	
▼ ØDmin (Min. Bohrung) // ØDmin (min. bore) = 9,8 mm														
9,8	18°	8°	5,5	0,2	D11.1855.02 YR/L	R AC65	L AHXM X800 X400	9,5	8,0	4,2	0,25	0,2	D11	
▼ ØDmin (Min. Bohrung) // ØDmin (min. bore) = 10,0 mm														
10,0	18°	8°	5,6	0,2	D10.1856.02.10 YR/L	R AN4S	L AGF7 X800 X400	9,1	7,0	3,9	0,25	0,2	D10	
10,0	20°	20°	5,6	0,2	D10.2056.02.10 YR/L	R AD7E	L AB48 X800 X400	9,1	7,0	3,9	0,25	0,2	D10	
▼ ØDmin (Min. Bohrung) // ØDmin (min. bore) = 11,0 mm														
11,0	18°	8°	6,6	0,2	D10.1866.02.11 YR/L	R AFCG	L AW40 X800 X400	9,1	7,0	3,9	0,25	0,2	D10	
11,0	18°	8°	6,7	0,2	D11.1867.02 YR/L	R ABXG	L AF60 X800 X400	10,7	8,0	4,2	0,25	0,2	D11	
11,0	20°	20°	6,7	0,2	D11.2067.02 YR/L	R APSF	L AKP5 X800 X400	10,7	8,0	4,2	0,25	0,2	D11	
▼ ØDmin (Min. Bohrung) // ØDmin (min. bore) = 13,8 mm														
13,8	18°	8°	8,7	0,2	D14.1887.02 YR/L	R AN1M	L AGJY X800 X400	13,2	9,0	5,3	0,25	0,2	D14	
13,8	18°	8°	8,7	0,4	D14.1887.04 YR/L	R AZF7	L AZF8 X800 X400	13,2	9,0	5,3	0,5	0,2	D14	upd
13,8	20°	20°	8,7	0,2	D14.2087.02 YR/L	R AG2U	L AGQC X800 X400	13,2	9,0	5,3	0,25	0,2	D14	
▼ ØDmin (Min. Bohrung) // ØDmin (min. bore) = 15,5 mm														
15,5	18°	8°	9,7	0,2	D16.1897.02 YR/L	R AHEA	L ADN X800 X400	15,2	11,0	5,4	0,25	0,2	D16	

Bestellbeispiel // Order example: **D08.1846.02 YR X800** (R = Rechte Ausführung // Right hand version, X800 = Schneidstoff // Grade)

Ausdrehen mit spezieller Spantreppe

Mit optimierter Spanbildung durch spezielle Spantreppe.
Geeignet für Bohrungsdurchmesser 7,8 mm.

Boring with special chip former

Special chip former for improved chip control.
For use in bores of minimum bore diameter 7,8 mm.

Schnittwerte (Start) // Cutting parameters (start)

f	Vc
0,02 mm/U	Seite/Page 429

Passende Klemmhalter auf Seite // Suitable toolholders on page
154, 155, 156, 157, 161, 163, 164

SP

HM

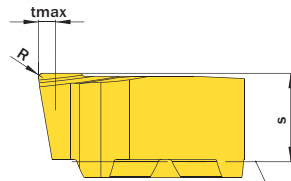
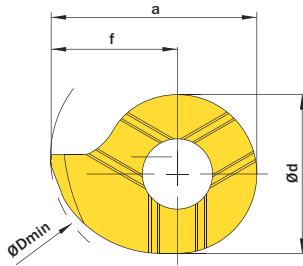
R

Legende
Legend

213

Scan
QR-Code

Oder besuchen Sie // Or Visit
www.simtek.info/cp/858



Stirnseite Klemmhalter
Toolholder face

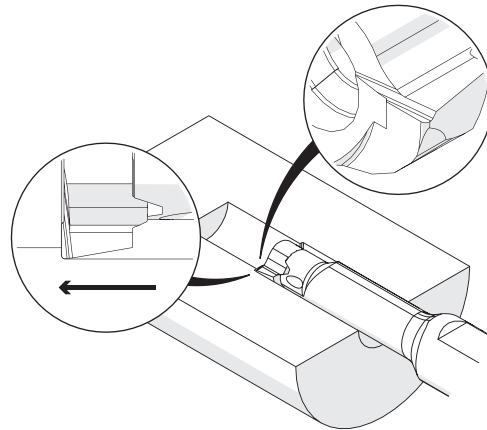


Abbildung zeigt / Drawing shows: D10.0056.02.10 YER R

ØDmin (Min. Bohrung) ØDmin (min. bore)	f	R	Artikelnummer Part number	Webcode www.simtek.com/webcode	Unsere erste Wahl Our first choice	a	Ød	S	tmax	Connectcode www.simtek.com/code
mm	mm	mm			P K M N S	mm	mm	mm	mm	
▼ ØDmin (Min. Bohrung) // ØDmin (min. bore) = 7,8 mm										
7,8	4,65	0,2	D08.0046.02.08 YER/L	R AZC9 L AZDA	X800 X400	7,65	6,0	3,5	0,5	D08
▼ ØDmin (Min. Bohrung) // ØDmin (min. bore) = 9,0 mm										
9,0	5,5	0,2	D09.0055.02.09 YER/L	R AWF8 L AWHN	X800 X400	8,6	6,2	3,6	0,5	D09
▼ ØDmin (Min. Bohrung) // ØDmin (min. bore) = 10,0 mm										
10,0	5,6	0,2	D10.0056.02.10 YER/L	R ATU1 L ATØF	X800 X400	9,1	7,0	3,9	0,75	D10
▼ ØDmin (Min. Bohrung) // ØDmin (min. bore) = 11,0 mm										
11,0	6,7	0,2	D11.0067.02.11 YER/L	R AZC7 L AZC8	X800 X400	10,7	8,0	4,2	0,5	D11

Bestellbeispiel // Order example: **D10.0056.02.10 YER X800** (R = Rechte Ausführung // Right hand version, X800 = Schneidstoff // Grade)

Ausdrehen, Hartbearbeitung

In Verbindung mit einem SIMTEK-CBN-Schneidstoff besonders geeignet für die Hartbearbeitung ab Bohrungsdurchmesser 7,8 mm.

Boring, Hard Part Turning

First choice for hard part turning applications in bores as of bore diameter 7,8 mm in combination with SIMTEK CBN grades.

Schnittwerte (Start) // Cutting parameters (start)

f	Vc
0,02 mm/U	Seite/Page 429

Passende Klemmhalter auf Seite // Suitable toolholders on page

154, 156, 157, 158, 159, 161, 163, 164



SP
CBN HM R

Legende
Legend 213

Scan
QR-Code

Oder besuchen Sie // Or Visit
www.simtek.info/cp/817

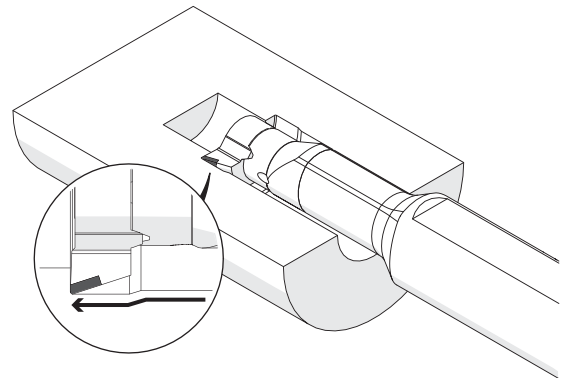
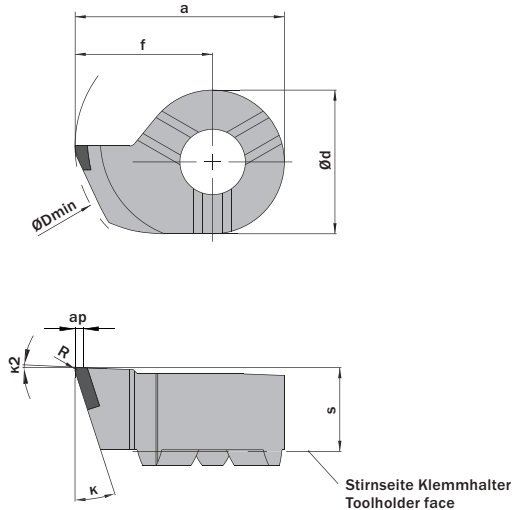


Abbildung zeigt / Drawing shows: D14.1887.02 YU R

ØDmin (Min. Bohrung) ØDmin (min. bore)	κ	κ2	f	R	Artikelnummer Part number	Webcode www.simtek.com/webcode	Unsere erste Wahl Our first choice	P	a	ap	Ød	S	Connectcode www.simtek.com/code
▼ ØDmin (Min. Bohrung) // ØDmin (min. bore) = 7,8 mm													
7,8	18°	8°	4,65	0,2	D08.1846.02 YU R/L	R APDT L ABXT	CBN/GT91		7,65	0,5	6,0	3,5	D08
▼ ØDmin (Min. Bohrung) // ØDmin (min. bore) = 9,8 mm													
9,8	18°	8°	5,5	0,2	D11.1855.02 YU R/L	R ACNP L ADXH	CBN/GT91		9,5	0,5	8,0	4,2	D11
▼ ØDmin (Min. Bohrung) // ØDmin (min. bore) = 10,0 mm													
10,0	18°	8°	5,6	0,2	D10.1856.02.10 YU R/L	R AJE7 L AAT1	CBN/GT91		9,1	0,5	7,0	3,9	D10
▼ ØDmin (Min. Bohrung) // ØDmin (min. bore) = 11,0 mm													
11,0	18°	8°	6,7	0,2	D11.1867.02 YU R/L	R ABKZ L AEFH	CBN/GT91		10,7	0,5	8,0	4,1	D11
▼ ØDmin (Min. Bohrung) // ØDmin (min. bore) = 13,8 mm													
13,8	18°	8°	8,7	0,2	D14.1887.02 YU R/L	R AE3B L APK7	CBN/GT91		13,2	0,5	9,0	5,3	D14
▼ ØDmin (Min. Bohrung) // ØDmin (min. bore) = 15,5 mm													
15,5	18°	8°	9,7	0,2	D16.1897.02 YU R/L	R AACG L AGZM	CBN/GT91		15,2	0,5	11,0	5,4	D16

Bestellbeispiel // Order example: **D10.1856.02.10 YU R CBN8** (R = Rechte Ausführung // Right hand version, CBN8 = Schneidstoff // Grade)

Kopieren / Profildrehen mit 32°

Geeignet ab Bohrungsdurchmesser 7,0 mm.

Copying / Profiling with 32°


For use in bores as of minimum bore diameter 7,0 mm.

Schnittwerte (Start) // Cutting parameters (start)

f **0,02 mm/U** Vc **Seite/Page 429**

Passende Klemmhalter auf Seite // Suitable toolholders on page

153, 154, 155, 156, 157, 158, 159, 161, 162, 163, 164



SP HM R Legende Legend **213**
Scan QR-Code Oder besuchen Sie // Or Visit www.simtek.info/cp/1336

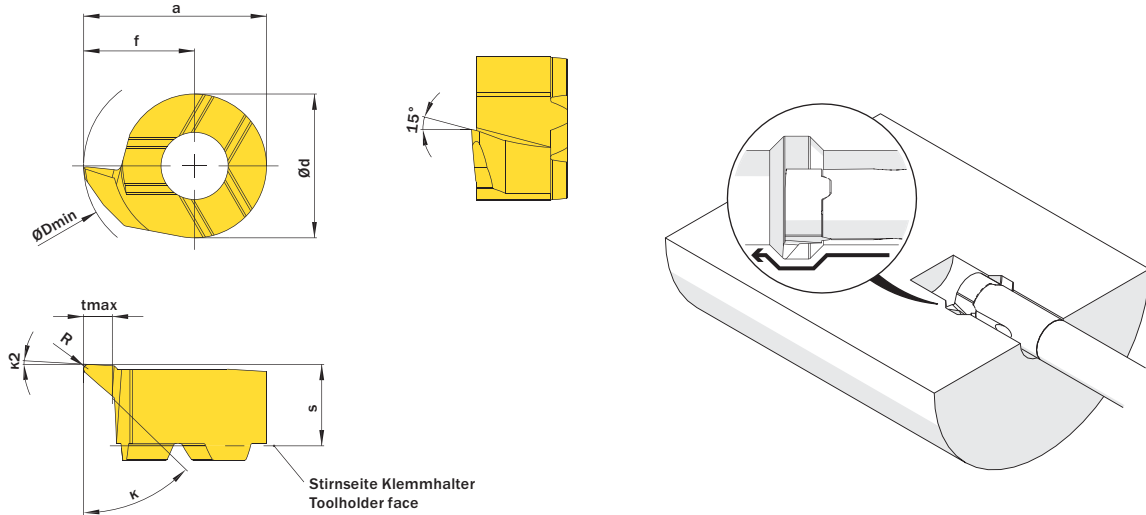


Abbildung zeigt / Drawing shows: D08.4746.02 YR

ØDmin (Min. Bohrung) ØDmin (min. bore)	κ	κ2	f	R	Artikelnummer Part number	Webcode www.simtek.com/webcode	Unsere erste Wahl Our first choice	a	Ød	S	tmax	Connectcode www.simtek.com/code	
mm			mm	mm			P K M N S	mm	mm	mm	mm		
▼ ØDmin (Min. Bohrung) // ØDmin (min. bore) = 7,0 mm													
7,0	32°	3°	4,15	0,2	D07.3246.02 YR	A51B	x800 x400	6,55	4,8	3,5	1,2	D07	new
▼ ØDmin (Min. Bohrung) // ØDmin (min. bore) = 7,8 mm													
7,8	30°	5°	4,65	0,2	D08.2555.02 YR/L	R ADG0 L AFB6	x800 x400	7,65	6,0	3,5	1,0	D08	
7,8	32°	5°	4,65	0,4	D08.3246.04 YR	A51F	x800 x400	7,65	6,0	3,5	1,0	D08	new
▼ ØDmin (Min. Bohrung) // ØDmin (min. bore) = 9,0 mm													
9,0	32°	3°	5,5	0,2	D09.3255.02.09 YR	A51H	x800 x400	8,6	6,2	3,6	1,5	D09	new
▼ ØDmin (Min. Bohrung) // ØDmin (min. bore) = 10,0 mm													
10,0	32°	3°	5,8	0,2	D10.3258.02.10 YR	A51K	x800 x400	9,3	7,0	3,9	1,8	D10	new
▼ ØDmin (Min. Bohrung) // ØDmin (min. bore) = 11,0 mm													
11,0	30°	5°	6,7	0,2	D11.2755.02 YR/L	R AJ32 L AJHE	x800 x400	10,7	8,0	4,2	2,3	D11	
11,0	32°	5°	6,7	0,4	D11.3267.04 YR	A51N	x800 x400	10,7	8,0	4,2	2,3	D11	new
▼ ØDmin (Min. Bohrung) // ØDmin (min. bore) = 13,7 mm													
13,7	32°	5°	8,7	0,4	D14.3287.04 YR	A51Q	x800 x400	13,2	9,0	5,3	4,0	D14	new
13,7	30°	5°	8,7	0,2	D14.3555.02 YR/L	R ABCT L AACN	x800 x400	13,2	9,0	5,3	4,0	D14	
▼ ØDmin (Min. Bohrung) // ØDmin (min. bore) = 15,8 mm													
15,8	30°	5°	10,2	0,2	D16.4055.02 YR/L	R AJWM L AK73	x800 x400	15,7	11,0	5,4	4,3	D16	
▼ ØDmin (Min. Bohrung) // ØDmin (min. bore) = 16,0 mm													
16,0	32°	5°	11,0	0,2	D14.3210.02.16 YR	A51T	x800 x400	15,5	9,0	5,2	5,0	D14	new

Bestellbeispiel // Order example: **D08.2555.02 YR X800** (R = Rechte Ausführung // Right hand version, X800 = Schneidstoff // Grade)

simturn AX
simturn DX
simturn PX
simturn H2
simturn K2
simturn C4
simturn GX
simturn E3
simturn E12
simturn FX
simturn Decolletage
simturn OA
Index

Kopieren / Profildrehen mit 47°

Geeignet ab Bohrungsdurchmesser 7,0 mm.

Copying / Profiling with 47°

For use in bores as of minimum bore diameter 7,0 mm.

Schnittwerte (Start) // Cutting parameters (start)

f **0,02 mm/U** Vc **Seite/Page 429**

Passende Klemmhalter auf Seite // Suitable toolholders on page

153, 154, 155, 156, 157, 158, 159, 160, 161, 162, 163, 164



Legende **213**
Legend

Scan QR-Code

Oder besuchen Sie // Or Visit www.simtek.info/cp/814

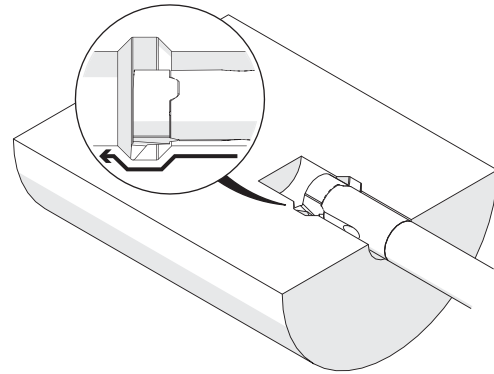
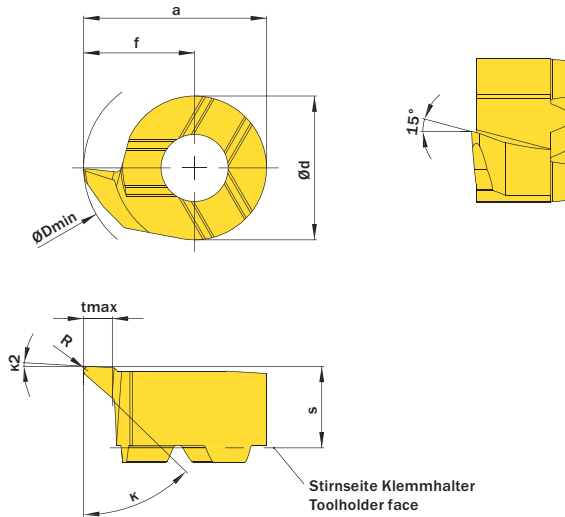


Abbildung zeigt / Drawing shows: D08.4746.02 Y R

ØDmin (Min. Bohrung) ØDmin (min. bore)	κ	κ2	f	R	Artikelnummer Part number	Webcode www.simtek.com/webcode	Unsere erste Wahl Our first choice				a	Ød	S	tmax	Connectcode www.simtek.com/code
							P	K	M	S					
▼ ØDmin (Min. Bohrung) // ØDmin (min. bore) = 7,0 mm															
7,0	47°	3°	4,15	0,2	D07.4746.02 YR/L	R AVQU L AXBB	X800	X400		6,55	4,8	3,7	1,2	D07	
▼ ØDmin (Min. Bohrung) // ØDmin (min. bore) = 7,8 mm															
7,8	47°	3°	4,65	0,1	D08.4746.01 YR/L	R AX66 L AX67	X800	X400		7,65	6,0	3,5	1,2	D08	
7,8	47°	3°	4,65	0,2	D08.4746.02 YR/L	R AKYF L AJ2X	X800	X400		7,65	6,0	3,5	1,2	D08	
7,8	47°	3°	4,65	0,4	D08.4746.04 YR/L	R AS6C L AS6D	X800	X400		7,65	6,0	3,5	1,2	D08	
▼ ØDmin (Min. Bohrung) // ØDmin (min. bore) = 9,0 mm															
9,0	47°	3°	5,5	0,2	D09.4755.02.09 YR/L	R AWGJ L AWHZ	X800	X400		8,6	6,2	3,6	1,5	D09	
▼ ØDmin (Min. Bohrung) // ØDmin (min. bore) = 10,0 mm															
10,0	47°	3°	5,8	0,2	D10.4758.02.10 YR/L	R AD29 L AJQD	X800	X400		9,3	7,0	3,9	1,8	D10	
▼ ØDmin (Min. Bohrung) // ØDmin (min. bore) = 11,0 mm															
11,0	47°	3°	6,7	0,2	D11.4767.02 YR/L	R AENC L AA5D	X800	X400		10,7	8,0	4,2	2,3	D11	
11,0	47°	3°	6,7	0,4	D11.4767.04 YR	A232	X800	X400		10,7	8,0	4,2	2,3	D11	
▼ ØDmin (Min. Bohrung) // ØDmin (min. bore) = 13,7 mm															
13,7	47°	3°	8,7	0,2	D14.4787.02 YR/L	R AB9M L ACMV	X800	X400		13,2	9,0	5,3	4,0	D14	
13,7	47°	3°	8,7	0,4	D14.4787.04 YR	A233	X800	X400		13,2	9,0	5,3	4,0	D14	
▼ ØDmin (Min. Bohrung) // ØDmin (min. bore) = 15,8 mm															
15,8	47°	3°	10,2	0,2	D16.4702.02 YR/L	R AEPV L APDF	X800	X400		15,7	11,0	5,4	4,3	D16	
▼ ØDmin (Min. Bohrung) // ØDmin (min. bore) = 16,0 mm															
16,0	47°	3°	11,0	0,2	D14.4710.02 YR/L	R ANK4 L AAN6	X800	X400		15,5	9,0	5,2	5,0	D14	
▼ ØDmin (Min. Bohrung) // ØDmin (min. bore) = 18,0 mm															
18,0	47°	3°	12,0	0,2	D18.4712.02.18 YR/L	R ADMT L ANKX	X800	X400		17,5	11,0	5,6	6,0	D18	
▼ ØDmin (Min. Bohrung) // ØDmin (min. bore) = 20,0 mm															
20,0	47°	3°	14,0	0,2	D18.4714.02.20 YR/L	R AE0B L ABFF	X800	X400		19,5	11,0	5,6	8,0	D18	

Bestellbeispiel // Order example: **D09.4755.02.09 YR X800** (R = Rechte Ausführung // Right hand version, X800 = Schneidstoff // Grade)

Ausdrehen und Fasen

Geeignet ab Bohrungsdurchmesser 7,0 mm.

Boring and Chamfering

For use in bores as of minimum bore diameter 7,0 mm.

Schnittwerte (Start) // Cutting parameters (start)

f **0,02 mm/U** Vc **Seite/Page 429**

Passende Klemmhalter auf Seite // Suitable toolholders on page

153, 154, 155, 156, 157, 158, 161, 162, 163, 164



SP **HM** **R** **Legende Legend 213**
Scan QR-Code Oder besuchen Sie // Or Visit www.simtek.info/cp/816

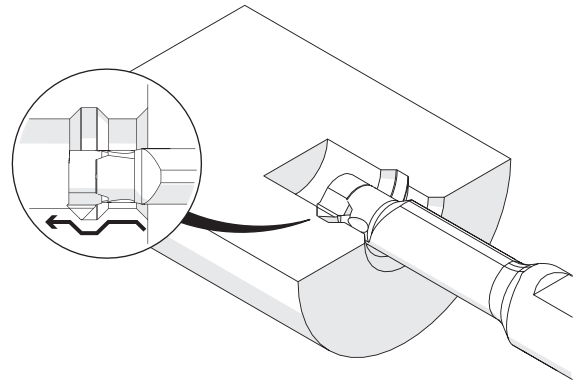
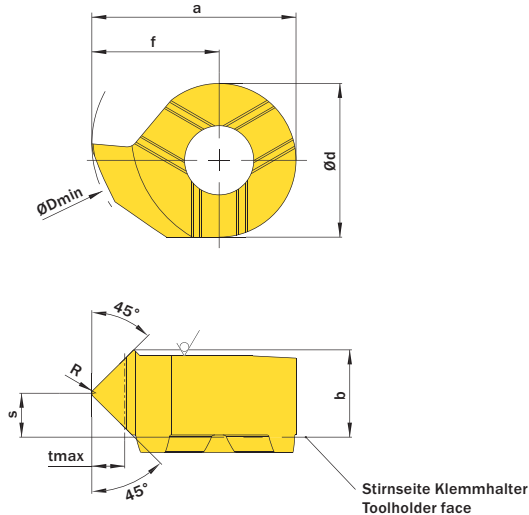


Abbildung zeigt / Drawing shows: D10.4545.02.10 F R

R	Artikelnummer Part number	Webcode www.simtek.com/webcode	Unsere erste Wahl Our first choice	a	b	Ød	ØDmin (Min. Bohrung) ØDmin (min. bore)	f	s	tmax	Connectcode www.simtek.com/code
mm			P K M N S	mm	mm	mm	mm	mm	mm	mm	
▼ ØDmin (Min. Bohrung) // ØDmin (min. bore) = 7,0 mm											
0,2	D07.4545.02.07 FR/L	R AU56	L AXBA X800 X400	6,6	3,7	4,8	7,0	4,2	2,3	0,8	D07
▼ ØDmin (Min. Bohrung) // ØDmin (min. bore) = 8,0 mm											
0,2	D08.4545.02 FR/L	R APXW	L AC28 X800 X400	7,8	3,2	6,0	8,0	4,8	1,6	1,4	D08
▼ ØDmin (Min. Bohrung) // ØDmin (min. bore) = 9,0 mm											
0,2	D09.4545.02.09 FR/L	R AWGH	L AWHY X800 X400	8,6	3,55	6,2	9,0	5,5	1,8	1,3	D09
▼ ØDmin (Min. Bohrung) // ØDmin (min. bore) = 10,0 mm											
0,2	D10.4545.02.10 FR/L	R ACF9	L AAY2 X800 X400	9,3	4,0	7,0	10,0	5,8	2,0	1,5	D10
▼ ØDmin (Min. Bohrung) // ØDmin (min. bore) = 11,0 mm											
0,2	D11.4545.02 FR/L	R AM16	L ACDY X800 X400	10,7	4,3	8,0	11,0	6,7	2,2	1,5	D11
▼ ØDmin (Min. Bohrung) // ØDmin (min. bore) = 14,0 mm											
0,2	D14.4545.02 FR/L	R AKCK	L AM8J X800 X400	13,5	5,35	9,0	14,0	9,0	2,7	1,5	D14

Bestellbeispiel // Order example: **D14.4545.02 FR X800** (R = Rechte Ausführung // Right hand version, X800 = Schneidstoff // Grade)

Rückwärtsdrehen

Geeignet ab Bohrungsdurchmesser 7,8 mm.

Back Boring

For use in bores as of minimum bore diameter 7,8 mm.

Schnittwerte (Start) // Cutting parameters (start)

f	Vc
0,02 mm/U	Seite/Page 429

Passende Klemmhalter auf Seite // Suitable toolholders on page

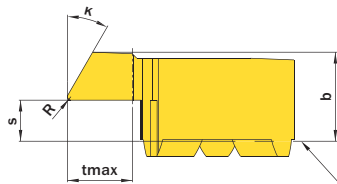
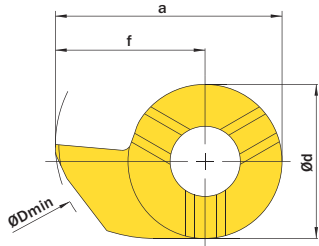
154, 155, 156, 157, 158, 160, 161, 163, 164



Legende
Legend 213



Oder besuchen Sie // Or Visit
www.simtek.info/cp/828



Stirnseite Klemmhalter
Toolholder face

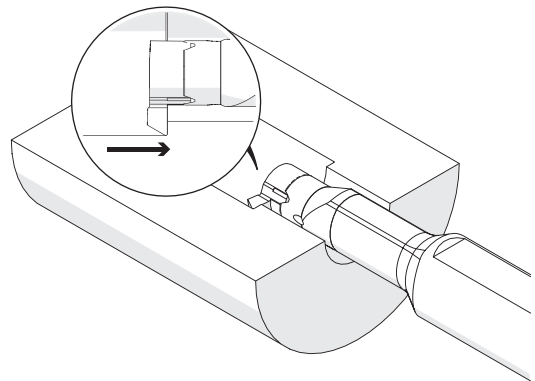
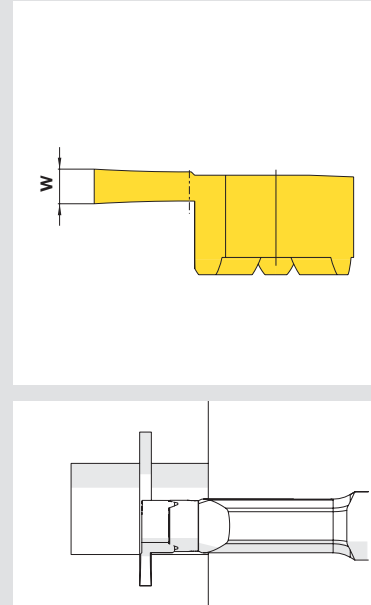
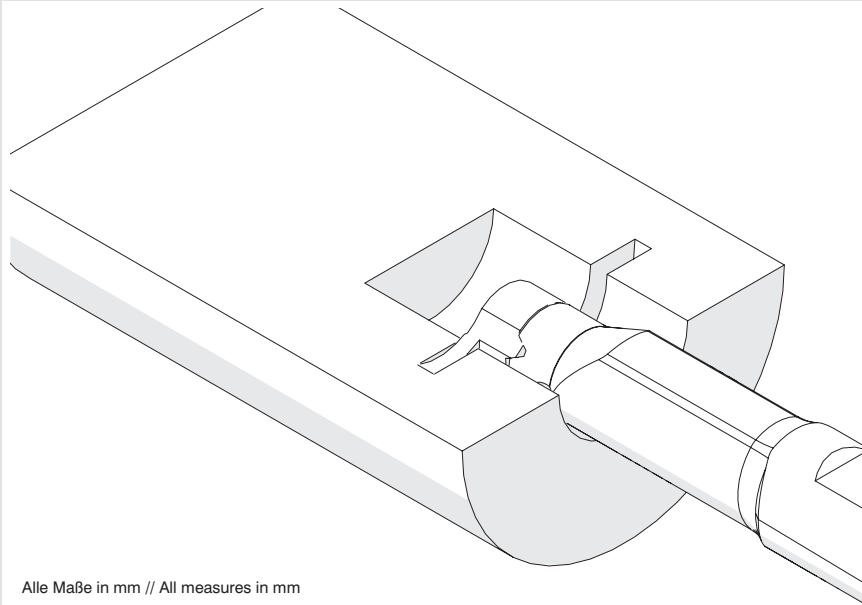


Abbildung zeigt / Drawing shows: D14.3087.02 Y R

K	f mm	R mm	Artikelnummer Part number	Webcode www.simtek.com/webcode	Unsere erste Wahl Our first choice				a mm	b mm	Ød mm	ØDmin (Min. Bohrung) ØDmin (min. bore) mm	s mm	tmax mm	Connectcode www.simtek.com/code
					P	K	M	S							
▼ ØDmin (Min. Bohrung) // ØDmin (min. bore) = 7,8 mm															
30°	4,65	0,2	D08.3046.02 YR/L	R AB86 L AHJF	X800	X400			7,65	3,34	6,0	7,8	1,0	1,3	D08
▼ ØDmin (Min. Bohrung) // ØDmin (min. bore) = 9,0 mm															
30°	5,5	0,2	D09.3055.02.09 YR/L	R AWF6 L AWHK	X800	X400			8,6	3,65	6,2	9,0	1,2	1,7	D09
▼ ØDmin (Min. Bohrung) // ØDmin (min. bore) = 10,0 mm															
30°	6,5	0,2	D09.3065.02.10 YR/L	R AWF7 L AWHM	X800	X400			9,6	3,69	6,2	10,0	1,2	2,3	D09
30°	5,8	0,2	D10.3058.02.10 YR/L	R ACSJ L ANMJ	X800	X400			9,3	3,95	7,0	10,0	1,3	2,0	D10
▼ ØDmin (Min. Bohrung) // ØDmin (min. bore) = 11,0 mm															
30°	6,8	0,2	D10.3068.02.11 YR/L	R AJPW L AN7H	X800	X400			10,3	4,0	7,0	11,0	1,3	2,6	D10
30°	6,7	0,2	D11.3067.02 YR/L	R AJØS L AKZX	X800	X400			10,7	4,3	8,0	11,0	1,6	2,3	D11
▼ ØDmin (Min. Bohrung) // ØDmin (min. bore) = 13,8 mm															
30°	8,7	0,2	D14.3087.02 YR/L	R AGJN L AG8E	X800	X400			13,2	5,4	9,0	13,8	2,4	3,5	D14
▼ ØDmin (Min. Bohrung) // ØDmin (min. bore) = 20,0 mm															
30°	14,0	0,2	D18.3014.02.20 YR/L	R AWDS L AWDQ	X800	X400			19,5	5,7	11,0	20,0	1,6	8,0	D18

Bestellbeispiel // Order example: **D14.3087.02 YR X800** (R = Rechte Ausführung // Right hand version, X800 = Schneidstoff // Grade)

Nutenstechen Grooving



Alle Maße in mm // All measures in mm

Artikelnummer Part number	ØDmin (Min. Bohrung) ØDmin (min. bore)	w	Nuttbreite Nominal width of groove	siehe Seite see Page
D07.0100.00.07 GR/L	7,0	1,0	-	176
D07.0150.00.07 GR/L	7,0	1,5	-	176
D07.0100.00.08 GR/L	7,8	1,0	-	176
D07.0150.00.08 GR/L	7,8	1,5	-	176
D08.0070.00 ZR/L	8,0	0,73	0,7	177
D08.0078.00 GR/L	8,0	0,787	-	177
D08.0080.00 ZR/L	8,0	0,83	0,8	177
D08.0090.00 ZR/L	8,0	0,93	0,9	177
D08.0100.00 GR/L	8,0	1,0	-	177
D08.0110.00 GR/L	8,0	1,2	1,1	177
D08.0130.00 GR/L	8,0	1,4	1,3	177
D08.0150.00 GR/L	8,0	1,5	-	177
D08.0157.00 GR/L	8,0	1,575	-	177
D08.0160.00 GR/L	8,0	1,7	1,6	177
D08.0198.00 GR/L	8,0	1,981	-	177
D08.0200.00 GR/L	8,0	2,0	-	177
D09.0070.00.09 GR/L	9,0	0,73	0,7	178
D09.0080.00.09 GR/L	9,0	0,83	0,8	178
D09.0090.00.09 GR/L	9,0	0,93	0,9	178
D09.0100.00.09 GR/L	9,0	1,0	-	178
D09.0110.00.09 GR/L	9,0	1,2	1,1	178
D09.0130.00.09 GR/L	9,0	1,4	1,3	178
D09.0150.00.09 GR/L	9,0	1,5	-	178
D09.0160.00.09 GR/L	9,0	1,7	1,6	178
D09.0200.00.09 GR/L	9,0	2,0	-	178
D09.0250.00.09 GR/L	9,0	2,5	-	178
D09.0300.00.09 GR/L	9,0	3,0	-	178
D10.0070.00.10 GR/L	10,0	0,73	0,7	179
D10.0080.00.10 GR/L	10,0	0,83	0,8	179
D10.0090.00.10 GR/L	10,0	0,93	0,9	179
D10.0100.00.10 GR/L	10,0	1,0	-	179
D10.0110.00.10 GR/L	10,0	1,2	1,1	179
D10.0130.00.10 GR/L	10,0	1,4	1,3	179
D10.0150.00.10 GR/L	10,0	1,5	-	179
D10.0160.00.10 GR/L	10,0	1,7	1,6	179
D10.0200.00.10 GR/L	10,0	2,0	-	179
D10.0238.00.10 GR/L	10,0	2,388	-	179
D10.0250.00.10 GR/L	10,0	2,5	-	179
D10.0300.00.10 GR/L	10,0	3,0	-	179
D10.0318.00.10 GR/L	10,0	3,175	-	179
D11.0070.00 ZR/L	11,0	0,73	0,7	181

Artikelnummer Part number	ØDmin (Min. Bohrung) ØDmin (min. bore)	w	Nuttbreite Nominal width of groove	siehe Seite see Page
D11.0078.00 ZR/L	11,0	0,787	-	181
D11.0080.00 ZR/L	11,0	0,83	0,8	181
D11.0090.00 ZR/L	11,0	0,93	0,9	181
D10.0100.00.11 GR/L	11,0	1,0	-	180
D11.0100.00 GR/L	11,0	1,0	-	181
D11.0110.00 GR/L	11,0	1,2	1,1	181
D11.0130.00 GR/L	11,0	1,4	1,3	181
D10.0150.00.11 GR/L	11,0	1,5	-	180
D11.0150.00 GR/L	11,0	1,5	-	181
D11.0157.00 GR/L	11,0	1,575	-	181
D11.0160.00 GR/L	11,0	1,7	1,6	181
D10.0200.00.11 GR/L	11,0	2,0	-	180
D11.0200.00 GR/L	11,0	2,0	-	181
D10.0238.00.11 GR/L	11,0	2,388	-	180
D11.0238.00 GR/L	11,0	2,388	-	181
D10.0250.00.11 GR/L	11,0	2,5	-	180
D11.0250.00 GR/L	11,0	2,5	-	181
D10.0300.00.11 GR/L	11,0	3,0	-	180
D11.0300.00 GR/L	11,0	3,0	-	181
D10.0318.00.11 GR/L	11,0	3,175	-	180
D11.0318.00 GR/L	11,0	3,175	-	181
D10.0100.00.12 GR/L	12,0	1,0	-	182
D10.0150.00.12 GR/L	12,0	1,5	-	182
D10.0200.00.12 GR/L	12,0	2,0	-	182
D14.0070.00 ZR/L	14,0	0,73	0,7	183
D14.0078.00 ZR/L	14,0	0,787	-	183
D14.0080.00 ZR/L	14,0	0,83	0,8	183
D14.0086.00 ZR/L	14,0	0,86	-	183
D14.0090.00 ZR/L	14,0	0,93	0,9	183
D14.0100.00 ZR/L	14,0	1,0	-	183
D14.0110.00 GR/L	14,0	1,2	1,1	183
D14.0130.00 GR/L	14,0	1,4	1,3	183
D14.0150.00 GR/L	14,0	1,5	-	183
D14.0157.00 GR/L	14,0	1,575	-	183
D14.0160.00 GR/L	14,0	1,7	1,6	183
D14.0200.00 GR/L	14,0	2,0	-	183
D14.0238.00 GR/L	14,0	2,388	-	183
D14.0250.00 GR/L	14,0	2,5	-	183
D14.0300.00 GR/L	14,0	3,0	-	183
D14.0318.00 GR/L	14,0	3,175	-	183
D16.0070.00 ZR/L	16,0	0,73	0,7	185

Artikelnummer Part number	ØDmin (Min. Bohrung) ØDmin (min. bore)	w	Nuttbreite Nominal width of groove	siehe Seite see Page
D16.0078.00 ZR/L	16,0	0,787	-	185
D16.0080.00 ZR/L	16,0	0,83	0,8	185
D16.0090.00 ZR/L	16,0	0,93	0,9	185
D16.0100.00 ZR/L	16,0	1,0	1,0	185
D16.0110.00 GR/L	16,0	1,2	1,1	185
D16.0130.00 GR/L	16,0	1,4	1,3	185
D14.0150.00.16 GR/L	16,0	1,5	-	184
D16.0150.00 GR/L	16,0	1,5	-	185
D16.0157.00 GR/L	16,0	1,575	-	185
D16.0160.00 GR/L	16,0	1,7	1,6	185
D14.0200.00.16 GR/L	16,0	2,0	-	184
D16.0200.00 GR/L	16,0	2,0	-	185
D14.0250.00.16 GR/L	16,0	2,5	-	184
D16.0250.00 GR/L	16,0	2,5	-	185
D14.0300.00.16 GR/L	16,0	3,0	-	184
D16.0300.00 GR/L	16,0	3,0	-	185
D16.0350.00 GR/L	16,0	3,5	-	185
D16.0400.00 GR/L	16,0	4,0	-	185
D14.0150.00.17 GR/L	17,0	1,5	-	186
D14.0200.00.17 GR/L	17,0	2,0	-	186
D14.0250.00.17 GR/L	17,0	2,5	-	186
D14.0300.00.17 GR/L	17,0	3,0	-	186
D18.0150.00.18 GR/L	18,0	1,5	-	187
D18.0200.00.18 GR/L	18,0	2,0	-	187
D18.0238.00.18 GR/L	18,0	2,388	-	187
D18.0250.00.18 GR/L	18,0	2,5	-	187
D18.0300.00.18 GR/L	18,0	3,0	-	187
D18.0350.00.18 GR/L	18,0	3,5	-	187
D18.0400.00.18 GR/L	18,0	4,0	-	187
D18.0150.00.20 GR/L	20,0	1,5	-	188
D18.0200.00.20 GR/L	20,0	2,0	-	188
D18.0238.00.20 GR/L	20,0	2,388	-	188
D18.0250.00.20 GR/L	20,0	2,5	-	188
D18.0300.00.20 GR/L	20,0	3,0	-	188
D18.0350.00.20 GR/L	20,0	3,5	-	188
D18.0400.00.20 GR/L	20,0	4,0	-	188

Nutenstechen

Für allgemeines Nutenstechen und für Sicherungsringnuten.
Geeignet ab Bohrungsdurchmesser 7,0 mm.

Grooving

For general grooving as well as for circlip ring grooving.
For use in bores as of minimum bore diameter 7,0 mm.

Schnittwerte (Start) // Cutting parameters (start)

f	Vc
0,02 mm/U	Seite/Page 429

Passende Klemmhalter auf Seite // Suitable toolholders on page
153, 162, 164

Vergleichbare Werkzeuge auf Seite // Similar tools on page
175

SP

HM

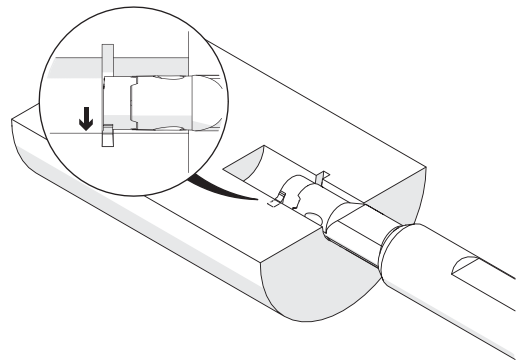
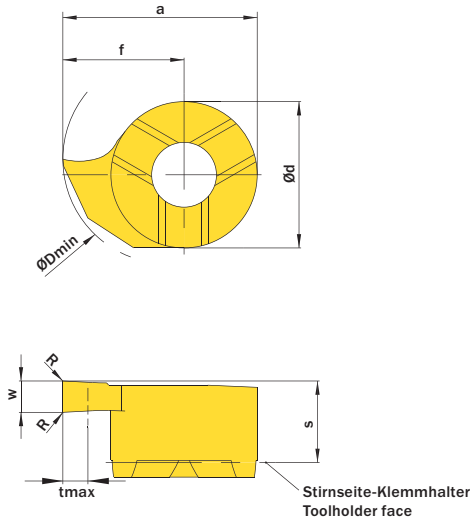
R

Legende
Legend

213

Scan
QR-Code

Oder besuchen Sie // Or Visit
www.simtek.info/cp/965



w ^{+0,03}	Nutnenbreite Nominal width of groove	ØDmin (Min. Bohrung) ØDmin (min. bore)	Artikelnummer Part number	Webcode www.simtek.com/webcode	Unsere erste Wahl Our first choice	a	Ød	f	R	S	tmax	Connectcode www.simtek.com/ccode
mm	mm	mm			P K M N S	mm	mm	mm	mm	mm	mm	
▼ ØDmin (Min. Bohrung) // ØDmin (min. bore) = 7,0 mm												
1,0	-	7,0	D07.0100.00.07 GR/L	R AU52 L AXA3	X800 X400	6,6	4,8	4,2	-	3,7	1,0	D07
1,5	-	7,0	D07.0150.00.07 GR/L	R AU53 L AXA5	X800 X400	6,6	4,8	4,2	-	3,7	1,0	D07
▼ ØDmin (Min. Bohrung) // ØDmin (min. bore) = 7,8 mm												
1,0	-	7,8	D07.0100.00.08 GR/L	R AU54 L AXA4	X800 X400	7,6	4,8	5,2	-	3,7	2,0	D07
1,5	-	7,8	D07.0150.00.08 GR/L	R AU55 L AXA6	X800 X400	7,6	4,8	5,2	-	3,7	2,0	D07

Verwandte Werkzeuge finden Sie auch auf der folgenden Seite!
Related Items can be found on the following page as well!

Fortgesetzte Tabelle
Continued Table

Bestellbeispiel // Order example: **D07.0150.00.08 GR X800** (R = Rechte Ausführung // Right hand version, X800 = Schneidstoff // Grade)

D07. w, 1/100 mm, 4 Stellen/Digits . R, 1/100 mm, 3 Stellen/Digits .07 Toleranz // Tolerance R

Beispielartikelnummer // Example Part number: **D07.0156.015.07 XG R**

D07. w, 1/100 mm, 4 Stellen/Digits . R, 1/100 mm, 3 Stellen/Digits .08 Toleranz // Tolerance R

Beispielartikelnummer // Example Part number: **D07.0156.015.08 XG R**

Nutenstechen

Für allgemeines Nutenstechen und für Sicherungsringnuten.
Geeignet ab Bohrungsdurchmesser 8,0 mm.

Grooving

For general grooving as well as for circlip ring grooving.
For use in bores as of minimum bore diameter 8,0 mm.

Schnittwerte (Start) // Cutting parameters (start)	
f 0,02 mm/U	Vc Seite/Page 429

Passende Klemmhalter auf Seite // Suitable toolholders on page 154, 163

Vergleichbare Werkzeuge auf Seite // Similar tools on page 175
--

SP

HM

R

Legende
Legend **213**

Scan
QR-Code

Oder besuchen Sie // Or Visit
www.simtek.info/cp/829

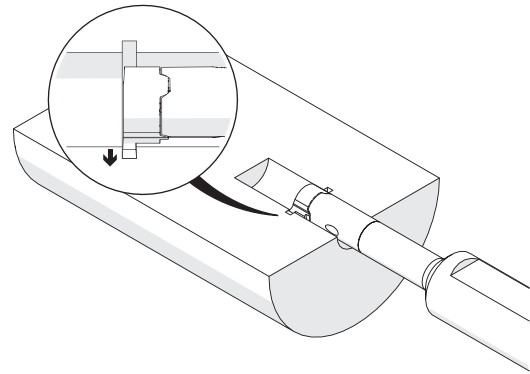
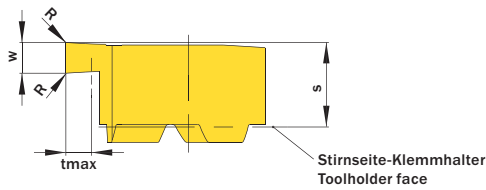
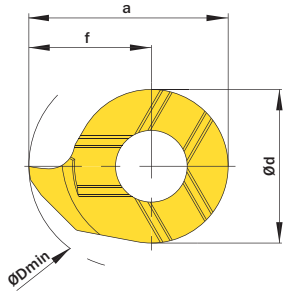


Abbildung zeigt / Drawing shows: D08.0110.00 G R

w ^{+0,03}	Nutnenbreite Nominal width of groove	ØDmin (Min. Bohrung) ØDmin (min. bore)	Artikelnummer Part number	Webcode www.simtek.com/webcode	Unsere erste Wahl Our first choice	a	Ød	f	R	S	tmax	Connectcode www.simtek.com/code
mm	mm	mm		www.simtek.com/webcode	P K M N S	mm	mm	mm	mm	mm	mm	www.simtek.com/code

◀ Fortgesetzte Tabelle Continued Table Verwandte Werkzeuge finden Sie auch auf der vorhergehenden Seite!
Related items can be found on the previous page as well!

0,73	0,7	8,0	D08.0070.00 ZR/L	R AB9U L ADBZ X800 X400	7,8	6,0	4,8	-	3,3	1,0	D08	
0,787	-	8,0	D08.0078.00 GR/L	R ANEN L AH0A X800 X400	7,8	6,0	4,8	-	3,3	1,0	D08	inch
0,83	0,8	8,0	D08.0080.00 ZR/L	R AKJ6 L AMGG X800 X400	7,8	6,0	4,8	-	3,3	1,0	D08	
0,93	0,9	8,0	D08.0090.00 ZR/L	R AN56 L AMYN X800 X400	7,8	6,0	4,8	-	3,3	1,0	D08	
1,0	-	8,0	D08.0100.00 GR/L	R AKUA L AGCE X800 X400	7,8	6,0	4,8	-	3,3	1,0	D08	
1,2	1,1	8,0	D08.0110.00 GR/L	R ABPM L ANT9 X800 X400	7,8	6,0	4,8	-	3,3	1,0	D08	
1,4	1,3	8,0	D08.0130.00 GR/L	R AMN4 L AG33 X800 X400	7,8	6,0	4,8	-	3,3	1,0	D08	
1,5	-	8,0	D08.0150.00 GR/L	R AK83 L AFKC X800 X400	7,8	6,0	4,8	-	3,3	1,0	D08	
1,575	-	8,0	D08.0157.00 GR/L	R AKYG L AHA1 X800 X400	7,8	6,0	4,8	-	3,3	1,0	D08	inch
1,7	1,6	8,0	D08.0160.00 GR/L	R ACV2 L AGGD X800 X400	7,8	6,0	4,8	-	3,3	1,0	D08	
1,981	-	8,0	D08.0198.00 GR/L	R AE0H L AK8B X800 X400	7,8	6,0	4,8	-	3,3	1,0	D08	new inch
2,0	-	8,0	D08.0200.00 GR/L	R AJB6 L ANSM X800 X400	7,8	6,0	4,8	-	3,3	1,0	D08	

Verwandte Werkzeuge finden Sie auch auf der folgenden Seite!
Related items can be found on the following page as well!

▶ Fortgesetzte Tabelle Continued Table

|| Bestellbeispiel // Order example: **D08.0150.00 GR X800** (R = Rechte Ausführung // Right hand version, X800 = Schneidstoff // Grade)



D08. w, 1/100 mm, 4 Stellen/Digits . R, 1/100 mm, 3 Stellen/Digits Toleranz // Tolerance R/L
Beispielartikelnummer // Example Part number: **D08.0156.015 XN R** oder//or **D08.0156.015 XN L**

Nutenstechen

Für allgemeines Nutenstechen und für Sicherungsringnuten.
Geeignet ab Bohrungsdurchmesser 9,0 mm.

Grooving

For general grooving as well as for circlip ring grooving.
For use in bores as of minimum bore diameter 9,0 mm.

Schnittwerte (Start) // Cutting parameters (start)

f	Vc
0,02 mm/U	Seite/Page 429

Passende Klemmhalter auf Seite // Suitable toolholders on page
155, 164

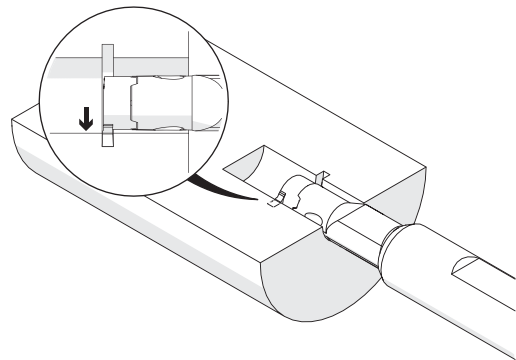
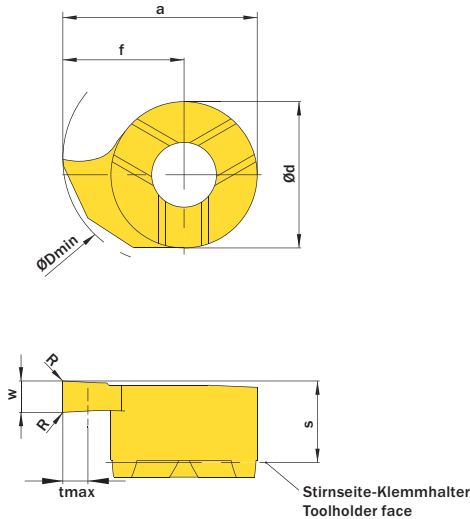
Vergleichbare Werkzeuge auf Seite // Similar tools on page
175



Legende
Legend **213**



Oder besuchen Sie // Or Visit
www.simtek.info/cp/988



w ^{+0,03}	Nutnenbreite Nominal width of groove	ØDmin (Min. Bohrung) ØDmin (min. bore)	Artikelnummer Part number	Webcode www.simtek.com/webcode	Unsere erste Wahl Our first choice	a	Ød	f	R	S	tmax	Connectcode www.simtek.com/ccode
mm	mm	mm			P K M N S	mm	mm	mm	mm	mm	mm	

◀ Fortgesetzte Tabelle
Continued Table

Verwandte Werkzeuge finden Sie auch auf der vorhergehenden Seite!
Related Items can be found on the previous page as well!

0,73	0,7	9,0	D09.0070.00.09 GR/L	R AWF	L AWH	X800 X400	8,6	6,2	5,5	-	3,6	1,2	D09
0,83	0,8	9,0	D09.0080.00.09 GR/L	R AWF	L AWG	X800 X400	8,6	6,2	5,5	-	3,6	1,3	D09
0,93	0,9	9,0	D09.0090.00.09 GR/L	R AWF	L AWG	X800 X400	8,6	6,2	5,5	-	3,6	1,5	D09
1,0	-	9,0	D09.0100.00.09 GR/L	R AWF	L AWG	X800 X400	8,6	6,2	5,5	-	3,6	1,8	D09
1,2	1,1	9,0	D09.0110.00.09 GR/L	R AWF	L AWG	X800 X400	8,6	6,2	5,5	-	3,6	1,8	D09
1,4	1,3	9,0	D09.0130.00.09 GR/L	R AWF	L AWG	X800 X400	8,6	6,2	5,5	-	3,6	1,8	D09
1,5	-	9,0	D09.0150.00.09 GR/L	R AWF	L AWG	X800 X400	8,6	6,2	5,5	-	3,6	1,8	D09
1,7	1,6	9,0	D09.0160.00.09 GR/L	R AWF	L AWG	X800 X400	8,6	6,2	5,5	-	3,6	1,8	D09
2,0	-	9,0	D09.0200.00.09 GR/L	R AWF	L AWG	X800 X400	8,6	6,2	5,5	-	3,6	1,8	D09
2,5	-	9,0	D09.0250.00.09 GR/L	R AWF	L AWG	X800 X400	8,6	6,2	5,5	-	3,6	1,8	D09
3,0	-	9,0	D09.0300.00.09 GR/L	R AWF	L AWG	X800 X400	8,6	6,2	5,5	-	3,6	1,8	D09

Verwandte Werkzeuge finden Sie auch auf der folgenden Seite!
Related Items can be found on the following page as well!

Fortgesetzte Tabelle
Continued Table ▶

Bestellbeispiel // Order example: **D09.0200.00.09 GR X800** (R = Rechte Ausführung // Right hand version, X800 = Schneidstoff // Grade)



D09. w, 1/100 mm, 4 Stellen/Digits . R, 1/100 mm, 3 Stellen/Digits .09 Toleranz // Tolerance R
Beispielartikelnummer // Example Part number: **D09.0156.015.09 XN R**

Nutenstechen

Für allgemeines Nutenstechen und für Sicherungsringnuten.
Geeignet ab Bohrungsdurchmesser 10,0 mm.

Grooving

For general grooving as well as for circlip ring grooving.
For use in bores as of minimum bore diameter 10,0 mm.

Schnittwerte (Start) // Cutting parameters (start)	
f 0,02 mm/U	Vc Seite/Page 429

Passende Klemmhalter auf Seite // Suitable toolholders on page 156, 161, 164
--

Vergleichbare Werkzeuge auf Seite // Similar tools on page 175
--

SP

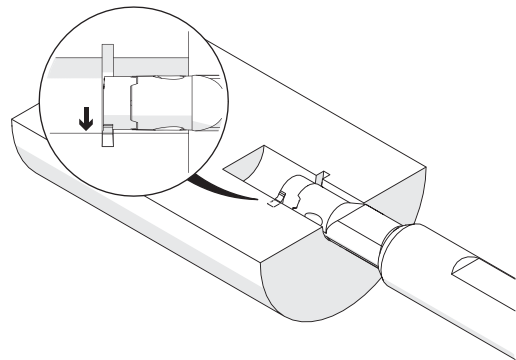
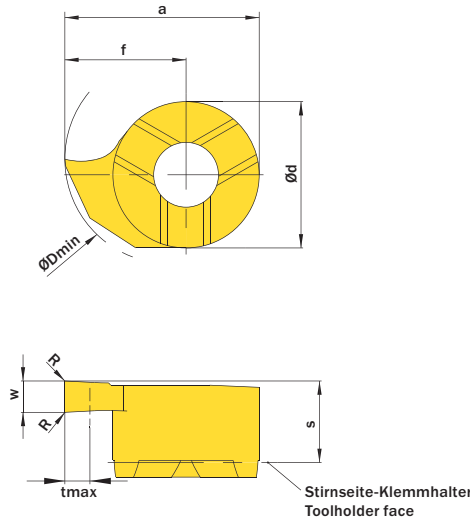
HM

R

Legende
Legend **213**

Scan
QR-Code

Oder besuchen Sie // Or Visit
www.simtek.info/cp/839



w ^{+0,03}	Nutnenbreite Nominal width of groove	ØDmin (Min. Bohrung) ØDmin (min. bore)	Artikelnummer Part number	Webcode www.simtek.com/webcode	Unsere erste Wahl Our first choice	a	Ød	f	R	S	tmax	Connectcode www.simtek.com/code
mm	mm	mm			P K M N S	mm	mm	mm	mm	mm	mm	

Fortgesetzte Tabelle Continued Table **Verwandte Werkzeuge finden Sie auch auf der vorhergehenden Seite!**
Related items can be found on the previous page as well!

0,73	0,7	10,0	D10.0070.00.10 GR/L	R AFSU L AAB2 X800 X400	9,3	7,0	5,8	-	3,9	1,2	D10
0,83	0,8	10,0	D10.0080.00.10 GR/L	R AHQS L AGM7 X800 X400	9,3	7,0	5,8	-	3,9	1,3	D10
0,93	0,9	10,0	D10.0090.00.10 GR/L	R AMHS L AG18 X800 X400	9,3	7,0	5,8	-	3,9	1,5	D10
1,0	-	10,0	D10.0100.00.10 GR/L	R AH7V L APDY X800 X400	9,3	7,0	5,8	-	3,9	1,8	D10
1,2	1,1	10,0	D10.0110.00.10 GR/L	R AC8U L ADN2 X800 X400	9,3	7,0	5,8	-	3,9	1,8	D10
1,4	1,3	10,0	D10.0130.00.10 GR/L	R ANFZ L AG0G X800 X400	9,3	7,0	5,8	-	3,9	1,8	D10
1,5	-	10,0	D10.0150.00.10 GR/L	R AG47 L AG0K X800 X400	9,3	7,0	5,8	-	3,9	1,8	D10
1,7	1,6	10,0	D10.0160.00.10 GR/L	R ANVJ L AJV0 X800 X400	9,3	7,0	5,8	-	3,9	1,8	D10
2,0	-	10,0	D10.0200.00.10 GR/L	R AAGC L APGT X800 X400	9,3	7,0	5,8	-	3,9	1,8	D10
2,388	-	10,0	D10.0238.00.10 GR/L	R A07V L A07U X800 X400	9,3	7,0	5,8	-	3,9	1,8	D10
2,5	-	10,0	D10.0250.00.10 GR/L	R AKZ9 L AH47 X800 X400	9,3	7,0	5,8	-	3,9	1,8	D10
3,0	-	10,0	D10.0300.00.10 GR/L	R AJ38 L AKF5 X800 X400	9,3	7,0	5,8	-	3,9	1,8	D10
3,175	-	10,0	D10.0318.00.10 GR/L	R AF7U L ABBT X800 X400	9,3	7,0	5,8	-	3,9	1,8	D10

Verwandte Werkzeuge finden Sie auch auf der folgenden Seite!
Related items can be found on the following page as well!

Fortgesetzte Tabelle Continued Table

Bestellbeispiel // Order example: **D10.0250.00.10 GR X800** (R = Rechte Ausführung // Right hand version, X800 = Schneidstoff // Grade)



D10. w, 1/100 mm, 4 Stellen/Digits . R, 1/100 mm, 3 Stellen/Digits .10 Toleranz // Tolerance R/L
Beispielartikelnummer // Example Part number: **D10.0156.015.10 XN R** oder/ or **D10.0156.015.10 XN L**

Nutenstechen

Für allgemeines Nutenstechen und für Sicherungsringnuten.
Geeignet ab Bohrungsdurchmesser 11,0 mm.

Grooving

For general grooving as well as for circlip ring grooving.
For use in bores as of minimum bore diameter 11,0 mm.

Schnittwerte (Start) // Cutting parameters (start)

f	Vc
0,02 mm/U	Seite/Page 429

Passende Klemmhalter auf Seite // Suitable toolholders on page
156, 161, 164

Vergleichbare Werkzeuge auf Seite // Similar tools on page
175

SP
CBN

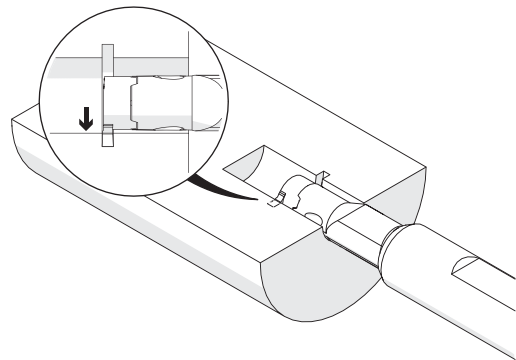
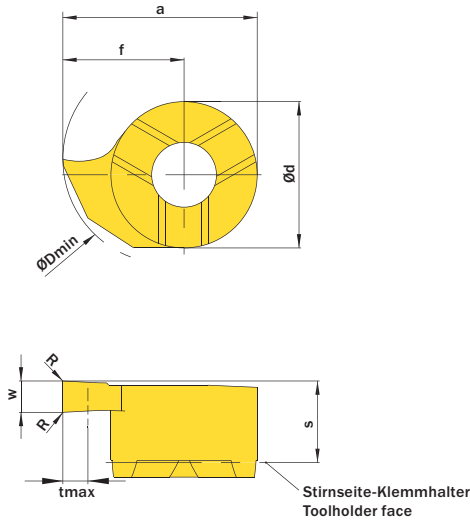
SP
HM

R

Legende
Legend **213**

Scan
QR-Code

Oder besuchen Sie // Or Visit
www.simtek.info/cp/853



w ^{+0,03}	Nutnenbreite Nominal width of groove	ØDmin (Min. Bohrung) ØDmin (min. bore)	Artikelnummer Part number	Webcode www.simtek.com/webcode	Unsere erste Wahl Our first choice	a	Ød	f	R	S	tmax	Connectcode www.simtek.com/code
mm	mm	mm			P K M N S	mm	mm	mm	mm	mm	mm	

◀ Fortgesetzte Tabelle
Continued Table

Verwandte Werkzeuge finden Sie auch auf der vorhergehenden Seite!
Related Items can be found on the previous page as well!

1,0	-	11,0	D10.0100.00.11 GR/L	R AM4Q L AFYT X800 X400	10,3	7,0	6,8	-	3,9	2,8	D10
1,5	-	11,0	D10.0150.00.11 GR/L	R AD1W L AJNG X800 X400	10,3	7,0	6,8	-	3,9	2,8	D10
2,0	-	11,0	D10.0200.00.11 GR/L	R ANQ9 L AAD7 X800 X400	10,3	7,0	6,8	-	3,9	2,8	D10
2,388	-	11,0	D10.0238.00.11 GR/L	R A07W L A07X X800 X400	10,3	7,0	6,8	-	3,9	2,8	D10
2,5	-	11,0	D10.0250.00.11 GR/L	R AFX1 L AM7Q X800 X400	10,3	7,0	6,8	-	3,9	2,8	D10
3,0	-	11,0	D10.0300.00.11 GR/L	R AANE L AHDC X800 X400	10,3	7,0	6,8	-	3,9	2,8	D10
3,175	-	11,0	D10.0318.00.11 GR/L	R AGWZ L AM7D X800 X400	10,3	7,0	6,8	-	3,9	2,8	D10

Verwandte Werkzeuge finden Sie auch auf der folgenden Seite!
Related Items can be found on the following page as well!

▶ Fortgesetzte Tabelle
Continued Table

Bestellbeispiel // Order example: **D10.0100.00.11 GR X800** (R = Rechte Ausführung // Right hand version, X800 = Schneidstoff // Grade)



D10. w. 1/100 mm, 4 Stellen/Digits . R. 1/100 mm, 3 Stellen/Digits .11 Toleranz // Tolerance R/L

Beispielartikelnummer // Example Part number: **D10.0156.015.11 XN R** oder/ or **D10.0156.015.11 XN L**

Nutenstechen

Für allgemeines Nutenstechen und für Sicherungsringnuten.
Geeignet ab Bohrungsdurchmesser 11,0 mm.

Grooving

For general grooving as well as for circlip ring grooving.
For use in bores as of minimum bore diameter 11,0 mm.

Schnittwerte (Start) // Cutting parameters (start)	
f 0,02 mm/U	Vc Seite/Page 429

Passende Klemmhalter auf Seite // Suitable toolholders on page 157, 163

Vergleichbare Werkzeuge auf Seite // Similar tools on page 175
--

SP

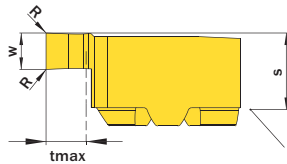
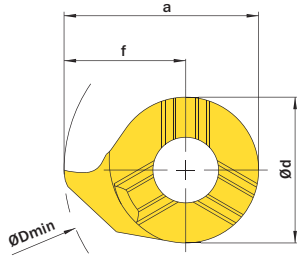
HM

R

Legende
Legend **213**

Scan
QR-Code

Oder besuchen Sie // Or Visit
www.simtek.info/cp/840



Stirnseite Klemmhalter
Toolholder face

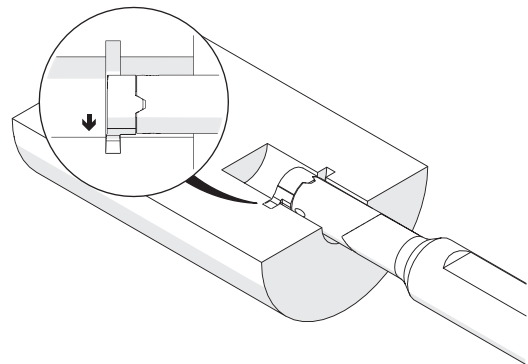


Abbildung zeigt / Drawing shows: D11.0200.00 G R

w ^{+0,03}	Nutnenbreite Nominal width of groove	ØDmin (Min. Bohrung) ØDmin (min. bore)	Artikelnummer Part number	Webcode www.simtek.com/webcode	Unsere erste Wahl Our first choice	a	Ød	f	R	S	tmax	Connectcode www.simtek.com/code
mm	mm	mm			P K M N S	mm	mm	mm	mm	mm	mm	

◀ Fortgesetzte Tabelle
Continued Table

Verwandte Werkzeuge finden Sie auch auf der vorhergehenden Seite!
Related items can be found on the previous page as well!

0,73	0,7	11,0	D11.0070.00 ZR/L	R AP1P L APPC X800 X400	10,7	8,0	6,7	-	4,2	1,2	D11	
0,787	-	11,0	D11.0078.00 ZR/L	R AMV4 L AJGV X800 X400	10,7	8,0	6,7	-	4,2	1,3	D11	inch
0,83	0,8	11,0	D11.0080.00 ZR/L	R AJWD L AAC9 X800 X400	10,7	8,0	6,7	-	4,2	1,3	D11	
0,93	0,9	11,0	D11.0090.00 ZR/L	R AJX5 L AFEU X800 X400	10,7	8,0	6,7	-	4,2	1,5	D11	
1,0	-	11,0	D11.0100.00 GR/L	R AF27 L AA5C X800 X400	10,7	8,0	6,7	-	4,2	2,3	D11	
1,2	1,1	11,0	D11.0110.00 GR/L	R AC49 L APP0 X800 X400	10,7	8,0	6,7	-	4,2	2,3	D11	
1,4	1,3	11,0	D11.0130.00 GR/L	R ABF3 L ABS9 X800 X400	10,7	8,0	6,7	-	4,2	2,3	D11	
1,5	-	11,0	D11.0150.00 GR/L	R ADEV L AMGD X800 X400	10,7	8,0	6,7	-	4,2	2,3	D11	
1,575	-	11,0	D11.0157.00 GR/L	R AEAT L APWW X800 X400	10,7	8,0	6,7	-	4,2	2,3	D11	inch
1,7	1,6	11,0	D11.0160.00 GR/L	R AK4Q L AJUG X800 X400	10,7	8,0	6,7	-	4,2	2,3	D11	
2,0	-	11,0	D11.0200.00 GR/L	R AKEC L AP30 X800 X400	10,7	8,0	6,7	-	4,2	2,3	D11	
2,388	-	11,0	D11.0238.00 GR/L	R ANH9 L AHA0 X800 X400	10,7	8,0	6,7	-	4,2	2,3	D11	inch
2,5	-	11,0	D11.0250.00 GR/L	R AB6U L AM90 X800 X400	10,7	8,0	6,7	-	4,2	2,3	D11	
3,0	-	11,0	D11.0300.00 GR/L	R AP3N L AA AF X800 X400	10,7	8,0	6,7	-	4,2	2,3	D11	
3,175	-	11,0	D11.0318.00 GR/L	R AKB5 L AF8V X800 X400	10,7	8,0	6,7	-	4,2	2,3	D11	inch

Verwandte Werkzeuge finden Sie auch auf der folgenden Seite!
Related items can be found on the following page as well!

▶ Fortgesetzte Tabelle
Continued Table

Bestellbeispiel // Order example: **D11.0110.00 GR X800** (R = Rechte Ausführung // Right hand version, X800 = Schneidstoff // Grade)



D11. w. 1/100 mm, 4 Stellen/Digits | R. 1/100 mm, 3 Stellen/Digits | Toleranz // Tolerance R/L

Beispielartikelnummer // Example Part number: **D11.0156.015 XNR** oder/for **D11.0156.015 XNL**

Nutenstechen

Für allgemeines Nutenstechen und für Sicherungsringnuten.
 Geeignet ab Bohrungsdurchmesser 12,0 mm.

Grooving

For general grooving as well as for circlip ring grooving.
 For use in bores as of minimum bore diameter 12,0 mm.

Schnittwerte (Start) // Cutting parameters (start)

f	Vc
0,02 mm/U	Seite/Page 429

Passende Klemmhalter auf Seite // Suitable toolholders on page
156, 161, 164

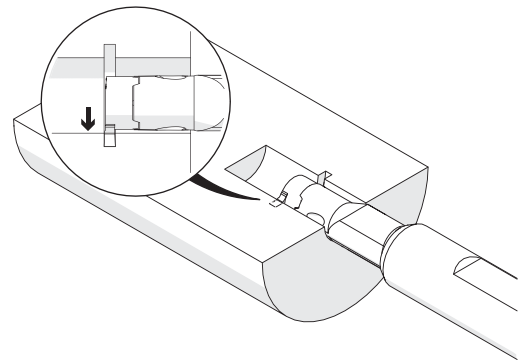
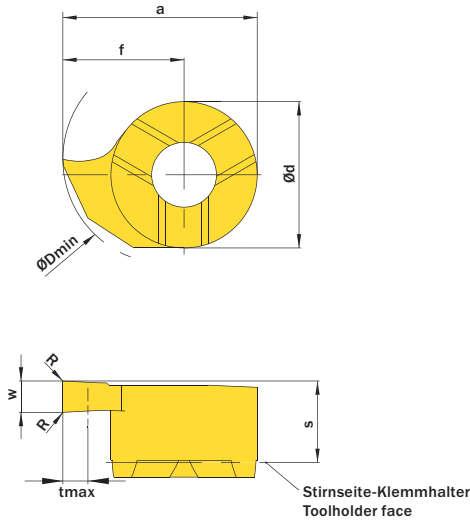
Vergleichbare Werkzeuge auf Seite // Similar tools on page
175



SP
HM
R

Legende
 Legend **213**

Scan QR-Code Oder besuchen Sie // Or Visit
www.simtek.info/cp/854



w ^{+0,03}	Nutnenbreite Nominal width of groove	ØDmin (Min. Bohrung) ØDmin (min. bore)	Artikelnummer Part number	Webcode www.simtek.com/webcode	Unsere erste Wahl Our first choice	a	Ød	f	R	S	tmax	Connectcode www.simtek.com/code
mm	mm	mm			P K M N S	mm	mm	mm	mm	mm	mm	

◀ Fortgesetzte Tabelle
 Continued Table

Verwandte Werkzeuge finden Sie auch auf der vorhergehenden Seite!
 Related items can be found on the previous page as well!

1,0	-	12,0	D10.0100.00.12 GR/L	R AJBX L AMJU	X800 X400	10,9	7,0	7,4	-	3,8	3,4	D10
1,5	-	12,0	D10.0150.00.12 GR/L	R ABE6 L AGJW	X800 X400	10,9	7,0	7,4	-	3,9	3,4	D10
2,0	-	12,0	D10.0200.00.12 GR/L	R AHWQ L AETB	X800 X400	10,9	7,0	7,4	-	3,9	3,4	D10

Verwandte Werkzeuge finden Sie auch auf der folgenden Seite!
 Related items can be found on the following page as well!

Fortgesetzte Tabelle
 Continued Table ▶

Bestellbeispiel // Order example: **D10.0100.00.12 GR X800** (R = Rechte Ausführung // Right hand version, X800 = Schneidstoff // Grade)



D10. **w, 1/100 mm, 4 Stellen/Digits** . **R, 1/100 mm, 3 Stellen/Digits** .12 Toleranz // Tolerance R/L
 Beispielpartikelnummer // Example Part number: **D10.0156.015.12 XNR** oder/ or **D10.0156.015.12 XNL**

Nutenstechen

Für allgemeines Nutenstechen und für Sicherungsringnuten.
Geeignet ab Bohrungsdurchmesser 14,0 mm.

Grooving

For general grooving as well as for circlip ring grooving.
For use in bores as of minimum bore diameter 14,0 mm.

Schnittwerte (Start) // Cutting parameters (start)

f	Vc
0,02 mm/U	Seite/Page 429

Passende Klemmhalter auf Seite // Suitable toolholders on page
158, 161, 164

Vergleichbare Werkzeuge auf Seite // Similar tools on page
175

SP

HM

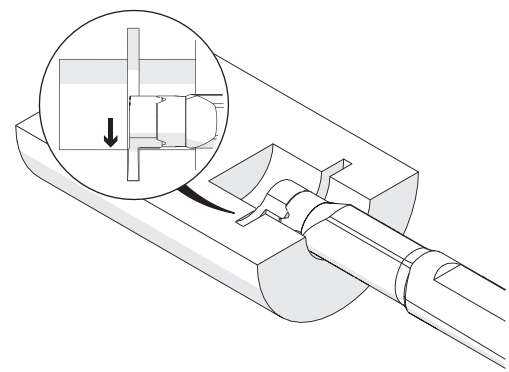
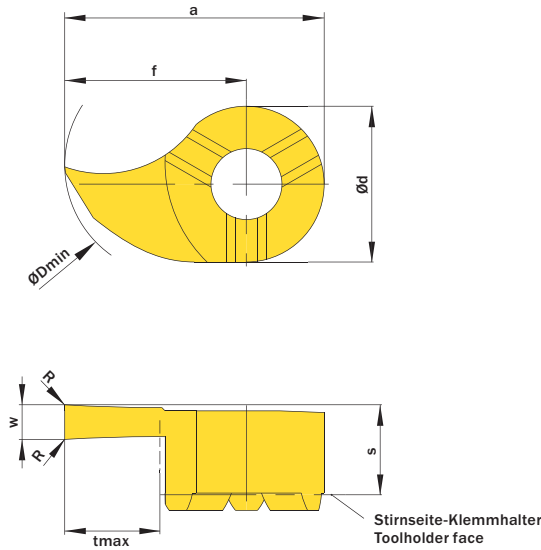
R

Legende
Legend

213

Scan
QR-Code

Oder besuchen Sie // Or Visit
www.simtek.info/cp/841



w ^{+0,03}	Nutnenbreite Nominal width of groove	ØDmin (Min. Bohrung) ØDmin (min. bore)	Artikelnummer Part number	Webcode <small>www.simtek.com/webcode</small>	Unsere erste Wahl Our first choice	a	Ød	f	R	S	tmax	Connectcode <small>www.simtek.com/code</small>
mm	mm	mm			P K M N S	mm	mm	mm	mm	mm	mm	

◀ Fortgesetzte Tabelle Continued Table Verwandte Werkzeuge finden Sie auch auf der vorhergehenden Seite! Related Items can be found on the previous page as well!

0,73	0,7	14,0	D14.0070.00 ZR/L	R AB83 L AMAH	X800 X400	13,5	9,0	9,0	-	5,2	1,2	D14
0,787	-	14,0	D14.0078.00 ZR/L	R AFD3 L AJØC	X800 X400	13,5	9,0	9,0	-	5,2	1,3	D14
0,83	0,8	14,0	D14.0080.00 ZR/L	R AF8T L AMXS	X800 X400	13,5	9,0	9,0	-	5,2	1,3	D14
0,86	-	14,0	D14.0086.00 ZR/L	R AJV2 L ADKX	X800 X400	13,5	9,0	9,0	-	5,2	1,5	D14
0,93	0,9	14,0	D14.0090.00 ZR/L	R AEAM L ADZA	X800 X400	13,5	9,0	9,0	-	5,2	1,5	D14
1,0	-	14,0	D14.0100.00 ZR/L	R APFC L AMY9	X800 X400	13,5	9,0	9,0	-	5,2	4,0	D14
1,2	1,1	14,0	D14.0110.00 GR/L	R AK84 L AM81	X800 X400	13,5	9,0	9,0	-	5,3	4,0	D14
1,4	1,3	14,0	D14.0130.00 GR/L	R ADGC L AAFB	X800 X400	13,5	9,0	9,0	-	5,3	4,0	D14
1,5	-	14,0	D14.0150.00 GR/L	R AK6Q L AAJG	X800 X400	13,5	9,0	9,0	-	5,3	4,0	D14
1,575	-	14,0	D14.0157.00 GR/L	R ANYM L AFDN	X800 X400	13,5	9,0	9,0	-	5,3	4,0	D14
1,7	1,6	14,0	D14.0160.00 GR/L	R AJTA L AC77	X800 X400	13,5	9,0	9,0	-	5,3	4,0	D14
2,0	-	14,0	D14.0200.00 GR/L	R AG8N L AMW3	X800 X400	13,5	9,0	9,0	-	5,3	4,0	D14
2,388	-	14,0	D14.0238.00 GR/L	R ACPC L AB79	X800 X400	13,5	9,0	9,0	-	5,3	4,0	D14
2,5	-	14,0	D14.0250.00 GR/L	R AHSS L AA56	X800 X400	13,5	9,0	9,0	-	5,3	4,0	D14
3,0	-	14,0	D14.0300.00 GR/L	R AFFU L AHHA	X800 X400	13,5	9,0	9,0	-	5,3	4,0	D14
3,175	-	14,0	D14.0318.00 GR/L	R AKKN L APJD	X800 X400	13,5	9,0	9,0	-	5,3	4,0	D14

▶ Verwandte Werkzeuge finden Sie auch auf der folgenden Seite! Related Items can be found on the following page as well! Fortgesetzte Tabelle Continued Table

|| Bestellbeispiel // Order example: **D14.0200.00 GR X800** (R = Rechte Ausführung // Right hand version, X800 = Schneidstoff // Grade)

simtek individual D14. w. 1/100 mm, 4 Stellen/Digits R. 1/100 mm, 3 Stellen/Digits Toleranz // Tolerance R/L
Beispielartikelnummer // Example Part number: **D14.0156.015 XNR** oder/for **D14.0156.015 XNL**

Nutenstechen

Für allgemeines Nutenstechen und für Sicherungsringnuten.
Geeignet ab Bohrungsdurchmesser 16,0 mm.

Grooving

For general grooving as well as for circlip ring grooving.
For use in bores as of minimum bore diameter 16,0 mm.

Schnittwerte (Start) // Cutting parameters (start)

f	Vc
0,02 mm/U	Seite/Page 429

Passende Klemmhalter auf Seite // Suitable toolholders on page
158, 161, 164

Vergleichbare Werkzeuge auf Seite // Similar tools on page
175

SP

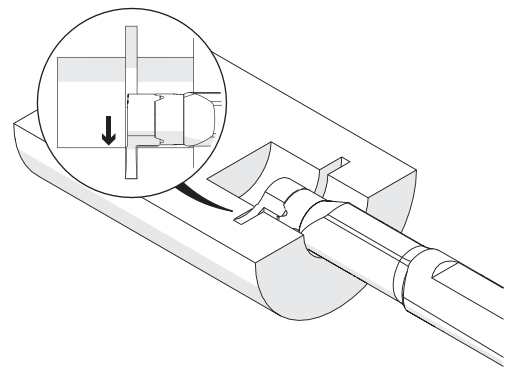
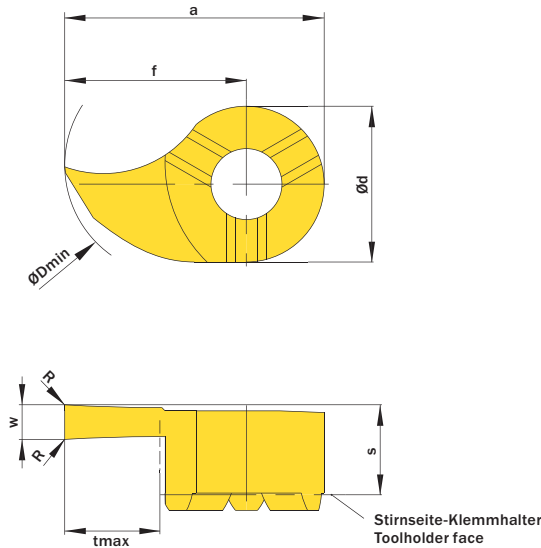
HM

R

Legende
Legend **213**

Scan
QR-Code

Oder besuchen Sie // Or Visit
www.simtek.info/cp/855



w ^{+0,03}	Nutnenbreite Nominal width of groove	ØDmin (Min. Bohrung) ØDmin (min. bore)	Artikelnummer Part number	Webcode www.simtek.com/webcode	Unsere erste Wahl Our first choice	a	Ød	f	R	S	tmax	Connectcode www.simtek.com/code
mm	mm	mm			P K M N S	mm	mm	mm	mm	mm	mm	

◀ Fortgesetzte Tabelle Continued Table Verwandte Werkzeuge finden Sie auch auf der vorhergehenden Seite!
Related items can be found on the previous page as well!

1,5	-	16,0	D14.0150.00.16 GR/L	R ANA2 L AG4U	X800 X400	15,0	9,0	10,5	-	5,0	5,5	D14
2,0	-	16,0	D14.0200.00.16 GR/L	R AAV5 L AKC6	X800 X400	15,0	9,0	10,5	-	5,2	5,5	D14
2,5	-	16,0	D14.0250.00.16 GR/L	R AN8C L AKHJ	X800 X400	15,0	9,0	10,5	-	5,2	5,5	D14
3,0	-	16,0	D14.0300.00.16 GR/L	R ANWY L ABDA	X800 X400	15,0	9,0	10,5	-	5,2	5,5	D14

Verwandte Werkzeuge finden Sie auch auf der folgenden Seite!
Related items can be found on the following page as well!

Fortgesetzte Tabelle
Continued Table ▶

Bestellbeispiel // Order example: **D14.0200.00.16 GR X800** (R = Rechte Ausführung // Right hand version, X800 = Schneidstoff // Grade)

simtek individual D14. w. 1/100 mm, 4 Stellen/Digits . R. 1/100 mm, 3 Stellen/Digits .16 Toleranz // Tolerance R/L
Beispielartikelnummer // Example Part number: **D14.0156.015.16 XNR** oder/or **D14.0156.015.16 XNL**

Nutenstechen

Für allgemeines Nutenstechen und für Sicherungsringnuten.
Geeignet ab Bohrungsdurchmesser 16,0 mm.

Grooving

For general grooving as well as for circlip ring grooving.
For use in bores as of minimum bore diameter 16,0 mm.

Schnittwerte (Start) // Cutting parameters (start)	
f 0,02 mm/U	Vc Seite/Page 429

Passende Klemmhalter auf Seite // Suitable toolholders on page
159, 163

Vergleichbare Werkzeuge auf Seite // Similar tools on page
175

SP **SP**
CBN **HM** **R**

Legende
Legend **213**

Scan
QR-Code Oder besuchen Sie // Or Visit
www.simtek.info/cp/842

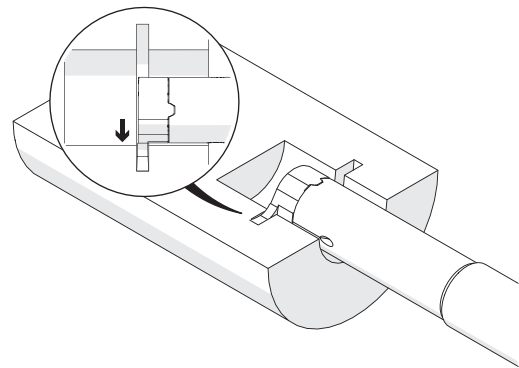
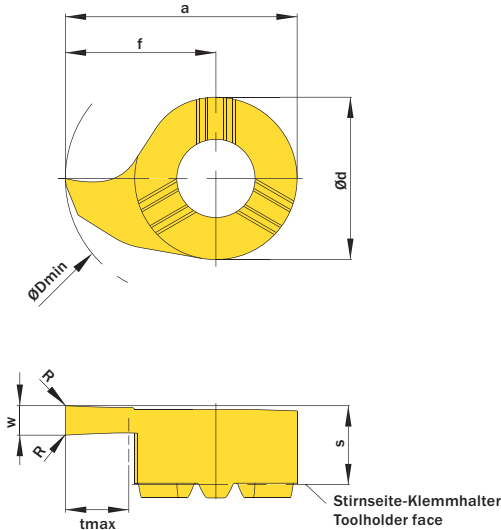


Abbildung zeigt / Drawing shows: D16.0200.00 G R

w ^{+0,03}	Nutnenbreite Nominal width of groove	ØDmin (Min. Bohrung) ØDmin (min. bore)	Artikelnummer Part number	Webcode www.simtek.com/webcode	Unsere erste Wahl Our first choice	a	Ød	f	R	S	tmax	Connectcode www.simtek.com/code
mm	mm	mm			P K M N S	mm	mm	mm	mm	mm	mm	

Fortgesetzte Tabelle // Continued Table
Verwandte Werkzeuge finden Sie auch auf der vorhergehenden Seite!
Related items can be found on the previous page as well!

0,73	0,7	16,0	D16.0070.00 ZR/L	R AF7C L AN2X X800 X400	15,7	11,0	10,2	-	5,2	1,2	D16
0,787	-	16,0	D16.0078.00 ZR/L	R AMHC L AHKC X800 X400	15,7	11,0	10,2	-	5,2	1,3	D16
0,83	0,8	16,0	D16.0080.00 ZR/L	R AATC L AFUU X800 X400	15,7	11,0	10,2	-	5,2	1,3	D16
0,93	0,9	16,0	D16.0090.00 ZR/L	R ADHV L ABYM X800 X400	15,7	11,0	10,2	-	5,2	1,5	D16
1,0	1,0	16,0	D16.0100.00 ZR/L	R AHE1 L AMU9 X800 X400	15,7	11,0	10,2	-	5,2	1,3	D16
1,2	1,1	16,0	D16.0110.00 GR/L	R AKCH L AGF2 X800 X400	15,7	11,0	10,2	-	5,4	4,3	D16
1,4	1,3	16,0	D16.0130.00 GR/L	R AEQ6 L ADJ0 X800 X400	15,7	11,0	10,2	-	5,4	4,3	D16
1,5	-	16,0	D16.0150.00 GR/L	R AEX2 L ACK6 X800 X400	15,7	11,0	10,2	-	5,4	4,3	D16
1,575	-	16,0	D16.0157.00 GR/L	R APGQ L AHAE X800 X400	15,7	11,0	10,2	-	5,4	4,3	D16
1,7	1,6	16,0	D16.0160.00 GR/L	R ANNC L AGBT X800 X400	15,7	11,0	10,2	-	5,4	4,3	D16
2,0	-	16,0	D16.0200.00 GR/L	R ACXX L APFT X800 X400	15,7	11,0	10,2	-	5,4	4,3	D16
2,5	-	16,0	D16.0250.00 GR/L	R AAMN L AA16 X800 X400	15,7	11,0	10,2	-	5,4	4,3	D16
3,0	-	16,0	D16.0300.00 GR/L	R AHSW L AHXD X800 X400	15,7	11,0	10,2	-	5,4	4,3	D16
3,5	-	16,0	D16.0350.00 GR/L	R ADH9 L AFEH X800 X400	15,7	11,0	10,2	-	5,4	4,3	D16
4,0	-	16,0	D16.0400.00 GR/L	R ACJ0 L AE9X X800 X400	15,7	11,0	10,2	-	5,4	4,3	D16

Verwandte Werkzeuge finden Sie auch auf der folgenden Seite!
Related items can be found on the following page as well!

Fortgesetzte Tabelle
Continued Table

Bestellbeispiel // Order example: **D16.0150.00 GR X800** (R = Rechte Ausführung // Right hand version, X800 = Schneidstoff // Grade)



D16. w. 1/100 mm, 4 Stellen/Digits | R. 1/100 mm, 3 Stellen/Digits | Toleranz // Tolerance R/L
Beispielartikelnummer // Example Part number: **D16.0156.015 XNR** oder/for **D16.0156.015 XNL**

Nutenstechen

Für allgemeines Nutenstechen und für Sicherungsringnuten.
Geeignet ab Bohrungsdurchmesser 17,0 mm.

Grooving

For general grooving as well as for circlip ring grooving.
For use in bores as of minimum bore diameter 17,0 mm.

Schnittwerte (Start) // Cutting parameters (start)	
f 0,02 mm/U	Vc Seite/Page 429

Passende Klemmhalter auf Seite // Suitable toolholders on page
158, 161, 164

Vergleichbare Werkzeuge auf Seite // Similar tools on page
175

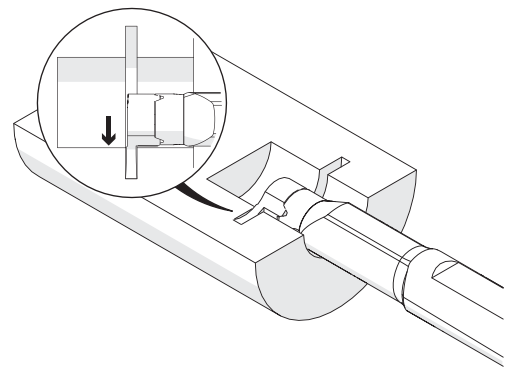
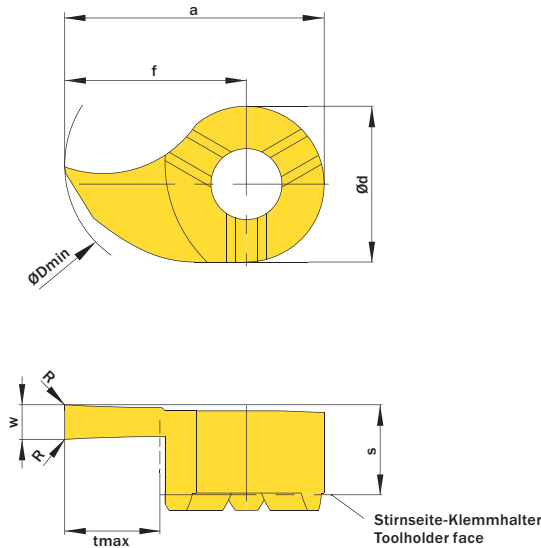
SP

HM

R

Legende
Legend **213**

Oder besuchen Sie // Or Visit
www.simtek.info/cp/856



w ^{+0,03}	Nuttenbreite Nominal width of groove	ØDmin (Min. Bohrung) ØDmin (min. bore)	Artikelnummer Part number	Webcode www.simtek.com/webcode	Unsere erste Wahl Our first choice	a	Ød	f	R	S	tmax	Connectcode www.simtek.com/code
mm	mm	mm			P K M N S	mm	mm	mm	mm	mm	mm	

◀ Fortgesetzte Tabelle Continued Table Verwandte Werkzeuge finden Sie auch auf der vorhergehenden Seite!
Related Items can be found on the previous page as well!

1,5	-	17,0	D14.0150.00.17 GR/L	R AJDY L APPU	X800 X400	16,0	9,0	11,5	-	5,0	6,5	D14
2,0	-	17,0	D14.0200.00.17 GR/L	R AB9C L AH3A	X800 X400	16,0	9,0	11,5	-	5,2	6,5	D14
2,5	-	17,0	D14.0250.00.17 GR/L	R ANU2 L AFBS	X800 X400	16,0	9,0	11,5	-	5,2	6,5	D14
3,0	-	17,0	D14.0300.00.17 GR/L	R AATP L AHW1	X800 X400	16,0	9,0	11,5	-	5,2	6,5	D14

Verwandte Werkzeuge finden Sie auch auf der folgenden Seite!
Related Items can be found on the following page as well!

Fortgesetzte Tabelle Continued Table ▶

■ Bestellbeispiel // Order example: **D14.0200.00.17 GR X800** (R = Rechte Ausführung // Right hand version, X800 = Schneidstoff // Grade)

simtek individual D14. w. 1/100 mm, 4 Stellen/Digits R. 1/100 mm, 3 Stellen/Digits .17 Toleranz // Tolerance R/L
Beispielartikelnummer // Example Part number: **D14.0156.015.17 XNR** oder/ or **D14.0156.015.17 XNL**

Nutenstechen

Für allgemeines Nutenstechen und für Sicherungsringnuten.
Geeignet ab Bohrungsdurchmesser 18,0 mm.

Grooving

For general grooving as well as for circlip ring grooving.
For use in bores as of minimum bore diameter 18,0 mm.

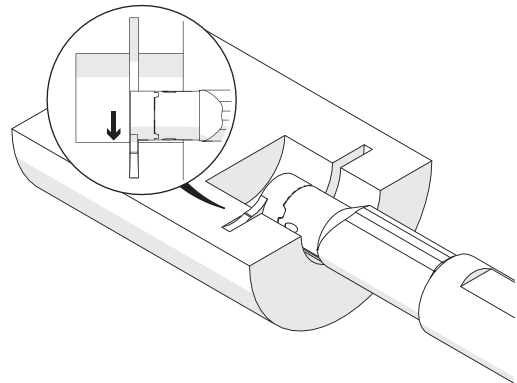
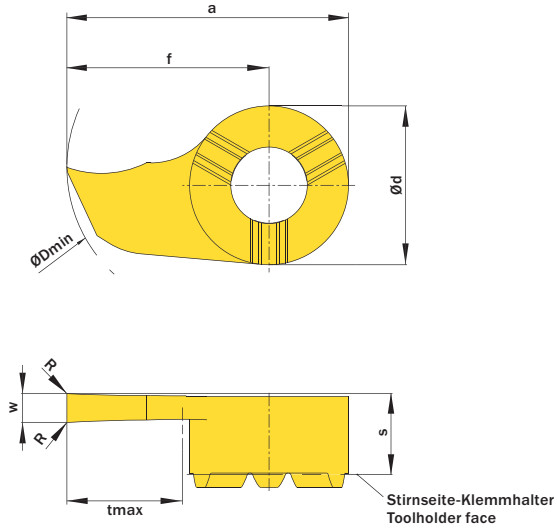
Schnittwerte (Start) // Cutting parameters (start)	
f 0,02 mm/U	Vc Seite/Page 429

Passende Klemmhalter auf Seite // Suitable toolholders on page
160, 164

Vergleichbare Werkzeuge auf Seite // Similar tools on page
175

SP **HM** **R** Legende Legend **213**

Scan QR-Code Oder besuchen Sie // Or Visit www.simtek.info/cp/843



w ^{+0,03}	Nutnenbreite Nominal width of groove	ØDmin (Min. Bohrung) ØDmin (min. bore)	Artikelnummer Part number	Webcode www.simtek.com/webcode	Unsere erste Wahl Our first choice	a	Ød	f	R	S	tmax	Connectcode www.simtek.com/code
mm	mm	mm			P K M N S	mm	mm	mm	mm	mm	mm	

Fortgesetzte Tabelle Continued Table		Verwandte Werkzeuge finden Sie auch auf der vorhergehenden Seite! Related items can be found on the previous page as well!										
1,5	-	18,0	D18.0150.00.18 GR/L	R AKZ7 L AM2H	X800 X400	17,5	11,0	12,0	-	5,6	6,0	D18
2,0	-	18,0	D18.0200.00.18 GR/L	R AJ4W L AJFJ	X800 X400	17,5	11,0	12,0	-	5,6	6,0	D18
2,388	-	18,0	D18.0238.00.18 GR/L	R A1DG L A1DJ	X800 X400	17,5	11,0	12,0	-	5,6	6,0	D18 inch
2,5	-	18,0	D18.0250.00.18 GR/L	R ADDT L AEK0	X800 X400	17,5	11,0	12,0	-	5,6	6,0	D18
3,0	-	18,0	D18.0300.00.18 GR/L	R AM20 L ANNX	X800 X400	17,5	11,0	12,0	-	5,6	6,0	D18
3,175	-	18,0	D18.0318.00.18 GR/L	R AVWC L AVWD	X800 X400	17,5	11,0	12,0	-	5,6	6,0	D18 inch
3,5	-	18,0	D18.0350.00.18 GR/L	R AGY9 L ACQ7	X800 X400	17,5	11,0	12,0	-	5,6	6,0	D18
4,0	-	18,0	D18.0400.00.18 GR/L	R AC7M L AAVV	X800 X400	17,5	11,0	12,0	-	5,6	6,0	D18

Verwandte Werkzeuge finden Sie auch auf der folgenden Seite!
Related items can be found on the following page as well!

Fortgesetzte Tabelle
Continued Table

Bestellbeispiel // Order example: **D18.0300.00.18 GR X800** (R = Rechte Ausführung // Right hand version, X800 = Schneidstoff // Grade)



D18. w, 1/100 mm, 4 Stellen/Digits . R, 1/100 mm, 3 Stellen/Digits .18 Toleranz // Tolerance R/L
Beispielartikelnummer // Example Part number: **D18.0156.015.18 XN R** oder/ or **D18.0156.015.18 XN L**

Nutenstechen

Für allgemeines Nutenstechen und für Sicherungsringnuten.
Geeignet ab Bohrungsdurchmesser 20,0 mm.

Grooving

For general grooving as well as for circlip ring grooving.
For use in bores as of minimum bore diameter 20,0 mm.

Schnittwerte (Start) // Cutting parameters (start)

f	Vc
0,02 mm/U	Seite/Page 429

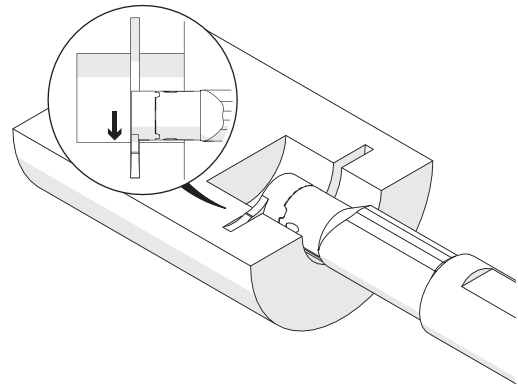
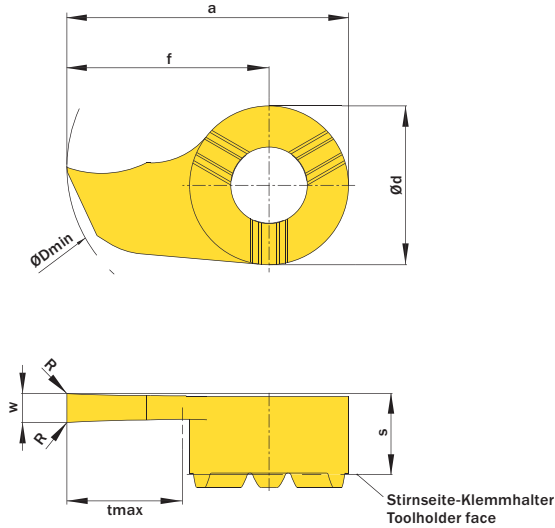
Passende Klemmhalter auf Seite // Suitable toolholders on page
160, 164

Vergleichbare Werkzeuge auf Seite // Similar tools on page
175



Legende
Legend **213**

Scan QR-Code Oder besuchen Sie // Or Visit
www.simtek.info/cp/857



w ^{+0,03}	Nutnenbreite Nominal width of groove	ØDmin (Min. Bohrung) ØDmin (min. bore)	Artikelnummer Part number	Webcode www.simtek.com/webcode	Unsere erste Wahl Our first choice	a	Ød	f	R	S	tmax	Connectcode www.simtek.com/ccode
mm	mm	mm			P K M N S	mm	mm	mm	mm	mm	mm	

Fortgesetzte Tabelle
Continued Table

Verwandte Werkzeuge finden Sie auch auf der vorhergehenden Seite!
Related items can be found on the previous page as well!

1,5	-	20,0	D18.0150.00.20 GR/L	R AMAQ L AB14	X800 X400	19,5	11,0	14,0	-	5,6	8,0	D18
2,0	-	20,0	D18.0200.00.20 GR/L	R AM2K L AMM9	X800 X400	19,5	11,0	14,0	-	5,6	8,0	D18
2,388	-	20,0	D18.0238.00.20 GR/L	R A1D3 L A1D2	X800 X400	19,5	11,0	14,0	-	5,6	8,0	D18
2,5	-	20,0	D18.0250.00.20 GR/L	R ADCV L AABA	X800 X400	19,5	11,0	14,0	-	5,6	8,0	D18
3,0	-	20,0	D18.0300.00.20 GR/L	R AF2Q L AEJG	X800 X400	19,5	11,0	14,0	-	5,6	8,0	D18
3,5	-	20,0	D18.0350.00.20 GR/L	R AJSF L AEH4	X800 X400	19,5	11,0	14,0	-	5,6	8,0	D18
4,0	-	20,0	D18.0400.00.20 GR/L	R AMJZ L AEAS	X800 X400	19,5	11,0	14,0	-	5,6	8,0	D18

Bestellbeispiel // Order example: **D18.0300.00.20 GR X800** (R = Rechte Ausführung // Right hand version, X800 = Schneidstoff // Grade)



D18. w, 1/100 mm, 4 Stellen/Digits . R, 1/100 mm, 3 Stellen/Digits .20 Toleranz // Tolerance R/L
Beispielartikelnummer // Example Part number: **D18.0156.015.20 XN R** oder/ or **D18.0156.015.20 XN L**

Einstecken und Profildrehen

Geeignet ab Bohrungsdurchmesser 7,8 mm.

Grooving and Profiling

For use in bores as of minimum bore diameter 7,8 mm.

Schnittwerte (Start) // Cutting parameters (start)	
f	Vc
0,02 mm/U	Seite/Page 429

Passende Klemmhalter auf Seite // Suitable toolholders on page
153, 154, 155, 156, 157, 161, 162, 163, 164

SP **HM** **R**

Legende Legend **213**

Scan QR-Code Oder besuchen Sie // Or Visit www.simtek.info/cp/827

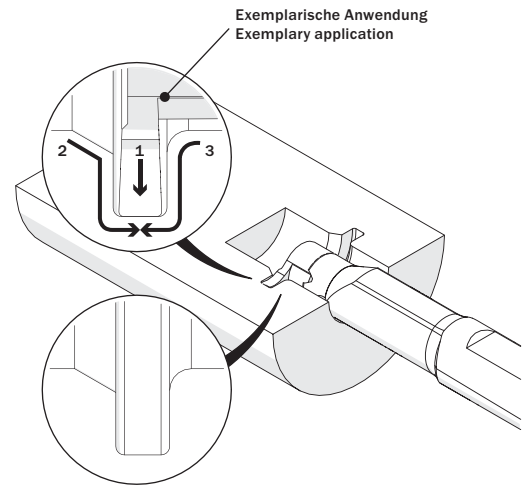
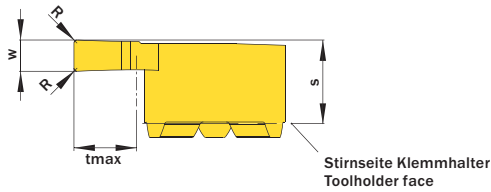
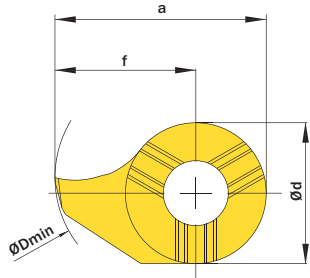


Abbildung zeigt / Drawing shows: D14.0200.02 N R

w ^{+0,03}	R	Artikelnummer Part number	Webcode www.simtek.com/webcode	Unsere erste Wahl Our first choice	a	Ød	ØDmin (Min. Bohrung) ØDmin (min. bore)	f	s	tmax	Connectcode www.simtek.com/code
mm	mm			P K M N S	mm	mm	mm	mm	mm	mm	
▼ ØDmin (Min. Bohrung) // ØDmin (min. bore) = 7,8 mm											
1,5	0,2	D07.0150.02.08 NR/L	R AWYH L AXA7	X800 X400	7,6	4,8	7,8	5,2	3,7	2,0	D07
▼ ØDmin (Min. Bohrung) // ØDmin (min. bore) = 8,0 mm											
0,787	0,2	D08.0078.02 NR/L	R APNC L AKC1	X800 X400	7,8	6,0	8,0	4,8	3,3	1,0	D08
1,168	0,2	D08.0117.02 NR/L	R AHXK L AD7H	X800 X400	7,8	6,0	8,0	4,8	3,3	1,0	D08
1,5	0,2	D08.0150.02 NR/L	R AECN L AGPE	X800 X400	7,8	6,0	8,0	4,8	3,3	1,0	D08
1,575	0,2	D08.0157.02 NR/L	R AMCC L AJX9	X800 X400	7,8	6,0	8,0	4,8	3,3	1,0	D08
1,981	0,2	D08.0198.02 NR/L	R ABWJ L AEJC	X800 X400	7,8	6,0	8,0	4,8	3,3	1,0	D08
2,0	0,2	D08.0200.02 NR/L	R AMEP L AC18	X800 X400	7,8	6,0	8,0	4,8	3,3	1,0	D08
▼ ØDmin (Min. Bohrung) // ØDmin (min. bore) = 9,0 mm											
1,5	0,2	D09.0150.02.09 NR/L	R AWF5 L AWHJ	X800 X400	8,6	6,2	9,0	5,5	3,6	1,8	D09
2,0	0,2	D09.0200.02.09 NR/L	R AWF4 L AWHH	X800 X400	8,6	6,2	9,0	5,5	3,6	1,8	D09
▼ ØDmin (Min. Bohrung) // ØDmin (min. bore) = 10,0 mm											
1,5	0,2	D09.0150.02.10 NR/L	R AWF3 L AWHG	X800 X400	9,6	6,2	10,0	6,5	3,6	2,8	D09
2,0	0,2	D09.0200.02.10 NR/L	R AWF2 L AWHF	X800 X400	9,6	6,2	10,0	6,5	3,6	2,8	D09
1,5	0,2	D10.0150.02.10 NR/L	R ADUV L AECA	X800 X400	9,3	7,0	10,0	5,8	3,9	1,8	D10
1,981	0,2	D10.0198.02.10 NR	A3QF	X800 X400	9,3	7,0	10,0	5,8	3,9	1,8	D10
2,0	0,2	D10.0200.02.10 NR/L	R AFBK L AEFM	X800 X400	9,3	7,0	10,0	5,8	3,9	1,8	D10
▼ ØDmin (Min. Bohrung) // ØDmin (min. bore) = 11,0 mm											
0,787	0,2	D11.0078.02 NR/L	R AFKN L AJU6	X800 X400	10,7	8,0	11,0	6,7	4,2	2,3	D11
1,0	0,2	D11.0100.02 NR/L	R AKQH L AM70	X800 X400	10,7	8,0	11,0	6,7	4,2	2,3	D11
1,5	0,2	D11.0150.02 NR/L	R AJCU L AHWV	X800 X400	10,7	8,0	11,0	6,7	4,2	2,3	D11
1,575	0,2	D11.0157.02 NR/L	R AEUY L AM4E	X800 X400	10,7	8,0	11,0	6,7	4,2	2,3	D11
2,0	0,2	D11.0200.02 NR/L	R AN5N L ANG5	X800 X400	10,7	8,0	11,0	6,7	4,2	2,3	D11

Verwandte Werkzeuge finden Sie auch auf der folgenden Seite!
Related Items can be found on the following page as well!

Fortgesetzte Tabelle
Continued Table

Bestellbeispiel // Order example: **D11.0200.02 NR X800** (R = Rechte Ausführung // Right hand version, X800 = Schneidstoff // Grade)

Einstecken und Profildrehen

Geeignet ab Bohrungsdurchmesser 11,0 mm.

Grooving and Profiling

For use in bores as of minimum bore diameter 11,0 mm.

Schnittwerte (Start) // Cutting parameters (start)

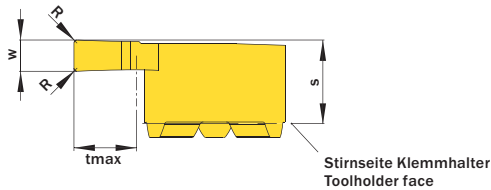
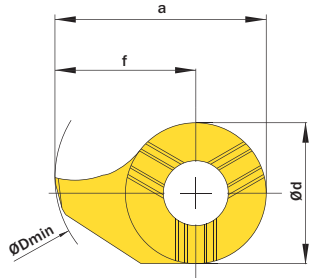
f	Vc
0,02 mm/U	Seite/Page 429

Passende Klemhalter auf Seite // Suitable toolholders on page
156, 158, 161, 164



Legende
Legend **213**

Scan QR-Code Oder besuchen Sie // Or Visit
www.simtek.info/cp/845



Stirnseite Klemhalter
Toolholder face

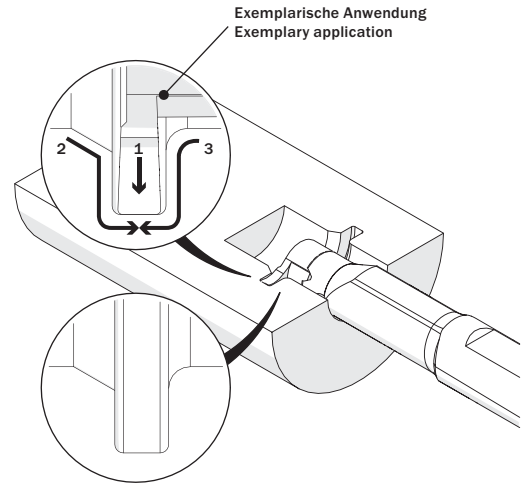


Abbildung zeigt / Drawing shows: D14.0200.02 NR

w ^{+0,03}	R	Artikelnummer Part number	Webcode www.simtek.com/webcode	Unsere erste Wahl Our first choice	a	Ød	ØDmin (Min. Bohrung) ØDmin (min. bore)	f	s	tmax	Connectcode www.simtek.com/code
mm	mm			P K M N S	mm	mm	mm	mm	mm	mm	

◀ Fortgesetzte Tabelle Continued Table Verwandte Werkzeuge finden Sie auch auf der vorhergehenden Seite! Related items can be found on the previous page as well!

▼ ØDmin (Min. Bohrung) // ØDmin (min. bore) = 11,0 mm												
1,5	0,2	D10.0150.02.11 NR/L	R AC7X	L AFDW	X800 X400	10,3	7,0	11,0	6,8	3,9	2,8	D10
2,0	0,2	D10.0200.02.11 NR/L	R AFDH	L AFVF	X800 X400	10,3	7,0	11,0	6,8	3,9	2,8	D10
▼ ØDmin (Min. Bohrung) // ØDmin (min. bore) = 12,0 mm												
1,5	0,2	D10.0150.02.12 NR/L	R AKG7	L AHN7	X800 X400	10,9	7,0	12,0	7,4	3,9	3,4	D10
2,0	0,2	D10.0200.02.12 NR/L	R ANQ8	L APHA	X800 X400	10,9	7,0	12,0	7,4	3,9	3,4	D10
▼ ØDmin (Min. Bohrung) // ØDmin (min. bore) = 14,0 mm												
0,787	0,2	D14.0078.02 NR/L	R AB9B	L AKSV	X800 X400	13,5	9,0	14,0	9,0	5,3	4,0	D14
1,168	0,2	D14.0117.02 NR/L	R AAC	L AKHN	X800 X400	13,5	9,0	14,0	9,0	5,3	4,0	D14 <small>inch new</small>
1,5	0,2	D14.0150.02 NR/L	R AAHD	L ABEJ	X800 X400	13,5	9,0	14,0	9,0	5,3	4,0	D14
1,575	0,2	D14.0157.02 NR/L	R AMQ3	L ABFX	X800 X400	13,5	9,0	14,0	9,0	5,3	4,0	D14 <small>inch</small>
1,979	0,2	D14.0198.02 NR/L	R APT4	L AA5X	X800 X400	13,5	9,0	14,0	9,0	5,3	4,0	D14 <small>inch</small>
2,0	0,2	D14.0200.02 NR/L	R AC2N	L APKA	X800 X400	13,5	9,0	14,0	9,0	5,3	4,0	D14
2,5	0,2	D14.0250.02 NR/L	R AXZA	L AXZB	X800 X400	13,5	9,0	14,0	9,0	5,3	4,0	D14
3,18	0,2	D14.0318.02 NR/L	R AKAH	L AK9V	X800 X400	13,5	9,0	14,0	9,0	5,3	4,0	D14 <small>inch</small>
▼ ØDmin (Min. Bohrung) // ØDmin (min. bore) = 16,0 mm												
1,5	0,2	D14.0150.02.16 NR/L	R AF0F	L AD21	X800 X400	15,0	9,0	16,0	10,5	5,2	5,5	D14
2,0	0,2	D14.0200.02.16 NR/L	R AMEQ	L ACFH	X800 X400	15,0	9,0	16,0	10,5	5,2	5,5	D14
2,5	0,2	D14.0250.02.16 NR/L	R APQF	L AN8D	X800 X400	15,0	9,0	16,0	10,5	5,2	5,5	D14
3,0	0,2	D14.0300.02.16 NR/L	R AD8X	L ANVS	X800 X400	15,0	9,0	16,0	10,5	5,2	5,5	D14
▼ ØDmin (Min. Bohrung) // ØDmin (min. bore) = 17,0 mm												
2,388	0,2	D14.0238.02 NR/L	R AD4A	L AM2Z	X800 X400	16,0	9,0	17,0	11,5	5,5	6,5	D14 <small>inch new</small>

Verwandte Werkzeuge finden Sie auch auf der folgenden Seite! Related items can be found on the following page as well!

Fortgesetzte Tabelle Continued Table ▶

Bestellbeispiel // Order example: **D14.0250.02 NR X800** (R = Rechte Ausführung // Right hand version, X800 = Schneidstoff // Grade)

Einstecken und Profildrehen

Geeignet ab Bohrungsdurchmesser 16,0 mm.

Grooving and Profiling

For use in bores as of minimum bore diameter 16,0 mm.

Schnittwerte (Start) // Cutting parameters (start)	
f	Vc
0,02 mm/U	Seite/Page 429

Passende Klemmhalter auf Seite // Suitable toolholders on page
158, 159, 160, 161, 163, 164

SP

HM

R

Legende
Legend **213**

Scan
QR-Code Oder besuchen Sie // Or Visit
www.simtek.info/cp/1064

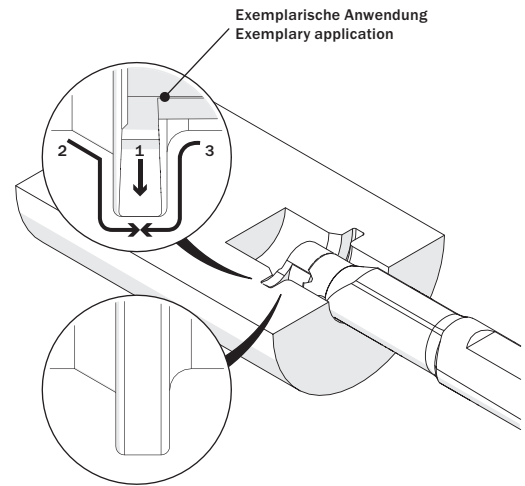
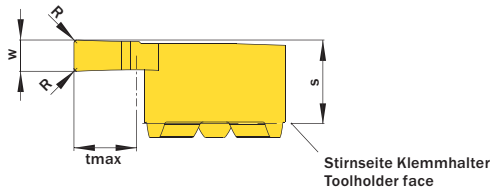
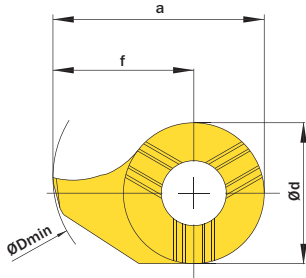


Abbildung zeigt / Drawing shows: D14.0200.02 N R

w ^{+0,03}	R	Artikelnummer Part number	Webcode www.simtek.com/webcode	Unsere erste Wahl Our first choice	a	Ød	ØDmin (Min. Bohrung) ØDmin (min. bore)	f	S	tmax	Connectcode www.simtek.com/code
mm	mm		www.simtek.com/webcode	P K M N S	mm	mm	mm	mm	mm	mm	www.simtek.com/code

◀ Fortgesetzte Tabelle Continued Table Verwandte Werkzeuge finden Sie auch auf der vorhergehenden Seite! Related items can be found on the previous page as well!

▼ ØDmin (Min. Bohrung) // ØDmin (min. bore) = 16,0 mm													
0,787	0,2	D16.0078.02 NR/L	R AAAG	L ANS3	X800 X400	15,7	11,0	16,0	10,2	5,4	4,3	D16	Inch
1,575	0,2	D16.0157.02 NR/L	R AK9T	L AD49	X800 X400	15,7	11,0	16,0	10,2	5,4	4,3	D16	Inch
1,575	0,4	D16.0157.04 NR/L	R ACMW	L ACMC	X800 X400	15,7	11,0	16,0	10,2	5,4	4,3	D16	Inch
2,0	0,2	D16.0200.02 NR/L	R AHDV	L ANM7	X800 X400	15,7	11,0	16,0	10,2	5,4	4,3	D16	
▼ ØDmin (Min. Bohrung) // ØDmin (min. bore) = 17,0 mm													
1,5	0,2	D14.0150.02.17 NR/L	R AKT0	L AF42	X800 X400	16,0	9,0	17,0	11,5	5,2	6,5	D14	
2,0	0,2	D14.0200.02.17 NR/L	R ACCZ	L AFWA	X800 X400	16,0	9,0	17,0	11,5	5,2	6,5	D14	
2,388	0,2	D14.0238.02.17 NR		L A6HZ	X800 X400	16,0	9,0	17,0	11,5	5,2	6,5	D14	new Inch
2,5	0,2	D14.0250.02.17 NR/L	R ADHU	L AKNH	X800 X400	16,0	9,0	17,0	11,5	5,2	6,5	D14	
3,0	0,2	D14.0300.02.17 NR/L	R AEWX	L AFYV	X800 X400	16,0	9,0	17,0	11,5	5,2	6,5	D14	
3,175	0,2	D14.0318.02.17 NR		L A4GN	X800 X400	16,0	9,0	17,0	11,5	5,2	6,5	D14	new Inch
▼ ØDmin (Min. Bohrung) // ØDmin (min. bore) = 18,0 mm													
2,0	0,2	D18.0200.02.18 NR/L	R AVSQ	L AVSS	X800 X400	17,5	11,0	18,0	12,0	5,6	6,0	D18	
▼ ØDmin (Min. Bohrung) // ØDmin (min. bore) = 20,0 mm													
1,5	0,2	D18.0150.02.20 NR/L	R AAX4	L AN0H	X800 X400	19,5	11,0	20,0	14,0	5,6	8,0	D18	
2,0	0,2	D18.0200.02.20 NR/L	R ACXQ	L AAWK	X800 X400	19,5	11,0	20,0	14,0	5,6	8,0	D18	
2,5	0,2	D18.0250.02.20 NR/L	R AVVX	L AVVY	X800 X400	19,5	11,0	20,0	14,0	5,6	8,0	D18	
3,0	0,2	D18.0300.02.20 NR/L	R AVV6	L AVV7	X800 X400	19,5	11,0	20,0	14,0	5,6	8,0	D18	
3,175	0,2	D18.0318.02.20 NR/L	R AVV8	L AVV9	X800 X400	19,5	11,0	20,0	14,0	5,6	8,0	D18	Inch
4,0	0,2	D18.0400.02.20 NR/L	R AVWA	L AVWB	X800 X400	19,5	11,0	20,0	14,0	5,6	8,0	D18	
▼ ØDmin (Min. Bohrung) // ØDmin (min. bore) = 22,0 mm													
1,5	0,2	D18.0150.02.22 NR/L	R A1BK	L A1BJ	X800 X400	21,5	11,0	22,0	16,0	5,6	10,0	D18	
2,0	0,2	D18.0200.02.22 NR/L	R A1BN	L A1BM	X800 X400	21,5	11,0	22,0	16,0	5,6	10,0	D18	

Bestellbeispiel // Order example: D16.0200.02 NR X800 (R = Rechte Ausführung // Right hand version, X800 = Schneidstoff // Grade)

Stechen von Vollradiusnuten

Geeignet ab Bohrungsdurchmesser 8,0 mm.

Full Radius Grooving

For use in bores as of minimum bore diameter 8,0 mm.

Schnittwerte (Start) // Cutting parameters (start)

f	Vc
0,02 mm/U	Seite/Page 429

Passende Klemmhalter auf Seite // Suitable toolholders on page
154, 155, 163, 164

SP

HM

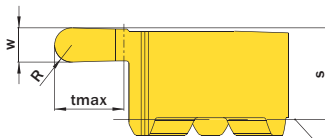
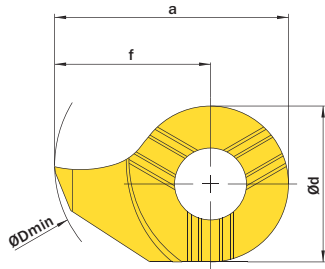
R

Legende
Legend

213

Scan
QR-Code

Oder besuchen Sie // Or Visit
www.simtek.info/cp/830



Stirnseite Klemmhalter
Toolholder face

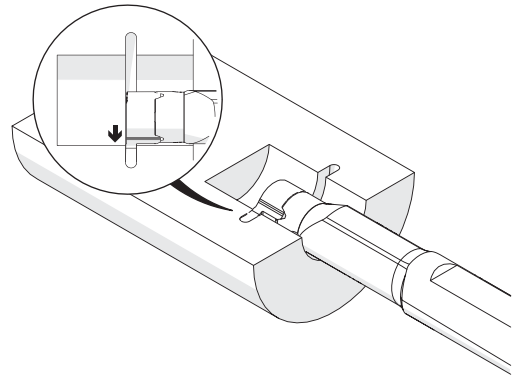


Abbildung zeigt / Drawing shows: D14.0010.20 V R

R	w ^{+0,05}	Artikelnummer Part number	Webcode www.simtek.com/webcode	Unsere erste Wahl Our first choice	a	Ød	ØDmin (Min. Bohrung) ØDmin (min. bore)	s	f	tmax	Connectcode www.simtek.com/code
mm	mm			P K M N S	mm	mm	mm	mm	mm	mm	
▼ ØDmin (Min. Bohrung) // ØDmin (min. bore) = 8,0 mm											
0,4	0,8	D08.0004.08 VR/L	R AAP2 L AE8B	X800 X400	7,8	6,0	8,0	3,3	4,8	1,0	D08
0,6	1,2	D08.0006.12 VR/L	R AHUE L AF16	X800 X400	7,8	6,0	8,0	3,3	4,8	1,0	D08
0,79	1,575	D08.0008.157 VR/L	R A4NH L A4NK	X800 X400	7,8	6,0	8,0	3,3	4,8	1,0	D08 new
0,8	1,6	D08.0008.16 VR/L	R ANWU L AJUP	X800 X400	7,8	6,0	8,0	3,3	4,8	1,0	D08 new
0,9	1,8	D08.0009.18 VR/L	R AMHØ L APZV	X800 X400	7,8	6,0	8,0	3,3	4,8	1,0	D08
1,0	2,0	D08.0010.20 VR/L	R ADYE L AEDC	X800 X400	7,8	6,0	8,0	3,3	4,8	1,0	D08
▼ ØDmin (Min. Bohrung) // ØDmin (min. bore) = 9,0 mm											
0,4	0,8	D09.0004.08.09 VR/L	R AFFF L AWGW	X800 X400	8,6	6,2	9,0	3,5	5,5	1,6	D09
0,5	1,0	D09.0005.10.09 VR/L	R A5WV L A5W3	X800 X400	8,6	6,2	9,0	3,5	5,5	1,6	D09 new
0,6	1,2	D09.0006.12.09 VR/L	R AFWG L AWGX	X800 X400	8,6	6,2	9,0	3,5	5,5	1,6	D09
0,9	1,8	D09.0009.18.09 VR/L	R AWFH L AWGY	X800 X400	8,6	6,2	9,0	3,5	5,5	1,6	D09
1,0	2,0	D09.0010.20.09 VR/L	R AWFJ L AWGZ	X800 X400	8,6	6,2	9,0	3,5	5,5	1,6	D09

Verwandte Werkzeuge finden Sie auch auf der folgenden Seite!
Related items can be found on the following page as well!

Fortgesetzte Tabelle
Continued Table ▶

Bestellbeispiel // Order example: **D08.0004.08 VR X800** (R = Rechte Ausführung // Right hand version, X800 = Schneidstoff // Grade)

Stechen von Vollradiusnuten

Geeignet ab Bohrungsdurchmesser 10,0 mm.

Full Radius Grooving

For use in bores as of minimum bore diameter 10,0 mm.

Schnittwerte (Start) // Cutting parameters (start)	
f	Vc
0,02 mm/U	Seite/Page 429

Passende Klemmhalter auf Seite // Suitable toolholders on page
156, 157, 161, 163, 164

SP **HM** **R** Legende Legend **213**

Scan QR-Code Oder besuchen Sie // Or Visit www.simtek.info/cp/1342

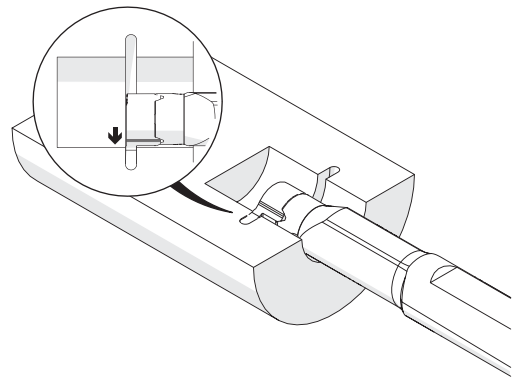
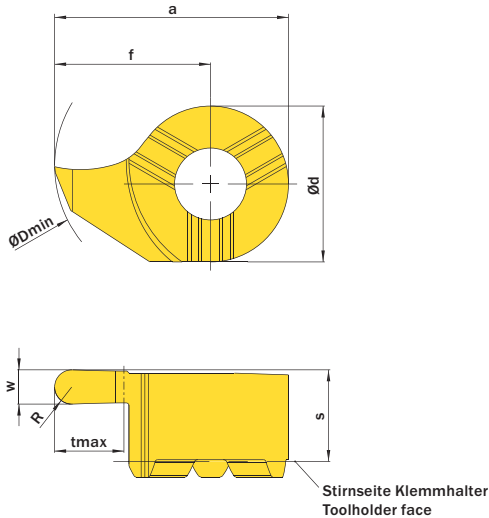


Abbildung zeigt / Drawing shows: D14.0010.20 V R

R	w ^{+0,05}	Artikelnummer Part number	Webcode www.simtek.com/webcode	Unsere erste Wahl Our first choice	a	Ød	ØDmin (Min. Bohrung) ØDmin (min. bore)	S	f	tmax	Connectcode www.simtek.com/ccode
mm	mm			P K M N S	mm	mm	mm	mm	mm	mm	
▼ ØDmin (Min. Bohrung) // ØDmin (min. bore) = 10,0 mm											
0,4	0,8	D10.0004.08.10 VR/L	R AD9G L AECX	X800 X400	9,3	7,0	10,0	3,9	5,8	1,8	D10
0,5	1,0	D10.0005.10.10 VR	A5DK	X800 X400	9,3	7,0	10,0	3,9	5,8	1,8	D10 new
0,6	1,2	D10.0006.12.10 VR/L	R ABMC L ANBF	X800 X400	9,3	7,0	10,0	3,9	5,8	1,8	D10
0,9	1,8	D10.0009.18.10 VR/L	R AC50 L AFQ8	X800 X400	9,3	7,0	10,0	3,9	5,8	1,8	D10
1,0	2,0	D10.0010.20.10 VR/L	R AAK8 L ABVA	X800 X400	9,3	7,0	10,0	3,9	5,8	1,8	D10
▼ ØDmin (Min. Bohrung) // ØDmin (min. bore) = 11,0 mm											
0,4	0,8	D11.0004.08 VR/L	R AJS6 L AGJD	X800 X400	10,7	8,0	11,0	4,2	6,7	2,3	D11
0,584	1,168	D11.0006.117 VR	A6D7	X800 X400	10,7	8,0	11,0	4,2	6,7	2,3	D11 new inch
0,6	1,2	D11.0006.12 VR/L	R AH9B L AE6K	X800 X400	10,7	8,0	11,0	4,2	6,7	2,3	D11
0,787	1,575	D11.0008.157 VR	A6D5	X800 X400	10,7	8,0	11,0	4,2	6,7	2,3	D11 new inch
0,8	1,6	D11.0008.16 VR/L	R AMJP L AP28	X800 X400	10,7	8,0	11,0	4,2	6,7	2,3	D11
0,9	1,8	D11.0009.18 VR/L	R APTS L AA18	X800 X400	10,7	8,0	11,0	4,2	6,7	2,3	D11
1,0	2,0	D11.0010.20 VR/L	R AC6N L ABQC	X800 X400	10,7	8,0	11,0	4,2	6,7	2,3	D11
1,2	2,4	D11.0012.24 VR/L	R AF3Y L AKC8	X800 X400	10,7	8,0	11,0	4,2	6,7	2,3	D11
1,5	3,0	D11.0015.30 VR/L	R AFGU L AKX2	X800 X400	10,7	8,0	11,0	4,2	6,7	2,3	D11

Bestellbeispiel // Order example: **D11.0015.30 VR X800** (R = Rechte Ausführung // Right hand version, X800 = Schneidstoff // Grade)

simturn AX
simturn DX
simturn PX
simturn H2
simturn K2
simturn C4
simturn GX
simturn E3
simturn E12
simturn FX
simturn Decolletage
simturn OA
Index

Stechen von Vollradiusnuten

Geeignet ab Bohrungsdurchmesser 14,0 mm.

Full Radius Grooving

For use in bores as of minimum bore diameter 14,0 mm.

Schnittwerte (Start) // Cutting parameters (start)	
f	Vc
0,02 mm/U	Seite/Page 429

Passende Klemmhalter auf Seite // Suitable toolholders on page
158, 161, 164

SP

HM

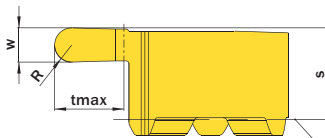
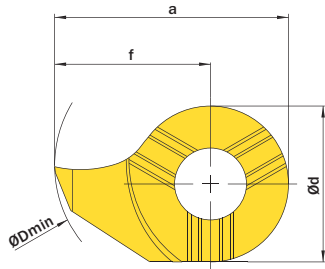
R

Legende
Legend

213

Scan
QR-Code

Oder besuchen Sie // Or Visit
www.simtek.info/cp/846



Stirnseite Klemmhalter
Toolholder face

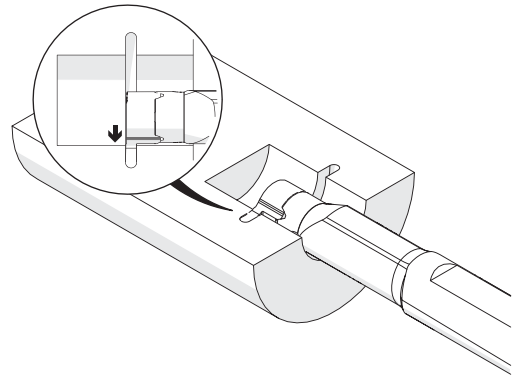


Abbildung zeigt / Drawing shows: D14.0010.20 V R

R	w ^{+0,05}	Artikelnummer Part number	Webcode www.simtek.com/webcode	Unsere erste Wahl Our first choice	a	Ød	ØDmin (Min. Bohrung) ØDmin (min. bore)	S	f	tmax	Connectcode www.simtek.com/ccode
mm	mm		www.simtek.com/webcode	P K M N S	mm	mm	mm	mm	mm	mm	www.simtek.com/ccode

Fortgesetzte Tabelle
Continued Table

Verwandte Werkzeuge finden Sie auch auf der vorhergehenden Seite!
Related Items can be found on the previous page as well!

0,4	0,8	D14.0004.08 VR/L	R AFZD L AHT8	X800 X400	13,5	9,0	14,0	5,2	9,0	4,0	D14
0,5	1,0	D14.0005.10 VR/L	R A5WX L A5W5	X800 X400	13,5	9,0	14,0	5,3	9,0	4,0	D14 new
0,6	1,2	D14.0006.12 VR/L	R ADBN L AHHJ	X800 X400	13,5	9,0	14,0	5,3	9,0	4,0	D14
0,8	1,6	D14.0008.16 VR/L	R ABBY L ABFC	X800 X400	13,5	9,0	14,0	5,3	9,0	4,0	D14
0,9	1,8	D14.0009.18 VR/L	R AESX L AEGW	X800 X400	13,5	9,0	14,0	5,3	9,0	4,0	D14
1,0	2,0	D14.0010.20 VR/L	R AGHK L AJYS	X800 X400	13,5	9,0	14,0	5,3	9,0	4,0	D14
1,1	2,2	D14.0011.22 VR/L	R AKS8 L ANBN	X800 X400	13,5	9,0	14,0	5,3	9,0	4,0	D14
1,2	2,4	D14.0012.24 VR/L	R ACK4 L AM96	X800 X400	13,5	9,0	14,0	5,3	9,0	4,0	D14
1,5	3,0	D14.0015.30 VR/L	R AKKQ L APW7	X800 X400	13,5	9,0	14,0	5,3	9,0	4,0	D14
0,79	1,575	D14.0031.62 VR	A2VM	X800 X400	13,5	9,0	14,0	5,3	9,0	4,0	D14 inch
1,59	3,175	D14.0062.12 VR/L	R A2VN L A339	X800 X400	13,5	9,0	14,0	5,3	9,0	4,0	D14 new inch

Verwandte Werkzeuge finden Sie auch auf der folgenden Seite!
Related Items can be found on the following page as well!

Fortgesetzte Tabelle
Continued Table

Bestellbeispiel // Order example: **D14.0015.30 VR X800** (R = Rechte Ausführung // Right hand version, X800 = Schneidstoff // Grade)

Stechen von Vollradiusnuten

Geeignet ab Bohrungsdurchmesser 16,0 mm.

Full Radius Grooving

For use in bores as of minimum bore diameter 16,0 mm.

Schnittwerte (Start) // Cutting parameters (start)	
f	Vc
0,02 mm/U	Seite/Page 429

Passende Klemmhalter auf Seite // Suitable toolholders on page
159, 160, 163, 164

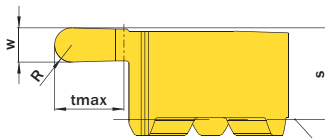
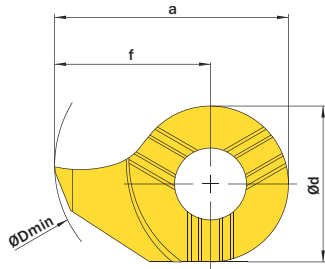
SP
CBN

SP
HM

R

Legende
Legend **213**

Scan
QR-Code Oder besuchen Sie // Or Visit
www.simtek.info/cp/1332



Stirnseite Klemmhalter
Toolholder face

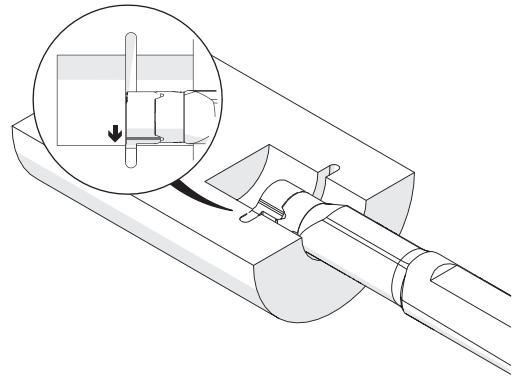


Abbildung zeigt / Drawing shows: D14.0010.20 V R

R	w ^{+0,05}	Artikelnummer Part number	Webcode www.simtek.com/webcode	Unsere erste Wahl Our first choice	a	Ød	ØDmin (Min. Bohrung) ØDmin (min. bore)	S	f	tmax	Connectcode www.simtek.com/ccode
mm	mm		www.simtek.com/webcode	P K M N S	mm	mm	mm	mm	mm	mm	www.simtek.com/ccode

Fortgesetzte Tabelle // Continued Table **Verwandte Werkzeuge finden Sie auch auf der vorhergehenden Seite!**
Related items can be found on the previous page as well!

▼ ØDmin (Min. Bohrung) // ØDmin (min. bore) = 16,0 mm											
0,8	1,6	D16.0008.16 VR/L	R AFK1 L AM7T	X800 X400	15,7	11,0	16,0	5,4	10,2	4,3	D16
0,9	1,8	D16.0009.18 VR/L	R AMCU L ABQE	X800 X400	15,7	11,0	16,0	5,4	10,2	4,3	D16
0,991	1,981	D16.0010.198 VR	A6E7	X800 X400	15,7	11,0	16,0	5,4	10,2	4,3	D16 new inch
1,0	2,0	D16.0010.20 VR/L	R AKNU L AJWC	X800 X400	15,7	11,0	16,0	5,4	10,2	4,3	D16
1,1	2,2	D16.0011.22 VR/L	R AD51 L ABHK	X800 X400	15,7	11,0	16,0	5,4	10,2	4,3	D16
1,2	2,4	D16.0012.24 VR/L	R AJJS L APFØ	X800 X400	15,7	11,0	16,0	5,4	10,2	4,3	D16
1,5	3,0	D16.0015.30 VR/L	R AJA7 L AE92	X800 X400	15,7	11,0	16,0	5,4	10,2	4,3	D16
1,6	3,2	D16.0016.32 VR/L	R AGCX L AJK3	X800 X400	15,7	11,0	16,0	5,4	10,2	4,3	D16
2,0	4,0	D16.0020.40 VR/L	R APN4 L AHYY	X800 X400	15,7	11,0	16,0	5,4	10,2	4,3	D16
0,787	1,575	D16.0031.62 VR	A2VK	X800 X400	15,7	11,0	16,0	5,4	10,2	4,3	D16 inch
1,575	3,175	D16.0062.12 VR	A2BP	X800 X400	15,7	11,0	16,0	5,4	10,2	4,3	D16 inch
▼ ØDmin (Min. Bohrung) // ØDmin (min. bore) = 18,0 mm											
0,9	1,8	D18.0009.18.18 VR/L	R AVD9 L AVEA	X800 X400	17,5	11,0	18,0	5,6	12,0	6,0	D18
1,1	2,2	D18.0011.22.18 VR/L	R AVEB L AVEC	X800 X400	17,5	11,0	18,0	5,6	12,0	6,0	D18
1,19	2,38	D18.0012.238.18 VR	A6J5	X800 X400	17,5	11,0	18,0	5,6	12,0	6,0	D18 new inch
1,5	3,0	D18.0015.30.18 VR/L	R AVEE L AVED	X800 X400	17,5	11,0	18,0	5,6	12,0	6,0	D18
1,6	3,2	D18.0016.32.18 VR/L	R AV6T L AV6S	X800 X400	17,5	11,0	18,0	5,6	12,0	6,0	D18
2,0	4,0	D18.0020.40.18 VR/L	R AV6U L AV6V	X800 X400	17,5	11,0	18,0	5,6	12,0	6,0	D18

Bestellbeispiel // Order example: **D16.0008.16 VR X800** (R = Rechte Ausführung // Right hand version, X800 = Schneidstoff // Grade)

simturn AX
simturn DX
simturn PX
simturn H2
simturn K2
simturn C4
simturn GX
simturn E3
simturn E12
simturn FX
simturn Decolletage
simturn OA
Index

Vorstechen und Fasen

Geeignet ab Bohrungsdurchmesser 8,0 mm.

Pre-Part-Off and Chamfering

For use in bores as of minimum bore diameter 8,0 mm.

Schnittwerte (Start) // Cutting parameters (start)

f	Vc
0,02 mm/U	Seite/Page 429

Passende Klemmhalter auf Seite // Suitable toolholders on page

154, 155, 156, 157, 158, 159, 161, 163, 164



Legende
Legend 213



Oder besuchen Sie // Or Visit
www.simtek.info/cp/831

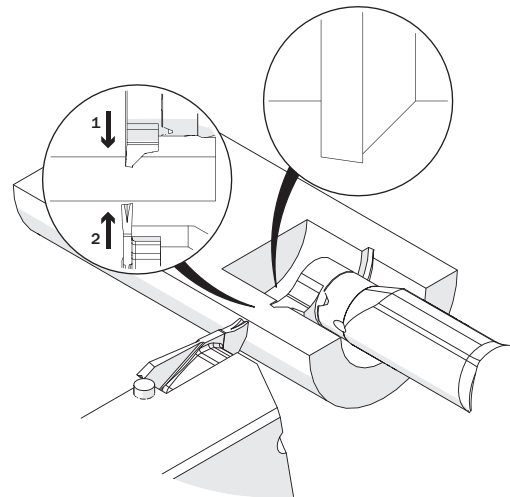
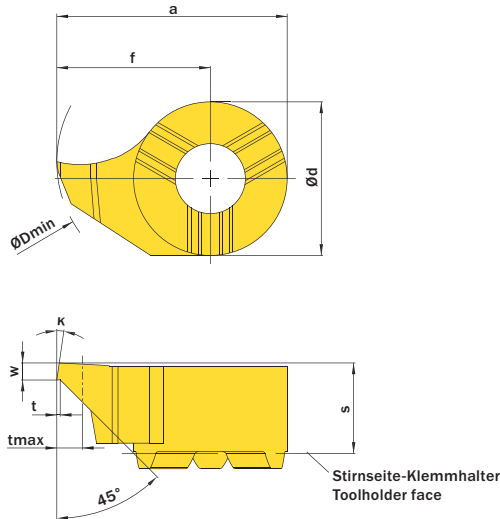


Abbildung zeigt / Drawing shows: D14.0810.00 P R

K	w mm	Artikelnummer Part number	Webcode www.simtek.com/webcode	Unsere erste Wahl Our first choice	a	Ød	ØDmin (Min. Bohrung) ØDmin (min. bore)	f	S	t	tmax	Connectcode www.simtek.com/code
▼ ØDmin (Min. Bohrung) // ØDmin (min. bore) = 8,0 mm												
8°	1,0	D08.0810.00 PR/L	R AJ7Z L AD30	X800 X400	7,8	6,0	8,0	4,8	3,3	0,2	1,0	D08
▼ ØDmin (Min. Bohrung) // ØDmin (min. bore) = 9,0 mm												
8°	1,0	D09.0810.00.09 PR/L	R AWF9 L AWHP	X800 X400	8,6	6,2	9,0	5,5	3,6	0,2	1,5	D09
▼ ØDmin (Min. Bohrung) // ØDmin (min. bore) = 10,0 mm												
8°	1,0	D10.0810.00.10 PR/L	R AHZ3 L APNG	X800 X400	9,3	7,0	10,0	5,8	3,9	0,2	1,5	D10
▼ ØDmin (Min. Bohrung) // ØDmin (min. bore) = 11,0 mm												
8°	1,0	D11.0810.00 PR/L	R AFDK L AB2C	X800 X400	10,7	8,0	11,0	6,7	4,2	0,2	1,5	D11
8°	1,5	D11.0815.00 PR/L	R AK9Z L AA76	X800 X400	10,7	8,0	11,0	6,7	4,2	0,2	1,5	D11
▼ ØDmin (Min. Bohrung) // ØDmin (min. bore) = 14,0 mm												
8°	1,0	D14.0810.00 PR/L	R AH2J L AE1N	X800 X400	13,5	9,0	14,0	9,0	5,3	0,2	1,5	D14
8°	1,5	D14.0815.00 PR/L	R AEQG L AHY9	X800 X400	13,5	9,0	14,0	9,0	5,3	0,2	1,5	D14
▼ ØDmin (Min. Bohrung) // ØDmin (min. bore) = 16,0 mm												
8°	1,0	D16.0810.00 PR/L	R AHPB L AADS	X800 X400	15,7	11,0	16,0	10,2	5,4	0,2	1,5	D16
8°	1,5	D16.0815.00 PR/L	R AAHN L ANXC	X800 X400	15,7	11,0	16,0	10,2	5,4	0,2	1,5	D16

Bestellbeispiel // Order example: **D11.0810.00 PR X800** (R = Rechte Ausführung // Right hand version, X800 = Schneidstoff // Grade)

Gewindedrehen, Metrisches ISO Vollprofil

Herstellung des vollständigen Gewindeprofils mit erforderlicher Tiefe.

Threading, Metric ISO Full Profile

For a complete thread profile with correct depth.

Schnittwerte (Start) // Cutting parameters (start)
Anzahl Durchgänge // Number of passes 10 - 16
Empf. Zustellungsart // Recom. infeed method Flankenzustellung // Flank infeed (Seite/Page 433)
Vc Seite/Page 429

Passende Klemmhalter auf Seite // Suitable toolholders on page
155, 156, 157, 161, 163, 164

SP

HM

R

Legende
Legend **213**

Scan
QR-Code Oder besuchen Sie // Or Visit
www.simtek.info/cp/823

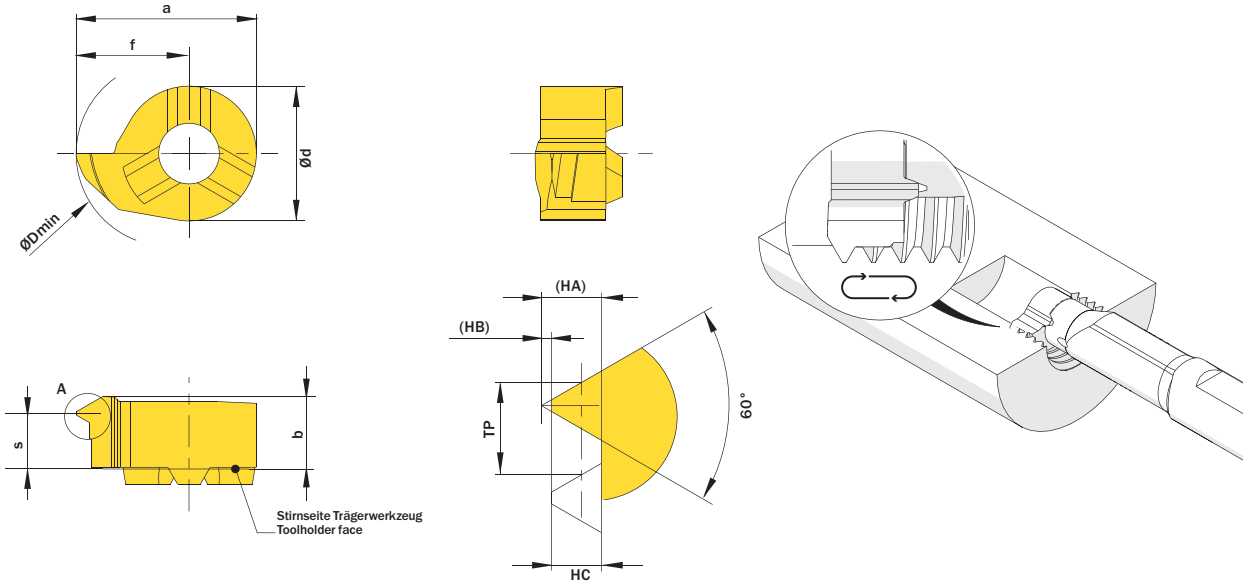


Abbildung zeigt / Drawing shows: D11.0815.02 MR

HC	Steigung TP Pitch TP	Artikelnummer Part number	Webcode www.simtek.com/webcode	Unsere erste Wahl Our first choice					a	b	Ød	HA	HB	ØDmin (Min. Bohrung) ØDmin (min. bore)	f	S	Connectcode www.simtek.com/code
				P	K	M	N	S									
▼ ØDmin (Min. Bohrung) // ØDmin (min. bore) = 9,0 mm																	
0,271	0,5	D09.0205.02.09 MR/L	R AWGT	L AWH6	X800	X400	8,6	3,65	6,2	0,325	0,054	9,0	5,5	3,25	D09	upd	
0,541	1,0	D09.0510.02.09 MR/L	R AWGS	L AWH5	X800	X400	8,6	3,65	6,2	0,65	0,108	9,0	5,5	3,0	D09	upd	
0,812	1,5	D09.0815.02.09 MR/L	R AWGQ	L AWH4	X800	X400	8,6	3,6	6,2	0,974	0,162	9,0	5,5	2,8	D09	upd	
0,947	1,75	D09.0917.02.09 MR/L	R AWGP	L AWH3	X800	X400	8,6	3,6	6,2	1,137	0,189	9,0	5,5	2,7	D09	upd	
1,083	2,0	D09.1020.02.09 MR/L	R AWGN	L AWH2	X800	X400	8,6	3,58	6,2	1,299	0,217	9,0	5,5	2,6	D09	upd	
1,353	2,5	D09.1325.02.09 MR/L	R AWGM	L AWH1	X800	X400	8,6	3,56	6,2	1,624	0,271	9,0	5,5	2,5	D09	upd	
1,624	3,0	D09.1630.02.09 MR/L	R AWGK	L AWH0	X800	X400	8,6	3,54	6,2	1,949	0,325	9,0	5,5	2,2	D09	upd	
▼ ØDmin (Min. Bohrung) // ØDmin (min. bore) = 10,0 mm																	
0,271	0,5	D10.0205.02.10 MR/L	R ANVA	L ADJC	X800	X400	9,3	3,8	7,0	0,325	0,054	10,0	5,8	3,4	D10	upd	
0,541	1,0	D10.0510.02.10 MR/L	R ANP1	L ADAV	X800	X400	9,3	4,0	7,0	0,65	0,108	10,0	5,8	3,2	D10	upd	
0,812	1,5	D10.0815.02.10 MR/L	R AM2E	L AA2U	X800	X400	9,3	3,9	7,0	0,974	0,162	10,0	5,8	3,0	D10	upd	
0,947	1,75	D10.0917.02.10 MR/L	R AD6Z	L ABYB	X800	X400	9,3	3,9	7,0	1,137	0,189	10,0	5,8	2,9	D10	upd	
1,083	2,0	D10.1020.02.10 MR/L	R AADQ	L AKFM	X800	X400	9,3	3,9	7,0	1,299	0,217	10,0	5,8	2,75	D10	upd	
1,353	2,5	D10.1325.02.10 MR/L	R AAG5	L AMY3	X800	X400	9,3	3,8	7,0	1,624	0,271	10,0	5,8	2,5	D10	upd	
1,624	3,0	D10.1630.02.10 MR/L	R AJXD	L AKWA	X800	X400	9,3	3,8	7,0	1,949	0,325	10,0	5,8	2,45	D10	upd	
▼ ØDmin (Min. Bohrung) // ØDmin (min. bore) = 11,0 mm																	
0,541	1,0	D11.0510.02 MR/L	R AJ3B	L AF7P	X800	X400	10,7	4,3	8,0	0,65	0,108	11,0	6,7	3,6	D11	upd	
0,812	1,5	D11.0815.02 MR/L	R AESU	L APF7	X800	X400	10,7	4,3	8,0	0,974	0,162	11,0	6,7	3,3	D11	upd	
1,083	2,0	D11.1020.02 MR/L	R AF4G	L ACVY	X800	X400	10,7	4,3	8,0	1,299	0,217	11,0	6,7	2,9	D11	upd	
1,353	2,5	D11.1325.02 MR/L	R AN9M	L ACTN	X800	X400	10,7	4,3	8,0	1,624	0,271	11,0	6,7	2,95	D11	upd	
1,624	3,0	D11.1630.02 MR/L	R AKVC	L AJZG	X800	X400	10,7	4,3	8,0	1,949	0,325	11,0	6,7	2,9	D11	upd	

Verwandte Werkzeuge finden Sie auch auf der folgenden Seite!
Related Items can be found on the following page as well!

Fortgesetzte Tabelle
Continued Table

Bestellbeispiel // Order example: **D11.1020.02 MR X800** (R = Rechte Ausführung // Right hand version, X800 = Schneidstoff // Grade)

Gewindedrehen, Metrisches ISO Vollprofil

Herstellung des vollständigen Gewindeprofils mit erforderlicher Tiefe.

Threading, Metric ISO Full Profile

For a complete thread profile with correct depth.

Schnittwerte (Start) // Cutting parameters (start)
Anzahl Durchgänge // Number of passes 10 - 16
Empf. Zustellungsart // Recom. infeed method Flankenzustellung // Flank infeed (Seite/Page 433)
Vc Seite/Page 429

Passende Klemmhalter auf Seite // Suitable toolholders on page
158, 159, 161, 163, 164



Legende
Legend **213**



Scan
QR-Code

Oder besuchen Sie // Or Visit
www.simtek.info/cp/882

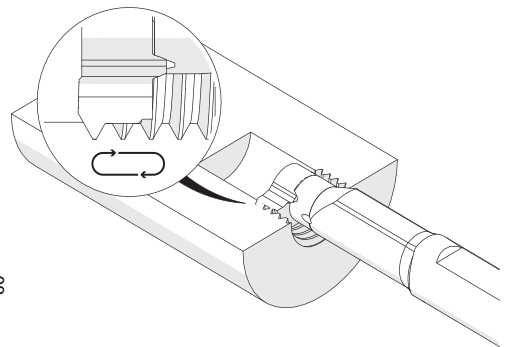
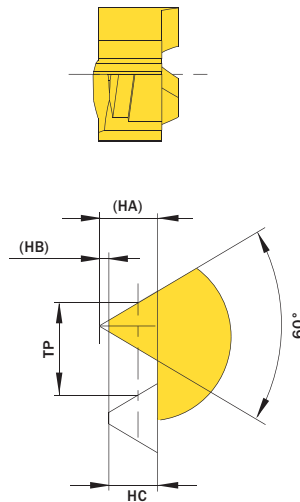
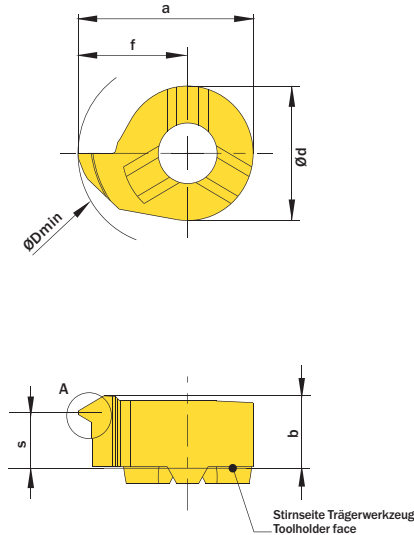


Abbildung zeigt / Drawing shows: D11.0815.02 MR

HC	Steigung TP Pitch TP	Artikelnummer Part number	Webcode www.simtek.com/webcode	Unsere erste Wahl Our first choice	a	b	HA	HB	Ød	Ødmin (Min. Bohrung) Ødmin (min. bore)	f	S	Connectcode www.simtek.com/code
mm	mm			P K M N S	mm	mm	mm	mm	mm	mm	mm	mm	

Fortgesetzte Tabelle Continued Table **Verwandte Werkzeuge finden Sie auch auf der vorhergehenden Seite!**
Related items can be found on the previous page as well!

▼ Ødmin (Min. Bohrung) // Ødmin (min. bore) = 14,0 mm														
0,271	0,5	D14.0205.02 MR/L	R AG11 L AAM6	X800 X400	13,5	5,4	0,325	0,054	9,0	14,0	9,0	4,8	D14	upd
0,541	1,0	D14.0510.02 MR/L	R AGVA L AN3Z	X800 X400	13,5	5,4	0,65	0,108	9,0	14,0	9,0	4,7	D14	upd
0,812	1,5	D14.0815.02 MR/L	R AAPD L AHEZ	X800 X400	13,5	5,4	0,974	0,162	9,0	14,0	9,0	4,3	D14	upd
1,083	2,0	D14.1020.02 MR/L	R ABSD L AMJS	X800 X400	13,5	5,4	1,299	0,217	9,0	14,0	9,0	4,2	D14	upd
1,353	2,5	D14.1325.02 MR/L	R AFMØ L APW6	X800 X400	13,5	5,4	1,624	0,271	9,0	14,0	9,0	3,65	D14	upd
▼ Ødmin (Min. Bohrung) // Ødmin (min. bore) = 16,0 mm														
0,541	1,0	D16.0510.02 MR/L	R ACØ7 L ACXP	X800 X400	15,7	5,5	0,65	0,108	11,0	16,0	10,2	4,8	D16	upd
0,812	1,5	D16.0815.02 MR/L	R ADSQ L AGTH	X800 X400	15,7	5,5	0,974	0,162	11,0	16,0	10,2	4,3	D16	upd
1,083	2,0	D16.1020.02 MR/L	R AHC8 L ANXE	X800 X400	15,7	5,5	1,299	0,217	11,0	16,0	10,2	4,05	D16	upd
1,353	2,5	D16.1325.02 MR/L	R AMW1 L AG5U	X800 X400	15,7	5,5	1,624	0,271	11,0	16,0	10,2	4,2	D16	upd
1,624	3,0	D16.1630.02 MR/L	R AKHY L AN34	X800 X400	15,7	5,5	1,949	0,325	11,0	16,0	10,2	4,0	D16	upd
1,894	3,5	D16.1835.02 MR/L	R AANW L AG41	X800 X400	15,7	5,5	2,273	0,379	11,0	16,0	10,2	3,9	D16	upd
2,165	4,0	D16.2140.02 MR/L	R AD32 L AEED	X800 X400	15,7	5,5	2,598	0,433	11,0	16,0	10,2	3,6	D16	upd

Bestellbeispiel // Order example: **D14.0815.02 MR X800** (R = Rechte Ausführung // Right hand version, X800 = Schneidstoff // Grade)

Gewindedrehen, Metrisches ISO Teilprofil

Mehrbereichswerkzeuge für verschiedene Steigungen.

Threading, Metric ISO Partial Profile

Multi-purpose tools, usable for different pitches.

Schnittwerte (Start) // Cutting parameters (start)
Anzahl Durchgänge // Number of passes 10 - 16
Empf. Zustellungsart // Recom. infeed method Flankenzustellung // Flank infeed (Seite/Page 433)
Vc Seite/Page 429
Passende Klemmhalter auf Seite // Suitable toolholders on page 153, 154, 155, 156, 161, 162, 163, 164
Bitte Hinweise im Anhang beachten // Please read add. notes T01 (Seite/Page 212)

SP
HM
R

Legende
Legend **213**

Scan
QR-Code

Oder besuchen Sie // Or Visit
www.simtek.info/cp/822

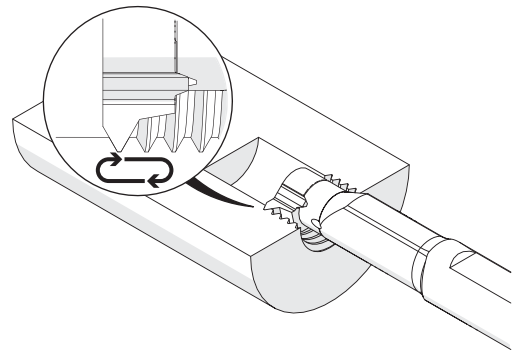
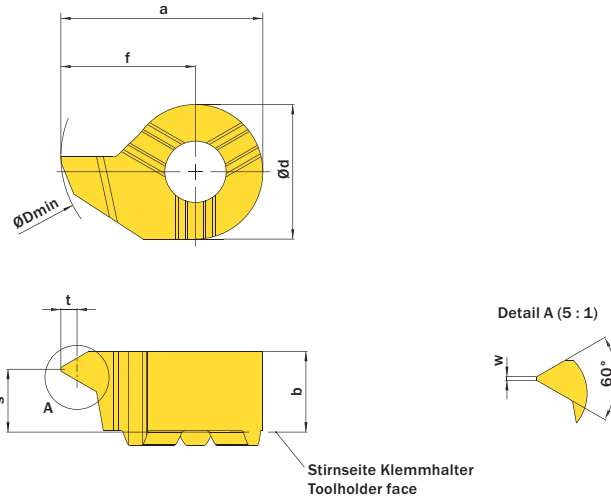


Abbildung zeigt / Drawing shows: D14.1020.01 M R

Steigung (von) Pitch (as of)	Steigung (bis) Pitch (up to)	Artikelnummer Part number	Webcode www.simtek.com/webcode	Unsere erste Wahl Our first choice					a	t	b	Ød	ØDmin (Min. Bohrung) ØDmin (min. bore)	f	S	w	Connectcode www.simtek.com/code
				P	K	M	N	S									
▼ ØDmin (Min. Bohrung) // ØDmin (min. bore) = 7,0 mm																	
0,5	0,75	D07.MT05.01.07 MR/L	R AU57	L AXBC	X800	X400	6,55	0,44	3,3	4,8	7,0	4,15	2,9	0,06		D07	
1,0	1,25	D07.MT10.01.07 MR/L	R AU59	L AXBD	X800	X400	6,2	0,7	3,3	4,8	7,0	3,8	2,7	0,12		D07	
1,5	1,75	D07.MT15.01.07 MR/L	R AU58	L AXBE	X800	X400	6,55	0,97	3,3	4,8	7,0	4,15	2,5	0,18		D07	
▼ ØDmin (Min. Bohrung) // ØDmin (min. bore) = 8,0 mm																	
0,5	0,75	D08.0205.01 MR/L	R ANP8	L AEEG	X800	X400	7,8	0,43	3,4	6,0	8,0	4,8	2,95	0,06		D08	
1,0	1,25	D08.0510.01 MR/L	R AG0B	L AC5F	X800	X400	7,8	0,7	3,4	6,0	8,0	4,8	2,7	0,12		D08	
1,5	1,75	D08.0815.01 MR/L	R AB62	L ACGW	X800	X400	7,8	0,98	3,4	6,0	8,0	4,8	2,5	0,18		D08	
▼ ØDmin (Min. Bohrung) // ØDmin (min. bore) = 9,0 mm																	
0,5	0,75	D09.0205.01.09 MR/L	R AWGG	L AWHX	X800	X400	8,6	0,44	3,55	6,2	9,0	5,5	3,2	0,06		D09	
1,0	1,25	D09.0510.01.09 MR/L	R AWGF	L AHHW	X800	X400	8,6	0,54	3,55	6,2	9,0	5,5	3,0	0,12		D09	
1,5	1,75	D09.0815.01.09 MR/L	R AWGE	L AWHV	X800	X400	8,6	0,81	3,55	6,2	9,0	5,5	2,8	0,18		D09	
1,75	2,0	D09.0917.01.09 MR/L	R AWGD	L AWHU	X800	X400	8,6	0,95	3,55	6,2	9,0	5,5	2,6	0,2		D09	
2,0	2,5	D09.1020.01.09 MR/L	R AWGC	L AWHI	X800	X400	8,6	1,08	3,55	6,2	9,0	5,5	2,5	0,25		D09	
2,5	3,0	D09.1325.01.09 MR/L	R AWGB	L AWHJ	X800	X400	8,6	1,35	3,55	6,2	9,0	5,5	2,1	0,31		D09	
3,0	3,5	D09.1630.01.09 MR/L	R AWGA	L AWHQ	X800	X400	8,6	1,62	3,55	6,2	9,0	5,5	1,9	0,37		D09	
▼ ØDmin (Min. Bohrung) // ØDmin (min. bore) = 10,0 mm																	
0,5	0,75	D10.0205.01.10 MR/L	R AMAT	L AGSC	X800	X400	9,3	0,44	4,0	7,0	10,0	5,8	3,4	0,06		D10	
1,0	1,25	D10.0510.01.10 MR/L	R ADPE	L AC1S	X800	X400	9,3	0,54	4,0	7,0	10,0	5,8	3,2	0,12		D10	
1,5	1,75	D10.0815.01.10 MR/L	R AKN5	L AGUX	X800	X400	9,3	0,81	4,0	7,0	10,0	5,8	3,0	0,18		D10	
1,75	2,0	D10.0917.01.10 MR/L	R AEBW	L AFX7	X800	X400	9,3	0,95	4,0	7,0	10,0	5,8	2,9	0,21		D10	
2,0	2,5	D10.1020.01.10 MR/L	R ACUA	L AKXX	X800	X400	9,3	1,08	3,9	7,0	10,0	5,8	2,75	0,25		D10	
2,5	3,0	D10.1325.01.10 MR/L	R AMF8	L AN76	X800	X400	9,3	1,35	3,8	7,0	10,0	5,8	2,55	0,31		D10	
3,0	3,5	D10.1630.01.10 MR/L	R AH96	L ACJE	X800	X400	9,3	1,62	4,0	7,0	10,0	5,8	2,3	0,37		D10	

Verwandte Werkzeuge finden Sie auch auf der folgenden Seite!
Related items can be found on the following page as well!

Fortgesetzte Tabelle
Continued Table

Bestellbeispiel // Order example: **D08.0510.01 MR X800** (R = Rechte Ausführung // Right hand version, X800 = Schneidstoff // Grade)

Bitte beachten Sie die zusätzlichen Hinweise im Infobereich rechts oben.
Please read the additional notes mentioned in the information area on the top right corner of this page.

Gewindedrehen, Metrisches ISO Teilprofil

Mehrbereichswerkzeuge für verschiedene Steigungen.

Threading, Metric ISO Partial Profile

Multi-purpose tools, usable for different pitches.

Schnittwerte (Start) // Cutting parameters (start)
Anzahl Durchgänge // Number of passes 10 - 16
Empf. Zustellungsart // Recom. infeed method Flankenzustellung // Flank infeed (Seite/Page 433)
Vc Seite/Page 429

Passende Klemmhalter auf Seite // Suitable toolholders on page
157, 158, 159, 161, 163, 164

SP

HM

R

Legende
Legend **213**

Scan
QR-Code

Oder besuchen Sie // Or Visit
www.simtek.info/cp/881

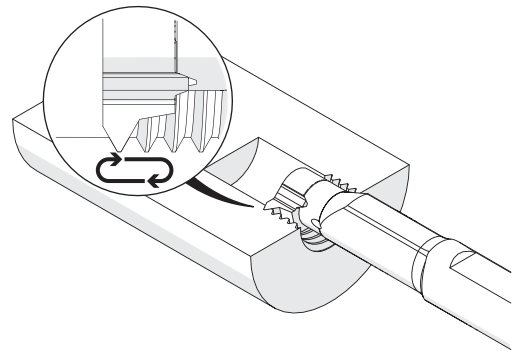
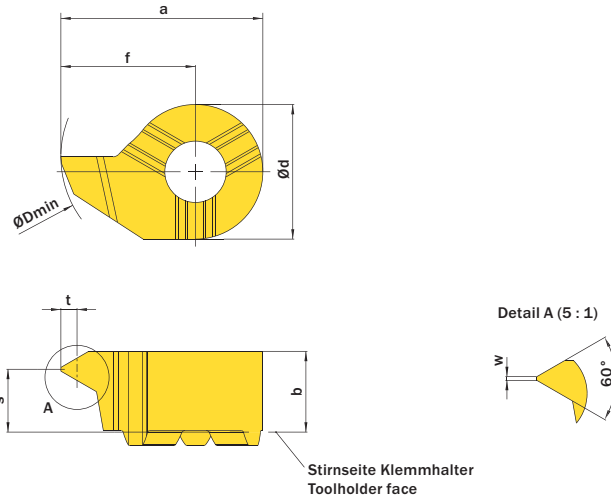


Abbildung zeigt / Drawing shows: D14.1020.01 M R

Steigung (von) Pitch (as of)	Steigung (bis) Pitch (up to)	Artikelnummer Part number	Webcode <small>www.simtek.com/webcode</small>	Unsere erste Wahl Our first choice	a	t	b	Ød	ØDmin (Min. Bohrung) ØDmin (min. bore)	f	S	w	Connectcode <small>www.simtek.com/code</small>
mm	mm			P K M N S	mm	mm	mm	mm	mm	mm	mm	mm	

Fortgesetzte Tabelle
Continued Table

Verwandte Werkzeuge finden Sie auch auf der vorhergehenden Seite!
Related items can be found on the previous page as well!

▼ ØDmin (Min. Bohrung) // ØDmin (min. bore) = 11,0 mm													
0,5	0,75	D11.0205.01 MR/L	R AJEC L ANKC	X800 X400	10,7	0,43	4,2	8,0	11,0	6,7	3,75	0,06	D11
1,0	1,25	D11.0510.01 MR/L	R ABSH L ACPA	X800 X400	10,7	0,7	4,2	8,0	11,0	6,7	3,6	0,12	D11
1,5	1,75	D11.0815.01 MR/L	R AGA9 L AC8F	X800 X400	10,7	0,98	4,2	8,0	11,0	6,7	3,2	0,18	D11 upd
2,0	2,5	D11.1020.01 MR/L	R AJ8F L AGUB	X800 X400	10,7	1,41	4,2	8,0	11,0	6,7	2,9	0,25	D11 upd
2,5	3,0	D11.1325.01 MR/L	R AFSG L AMNB	X800 X400	10,7	1,68	4,2	8,0	11,0	6,7	2,8	0,31	D11 upd
▼ ØDmin (Min. Bohrung) // ØDmin (min. bore) = 14,0 mm													
1,0	1,25	D14.0510.01 MR/L	R AAYN L AJ9C	X800 X400	13,5	0,55	5,4	9,0	14,0	9,0	4,6	0,12	D14
1,5	1,75	D14.0815.01 MR/L	R AM9F L ADYM	X800 X400	13,5	0,81	5,4	9,0	14,0	9,0	4,3	0,18	D14
2,0	2,5	D14.1020.01 MR/L	R AEQN L AA41	X800 X400	13,5	1,08	5,4	9,0	14,0	9,0	3,9	0,25	D14
2,5	3,0	D14.1325.01 MR/L	R APM1 L AEX9	X800 X400	13,5	1,35	5,4	9,0	14,0	9,0	3,55	0,31	D14
▼ ØDmin (Min. Bohrung) // ØDmin (min. bore) = 16,0 mm													
1,0	1,25	D16.0510.01 MR/L	R AFMB L ACG7	X800 X400	15,7	0,7	5,4	11,0	16,0	10,2	4,8	0,12	D16
1,5	1,75	D16.0815.01 MR/L	R AFAG L ANF1	X800 X400	15,7	0,98	5,4	11,0	16,0	10,2	4,6	0,18	D16
2,0	2,5	D16.1020.01 MR/L	R AG9J L AJDQ	X800 X400	15,7	1,41	5,4	11,0	16,0	10,2	4,35	0,25	D16
2,5	3,0	D16.1325.01 MR/L	R AKYZ L AGDW	X800 X400	15,7	1,68	5,4	11,0	16,0	10,2	4,15	0,31	D16

Bestellbeispiel // Order example: **D11.0815.01 MR X800** (R = Rechte Ausführung // Right hand version, X800 = Schneidstoff // Grade)

Bitte beachten Sie die zusätzlichen Hinweise zu den Mehrbereichswerkzeugen im Infobereich rechts oben.
Please read the additional notes mentioned in the information area on the top right corner of this page.

Gewindedrehen, Trapezgewinde, Teilprofil

Teilprofil für Trapez-Gewinde.

Threading, Trapezoidal Partial Profile

Partial profile for internal trapezoidal-thread.

Schnittwerte (Start) // Cutting parameters (start)
Anzahl Durchgänge // Number of passes 12 - 18
Empf. Zustellungsart // Recom. infeed method Flankenzustellung // Flank infeed (Seite/Page 433)
Vc Seite/Page 429

Passende Klemmhalter auf Seite // Suitable toolholders on page
155, 156, 157, 158, 159, 161, 163, 164

SP

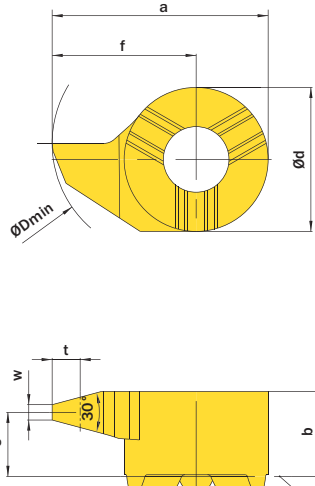
HM

R

Legende
Legend **213**

Scan
QR-Code

Oder besuchen Sie // Or Visit
www.simtek.info/cp/825



Stirnseite-Klemmhalter
Toolholder face

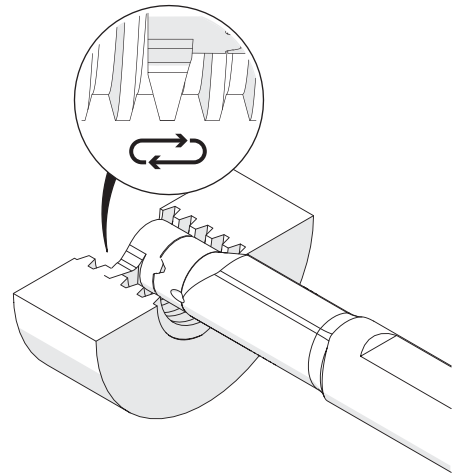


Abbildung zeigt / Drawing shows: D14.1730.01 MR

Ab Gewindegröße As of thread size	t mm	Steigung (von) Pitch (as of) mm	Artikelnummer Part number	Webcode www.simtek.com/webcode	Unsere erste Wahl Our first choice					a mm	b mm	Ød mm	ØDmin (Min. Bohrung) ØDmin (min. bore) mm	f mm	S mm	w mm	Connectcode www.simtek.com/code
					P	K	M	N	S								
▼ Ab Gewindegröße // As of thread size = 12,0																	
12,0	0,9	1,5	D09.TR15.01.09 MR/L	R AWF1	L AWHE	X800	X400		8,6	3,55	6,2	9,0	5,5	3,0	0,47		D09
12,0	1,25	2,0	D09.TR20.01.09 MR/L	R AWF0	L AWHD	X800	X400		8,6	3,55	6,2	9,0	5,5	2,85	0,6		D09
12,0	0,9	1,5	D10.TR15.01.10 MR/L	R ASBH	L ASBG	X800	X400		9,3	3,95	7,0	10,0	5,8	3,32	0,47		D10
▼ Ab Gewindegröße // As of thread size = 14,0																	
14,0	1,75	3,0	D09.TR30.01.09 MR/L	R AWFZ	L AWHC	X800	X400		8,6	3,55	6,2	9,0	5,5	2,25	0,96		D09
14,0	1,25	2,0	D10.TR20.01.10 MR/L	R ASBK	L ASBJ	X800	X400		9,3	3,7	7,0	10,0	5,8	2,91	0,6		D10
14,0	1,75	3,0	D10.TR30.01.10 MR/L	R ASBN	L ASBM	X800	X400		9,3	3,7	7,0	10,0	5,8	2,57	0,96		D10
14,0	0,9	1,5	D11.1015.01 MR/L	R AA9G	L AAQ0	X800	X400		10,7	4,3	8,0	11,0	6,7	3,7	0,47		D11
14,0	1,25	2,0	D11.1220.01 MR/L	R AF6J	L AH27	X800	X400		10,7	4,3	8,0	11,0	6,7	3,5	0,6		D11
▼ Ab Gewindegröße // As of thread size = 16,0																	
16,0	2,25	4,0	D09.TR40.01.10 MR/L	R AWFY	L AWHB	X800	X400		9,6	3,55	6,2	10,0	6,5	2,25	1,33		D09
16,0	2,25	4,0	D10.TR40.01.11 MR/L	R ASBQ	L ASBP	X800	X400		10,3	3,7	7,0	11,0	6,8	2,14	1,33		D10
16,0	1,75	3,0	D11.1730.01 MR/L	R AP1Y	L AMT5	X800	X400		10,7	4,3	8,0	11,0	6,7	3,2	0,96		D11
16,0	2,25	4,0	D11.2240.01 MR/L	R ANXG	L AFT8	X800	X400		10,7	4,0	8,0	11,0	6,7	2,6	1,33		D11
▼ Ab Gewindegröße // As of thread size = 18,0																	
18,0	1,25	2,0	D14.1220.01 MR/L	R AD11	L AFN9	X800	X400		13,5	5,3	9,0	14,0	9,0	4,3	0,6		D14
18,0	1,75	3,0	D14.1730.01 MR/L	R AMAN	L ANQF	X800	X400		13,5	5,3	9,0	14,0	9,0	4,0	0,96		D14
▼ Ab Gewindegröße // As of thread size = 20,0																	
20,0	2,25	4,0	D14.2240.01 MR/L	R AGYM	L AKD9	X800	X400		13,5	5,3	9,0	14,0	9,0	4,0	1,33		D14
20,0	1,25	2,0	D16.1220.01 MR/L	R AGNW	L AAX2	X800	X400		15,2	5,5	11,0	16,0	9,7	4,5	0,6		D16
20,0	1,75	3,0	D16.1730.01 MR/L	R AG99	L AM5S	X800	X400		15,2	5,5	11,0	16,0	9,7	4,3	0,96		D16
▼ Ab Gewindegröße // As of thread size = 22,0																	
22,0	2,75	5,0	D14.2750.01 MR/L	R AJ51	L AA01	X800	X400		13,5	5,3	9,0	14,0	9,0	3,55	1,69		D14
22,0	2,25	4,0	D16.2240.01 MR/L	R ANBP	L ACCX	X800	X400		15,2	5,5	11,0	16,0	9,7	4,0	1,33		D16
22,0	2,75	5,0	D16.2750.01 MR/L	R APG1	L ANCP	X800	X400		15,7	5,5	11,0	16,0	10,2	3,6	1,69		D16
▼ Ab Gewindegröße // As of thread size = 32,0																	
32,0	3,5	6,0	D16.3560.01 MR/L	R AEJX	L APZ5	X800	X400		15,7	5,5	11,0	16,0	10,2	3,3	1,92		D16

Bestellbeispiel // Order example: **D16.2750.01 MR X800** (R = Rechte Ausführung // Right hand version, X800 = Schneidstoff // Grade)

Gewindedrehen, BSW/BSF Vollprofil

Herstellung des vollständigen Gewindeprofils mit erforderlicher Tiefe sowie Kopf- und Fußradien.

Threading, BSW/BSF Full Profile

For a complete thread profile with correct depth, top radius and bottom radius.

Schnittwerte (Start) // Cutting parameters (start)
Anzahl Durchgänge // Number of passes 10 - 16
Empf. Zustellungsart // Recom. infeed method Flankenzustellung // Flank infeed (Seite/Page 433)
Vc Seite/Page 429

Passende Klemmhalter auf Seite // Suitable toolholders on page
156, 157, 158, 159, 161, 163, 164

SP **HM** **R** Legende Legend **213**

Scan QR-Code Oder besuchen Sie // Or Visit www.simtek.info/cp/821

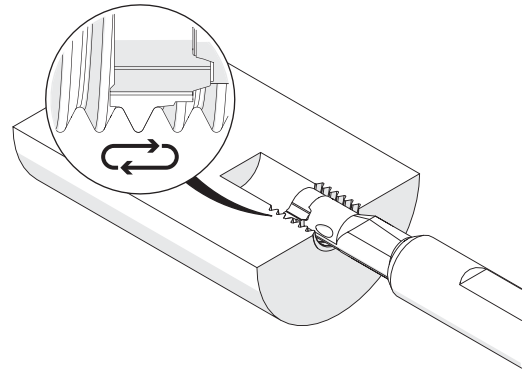
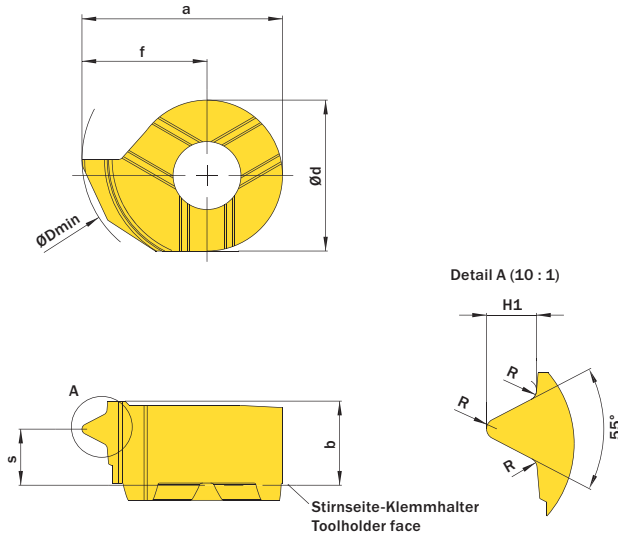


Abbildung zeigt / Drawing shows: D10.1118.14.10 M R

H1	Steigung (von) Pitch (as of)	Gang/Zoll Threads/Inch	Artikelnummer Part number	Webcode www.simtek.com/webcode	Unsere erste Wahl Our first choice					a	b	Ød	ØDmin (Min. Bohrung) ØDmin (min. bore)	f	R	S	Connectcode www.simtek.com/code
					P	K	M	N	S								
▼ ØDmin (Min. Bohrung) // ØDmin (min. bore) = 10,0 mm																	
0,85	1,337	19	D10.0813.19.10 MR/L	R AF1V	L AD9V	X800	X400		9,3	3,8	7,0	10,0	5,8	0,18	2,8		D10
1,16	1,814	14	D10.1118.14.10 MR/L	R APMJ	L ADU8	X800	X400		9,3	3,8	7,0	10,0	5,8	0,24	2,6		D10
1,48	2,309	11	D10.1423.11.10 MR/L	R AFYX	L APUK	X800	X400		9,3	3,8	7,0	10,0	5,8	0,31	2,3		D10
▼ ØDmin (Min. Bohrung) // ØDmin (min. bore) = 11,0 mm																	
0,85	1,337	19	D11.0813.19 MR/L	R AMMN	L AKQV	X800	X400		10,7	4,3	8,0	11,0	6,7	0,18	2,7		D11
1,16	1,814	14	D11.1118.14 MR/L	R AGJS	L AB2A	X800	X400		10,7	4,3	8,0	11,0	6,7	0,24	3,0		D11
▼ ØDmin (Min. Bohrung) // ØDmin (min. bore) = 14,0 mm																	
0,85	1,337	19	D14.0813.19 MR/L	R ANYF	L AGT5	X800	X400		13,5	5,4	9,0	14,0	9,0	0,18	3,8		D14
1,16	1,814	14	D14.1118.14 MR/L	R AGGU	L APH5	X800	X400		13,5	5,4	9,0	14,0	9,0	0,24	3,6		D14
▼ ØDmin (Min. Bohrung) // ØDmin (min. bore) = 16,0 mm																	
1,16	1,814	14	D16.1118.14 MR/L	R AGFF	L ABXY	X800	X400		15,7	5,4	11,0	16,0	10,2	0,24	3,9		D16
1,48	2,309	11	D16.1423.11 MR/L	R AMQC	L AKAB	X800	X400		15,7	5,4	11,0	16,0	10,2	0,31	3,5		D16

Bestellbeispiel // Order example: **D10.0813.19.10 MR X800** (R = Rechte Ausführung // Right hand version, X800 = Schneidstoff // Grade)

Gewindedrehen, ACME / STUB-ACME, Teilprofil

Teilprofil für ACME- und STUB-ACME-Gewinde.

Threading, ACME / STUB-ACME, Partial Profile

Partial profile for internal ACME- and STUB-ACME thread.

Schnittwerte (Start) // Cutting parameters (start)
Anzahl Durchgänge // Number of passes 12 - 18
Empf. Zustellungsart // Recom. infeed method Flankenzustellung // Flank infeed (Seite/Page 433)
Vc Seite/Page 429

Passende Klemmhalter auf Seite // Suitable toolholders on page
156, 157, 161, 163, 164

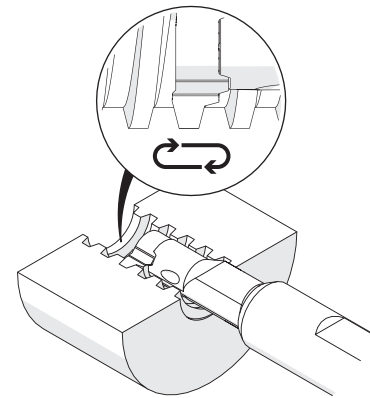
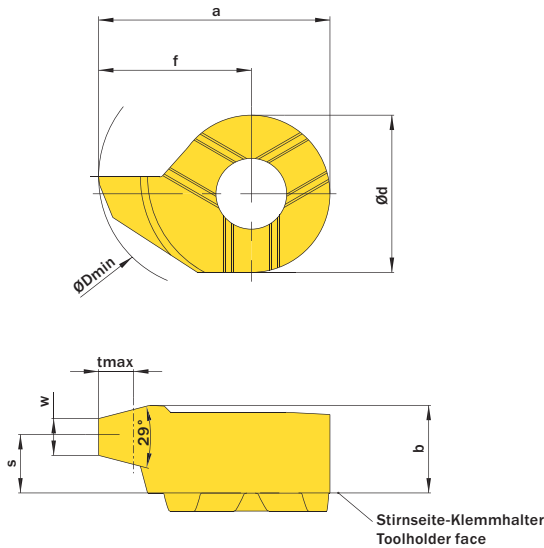
SP

HM

R

Legende
Legend **213**

Scan
QR-Code Oder besuchen Sie // Or Visit
www.simtek.info/cp/820

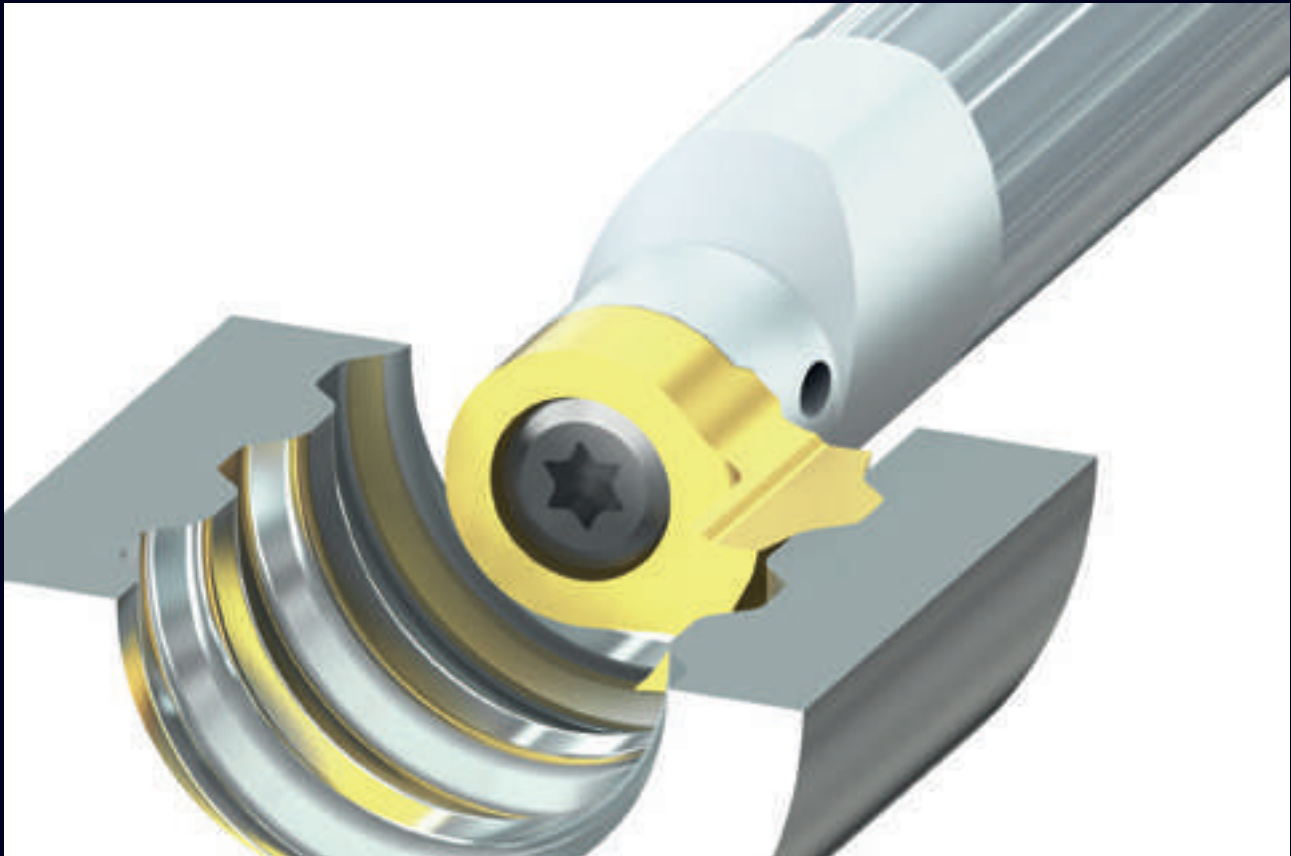


Gang/Zoll Threads/Inch	ØDmin (Min. Bohrung) ØDmin (min. bore)	Gewindetyp	Artikelnummer Part number	Webcode www.simtek.com/webcode	Unsere erste Wahl Our first choice					a	b	Ød	f	Steigung (von) Pitch (as of)	S	w	tmax	Connectcode www.simtek.com/ccode
					P	K	M	N	S									
▼ Gang/Zoll // Threads/Inch = 10																		
10	10,0	STUB-ACME	D10.SA10.01.10 MR/L	R AGDD L AFWG	X800	X400			9,3	3,9	7,0	5,8	2,54	2,9	0,94	1,19	D10	
▼ Gang/Zoll // Threads/Inch = 12																		
12	10,0	STUB-ACME	D10.SA12.01.10 MR/L	R AS1G L ATV7	X800	X400			9,3	3,9	7,0	5,8	2,117	2,95	0,82	0,92	D10	
▼ Gang/Zoll // Threads/Inch = 5																		
5	11,0	ACME	D10.AC05.01.11 MR	A3TD	X800	X400			10,3	3,7	7,0	6,8	5,08	1,9	1,75	2,79	D10	new
5	10,0	STUB-ACME	D10.SA05.01.10 MR/L	R AFAM L AE4B	X800	X400			9,3	3,7	7,0	5,8	5,08	1,95	2,01	2,04	D10	
▼ Gang/Zoll // Threads/Inch = 6																		
6	11,0	ACME	D10.AC06.01.11 MR/L	R AEAB L AJ18	X800	X400			10,3	3,9	7,0	6,8	4,233	2,3	1,43	2,63	D10	
6	10,0	STUB-ACME	D10.SA06.01.10 MR/L	R AK49 L AGC9	X800	X400			9,3	3,7	7,0	5,8	4,233	2,35	1,65	1,76	D10	
6	11,0	ACME	D11.AC06.01 MR/L	R AKTH L ATV6	X800	X400			10,7	3,95	8,0	6,7	4,233	2,5	1,43	2,39	D11	
▼ Gang/Zoll // Threads/Inch = 8																		
8	11,0	ACME	D10.AC08.01.11 MR/L	R AJCF L AHZU	X800	X400			10,3	3,9	7,0	6,8	3,175	2,65	1,04	2,1	D10	
8	10,0	STUB-ACME	D10.SA08.01.10 MR/L	R AB7E L AF6Z	X800	X400			9,3	3,72	7,0	5,8	3,175	2,3	1,21	1,41	D10	

Bestellbeispiel // Order example: **D10.AC06.01.11 MR X800** (R = Rechte Ausführung // Right hand version, X800 = Schneidstoff // Grade)

Individualwerkzeuge // Customized tools

Kundenindividuelle Werkzeuglösungen Customer-specific tooling solutions



Herstellung eines breiten kundenindividuellen Gewindes in einer engen Bohrung. simturn DX bietet dank einer großen Rohlingsauswahl in verschiedenen Größen unzählige Möglichkeiten, kundenspezifische Individualwerkzeuge für eine kosteneffiziente Bauteilfertigung herzustellen.

Manufacturing of a wide customized thread in a narrow bore. Thanks to a large selection of blanks in different sizes, simturn DX offers countless possibilities to produce customized individual tools for a cost-efficient component production.

SIMTEK Individualwerkzeuge bieten unzählige Vorteile! Neben unserem Anspruch, jeweils die qualitativ bestmögliche Werkzeuglösung für Ihre Anwendung anzubieten, ist es auch unser Bestreben Ihnen durch ein SIMTEK Individualwerkzeug den größtmöglichen wirtschaftlichen Nutzen zu liefern! Tausende, aktuell erfolgreich eingesetzte Individualwerkzeuge bestätigen dies!

SIMTEK individual tools offer countless advantages! In addition to our goal to offer the qualitatively best possible tooling solution for your application, we also aspire to provide you with the greatest possible economic benefit from a customized SIMTEK tool! Thousands of currently successfully used SIMTEK individual tools confirm this!

Kontaktieren Sie uns und lassen auch Sie sich von den Vorteilen mit SIMTEK Individualwerkzeugen überzeugen!

Contact us and convince yourself of the advantages of SIMTEK individual tools!

simturnDX
SIMTEK small part machining type DX

Gewindedrehen, NPT Vollprofil

Herstellung des vollständigen Gewindeprofils mit erforderlicher Tiefe.

Threading, NPT Full Profile

For a complete thread profile with correct depth.

Schnittwerte (Start) // Cutting parameters (start)
Anzahl Durchgänge // Number of passes 10 - 16
Empf. Zustellungsart // Recom. infeed method Flankenzustellung // Flank infeed (Seite/Page 433)
Vc Seite/Page 429

Passende Klemmhalter auf Seite // Suitable toolholders on page
156, 161, 164



SP
HM
R
 Legende Legend **213**
 Scan QR-Code Oder besuchen Sie // Or Visit www.simtek.info/cp/824

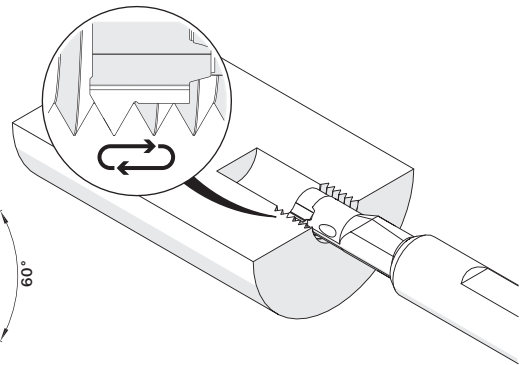
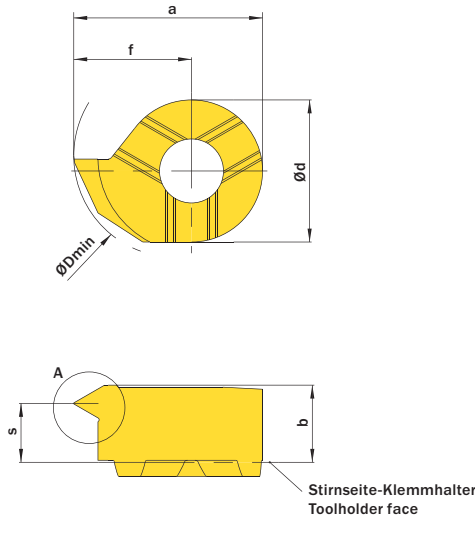


Abbildung zeigt / Drawing shows: D10.NP18.02.10 MR

Gang/Zoll Threads/Inch	ØDmin (Min. Bohrung) ØDmin (min. bore)	Artikelnummer Part number	Webcode www.simtek.com/webcode	Unsere erste Wahl Our first choice	a	b	Ød	f	H1	Steigung (von) Pitch (as of)	s	w	Connectcode www.simtek.com/code
▼ Gang/Zoll // Threads/Inch = 14													
14	10,0	D10.NP14.02.10 MR/L	R AHTH L AHKY X800 X400		9,3	3,9	7,0	5,8	1,48	1,814	2,7	0,07	D10
▼ Gang/Zoll // Threads/Inch = 18													
18	10,0	D10.NP18.02.10 MR/L	R AMWT L ACWX X800 X400		9,3	3,9	7,0	5,8	1,19	1,411	2,9	0,05	D10
▼ Gang/Zoll // Threads/Inch = 27													
27	10,0	D10.NP27.02.10 MR/L	R ABKW L ADBW X800 X400		9,3	3,8	7,0	5,8	0,8	0,941	3,2	0,04	D10

Bestellbeispiel // Order example: **D10.NP18.02.10 MR X800** (R = Rechte Ausführung // Right hand version, X800 = Schneidstoff // Grade)

Gewindedrehen, UNC/UNF Vollprofil

Herstellung des vollständigen Gewindeprofils mit erforderlicher Tiefe.

Threading, UNC/UNF Full Profile

For a complete thread profile with correct depth.

Schnittwerte (Start) // Cutting parameters (start)
Anzahl Durchgänge // Number of passes 10 - 16
Empf. Zustellungsart // Recom. infeed method Flankenzustellung // Flank infeed (Seite/Page 433)
Vc Seite/Page 429

Passende Klemmhalter auf Seite // Suitable toolholders on page
156, 158, 161, 164



Legende
Legend **213**

Scan QR-Code Oder besuchen Sie // Or Visit
www.simtek.info/cp/826

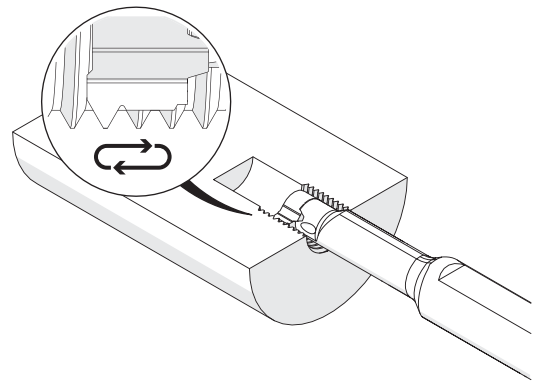
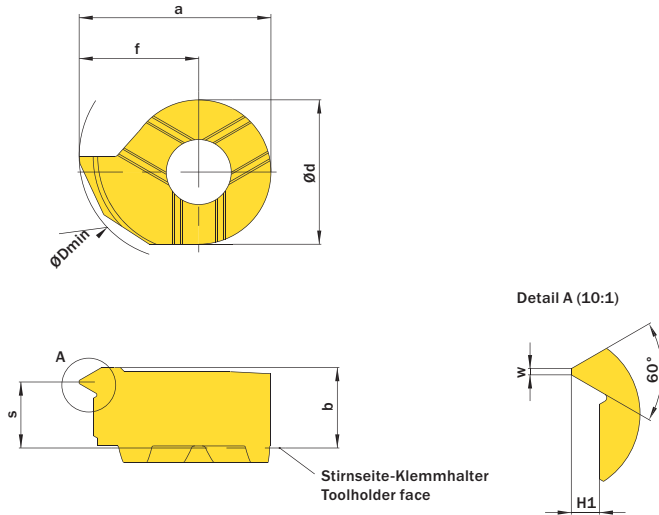


Abbildung zeigt / Drawing shows: D10.UN20.02.10 MR

Gang/Zoll Threads/Inch	ØDmin (Min. Bohrung) ØDmin (min. bore)	Artikelnummer Part number	Webcode www.simtek.com/webcode	Unsere erste Wahl Our first choice	a	b	Ød	f	H1	Steigung (von) Pitch (as of)	S	w	Connectcode www.simtek.com/code	
														P
▼ Gang/Zoll // Threads/Inch = 08														
08	10,0	D10.UN08.02.10 MR/L	R AS8Y L AS8X	X800 X400	9,3	4,0	7,0	5,8	1,72	3,17	2,5	0,39	D10	new
08	14,0	D14.UN08.02.14 M R	A2H3	X800 X400	13,5	5,35	9,0	9,0	1,72	3,17	3,75	0,39	D14	
▼ Gang/Zoll // Threads/Inch = 10														
10	14,0	D14.UN10.02.14 M R	A2H5	X800 X400	13,5	5,4	9,0	9,0	1,37	2,54	4,2	0,31	D14	
▼ Gang/Zoll // Threads/Inch = 12														
12	13,9	D14.UN12.02.14 M R	A2H7	X800 X400	13,0	5,4	9,0	8,5	1,15	2,11	4,4	0,26	D14	
▼ Gang/Zoll // Threads/Inch = 13														
13	10,0	D10.UN13.02.10 MR	A3UB	X800 X400	9,3	4,0	7,0	5,8	1,06	1,95	2,9	0,24	D10	new
▼ Gang/Zoll // Threads/Inch = 14														
14	10,0	D10.UN14.02.10 MR/L	R AMKN L AMWU	X800 X400	9,3	4,0	7,0	5,8	0,98	1,81	3,2	0,22	D10	
▼ Gang/Zoll // Threads/Inch = 16														
16	10,0	D10.UN16.02.10 MR/L	R ADTY L AG2V	X800 X400	9,3	4,0	7,0	5,8	0,86	1,59	3,1	0,19	D10	
▼ Gang/Zoll // Threads/Inch = 18														
18	10,0	D10.UN18.02.10 MR/L	R AC8W L AFWF	X800 X400	9,3	4,0	7,0	5,8	0,76	1,41	3,2	0,17	D10	
▼ Gang/Zoll // Threads/Inch = 20														
20	10,0	D10.UN20.02.10 MR/L	R AJ7T L AJ58	X800 X400	9,3	4,0	7,0	5,8	0,68	1,27	3,2	0,15	D10	
▼ Gang/Zoll // Threads/Inch = 24														
24	10,0	D10.UN24.02.10 MR/L	R AAB4 L AKGC	X800 X400	9,3	4,0	7,0	5,8	0,57	1,06	3,3	0,13	D10	
▼ Gang/Zoll // Threads/Inch = 28														
28	10,0	D10.UN28.02.10 MR/L	R AF3V L AMB5	X800 X400	9,3	4,0	7,0	5,8	0,49	0,91	3,4	0,11	D10	
▼ Gang/Zoll // Threads/Inch = 32														
32	10,0	D10.UN32.02.10 MR/L	R AB0Q L AHY0	X800 X400	9,3	4,0	7,0	5,8	0,42	0,79	3,4	0,1	D10	

Bestellbeispiel // Order example: **D10.UN28.02.10 MR X800** (R = Rechte Ausführung // Right hand version, X800 = Schneidstoff // Grade)

Axialeinstiche in Bohrungen

Geeignet ab Bohrungsdurchmesser 14,0 mm.

Face Grooving in bores

For use in bores as of minimum bore diameter 14,0 mm.

Schnittwerte (Start) // Cutting parameters (start)

f	Vc
0,02 mm/U	Seite/Page 429

Passende Klemmhalter auf Seite // Suitable toolholders on page
165, 166, 167

SP **HM** **R**

Legende Legend **213**

Scan QR-Code Oder besuchen Sie // Or Visit www.simtek.info/cp/818

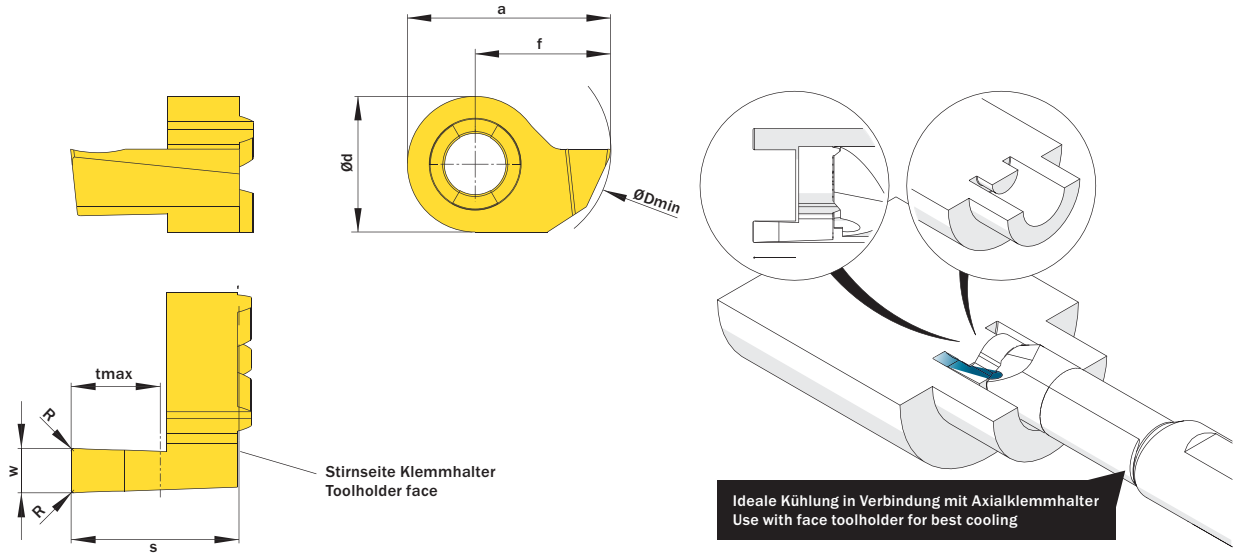


Abbildung zeigt / Drawing shows: D14.1430.62 A R

ØDmin (Min. Bohrung) ØDmin (min. bore)	w ^{+0,03}	R	tmax	Artikelnummer Part number	Webcode www.simtek.com/webcode	Unsere erste Wahl Our first choice	a	Ød	f	s	Connectcode www.simtek.com/code
mm	mm	mm	mm			P K M N S	mm	mm	mm	mm	
▼ tmax = 1,5 mm											
14,0	1,0	-	1,5	D14.1410.00 AR/L	R AB03	L AJC4 X800 X400	13,5	9,0	9,0	8,3	R D14.A.R L D14.A.L
14,0	1,168	-	1,5	D14.1411.00 AR/L	R AA1G	L AGEN X800 X400	13,5	9,0	9,0	8,3	R D14.A.R L D14.A.L inch
▼ tmax = 2,5 mm											
14,0	1,5	0,2	2,5	D14.1415.02 AR/L	R AET8	L ABZX X800 X400	13,5	9,0	9,0	8,3	R D14.A.R L D14.A.L
14,0	1,6	0,2	2,5	D14.1416.02 AR/L	R AC9S	L AGVC X800 X400	13,5	9,0	9,0	8,3	R D14.A.R L D14.A.L
14,0	1,575	0,2	2,5	D14.1416.020 AR	A4VN	X800 X400	13,5	9,0	9,0	8,3	D14.A.R new
▼ tmax = 3,0 mm											
14,0	2,0	0,2	3,0	D14.1420.02 AR/L	R AKZS	L AG57 X800 X400	13,5	9,0	9,0	8,3	R D14.A.R L D14.A.L inch
14,0	2,388	0,2	3,0	D14.1424.02 AR/L	R AF82	L AHNH X800 X400	13,5	9,0	9,0	8,3	R D14.A.R L D14.A.L inch
14,0	2,5	0,2	3,0	D14.1425.02 AR/L	R AMKF	L AJN5 X800 X400	13,5	9,0	9,0	8,3	R D14.A.R L D14.A.L
14,0	3,0	0,2	3,0	D14.1430.02 AR/L	R ABPP	L AMDG X800 X400	13,5	9,0	9,0	8,3	R D14.A.R L D14.A.L
14,0	3,175	0,2	3,0	D14.1432.02 AR/L	R AHGE	L AMA5 X800 X400	13,5	9,0	9,0	8,3	R D14.A.R L D14.A.L inch
▼ tmax = 5,0 mm											
14,0	2,0	0,2	5,0	D14.1420.52 AR/L	R AGV5	L AATA X800 X400	13,5	9,0	9,0	10,3	R D14.A.R L D14.A.L
14,0	2,388	0,2	5,0	D14.1424.52 AR/L	R AF3H	L AMMD X800 X400	13,5	9,0	9,0	10,3	R D14.A.R L D14.A.L inch
14,0	2,5	0,2	5,0	D14.1425.52 AR/L	R ACQN	L AGFZ X800 X400	13,5	9,0	9,0	10,3	R D14.A.R L D14.A.L
14,0	3,0	0,2	5,0	D14.1430.52 AR/L	R AKV7	L AJKK X800 X400	13,5	9,0	9,0	10,3	R D14.A.R L D14.A.L
14,0	3,175	0,2	5,0	D14.1432.52 AR/L	R AGHH	L ANZK X800 X400	13,5	9,0	9,0	10,3	R D14.A.R L D14.A.L inch
▼ tmax = 6,0 mm											
14,0	3,0	0,2	6,0	D14.1430.62 AR	AGU2	X800 X400	13,5	9,0	9,0	11,3	D14.A.R
▼ tmax = 10,0 mm											
18,0	3,0	0,2	10,0	D18.1830.10.02 AR/L	R AGNP	L AVST X800 X400	16,5	11,0	11,0	15,8	R D18.18.A.R L D18.18.A.L
18,0	4,0	0,2	10,0	D18.1840.10.02 AR/L	R AVJW	L AVSU X800 X400	17,0	11,0	11,5	15,8	R D18.18.A.R L D18.18.A.L

Bestellbeispiel // Order example: **D14.1430.62 AR X800** (R = Rechte Ausführung // Right hand version, X800 = Schneidstoff // Grade)

simturn AX
simturn DX
simturn PX
simturn H2
simturn K2
simturn C4
simturn GX
simturn E3
simturn E12
simturn FX
simturn Decolletage
simturn OA
Index

Axialeinstiche in Zapfen

Geeignet ab Bohrungsdurchmesser 12,0 mm.

Face Grooving on Pivots

For use in bores as of minimum bore diameter 12,0 mm.

Schnittwerte (Start) // Cutting parameters (start)

f	Vc
0,02 mm/U	Seite/Page 429

Passende Klemhalter auf Seite // Suitable toolholders on page
165, 166, 167



SP
HM
R

Legende
Legend 213

Scan
QR-Code

Oder besuchen Sie // Or Visit
www.simtek.info/cp/832

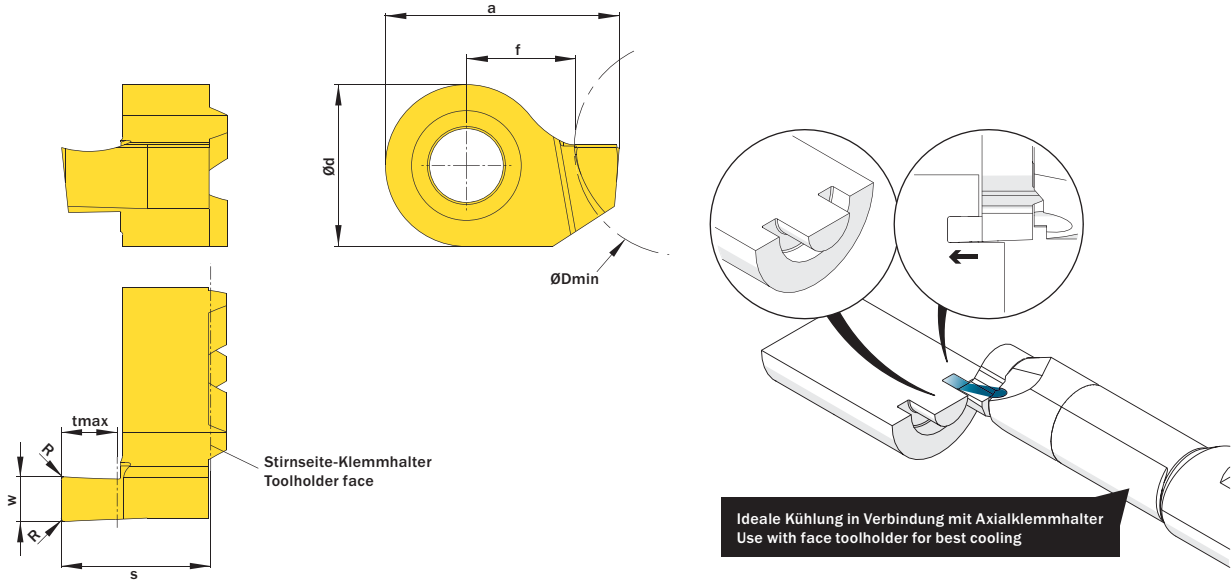


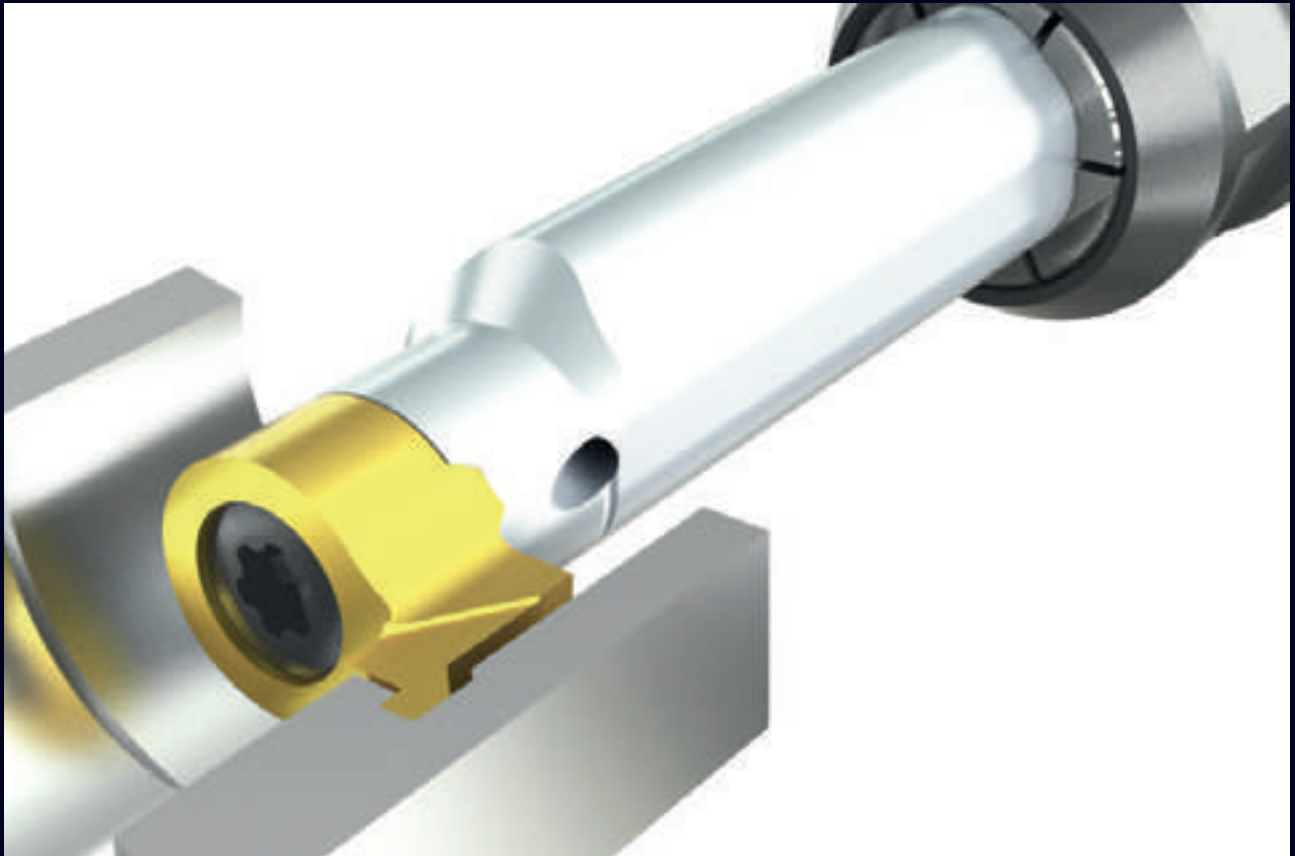
Abbildung zeigt / Drawing shows: D14.1225.02 AR

ØDmin (Min. Bohrung) ØDmin (min. bore)	w ^{+0,03}	R	tmax	Artikelnummer Part number	Webcode www.simtek.com/webcode	Unsere erste Wahl Our first choice	a	Ød	f	S	Connectcode www.simtek.com/code
mm	mm	mm	mm			P K M N S	mm	mm	mm	mm	
▼ tmax = 1,5 mm											
12,0	1,0	-	1,5	D14.1210.00 AR/L	R ABWS	L AJFU X800 X400	11,5	9,0	6,0	8,3	R D14.A.R L D14.A.L
12,0	1,168	-	1,5	D14.1211.00 AR/L	R AN2V	L AK7A X800 X400	11,67	9,0	6,0	8,3	R D14.A.R L D14.A.L inch
▼ tmax = 2,5 mm											
12,0	1,5	0,2	2,5	D14.1215.02 AR/L	R APSE	L AAPS X800 X400	12,0	9,0	6,0	8,3	R D14.A.R L D14.A.L
12,0	1,6	0,2	2,5	D14.1216.02 AR/L	R ANAD	L AMU8 X800 X400	12,1	9,0	6,0	8,3	R D14.A.R L D14.A.L
▼ tmax = 3,0 mm											
12,0	1,981	0,2	3,0	D14.1219.02 AR/L	R A1AY	L A1AX X800 X400	12,48	9,0	6,0	8,3	R D14.A.R L D14.A.L inch
12,0	2,0	0,2	3,0	D14.1220.02 AR/L	R AC8D	L AE18 X800 X400	12,5	9,0	6,0	8,3	R D14.A.R L D14.A.L
12,0	2,388	0,2	3,0	D14.1224.02 AR/L	R AKEX	L AFYK X800 X400	12,9	9,0	6,0	8,3	R D14.A.R L D14.A.L inch
12,0	2,5	0,2	3,0	D14.1225.02 AR/L	R AGWW	L AEK9 X800 X400	13,0	9,0	6,0	8,3	R D14.A.R L D14.A.L
12,0	3,0	0,2	3,0	D14.1230.02 AR/L	R AE7M	L AMQB X800 X400	13,5	9,0	6,0	8,3	R D14.A.R L D14.A.L
12,0	3,175	0,2	3,0	D14.1232.02 AR/L	R AEWC	L AJFT X800 X400	13,68	9,0	6,0	8,3	R D14.A.R L D14.A.L inch
▼ tmax = 5,0 mm											
12,0	2,0	0,2	5,0	D14.1220.52 AR/L	R ADJN	L AMVV X800 X400	12,5	9,0	6,0	10,3	R D14.A.R L D14.A.L
12,0	2,388	0,2	5,0	D14.1224.52 AR/L	R AGNN	L ADHM X800 X400	12,9	9,0	6,0	10,3	R D14.A.R L D14.A.L inch
12,0	2,5	0,2	5,0	D14.1225.52 AR/L	R AF2H	L AHXS X800 X400	13,0	9,0	6,0	10,3	R D14.A.R L D14.A.L
12,0	3,0	0,2	5,0	D14.1230.52 AR/L	R AKFF	L AP2M X800 X400	13,5	9,0	6,0	10,3	R D14.A.R L D14.A.L
12,0	3,175	0,2	5,0	D14.1232.52 AR/L	R AMPY	L AN1Y X800 X400	13,68	9,0	6,0	10,3	R D14.A.R L D14.A.L inch
▼ tmax = 6,0 mm											
12,0	3,0	0,2	6,0	D14.1230.62 AR		AAKH X800 X400	13,5	9,0	6,0	11,3	D14.A.R
▼ tmax = 10,0 mm											
16,0	3,0	0,2	10,0	D18.1630.10.02 A R/L	R AT1G	L AVSW X800 X400	16,5	11,0	8,0	15,8	R D18.16.A.R L D18.16.A.L
16,0	4,0	0,2	10,0	D18.1640.10.02 A R/L	R AT1H	L AVSV X800 X400	17,5	11,0	8,0	15,8	R D18.16.A.R L D18.16.A.L

Bestellbeispiel // Order example: **D14.1215.02 AR X800** (R = Rechte Ausführung // Right hand version, X800 = Schneidstoff // Grade)

Individualwerkzeuge // Customized tools

Kundenindividuelle Werkzeuglösungen Customer-specific tooling solutions



Axialeinstich in einer engen Bohrung mit an Störkontur angepasstem simturn DX - Schneidwerkzeug. Die präzisionsgeschliffenen simturn DX-Schneidplatten sind in 15 verschiedenen Größen für nahezu jede Anwendung in Bohrungen zwischen \varnothing 7,0 mm und ca. 24,0 mm verfügbar.

Axial groove in a narrow bore with simturn DX cutting tool, perfectly adapted to the interfering contour. The precision-ground simturn DX inserts are available in 15 different sizes for almost every application in bores between \varnothing 7.0 mm and approx. 24.0 mm.

SIMTEK Individualwerkzeuge bieten unzählige Vorteile! Neben unserem Anspruch, jeweils die qualitativ bestmögliche Werkzeuglösung für Ihre Anwendung anzubieten, ist es auch unser Bestreben Ihnen durch ein SIMTEK Individualwerkzeug den größtmöglichen wirtschaftlichen Nutzen zu liefern! Tausende, aktuell erfolgreich eingesetzte Individualwerkzeuge bestätigen dies!

SIMTEK individual tools offer countless advantages! In addition to our goal to offer the qualitatively best possible tooling solution for your application, we also aspire to provide you with the greatest possible economic benefit from a customized SIMTEK tool! Thousands of currently successfully used SIMTEK individual tools confirm this!

Kontaktieren Sie uns und lassen auch Sie sich von den Vorteilen mit SIMTEK Individualwerkzeugen überzeugen!

Contact us and convince yourself of the advantages of SIMTEK individual tools!

simturnDX
SIMTEK small part machining type DX

Axialeinstiche in Bohrungen, Vollradius

Geeignet ab Bohrungsdurchmesser 14,0 mm.

Face Grooving in bores, Full Radius

For use in bores as of minimum bore diameter 14,0 mm.

Schnittwerte (Start) // Cutting parameters (start)

f	Vc
0,02 mm/U	Seite/Page 429

Passende Klemhalter auf Seite // Suitable toolholders on page
165, 166, 167



Legende
Legend **213**



Oder besuchen Sie // Or Visit
www.simtek.info/cp/819

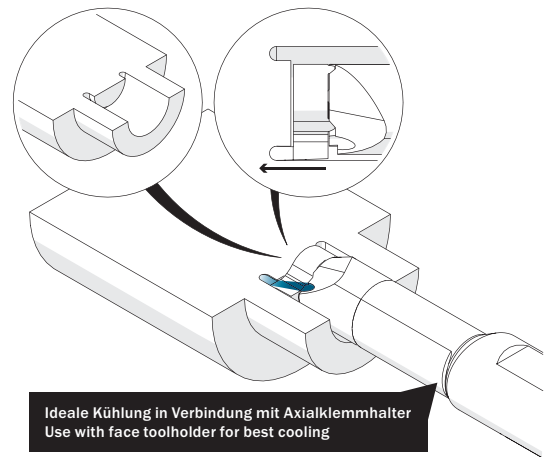
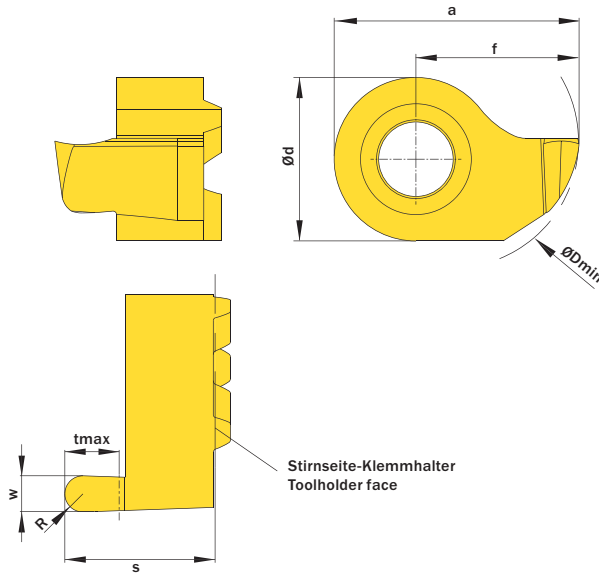


Abbildung zeigt / Drawing shows: D14.1420.10 AR

ØDmin (Min. Bohrung) ØDmin (min. bore)	w ^{+0,03}	R	Artikelnummer Part number	Webcode www.simtek.com/webcode	Unsere erste Wahl Our first choice	a	Ød	f	S	tmax	Connectcode www.simtek.com/code
mm	mm	mm			P K M N S	mm	mm	mm	mm	mm	
▼ tmax = 1,5 mm											
14,0	1,0	0,5	D14.1410.05 AR/L	R AEG0 L ACGA	X800 X400	13,5	9,0	9,0	8,3	1,5	R D14.A.R L D14.A.L
14,0	1,168	0,58	D14.1412.058 AV R	A4VQ	X800 X400	13,5	9,0	9,0	10,3	1,5	D14.A.R new inch
▼ tmax = 2,5 mm											
14,0	1,5	0,75	D14.1415.07 AR/L	R A1GH L A1GG	X800 X400	13,5	9,0	9,0	8,3	2,5	R D14.A.R L D14.A.L
14,0	1,6	0,8	D14.1416.08 AR/L	R ABNN L AFEQ	X800 X400	13,5	9,0	9,0	8,3	2,5	R D14.A.R L D14.A.L
▼ tmax = 3,0 mm											
14,0	2,0	1,0	D14.1420.10 AR/L	R APW0 L AHNX	X800 X400	13,5	9,0	9,0	8,3	3,0	R D14.A.R L D14.A.L
14,0	2,5	1,25	D14.1425.12 AR/L	R ANJW L ADX1	X800 X400	13,5	9,0	9,0	8,3	3,0	R D14.A.R L D14.A.L
14,0	3,0	1,5	D14.1430.15 AR/L	R AP37 L ABES	X800 X400	13,5	9,0	9,0	8,3	3,0	R D14.A.R L D14.A.L
▼ tmax = 5,0 mm											
14,0	2,0	1,0	D14.1420.50 AV R/L	R AWE5 L AWE4	X800 X400	13,5	9,0	9,0	10,3	5,0	R D14.A.R L D14.A.L
14,0	2,5	1,25	D14.1425.50 AV R/L	R AWE7 L AWE6	X800 X400	13,5	9,0	9,0	10,3	5,0	R D14.A.R L D14.A.L
14,0	3,0	1,5	D14.1430.50 AV R/L	R AWE9 L AWE8	X800 X400	13,5	9,0	9,0	10,3	5,0	R D14.A.R L D14.A.L

Bestellbeispiel // Order example: **D14.1420.10 AR X800** (R = Rechte Ausführung // Right hand version, X800 = Schneidstoff // Grade)

Axialeinstiche in Zapfen, Vollradius

Geeignet ab Bohrungsdurchmesser 12,0 mm.

Face Grooving on Pivots, Full Radius

For use in bores as of minimum bore diameter 12,0 mm.

Schnittwerte (Start) // Cutting parameters (start)

f	Vc
0,02 mm/U	Seite/Page 429

Passende Klemmhalter auf Seite // Suitable toolholders on page
165, 166, 167

SP

HM

R

Legende
Legend **213**

Scan
QR-Code

Oder besuchen Sie // Or Visit
www.simtek.info/cp/964

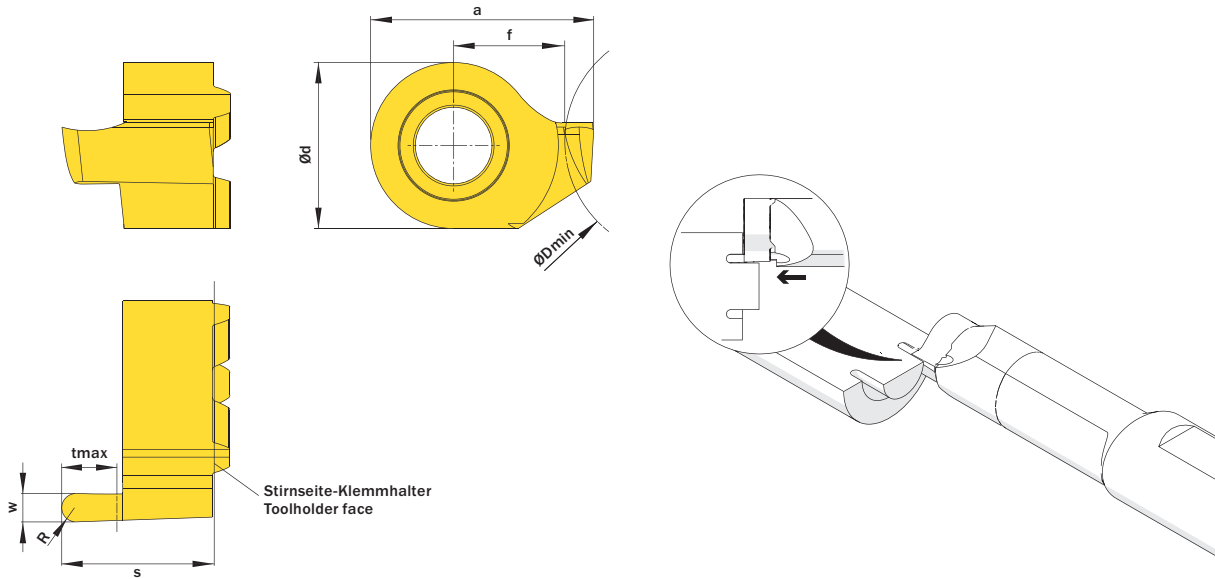


Abbildung zeigt / Drawing shows: D14.1216.08 AR

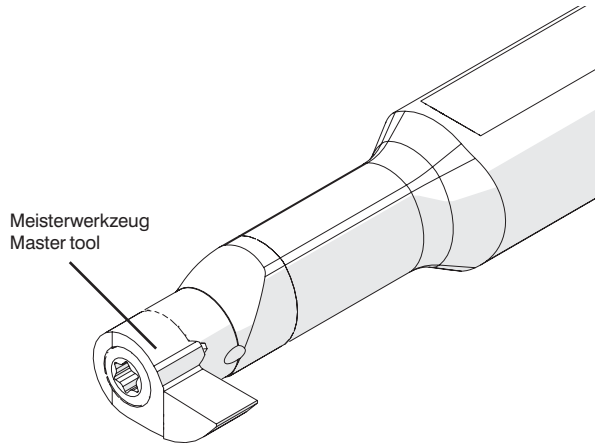
ØDmin (Min. Bohrung) ØDmin (min. bore)	w ^{+0,03}	R	Artikelnummer Part number	Webcode www.simtek.com/webcode	Unsere erste Wahl Our first choice	a	Ød	f	S	tmax	Connectcode www.simtek.com/ccode
mm	mm	mm			P K M N S	mm	mm	mm	mm	mm	
▼ tmax = 1,5 mm											
12,0	1,0	0,5	D14.1210.05 AR/L	R AU6C L AU6B	X800 X400	11,5	9,0	6,0	8,3	1,5	R D14.A.R L D14.A.L
▼ tmax = 2,5 mm											
12,0	1,5	0,75	D14.1215.07 AR/L	R A08G L A08F	X800 X400	12,0	9,0	6,0	8,3	2,5	R D14.A.R L D14.A.L
12,0	1,6	0,8	D14.1216.08 AR/L	R AU6E L AU6D	X800 X400	12,1	9,0	6,0	8,3	2,5	R D14.A.R L D14.A.L
▼ tmax = 3,0 mm											
12,0	2,0	1,0	D14.1220.10 AR/L	R AU6G L AU6F	X800 X400	12,5	9,0	6,0	8,3	3,0	R D14.A.R L D14.A.L
12,0	2,5	1,25	D14.1225.12 AR/L	R AU6J L AU6H	X800 X400	13,0	9,0	6,0	8,3	3,0	R D14.A.R L D14.A.L
12,0	3,0	1,5	D14.1230.15 AR/L	R AU6M L AU6K	X800 X400	13,5	9,0	6,0	8,3	3,0	R D14.A.R L D14.A.L
▼ tmax = 5,0 mm											
12,0	2,0	1,0	D14.1220.50 AV R/L	R AWEZ L AWEY	X800 X400	12,5	9,0	6,0	10,3	5,0	R D14.A.R L D14.A.L
12,0	2,5	1,25	D14.1225.50 AV R/L	R AWE1 L AWE0	X800 X400	13,0	9,0	6,0	10,3	5,0	R D14.A.R L D14.A.L
12,0	3,0	1,5	D14.1230.50 AV R/L	R AWE3 L AWE2	X800 X400	13,5	9,0	6,0	10,3	5,0	R D14.A.R L D14.A.L

Bestellbeispiel // Order example: **D14.1220.50 AV R X800** (R = Rechte Ausführung // Right hand version, X800 = Schneidstoff // Grade)

Info

Hinweisliste
Additional Information

MASTER



Zur korrekten Ausrichtung des Klemmhalters in Hydrodehnspannfuttern (o.ä.), bestellen Sie bitte die folgenden Meisterwerkzeuge, die im eingebauten Zustand ein korrektes und sicheres Ausrichten ermöglichen.

Please use the following Master tools, for adjusting and positioning the toolholder in hydraulic expansion chucks. These Master tools provide an easy and secure way.

Meisterwerkzeug Master tool	Webcode	Für Klemmhalter For toolholder
D07.MASTER GF25	A25K	D07...
D09.MASTER GF25	A25M	D09...
D10.MASTER R GF25	ATWD	D10...
D11.MASTER GF25	A25N	D11...
D14.MASTER R GF25	ATWC	D14...
D16.MASTER GF25	A25P	D16...
D18.MASTER GF25	A25Q	D18...

T01

Bei den simturn Teilprofil-Gewindeschneidplatten für metrische ISO-Gewinde handelt es sich um Mehrbereichswerkzeuge, d.h. dass mit einem Werkzeug unterschiedliche Steigungen gefertigt werden können.

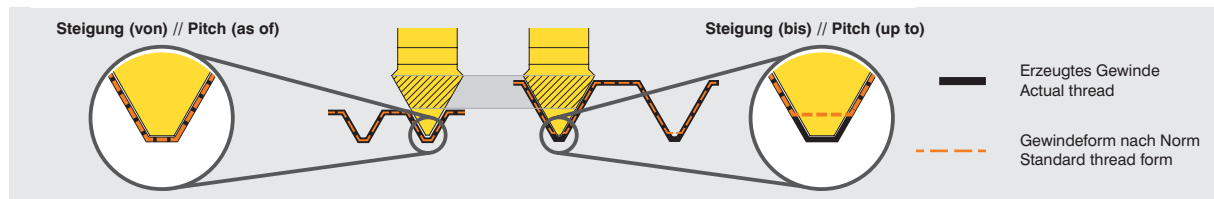
Das Schneidwerkzeug ist dabei immer auf die angegebene „Steigung (von)“ ausgelegt, wodurch ein normgerechtes Gewinde beim Fertigen dieser Steigung entsteht.

Die ebenfalls angegebene „Steigung (bis)“ kann mit diesem Werkzeug ebenfalls gefertigt werden. Es entsteht hierbei jedoch ein - gegenüber der Norm - geringfügig tieferes Gewinde. Die geringfügig höhere Gewindetiefe ist i.d.R. akzeptabel, es muss jedoch immer der Einzelfall beurteilt werden.

The simturn threading inserts with partial profile for metric ISO-threads are multi-purpose tools. This means that each insert is offering the possibility to machine different pitches.

The insert is always designed to meet the pitch given as „Pitch (as of)“: Machining this pitch will result in a standard conform thread form.



The given „Pitch (up to)“ can be machined too with this insert at the expense of standard conformity: The resulting thread will be slightly deeper than the standard. The deeper thread is usually acceptable, but the application and use needs to be evaluated.



Beispiel // Example

Legende

Legend

- SP**
CBN Schneidwerkzeug aus CBN // CBN insert // Outils coupants en CBN // Insetto CBN // Insetto CBN // CBN kesici uç
- SP**
HM Schneidwerkzeug aus Hartmetall // Carbide insert // Outils coupants en carbure de tungstène // Insetto in metallo duro
Insetto de carburo // Karbür kesici uç
- TW**
HM Trägerwerkzeug aus Hartmetall // Carbide toolholder // Porte-outils en carbure // Porta inserto in metallo duro
Porta-herramientas de carburo // Karbür tutucu
- TW**
ST Trägerwerkzeug aus Stahl // Steel toolholder // Porte-outils en acier // Porta inserto in acciaio
Porta-herramientas de acero // Çelik tutucu
- ME**
ME ME-Spannprinzip // ME-clamping system // ME-système de fixation // Sistema di fissaggio - ME
Principio de sujeción ME // ME sıkma sistemli
- R** Rechts wie gezeichnet // Right hand version shown, left hand version inversely // A droite comme présenté // In figura utensile destro
Modelo derecho // Sağ model
-  Innere Kühlmittelzufuhr // Through coolant // Refroidissement interne // Lubrificazione interna
Con refrigeración interna // İçten soğutmalı
-  Schwingungsgedämpft // Anti-vibration // Anti vibration // Antivibrante // Anti-vibración // Anti vibrasyon

Index

simturn DX Produktverzeichnis
simturn DX Product List

Artikelnr. // Part Nr.	S/P	Artikelnr. // Part Nr.	S/P	Artikelnr. // Part Nr.	S/P	Artikelnr. // Part Nr.	S/P	Artikelnr. // Part Nr.	S/P
D07.0.500.21 HM	153	D08.0070.00 ZL	177	D09.0.500.30 HM	155	D09.0917.01.09 MR	199	D10.0090.00.10 GR	179
D07.0.500.21 ST	164	D08.0070.00 ZR	177	D09.0.500.42 HM	155	D09.0917.02.09 ML	197	D10.0100.00.10 GL	179
D07.0.500.30 HM	153	D08.0078.00 GL	177	D09.0.625.14 ST	164	D09.0917.02.09 MR	197	D10.0100.00.10 GR	179
D07.0.500.42 HM	153	D08.0078.00 GR	177	D09.0004.08.09 VL	192	D09.1020.01.09 ML	199	D10.0100.00.11 GL	180
D07.0.625.12 ST	164	D08.0078.02 NL	189	D09.0004.08.09 VR	192	D09.1020.01.09 MR	199	D10.0100.00.11 GR	180
D07.0012.21 HM	153	D08.0078.02 NR	189	D09.0005.10.09 VL	192	D09.1020.02.09 ML	197	D10.0100.00.12 GL	182
D07.0012.21 ST	164	D08.0080.00 ZL	177	D09.0005.10.09 VR	192	D09.1020.02.09 MR	197	D10.0100.00.12 GR	182
D07.0012.30 HM	153	D08.0080.00 ZR	177	D09.0006.12.09 VL	192	D09.1325.01.09 ML	199	D10.0110.00.10 GL	179
D07.0012.42 HM	153	D08.0090.00 ZL	177	D09.0006.12.09 VR	192	D09.1325.01.09 MR	199	D10.0110.00.10 GR	179
D07.0016.12 ST	164	D08.0090.00 ZR	177	D09.0009.18.09 VL	192	D09.1325.02.09 ML	197	D10.0130.00.10 GL	179
D07.0100.00.07 GL	176	D08.0100.00 GL	177	D09.0009.18.09 VR	192	D09.1325.02.09 MR	197	D10.0130.00.10 GR	179
D07.0100.00.07 GR	176	D08.0100.00 GR	177	D09.0010.20.09 VL	192	D09.1630.01.09 ML	199	D10.0150.00.10 GL	179
D07.0100.00.08 GL	176	D08.0110.00 GL	177	D09.0010.20.09 VR	192	D09.1630.01.09 MR	199	D10.0150.00.10 GR	179
D07.0100.00.08 GR	176	D08.0110.00 GR	177	D09.0012.22 HM	155	D09.1630.02.09 ML	197	D10.0150.00.11 GL	180
D07.0150.00.07 GL	176	D08.0117.02 NL	189	D09.0012.30 HM	155	D09.1630.02.09 MR	197	D10.0150.00.11 GR	180
D07.0150.00.07 GR	176	D08.0117.02 NR	189	D09.0012.42 HM	155	D09.1855.02.09 YL	168	D10.0150.00.12 GL	182
D07.0150.00.08 GL	176	D08.0130.00 GL	177	D09.0012.56 HM	155	D09.1855.02.09 YR	168	D10.0150.00.12 GR	182
D07.0150.00.08 GR	176	D08.0130.00 GR	177	D09.0016.14 ST	164	D09.2055.02.09 YL	168	D10.0150.02.10 NL	189
D07.0150.02.08 NL	189	D08.0150.00 GL	177	D09.0055.02.09 YEL	169	D09.2055.02.09 YR	168	D10.0150.02.10 NR	189
D07.0150.02.08 NR	189	D08.0150.00 GR	177	D09.0055.02.09 YER	169	D09.3055.02.09 YL	174	D10.0150.02.11 NL	190
D07.1841.01 YL	168	D08.0150.02 NL	189	D09.0070.00.09 GL	178	D09.3055.02.09 YR	174	D10.0150.02.11 GR	190
D07.1841.01 YR	168	D08.0150.02 NR	189	D09.0070.00.09 GR	178	D09.3065.02.10 YL	174	D10.0150.02.12 NL	190
D07.1841.02 YL	168	D08.0157.00 GL	177	D09.0080.00.09 GL	178	D09.3065.02.10 YR	174	D10.0150.02.12 NR	190
D07.1841.02 YR	168	D08.0157.00 GR	177	D09.0080.00.09 GR	178	D09.3255.02.09 YL	171	D10.0160.00.10 GL	179
D07.3246.02 YR	171	D08.0157.02 NL	189	D09.0090.00.09 GL	178	D09.4545.02.09 YL	173	D10.0160.00.10 GR	179
D07.4545.02.07 FL	173	D08.0157.02 NR	189	D09.0090.00.09 GR	178	D09.4545.02.09 FR	173	D10.0198.02.10 NR	189
D07.4545.02.07 FR	173	D08.0160.00 GL	177	D09.0100.00.09 GL	178	D09.4755.02.09 YL	172	D10.0200.00.10 GL	179
D07.4746.02 YL	172	D08.0160.00 GR	177	D09.0100.00.09 GR	178	D09.4755.02.09 YR	172	D10.0200.00.10 GR	179
D07.4746.02 YR	172	D08.0198.00 GL	177	D09.0110.00.09 GL	178	D09.TR15.01.09 ML	201	D10.0200.00.11 GL	180
D07.A06.20 HM	162	D08.0198.00 GR	177	D09.0110.00.09 GR	178	D09.TR15.01.09 MR	201	D10.0200.00.11 GR	180
D07.A06.30 HM	162	D08.0198.02 NL	189	D09.0130.00.09 GL	178	D09.TR20.01.09 ML	201	D10.0200.00.12 GL	182
D07.A06.40 HM	162	D08.0198.02 NR	189	D09.0130.00.09 GR	178	D09.TR20.01.09 MR	201	D10.0200.00.12 GR	182
D07.A06.50 HM	162	D08.0200.00 GL	177	D09.0150.00.09 GL	178	D09.TR30.01.09 ML	201	D10.0200.02.10 NL	189
D07.A06.60 HM	162	D08.0200.00 GR	177	D09.0150.00.09 GR	178	D09.TR30.01.09 MR	201	D10.0200.02.10 NR	189
D07.MT05.01.07 ML	199	D08.0200.02 NL	189	D09.0150.02.09 NL	189	D09.TR40.01.10 ML	201	D10.0200.02.11 NL	190
D07.MT05.01.07 MR	199	D08.0200.02 NR	189	D09.0150.02.09 NR	189	D09.TR40.01.10 MR	201	D10.0200.02.11 GR	190
D07.MT10.01.07 ML	199	D08.0205.01 ML	199	D09.0150.02.10 NL	189	D10.0.500.22 HM	156	D10.0200.02.12 NL	190
D07.MT10.01.07 MR	199	D08.0205.01 MR	199	D09.0150.02.10 NR	189	D10.0.500.32 HM	156	D10.0200.02.12 NR	190
D07.MT15.01.07 ML	199	D08.0510.01 ML	199	D09.0160.00.09 GL	178	D10.0.500.48 HM	156	D10.0205.01.10 ML	199
D07.MT15.01.07 MR	199	D08.0510.01 MR	199	D09.0160.00.09 GR	178	D10.0.500.64 HM	156	D10.0205.01.10 MR	199
D08.0.500.12 ST	163	D08.0810.00 PL	196	D09.0200.00.09 GL	178	D10.0.625.16 ST	164	D10.0205.02.10 ML	197
D08.0.500.21 HM	154	D08.0810.00 PR	196	D09.0200.00.09 GR	178	D10.0.625.24 ST	164	D10.0205.02.10 MR	197
D08.0.500.30 HM	154	D08.0815.01 ML	199	D09.0200.02.09 NL	189	D10.0.750.24.087 ME	161	D10.0238.00.10 GL	179
D08.0.500.42 HM	154	D08.0815.01 MR	199	D09.0200.02.09 NR	189	D10.0004.08.10 VL	193	D10.0238.00.10 GR	179
D08.0.500.50 HM	154	D08.1846.005 YL	168	D09.0200.02.10 NL	189	D10.0004.08.10 VR	193	D10.0238.00.11 GL	180
D08.0.625.12 ST	163	D08.1846.005 YR	168	D09.0200.02.10 NR	189	D10.0005.10.10 VR	193	D10.0238.00.11 GR	180
D08.0004.08 VL	192	D08.1846.02 YL	168	D09.0205.01.09 ML	199	D10.0006.12.10 VL	193	D10.0250.00.10 GL	179
D08.0004.08 VR	192	D08.1846.02 YR	168	D09.0205.01.09 MR	199	D10.0006.12.10 VR	193	D10.0250.00.10 GR	179
D08.0006.12 VL	192	D08.1846.02 YU L	170	D09.0205.02.09 ML	197	D10.0009.18.10 VL	193	D10.0250.00.11 GL	180
D08.0006.12 VR	192	D08.1846.02 YU R	170	D09.0205.02.09 MR	197	D10.0009.18.10 VR	193	D10.0250.00.11 GR	180
D08.0008.157 VL	192	D08.2046.02 YL	168	D09.0250.00.09 GL	178	D10.0010.20.10 VL	193	D10.0250.00.11 GL	180
D08.0008.157 VR	192	D08.2046.02 YR	168	D09.0250.00.09 GR	178	D10.0010.20.10 VR	193	D10.0300.00.10 GR	179
D08.0008.16 VL	192	D08.2555.02 YL	171	D09.0300.00.09 GL	178	D10.0012.24 HM	156	D10.0300.00.11 GL	180
D08.0008.16 VR	192	D08.2555.02 YR	171	D09.0300.00.09 GR	178	D10.0012.32 HM	156	D10.0300.00.11 GR	180
D08.0009.18 VL	192	D08.3046.02 YL	174	D09.0500.56 HM	155	D10.0012.48 HM	156	D10.0318.00.10 GL	179
D08.0009.18 VR	192	D08.3046.02 YR	174	D09.0510.01.09 ML	199	D10.0012.64 HM	156	D10.0318.00.10 GR	179
D08.0010.20 VL	192	D08.3246.04 YR	171	D09.0510.01.09 MR	199	D10.0016.16 ST	164	D10.0318.00.11 GL	180
D08.0010.20 VR	192	D08.4545.02 FL	173	D09.0510.02.09 ML	197	D10.0016.24 ST	164	D10.0318.00.11 GR	180
D08.0012.21 HM	154	D08.4545.02 FR	173	D09.0510.02.09 MR	197	D10.0020.24.087 ME	161	D10.0510.01.10 ML	199
D08.0012.21 ST	163	D08.4746.01 YL	172	D09.0810.00.09 PL	196	D10.0056.02.10 YEL	169	D10.0510.01.10 MR	199
D08.0012.30 HM	154	D08.4746.01 YR	172	D09.0810.00.09 PR	196	D10.0056.02.10 YER	169	D10.0510.02.10 ML	197
D08.0012.42 HM	154	D08.4746.02 YL	172	D09.0815.01.09 ML	199	D10.0070.00.10 GL	179	D10.0510.02.10 MR	197
D08.0012.50 HM	154	D08.4746.02 YR	172	D09.0815.01.09 MR	199	D10.0070.00.10 GR	179	D10.0810.00.10 PL	196
D08.0016.12 ST	163	D08.4746.04 YL	172	D09.0815.02.09 ML	197	D10.0080.00.10 GL	179	D10.0810.00.10 PR	196
D08.0046.02.08 YEL	169	D08.4746.04 YR	172	D09.0815.02.09 MR	197	D10.0080.00.10 GR	179	D10.0813.19.10 ML	202
D08.0046.02.08 YER	169	D09.0.500.22 HM	155	D09.0917.01.09 ML	199	D10.0090.00.10 GL	179	D10.0813.19.10 MR	202

Index

simturn DX Produktverzeichnis
simturn DX Product List

Artikelnr. // Part Nr.	S/P	Artikelnr. // Part Nr.	S/P	Artikelnr. // Part Nr.	S/P	Artikelnr. // Part Nr.	S/P	Artikelnr. // Part Nr.	S/P
D10.0815.01.10 MR	199	D10.TR30.01.10 MR	201	D11.0130.00 GR	181	D11.2067.02 YR	168	D14.0078.00 ZR	183
D10.0815.02.10 ML	197	D10.TR40.01.11 ML	201	D11.0150.00 GL	181	D11.2240.01 ML	201	D14.0078.02 NL	190
D10.0815.02.10 MR	197	D10.TR40.01.11 MR	201	D11.0150.00 GR	181	D11.2240.01 MR	201	D14.0078.02 NR	190
D10.0917.01.10 ML	199	D10.UN08.02.10 ML	206	D11.0150.02 NL	189	D11.2755.02 YL	171	D14.0080.00 ZL	183
D10.0917.01.10 MR	199	D10.UN08.02.10 MR	206	D11.0150.02 NR	189	D11.2755.02 YR	171	D14.0080.00 ZR	183
D10.0917.02.10 ML	197	D10.UN13.02.10 ML	206	D11.0157.00 GL	181	D11.3067.02 YL	174	D14.0086.00 ZL	183
D10.0917.02.10 MR	197	D10.UN14.02.10 ML	206	D11.0157.00 GR	181	D11.3067.02 YR	174	D14.0086.00 ZR	183
D10.1020.01.10 ML	199	D10.UN14.02.10 MR	206	D11.0157.02 NL	189	D11.3267.04 YR	171	D14.0090.00 ZL	183
D10.1020.01.10 MR	199	D10.UN16.02.10 ML	206	D11.0157.02 NR	189	D11.4545.02 FL	173	D14.0090.00 ZR	183
D10.1020.02.10 ML	197	D10.UN16.02.10 MR	206	D11.0160.00 GL	181	D11.4545.02 FR	173	D14.0100.00 ZL	183
D10.1020.02.10 MR	197	D10.UN18.02.10 ML	206	D11.0160.00 GR	181	D11.4767.02 YL	172	D14.0100.00 ZR	183
D10.1118.14.10 ML	202	D10.UN18.02.10 MR	206	D11.0200.00 GL	181	D11.4767.02 YR	172	D14.0110.00 GL	183
D10.1118.14.10 MR	202	D10.UN20.02.10 ML	206	D11.0200.00 GR	181	D11.4767.04 YR	172	D14.0110.00 GR	183
D10.1325.01.10 ML	199	D10.UN20.02.10 MR	206	D11.0200.02 NL	189	D11.AC06.01 ML	203	D14.0117.02 NL	190
D10.1325.01.10 MR	199	D10.UN24.02.10 ML	206	D11.0200.02 NR	189	D11.AC06.01 MR	203	D14.0117.02 NR	190
D10.1325.02.10 ML	197	D10.UN24.02.10 MR	206	D11.0205.01 ML	200	D14.0.500.20 HM	158	D14.0130.00 GL	183
D10.1325.02.10 MR	197	D10.UN28.02.10 ML	206	D11.0205.01 MR	200	D14.0.500.34 HM	158	D14.0130.00 GR	183
D10.1423.11.10 ML	202	D10.UN28.02.10 MR	206	D11.0238.00 GL	181	D14.0.500.45 HM	158	D14.0150.00 GL	183
D10.1423.11.10 MR	202	D10.UN32.02.10 ML	206	D11.0238.00 GR	181	D14.0.500.64 HM	158	D14.0150.00 GR	183
D10.1630.01.10 ML	199	D10.UN32.02.10 MR	206	D11.0250.00 GL	181	D14.0.500.S.B.100 ST L	167	D14.0150.00.16 GL	184
D10.1630.01.10 MR	199	D11.0.500.29 HM	157	D11.0250.00 GR	181	D14.0.500.S.B.100 ST R	167	D14.0150.00.16 GR	184
D10.1630.02.10 ML	197	D11.0.500.42 HM	157	D11.0300.00 GL	181	D14.0.625.20 ST	164	D14.0150.00.17 GL	186
D10.1630.02.10 MR	197	D11.0.500.56 HM	157	D11.0300.00 GR	181	D14.0.625.30 ST	164	D14.0150.00.17 GR	186
D10.1856.02.10 YL	168	D11.0.500.64 HM	157	D11.0318.00 GL	181	D14.0.625.34 HM	158	D14.0150.02 NL	190
D10.1856.02.10 YR	168	D11.0.625.16 ST	163	D11.0318.00 GR	181	D14.0.625.45 HM	158	D14.0150.02 NR	190
D10.1856.02.10 YU L	170	D11.0004.08 VL	193	D11.0510.01 ML	200	D14.0.625.64 HM	158	D14.0150.02.16 NL	190
D10.1856.02.10 YU R	170	D11.0004.08 VR	193	D11.0510.01 MR	200	D14.0.625.S.B.120 ST L	167	D14.0150.02.16 NR	190
D10.1866.02.11 YL	168	D11.0006.117 VR	193	D11.0510.02 ML	197	D14.0.625.S.B.120 ST R	167	D14.0150.02.17 NL	191
D10.1866.02.11 YR	168	D11.0006.12 VL	193	D11.0510.02 MR	197	D14.0.750.25.124 ME	161	D14.0150.02.17 NR	191
D10.2056.02.10 YL	168	D11.0006.12 VR	193	D11.0810.00 PL	196	D14.0.750.S.B.120 ST L	167	D14.0157.00 GL	183
D10.2056.02.10 YR	168	D11.0008.157 VR	193	D11.0810.00 PR	196	D14.0.750.S.B.120 ST R	167	D14.0157.00 GR	183
D10.3058.02.10 YL	174	D11.0008.16 VL	193	D11.0813.19 ML	202	D14.0004.08 VL	194	D14.0157.02 NL	190
D10.3058.02.10 YR	174	D11.0008.16 VR	193	D11.0813.19 MR	202	D14.0004.08 VR	194	D14.0157.02 NR	190
D10.3068.02.11 YL	174	D11.0009.18 VL	193	D11.0815.00 PL	196	D14.0005.10 VL	194	D14.0160.00 GL	183
D10.3068.02.11 YR	174	D11.0009.18 VR	193	D11.0815.00 PR	196	D14.0005.10 VR	194	D14.0160.00 GR	183
D10.3258.02.10 YR	171	D11.0010.20 VL	193	D11.0815.01 ML	200	D14.0006.12 VL	194	D14.0198.02 NL	190
D10.4545.02.10 FL	173	D11.0010.20 VR	193	D11.0815.01 MR	200	D14.0006.12 VR	194	D14.0198.02 NR	190
D10.4545.02.10 FR	173	D11.0012.24 VL	193	D11.0815.02 ML	197	D14.0008.16 VL	194	D14.0200.00 GL	183
D10.4758.02.10 YL	172	D11.0012.24 VR	193	D11.0815.02 MR	197	D14.0008.16 VR	194	D14.0200.00 GR	183
D10.4758.02.10 YR	172	D11.0012.29 HM	157	D11.1015.01 ML	201	D14.0009.18 VL	194	D14.0200.00.16 GL	184
D10.AC05.01.11 MR	203	D11.0012.29 ST	163	D11.1015.01 MR	201	D14.0009.18 VR	194	D14.0200.00.16 GR	184
D10.AC06.01.11 ML	203	D11.0012.42 HM	157	D11.1020.01 ML	200	D14.0010.20 VL	194	D14.0200.00.17 GL	186
D10.AC06.01.11 MR	203	D11.0012.56 HM	157	D11.1020.01 MR	200	D14.0010.20 VR	194	D14.0200.00.17 GR	186
D10.AC08.01.11 ML	203	D11.0012.64 HM	157	D11.1020.02 ML	197	D14.0011.22 VL	194	D14.0200.02 NL	190
D10.AC08.01.11 MR	203	D11.0015.30 VL	193	D11.1020.02 MR	197	D14.0011.22 VR	194	D14.0200.02 NR	190
D10.NP14.02.10 ML	205	D11.0015.30 VR	193	D11.1118.14 ML	202	D14.0012.20 HM	158	D14.0200.02.16 NL	190
D10.NP14.02.10 MR	205	D11.0016.16 ST	163	D11.1118.14 MR	202	D14.0012.24 VL	194	D14.0200.02.16 NR	190
D10.NP18.02.10 ML	205	D11.0067.02.11 YEL	169	D11.1220.01 ML	201	D14.0012.24 VR	194	D14.0200.02.17 NL	191
D10.NP18.02.10 MR	205	D11.0067.02.11 YER	169	D11.1220.01 MR	201	D14.0012.34 HM	158	D14.0200.02.17 NR	191
D10.NP27.02.10 ML	205	D11.0070.00 ZL	181	D11.1325.01 ML	200	D14.0012.45 HM	158	D14.0205.02 ML	198
D10.NP27.02.10 MR	205	D11.0070.00 ZR	181	D11.1325.01 MR	200	D14.0012.64 HM	158	D14.0205.02 MR	198
D10.SA05.01.10 ML	203	D11.0078.00 ZL	181	D11.1325.02 ML	197	D14.0015.30 VL	194	D14.0238.00 GL	183
D10.SA05.01.10 MR	203	D11.0078.00 ZR	181	D11.1325.02 MR	197	D14.0015.30 VR	194	D14.0238.00 GR	183
D10.SA06.01.10 ML	203	D11.0078.02 NL	189	D11.1630.02 ML	197	D14.0016.20 ST	164	D14.0238.02 NL	190
D10.SA06.01.10 MR	203	D11.0078.02 NR	189	D11.1630.02 MR	197	D14.0016.30 ST	164	D14.0238.02 NR	190
D10.SA08.01.10 ML	203	D11.0080.00 ZL	181	D11.1730.01 ML	201	D14.0016.34 HM	158	D14.0238.02.17 NR	191
D10.SA08.01.10 MR	203	D11.0080.00 ZR	181	D11.1730.01 MR	201	D14.0016.45 HM	158	D14.0250.00 GL	183
D10.SA10.01.10 ML	203	D11.0090.00 ZL	181	D11.1855.02 YL	168	D14.0016.64 HM	158	D14.0250.00 GR	183
D10.SA10.01.10 MR	203	D11.0090.00 ZR	181	D11.1855.02 YR	168	D14.0016.75 HM	158	D14.0250.00.16 GL	184
D10.SA12.01.10 ML	203	D11.0100.00 GL	181	D11.1855.02 YU L	170	D14.0020.25.124 ME	161	D14.0250.00.16 GR	184
D10.SA12.01.10 MR	203	D11.0100.00 GR	181	D11.1855.02 YU R	170	D14.0031.62 VR	194	D14.0250.00.17 GL	186
D10.TR15.01.10 ML	201	D11.0100.02 NL	189	D11.1867.02 YL	168	D14.0062.12 VL	194	D14.0250.00.17 GR	186
D10.TR15.01.10 MR	201	D11.0100.02 NR	189	D11.1867.02 YR	168	D14.0062.12 VR	194	D14.0250.02 NL	190
D10.TR20.01.10 ML	201	D11.0110.00 GL	181	D11.1867.02 YU L	170	D14.0070.00 ZL	183	D14.0250.02 NR	190
D10.TR20.01.10 MR	201	D11.0110.00 GR	181	D11.1867.02 YU R	170	D14.0070.00 ZR	183	D14.0250.02.16 NL	190
D10.TR30.01.10 ML	201	D11.0130.00 GL	181	D11.2067.02 YL	168	D14.0078.00 ZL	183	D14.0250.02.16 NR	190

Index

simturn DX Produktverzeichnis
simturn DX Product List

Artikelnr. // Part Nr.	S/P	Artikelnr. // Part Nr.	S/P	Artikelnr. // Part Nr.	S/P	Artikelnr. // Part Nr.	S/P	Artikelnr. // Part Nr.	S/P
D14.0250.02.17 NR	191	D14.1220.52 AL	208	D14.1425.52 AR	207	D14.A.0016.60 HM L	165	D16.0200.02 NL	191
D14.0300.00 GL	183	D14.1220.52 AR	208	D14.1430.02 AL	207	D14.A.0016.60 HM R	165	D16.0200.02 NR	191
D14.0300.00 GR	183	D14.1224.02 AL	208	D14.1430.02 AR	207	D14.UN08.02.14 M R	206	D16.0250.00 GL	185
D14.0300.00.16 GL	184	D14.1224.02 AR	208	D14.1430.15 AL	210	D14.UN10.02.14 M R	206	D16.0250.00 GR	185
D14.0300.00.16 GR	184	D14.1224.52 AL	208	D14.1430.15 AR	210	D14.UN12.02.14 M R	206	D16.0300.00 GL	185
D14.0300.00.17 GL	186	D14.1224.52 AR	208	D14.1430.50 AV L	210	D16.0.500.40 HM	159	D16.0300.00 GR	185
D14.0300.00.17 GR	186	D14.1225.02 AL	208	D14.1430.50 AV R	210	D16.0.500.56 HM	159	D16.0350.00 GL	185
D14.0300.02.16 NL	190	D14.1225.02 AR	208	D14.1430.52 AL	207	D16.0.500.80 HM	159	D16.0350.00 GR	185
D14.0300.02.16 NR	190	D14.1225.12 AL	211	D14.1430.52 AR	207	D16.0.625.22 ST	163	D16.0400.00 GL	185
D14.0300.02.17 NL	191	D14.1225.12 AR	211	D14.1430.62 AR	207	D16.0.625.40 HM	159	D16.0400.00 GR	185
D14.0300.02.17 NR	191	D14.1225.50 AV L	211	D14.1432.02 AL	207	D16.0.625.56 HM	159	D16.0400.01 ML	200
D14.0318.00 GL	183	D14.1225.50 AV R	211	D14.1432.02 AR	207	D16.0.625.80 HM	159	D16.0510.01 MR	200
D14.0318.00 GR	183	D14.1225.52 AL	208	D14.1432.52 AL	207	D16.0008.16 VL	195	D16.0510.02 ML	198
D14.0318.02 NL	190	D14.1225.52 AR	208	D14.1432.52 AR	207	D16.0008.16 VR	195	D16.0510.02 MR	198
D14.0318.02 NR	190	D14.1230.02 AL	208	D14.1616.B.120 ST L	167	D16.0009.18 VL	195	D16.0810.00 PL	196
D14.0318.02.17 NR	191	D14.1230.02 AR	208	D14.1616.B.120 ST R	167	D16.0009.18 VR	195	D16.0810.00 PR	196
D14.0510.01 ML	200	D14.1230.15 AL	211	D14.1616.ST L	166	D16.0010.198 VR	195	D16.0815.00 PL	196
D14.0510.01 MR	200	D14.1230.15 AR	211	D14.1616.ST R	166	D16.0010.20 VL	195	D16.0815.00 PR	196
D14.0510.02 ML	198	D14.1230.50 AV L	211	D14.1730.01 ML	201	D16.0010.20 VR	195	D16.0815.01 ML	200
D14.0510.02 MR	198	D14.1230.50 AV R	211	D14.1730.01 MR	201	D16.0011.22 VL	195	D16.0815.01 MR	200
D14.0810.00 PL	196	D14.1230.52 AL	208	D14.1887.02 YL	168	D16.0011.22 VR	195	D16.0815.02 ML	198
D14.0810.00 PR	196	D14.1230.52 AR	208	D14.1887.02 YR	168	D16.0012.24 VL	195	D16.0815.02 MR	198
D14.0813.19 ML	202	D14.1230.62 AR	208	D14.1887.02 YU L	170	D16.0012.24 VR	195	D16.1020.01 ML	200
D14.0813.19 MR	202	D14.1232.02 AL	208	D14.1887.02 YU R	170	D16.0012.40 HM	159	D16.1020.01 MR	200
D14.0815.00 PL	196	D14.1232.02 AR	208	D14.1887.04 YL	168	D16.0012.56 HM	159	D16.1020.02 ML	198
D14.0815.00 PR	196	D14.1232.52 AL	208	D14.1887.04 YR	168	D16.0012.80 HM	159	D16.1020.02 MR	198
D14.0815.01 ML	200	D14.1232.52 AR	208	D14.2020.B.120 ST L	167	D16.0015.30 VL	195	D16.1118.14 ML	202
D14.0815.01 MR	200	D14.1325.01 ML	200	D14.2020.B.120 ST R	167	D16.0015.30 VR	195	D16.1118.14 MR	202
D14.0815.02 ML	198	D14.1325.01 MR	200	D14.2020.ST L	166	D16.0016.22 ST	163	D16.1220.01 ML	201
D14.0815.02 MR	198	D14.1325.02 ML	198	D14.2020.ST R	166	D16.0016.32 VL	195	D16.1220.01 MR	201
D14.1.000.S.B.150 ST L	167	D14.1325.02 MR	198	D14.2087.02 YL	168	D16.0016.32 VR	195	D16.1325.01 ML	200
D14.1.000.S.B.150 ST R	167	D14.1410.00 AL	207	D14.2087.02 YR	168	D16.0016.40 HM	159	D16.1325.01 MR	200
D14.1020.01 ML	200	D14.1410.00 AR	207	D14.2240.01 ML	201	D16.0016.56 HM	159	D16.1325.02 ML	198
D14.1020.01 MR	200	D14.1410.05 AL	210	D14.2240.01 MR	201	D16.0016.80 HM	159	D16.1325.02 MR	198
D14.1020.02 ML	198	D14.1410.05 AR	210	D14.2525.B.150 ST L	167	D16.0020.40 VL	195	D16.1423.11 ML	202
D14.1020.02 MR	198	D14.1411.00 AL	207	D14.2525.B.150 ST R	167	D16.0020.40 VR	195	D16.1423.11 MR	202
D14.1118.14 ML	202	D14.1411.00 AR	207	D14.2525.ST L	166	D16.0031.62 VR	195	D16.1630.02 ML	198
D14.1118.14 MR	202	D14.1412.058 AV R	210	D14.2525.ST R	166	D16.0062.12 VR	195	D16.1630.02 MR	198
D14.1210.00 AL	208	D14.1415.02 AL	207	D14.2750.01 ML	201	D16.0070.00 ZL	185	D16.1730.01 ML	201
D14.1210.00 AR	208	D14.1415.02 AR	207	D14.2750.01 MR	201	D16.0070.00 ZR	185	D16.1730.01 MR	201
D14.1210.05 AL	211	D14.1415.07 AL	210	D14.3087.02 YL	174	D16.0078.00 ZL	185	D16.1835.02 ML	198
D14.1210.05 AR	211	D14.1415.07 AR	210	D14.3087.02 YR	174	D16.0078.00 ZR	185	D16.1835.02 MR	198
D14.1211.00 AL	208	D14.1416.02 AL	207	D14.3210.02.16 YR	171	D16.0078.02 NL	191	D16.1897.02 YL	168
D14.1211.00 AR	208	D14.1416.02 AR	207	D14.3287.04 YR	171	D16.0078.02 NR	191	D16.1897.02 YR	170
D14.1212.B.100 ST L	167	D14.1416.020 AR	207	D14.3555.02 YL	171	D16.0080.00 ZL	185	D16.1897.02 YU L	170
D14.1212.B.100 ST R	167	D14.1416.08 AL	210	D14.3555.02 YR	171	D16.0080.00 ZR	185	D16.1897.02 YU R	170
D14.1212.ST L	166	D14.1416.08 AR	210	D14.4545.02 FL	173	D16.0090.00 ZL	185	D16.2140.02 ML	198
D14.1212.ST R	166	D14.1420.02 AL	207	D14.4545.02 FR	173	D16.0090.00 ZR	185	D16.2140.02 MR	198
D14.1215.02 AL	208	D14.1420.02 AR	207	D14.4710.02 YL	172	D16.0100.00 ZL	185	D16.2240.01 ML	201
D14.1215.02 AR	208	D14.1420.10 AL	210	D14.4710.02 YR	172	D16.0100.00 ZR	185	D16.2240.01 MR	201
D14.1215.07 AL	211	D14.1420.10 AR	210	D14.4787.02 YL	172	D16.0110.00 GL	185	D16.2750.01 ML	201
D14.1215.07 AR	211	D14.1420.50 AV L	210	D14.4787.02 YR	172	D16.0110.00 GR	185	D16.2750.01 MR	201
D14.1216.02 AL	208	D14.1420.50 AV R	210	D14.4787.04 YR	172	D16.0130.00 GL	185	D16.3560.01 ML	201
D14.1216.02 AR	208	D14.1420.52 AL	207	D14.A.0.625.05 ST L	165	D16.0130.00 GR	185	D16.3560.01 MR	201
D14.1216.08 AL	211	D14.1420.52 AR	207	D14.A.0.625.05 ST R	165	D16.0150.00 GL	185	D16.4055.02 YL	171
D14.1216.08 AR	211	D14.1424.02 AL	207	D14.A.0.625.20 ST L	165	D16.0150.00 GR	185	D16.4055.02 YR	171
D14.1219.02 AL	208	D14.1424.02 AR	207	D14.A.0.625.20 ST R	165	D16.0157.00 GL	185	D16.4702.02 YL	172
D14.1219.02 AR	208	D14.1424.52 AL	207	D14.A.0.625.42 HM L	165	D16.0157.00 GR	185	D16.4702.02 YR	172
D14.1220.01 ML	201	D14.1424.52 AR	207	D14.A.0.625.42 HM R	165	D16.0157.02 NL	191	D18.0.625.42 HM	160
D14.1220.01 MR	201	D14.1425.02 AL	207	D14.A.0.625.60 HM R	165	D16.0157.02 NR	191	D18.0.625.60 HM	160
D14.1220.02 AL	208	D14.1425.02 AR	207	D14.A.0.0016.05 ST L	165	D16.0157.04 NL	191	D18.0.625.85 HM	160
D14.1220.02 AR	208	D14.1425.12 AL	210	D14.A.0.0016.05 ST R	165	D16.0157.04 NR	191	D18.0.750.25 ST	164
D14.1220.10 AL	211	D14.1425.12 AR	210	D14.A.0016.20 ST L	165	D16.0160.00 GL	185	D18.0.750.40 ST	164
D14.1220.10 AR	211	D14.1425.50 AV L	210	D14.A.0016.20 ST R	165	D16.0160.00 GR	185	D18.0.750.85 HM	160
D14.1220.50 AV L	211	D14.1425.50 AV R	210	D14.A.0016.42 HM L	165	D16.0200.00 GL	185	D18.0.750.B.120 ST L	167
D14.1220.50 AV R	211	D14.1425.52 AL	207	D14.A.0016.42 HM R	165	D16.0200.00 GR	185	D18.0.750.B.120 ST R	167

Index

simturn DX Produktverzeichnis
simturn DX Product List

Artikelnr. // Part Nr.	S/P	Artikelnr. // Part Nr.	S/P
D18.0009.18.18 VR	195	D18.1630.10.02 A L	208
D18.0011.22.18 VL	195	D18.1630.10.02 A R	208
D18.0011.22.18 VR	195	D18.1640.10.02 A L	208
D18.0012.238.18 VR	195	D18.1640.10.02 A R	208
D18.0015.30.18 VL	195	D18.1830.10.02 AL	207
D18.0015.30.18 VR	195	D18.1830.10.02 AR	207
D18.0016.32.18 VL	195	D18.1840.10.02 AL	207
D18.0016.32.18 VR	195	D18.1840.10.02 AR	207
D18.0016.42 HM	160	D18.2020.B.120 ST L	167
D18.0016.60 HM	160	D18.2020.B.120 ST R	167
D18.0016.85 HM	160	D18.2020.ST L	166
D18.0020.25 ST	164	D18.2020.ST R	166
D18.0020.40 ST	164	D18.2525.B.120 ST L	167
D18.0020.40.18 VL	195	D18.2525.B.120 ST R	167
D18.0020.40.18 VR	195	D18.2525.ST L	166
D18.0020.85 HM	160	D18.2525.ST R	166
D18.0150.00.18 GL	187	D18.3014.02.20 YL	174
D18.0150.00.18 GR	187	D18.3014.02.20 YR	174
D18.0150.00.20 GL	188	D18.4712.02.18 YL	172
D18.0150.00.20 GR	188	D18.4712.02.18 YR	172
D18.0150.02.20 NL	191	D18.4714.02.20 YL	172
D18.0150.02.20 NR	191	D18.4714.02.20 YR	172
D18.0150.02.22 NL	191	D18.A.0.750.05.18 ST L	165
D18.0150.02.22 NR	191	D18.A.0.750.05.18 ST R	165
D18.0200.00.18 GL	187	D18.A.0020.05.18 ST L	165
D18.0200.00.18 GR	187	D18.A.0020.05.18 ST R	165
D18.0200.00.20 GL	188		
D18.0200.00.20 GR	188		
D18.0200.02.18 NL	191		
D18.0200.02.18 NR	191		
D18.0200.02.20 NL	191		
D18.0200.02.22 NL	191		
D18.0200.02.22 NR	191		
D18.0238.00.18 GL	187		
D18.0238.00.18 GR	187		
D18.0238.00.20 GL	188		
D18.0238.00.20 GR	188		
D18.0250.00.18 GL	187		
D18.0250.00.18 GR	187		
D18.0250.00.20 GL	188		
D18.0250.00.20 GR	188		
D18.0250.02.20 NL	191		
D18.0250.02.20 NR	191		
D18.0300.00.18 GL	187		
D18.0300.00.18 GR	187		
D18.0300.00.20 GL	188		
D18.0300.00.20 GR	188		
D18.0300.02.20 NL	191		
D18.0300.02.20 NR	191		
D18.0318.00.18 GL	187		
D18.0318.00.18 GR	187		
D18.0318.02.20 NL	191		
D18.0318.02.20 NR	191		
D18.0350.00.18 GL	187		
D18.0350.00.18 GR	187		
D18.0350.00.20 GL	188		
D18.0350.00.20 GR	188		
D18.0400.00.18 GL	187		
D18.0400.00.18 GR	187		
D18.0400.00.20 GL	188		
D18.0400.00.20 GR	188		
D18.0400.02.20 NL	191		
D18.0400.02.20 NR	191		
D18.1.000.B.120 ST L	167		
D18.1.000.B.120 ST R	167		



Nebenzeiten senken

Einfaches Handling durch Werkzeugwechsel in der Maschine und selbstzentrierendem Plattensitz.

Reduction of idle-times

Easy handling by changing tools in the machine and self-centering insert seat.



Maximales Preis-Leistungsverhältnis

3 präzisionsgeschliffene Schneiden in Bohrungen ab Ø 7,8 mm mit sehr hoher Wiederholgenauigkeit.

Maximum price-performance ratio

3 precision ground cutting edges in bores starting at Ø 7.8 mm with very high repeat accuracy.



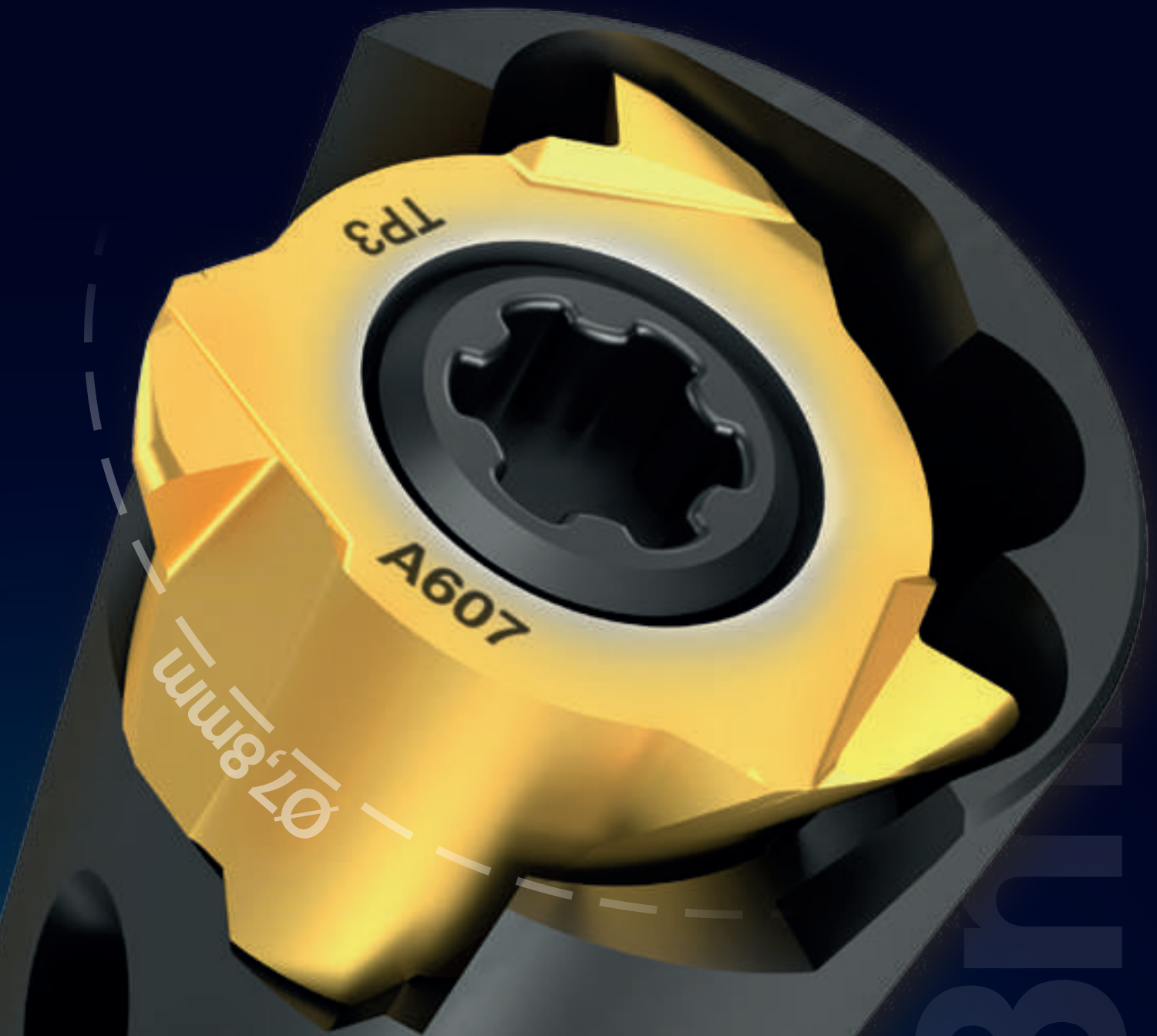
Optimaler Schneidenschutz

Spezieller Schutz der beiden passiven Schneiden vor Beschädigungen.

Optimal protection of cutting edges

Special protection of the both passive cutting edges against damage.

Ø 7,8mm
simturn PX



Ausdrehen
**neu erfunden. Boring
reinvented.**

Das System im Detail The system details

Bitte beachten Sie die allgemeinen Gebrauchshinweise auf Seite
 Please read the general instructions for use on page

433

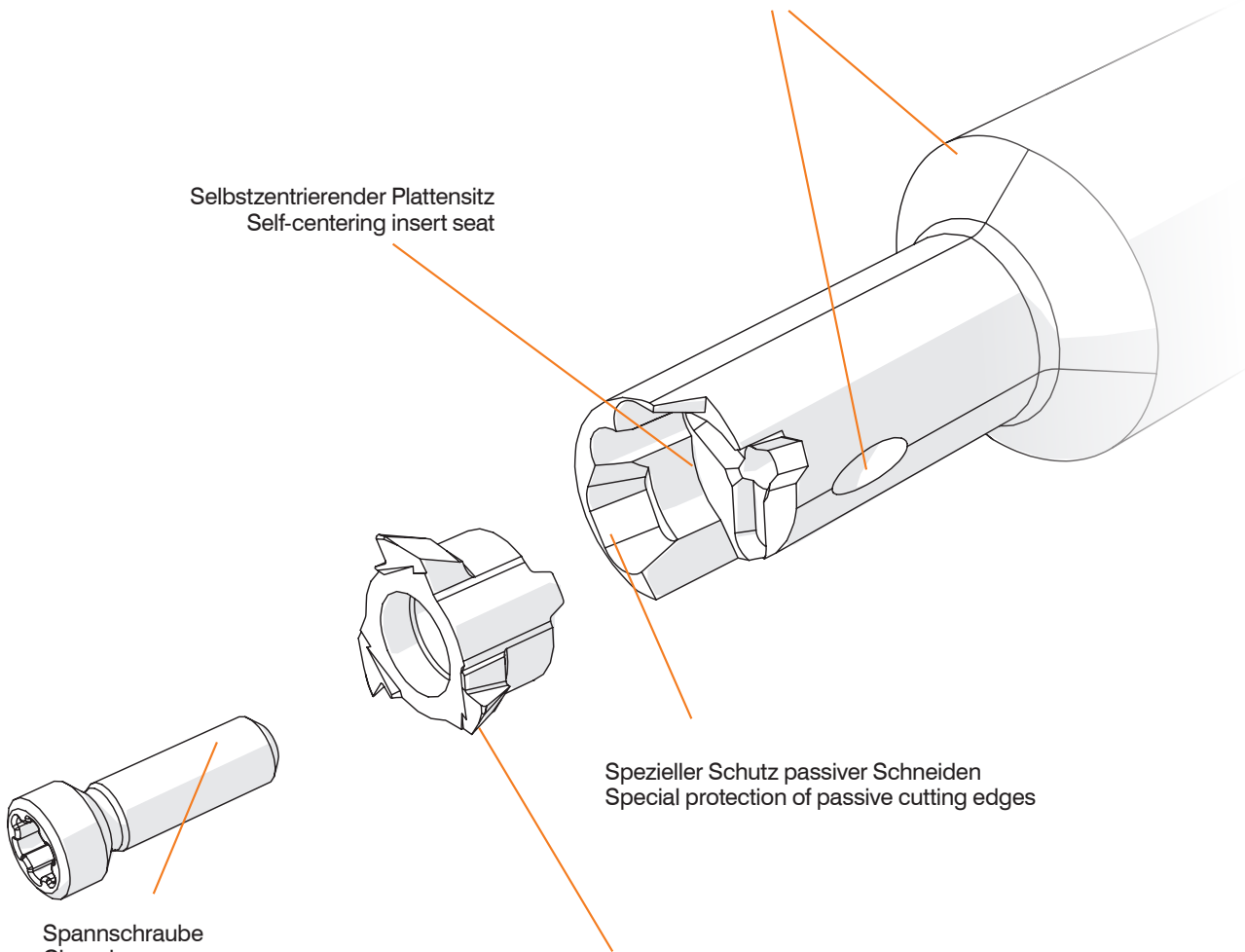
Schwingungsgedämpfter Hartmetallschaft oder Stahlschaft mit innerer Kühlmittelzufuhr
 Anti-vibration solid carbide shank or steel shank with through coolant supply

Selbstzentrierender Plattensitz
 Self-centering insert seat

Spezieller Schutz passiver Schneiden
 Special protection of passive cutting edges

Spannschraube
 Clamping screw

Präzisionsgeschliffenes, dreischneidiges Schneidwerkzeug.
 Precision ground cutting insert with three cutting edges



Klemmhalter, Innenbearbeitung

Schwingungsgedämpfter Hartmetall-Rundschaft mit innerer Kühlmittelzufuhr. Kühlmittelauslass auf linker oder rechter Halterseite.

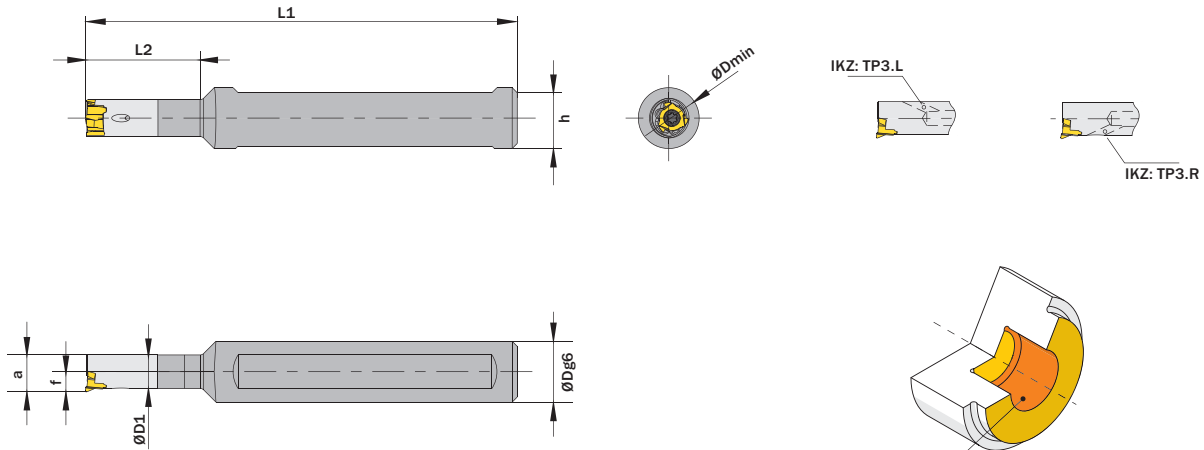
Toolholder, For Internal Applications

Anti-vibration solid carbide round shank toolholder with through coolant. Coolant exit on left or right handed side of the toolholder.

Anzugsmoment (Schraube) // Tightening torque (screw)
0,8 Nm

SP HM **Legende Legend 224**

Scan QR-Code Oder besuchen Sie // Or Visit www.simtek.info/cp/1377



Maße „a“ und „f“ sind abhängig vom verwendeten Schneideinsatz.
Dimensions „a“ und „f“ depend on used carbide inserts.

Abbildung zeigt / Drawing shows: TP3.R08.0012.23 HM R

- **Hauptsächlich geeignet für diese Flächen**
Mainly designed for these surfaces
- **Je nach Schneidplatte ebenfalls möglich**
Also possible depending on insert type

ØD ^{h6} mm	L2 mm	ØDmin (Min. Bohrung) ØDmin (min. bore) mm	Artikelnummer Part number	Webcode www.simtek.com/webcode	d1 mm	h mm	L1 mm	Schraube Screw	Schraubenschlüssel Screw driver	Connectcode www.simtek.com/code	
▼ L2 = 26,0 mm											
12,0	26,0	7,8	TP3.L08.0012.26 HM R	A6Z1	6,6	11,0	92,0	D M2x7,5 T7F	T7F	TP3R.08	new
12,0	26,0	7,8	TP3.R08.0012.26 HM R	A6ZZ	6,6	11,0	92,0	D M2x7,5 T7F	T7F	TP3R.08	new
▼ L2 = 39,0 mm											
12,0	39,0	7,8	TP3.L08.0012.39 HM R	A6Z5	6,6	11,0	107,0	D M2x7,5 T7F	T7F	TP3R.08	new
12,0	39,0	7,8	TP3.R08.0012.39 HM R	A6Z3	6,6	11,0	107,0	D M2x7,5 T7F	T7F	TP3R.08	new
▼ L2 = 53,0 mm											
12,0	53,0	7,8	TP3.L08.0012.53 HM R	A6ØD	6,6	11,0	117,0	D M2x7,5 T7F	T7F	TP3R.08	new
12,0	53,0	7,8	TP3.R08.0012.53 HM R	A6ØB	6,6	11,0	117,0	D M2x7,5 T7F	T7F	TP3R.08	new

Bestellbeispiel // Order example: **TP3.R08.0012.23 HM R** (R = Rechte Ausführung // Right hand version)

TP3.L: Wir empfehlen den Einsatz dieser Trägerwerkzeuge ausschließlich für das Ausdrehen von Sacklochbohrungen.
We recommend the use of these toolholders only for the boring of blind holes.

Klemmhalter, Innenbearbeitung

Stahl-Rundschaft mit innerer Kühlmittelzufuhr.
Kühlmittelauslass auf linker oder rechter Halterseite.

Toolholder, For Internal Applications

Steel round shank toolholder with through coolant.
Coolant exit on the left or right side of the toolholder.

Anzugsmoment (Schraube) // Tightening torque (screw)

0,8 Nm

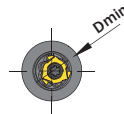
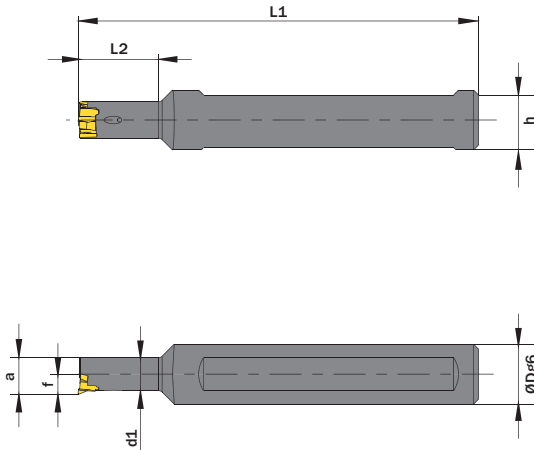


Legende
Legend **224**

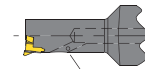
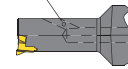


Scan
QR-Code

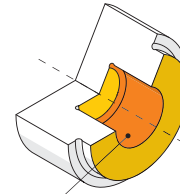
Oder besuchen Sie // Or Visit
www.simtek.info/cp/1376



IKZ: TP3.L



IKZ: TP3.R



- Hauptsächlich geeignet für diese Flächen
Mainly designed for these surfaces
- Je nach Schneidplatte ebenfalls möglich
Also possible depending on insert type

Abbildung zeigt / Drawing shows: TP3.R08.0012.16 ST R

ØD _{g6}	L2	ØD _{min} (Min. Bohrung) ØD _{min} (min. bore)	Artikelnummer Part number	Webcode www.simtek.com/webcode	D1	h	L1	Schraube Screw	Schraubenschlüssel Screw driver	Connectcode www.simtek.com/code	
mm	mm	mm			mm	mm	mm				
▼ L2 = 6,6 mm											
12,0	6,6	7,8	TP3.L08.0012.06 ST R	A6ZT	6,6	11,0	80,0	D M2x7,5 T7F	T7F	TP3R.08	new
12,0	6,6	7,8	TP3.R08.0012.06 ST R	A6ZQ	6,6	11,0	80,0	D M2x7,5 T7F	T7F	TP3R.08	new
▼ L2 = 16,5 mm											
12,0	16,5	7,8	TP3.L08.0012.16 ST R	A6ZX	6,6	11,0	80,0	D M2x7,5 T7F	T7F	TP3R.08	new
12,0	16,5	7,8	TP3.R08.0012.16 ST R	A6ZV	6,6	11,0	80,0	D M2x7,5 T7F	T7F	TP3R.08	new

Bestellbeispiel // Order example: **TP3.R08.0012.16 ST R** (R = Rechte Ausführung // Right hand version)

TP3.L: Wir empfehlen den Einsatz dieser Trägerwerkzeuge ausschließlich für das Audreihen von Sacklochbohrungen.
We recommend the use of these toolholders only for the boring of blind holes.

Ausdrehen

Geeignet ab Bohrungsdurchmesser 7,8 mm.

Boring

For use in bores as of minimum bore diameter 7,8 mm.

Schnittwerte (Start) // Cutting parameters (start)

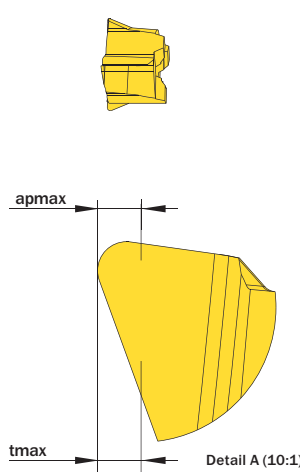
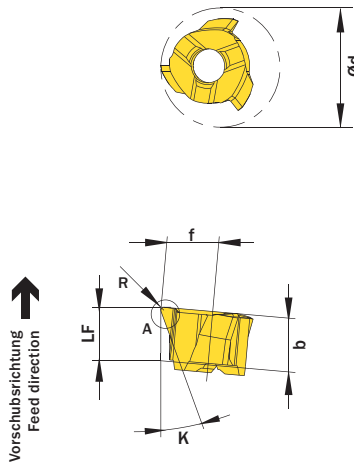
f	Vc
0,02 mm/U	Seite/Page 429

Passende Klemmhalter auf Seite // Suitable toolholders on page 221, 222

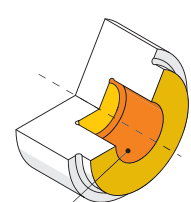
SP **HM** **R**

Legende Legend 224

Scan QR-Code Oder besuchen Sie // Or Visit www.simtek.info/cp/1375



Abbildungen ähnlich // Similar illustrations



- Hauptsächlich geeignet für diese Flächen
Mainly designed for these surfaces
- Je nach Schneidplatte ebenfalls möglich
Also possible depending on insert type



Abbildung zeigt / Drawing shows: TP3.1808.020.08 Y R

ØDmin (Min. Bohrung) ØDmin (min. bore)	K	R	Artikelnummer Part number	Webcode www.simtek.com/webcode	Unsere erste Wahl Our first choice				tmax	apmax	LF	f	b	Connectcode www.simtek.com/code	
					P	K	M	S							
▼ R = 0,1 mm															
7,8	20°	0,1	TP3.2008.010.08 YBR	A61N	X800	X400			0,3	0,3	3,4	3,5	3,5	TP3R.08	new
▼ R = 0,2 mm															
7,8	18°	0,2	TP3.1808.020.08 YR	A607	X800	X400			0,3	0,3	3,4	3,5	3,5	TP3R.08	new
7,8	18°	0,2	TP3.1808.020.08 YER	A609	X800	X400			0,3	0,25	3,4	3,5	3,5	TP3R.08	new
7,8	32°	0,2	TP3.3208.020.08 YR	A61B	X800	X400			0,3	0,3	3,4	3,5	3,5	TP3R.08	new
7,8	32°	0,2	TP3.3208.020.08 YER	A61F	X800	X400			0,3	0,25	3,4	3,5	3,5	TP3R.08	new
7,8	47°	0,2	TP3.4708.020.08 YR	A61H	X800	X400			0,3	0,3	3,4	3,5	3,5	TP3R.08	new
7,8	47°	0,2	TP3.4708.020.08 YER	A61K	X800	X400			0,3	0,25	3,4	3,5	3,5	TP3R.08	new

Bestellbeispiel // Order example: TP3.2008.010.08 YBR X800 (R = Rechte Ausführung // Right hand version, X800 = Schneidstoff // Grade)

Info

Legende
Legend

- SP** Schneidwerkzeug aus Hartmetall // Carbide insert // Outils coupants en carbure de tungstène // Inserto in metallo duro
HM Inserto de carburo // Karbür kesici uç
- TW** Trägerwerkzeug aus Stahl // Steel toolholder // Porte-outils en acier // Porta inserto in acciaio
ST Porta-herramientas de acero // Çelik tutucu
- R** Rechts wie gezeichnet // Right hand version shown, left hand version inversely // A droite comme présenté // In figura utensile destro
 Modelo derecho // Sağ model
-  Innere Kühlmittelzufuhr // Through coolant // Refroidissement interne // Lubrificazione interna
 Con refrigeración interna // İçten soğutma
-  Schwingungsgedämpft // Anti-vibration // Anti vibration // Antivibrante // Anti-vibración // Anti vibrasyon

Index

simturn PX Produktverzeichnis simturn PX Product List

Artikelnr. // Part Nr.	S/P
TP3.1808.020.08 YER	223
TP3.1808.020.08 YR	223
TP3.2008.010.08 YBR	223
TP3.3208.020.08 YER	223
TP3.3208.020.08 YR	223
TP3.4708.020.08 YER	223
TP3.4708.020.08 YR	223
TP3.L08.0.500.06 ST R	222
TP3.L08.0.500.16 ST R	222
TP3.L08.0.500.23 HM R	222
TP3.L08.0.500.33 HM R	222
TP3.L08.0.500.42 HM R	222
TP3.L08.0.500.50 HM R	222
TP3.L08.0012.06 ST R	222
TP3.L08.0012.16 ST R	222
TP3.L08.0012.23 HM R	221
TP3.L08.0012.33 HM R	221
TP3.L08.0012.42 HM R	221
TP3.L08.0012.50 HM R	221
TP3.R08.0500.06 ST R	222
TP3.R08.0500.16 ST R	222
TP3.R08.0.500.23 HM R	221
TP3.R08.0.500.33 HM R	221
TP3.R08.0.500.42 HM R	221
TP3.R08.0.500.50 HM R	221
TP3.R08.0012.06 ST R	222
TP3.R08.0012.16 ST R	222
TP3.R08.0012.23 HM R	221
TP3.R08.0012.33 HM R	221
TP3.R08.0012.42 HM R	221
TP3.R08.0012.50 HM R	221

simturn AX

simturn DX

simturn PX

simturn H2

simturn K2

simturn C4

simturn GX

simturn E3

simturn E12

simturn FX

simturn
Decolletage

simturn OA

Index

225

Das Werkzeugsystem im Überblick
The Tool System Overview

Zweischneidig **außen** und in **kleinen Bohrungen**.

Two cutting edges **external** and in **small bores**.

Alle Anwendungen auf einen Blick // All applications at one glance

Nutenstechen · Einstechen und Profildrehen · Abstechen
Grooving · Grooving and Profiling · Parting-Off

Detaillierte Übersicht aller Anwendungen ab Seite 229
Detailed overview of all applications as of page 229

Hauptanwendungen // Main Applications

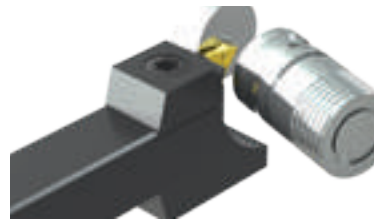
Nutenstechen Grooving



Wendeschneidplatten zur Herstellung von Sicherungsringnuten innen und außen nach DIN 471/472, sowie DIN 983/984. Nutnennbreiten von 1,1 mm bis 4,15 mm.

Indexable inserts for the machining of circlip ring grooves according to DIN 471/472 as well as DIN 983/984. Nominal width of grooves from 1,1 mm up to 4,15 mm.

Abstechen Parting-Off



Abstechwerkzeuge in verschiedenen Breiten und mit verschiedenen Winkeln. Mit spezieller Spanformgeometrie für das Abstechen von Bauteilen mit Durchmessern bis zu Ø 36,0 mm.

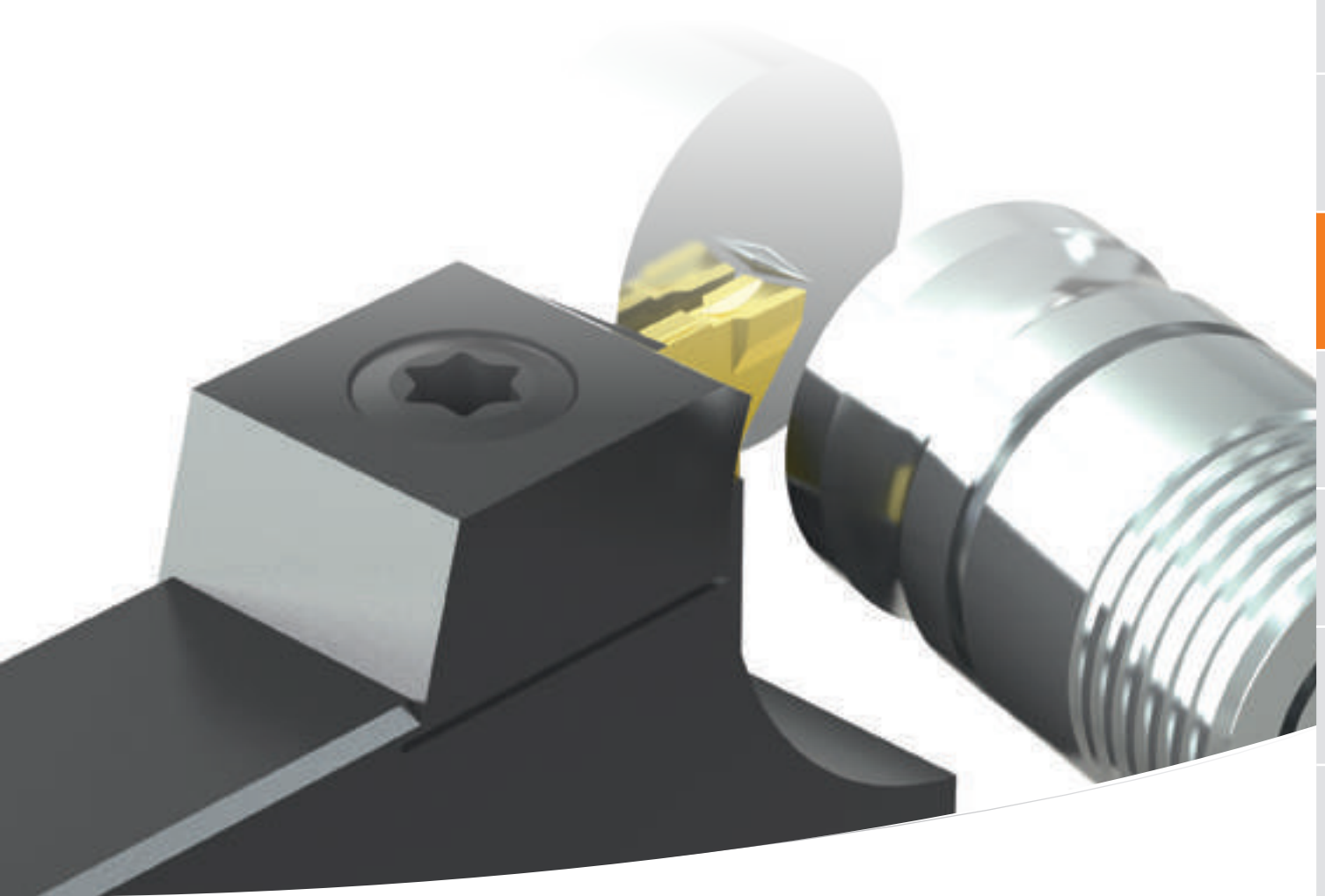
Parting-off inserts with different cutting edge widths and with different angles. With special chip forming geometry for the parting-off of components with diameters up to Ø 36,0 mm.

Einstechen und Profildrehen Grooving and Profiling



CNC-Konturdrehen mit unterschiedlichen Schneidenbreiten und Eckenradien. Mit Spanformgeometrie für optimale Spankontrolle oder spezieller Schneidengeometrie für die Bearbeitung von Leichtmetallen. Auch als Vollradiusvariante verfügbar.

CNC-Profiling with different cutting edge widths and corner radii. With chip forming geometry for optimal chip control or special cutting edge geometry for the machining of light alloys. Also available as full radius tools.



Werkzeugsystem bestehend aus zweischneidigen Hartmetall-Schneidplatten und Stahlträgerwerkzeug. Einsetzbar in Bohrungen ab \varnothing 24,5 mm.

Das Schneidwerkzeug, und in speziellem Maße die Schneide, ist auf optimale Spankontrolle und Leistung ausgelegt.

Das spezielle Design des Plattensitzes begünstigt eine optimale Kraftaufnahme und Stabilität.

Tool system of double-edged carbide insert and steel toolholder. For use in bores as of \varnothing 24,5 mm.

The cutting insert and especially the cutting edge was designed to offer best chip control and improved performance in bores.

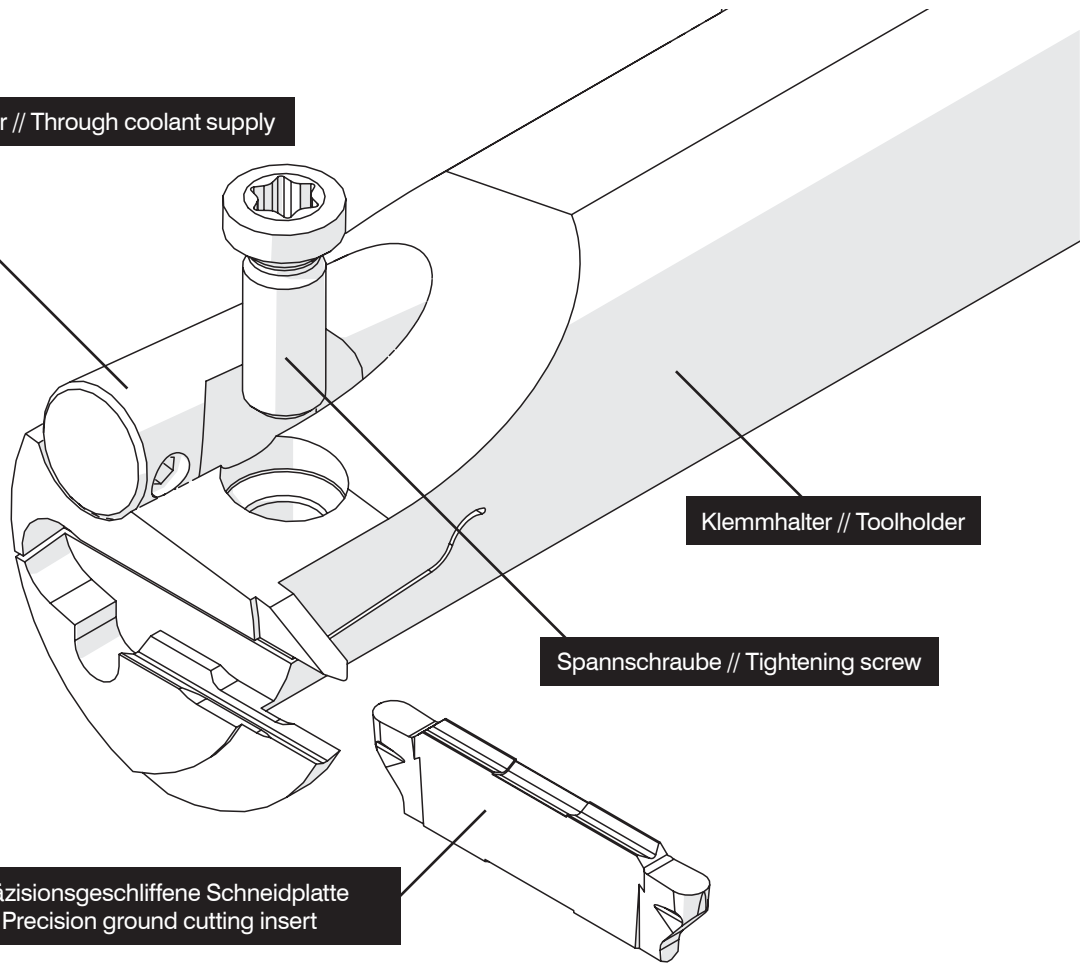
The special insert seat design enhances the overall stability and cutting force absorption and leads to improved results.

Das System im Detail
 The system details

Bitte beachten Sie die allgemeinen Gebrauchshinweise auf Seite
 Please read the general instructions for use on page

433

Kühlmittelzufuhr // Through coolant supply



Klemmhalter // Toolholder

Spannschraube // Tightening screw

Präzisionsgeschliffene Schneidplatte
 Precision ground cutting insert

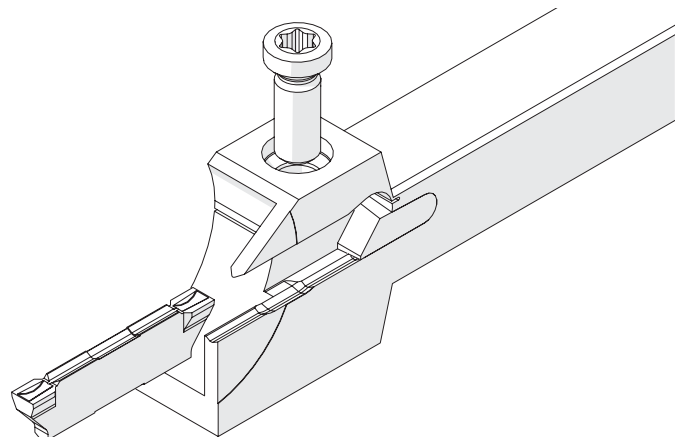
Verfügbar für die Innen- und Außenbearbeitung
Available for internal and external applications

Innen // Internal

Ab Bohrungsdurchmesser 24,5 mm
 As of bore diameter 24,5 mm

Außen // External

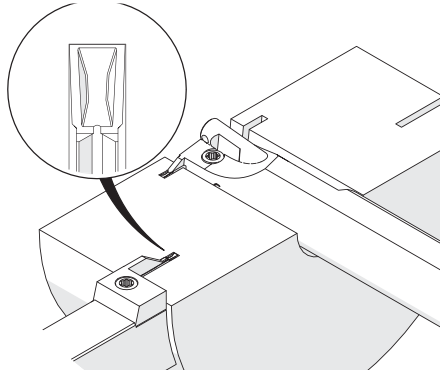
Maximale Stechtiefe 18,0 mm
 Maximum cutting depth 18,0 mm



Standardanwendungen Standard Applications

Seite
Page

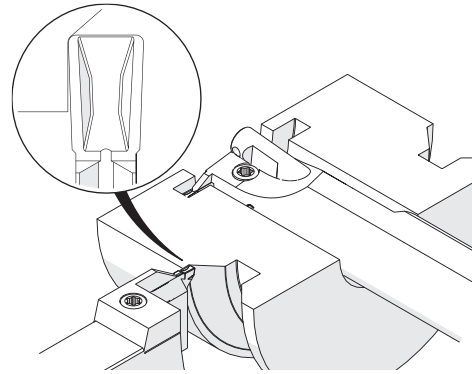
244



Stechdrehen, Sicherungsringnuten
Grooving, Circlip Ring Grooves

Ab Seite
As of page

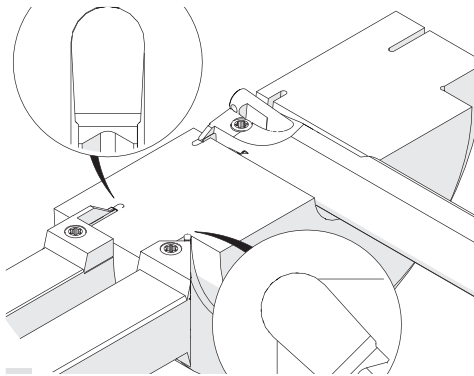
246



Einstecken und Profildrehen
Grooving and Profiling

Seite
Page

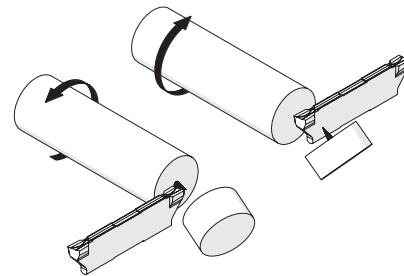
247



Einstecken und Profildrehen, Vollradius
Grooving and Profiling, Full Radius

Ab Seite
As of page

248



Abstechen
Parting off

simturn AX

simturn DX

simturn PX

simturn H2

simturn K2

simturn C4

simturn GX

simturn E3

simturn E12

simturn FX

simturn
Decolletage

simturn OA

Index

229

Klemmhalter, Innen, Typ A

Klemmhalter für die Innenbearbeitung ab Bohrungsdurchmesser 24,5 mm. Mit spezieller Kühlmitteldüse für verbesserte Spankontrolle.

Toolholder, Internal, Type A

Toolholder for internal applications as of bore diameter 24,5 mm. Equipped with special through coolant nozzle for improved chip control.

Anzugsmoment (Schraube) // Tightening torque (screw)

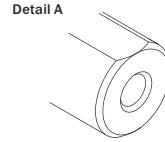
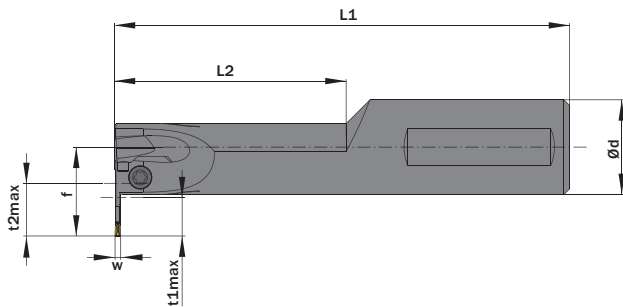
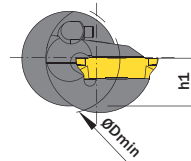
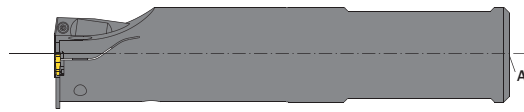
- TH2.15: 1,5 Nm
- TH2.20: 2,0 Nm
- TH2.25: 2,5 Nm
- TH2.30: 3,0 Nm
- TH2.40: 3,0 Nm



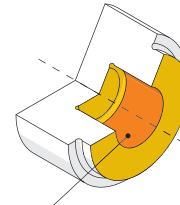
TW
ST
R
🔥
Legende
Legend
250

Scan QR-Code
 Oder besuchen Sie // Or Visit
www.simtek.info/cp/474

Für kleinere Bohrungen
For smaller bores



Detail A
Anschlussgewinde G 1/8"
Connection thread G 1/8"



- Hauptsächlich geeignet für diese Flächen
Mainly designed for these surfaces
- Je nach Schneidplatte ebenfalls möglich
Also possible depending on insert type

Abbildung zeigt / Drawing shows: TH2.0025.A31.61.12.15 R

Ød ^{g6} mm	ØDmin (Min. Bohrung) ØDmin (min. bore) mm	L2 mm	L1 mm	Artikelnummer Part number	Webcode www.simtek.com/webcode	f mm	h1 ^{js14} mm	t1max mm	t2max mm	w ≥ mm	w ≤ mm	Schraube Screw	Schraubenschlüssel Screw driver	Connectcode www.simtek.com/code		
▼ Ød = 19,05 mm																
19,05	24,5	48,0	120,0	TH2.0.750.A25.48.12.15 R/L	R A1E2 L A1E1	18,0	8,5	7,0	12,5	-	1,9	TH2 M4x12 T15F	T15F	TH2.15		Inch
19,05	24,5	48,0	120,0	TH2.0.750.A25.48.12.20 R/L	R A1E4 L A1E3	18,0	8,5	7,0	12,5	1,91	2,4	TH2 M4x12 T15F	T15F	TH2.20		Inch
19,05	24,5	48,0	120,0	TH2.0.750.A25.48.12.25 R/L	R A1E6 L A1E5	18,0	8,5	7,0	12,5	2,41	2,9	TH2 M4x12 T15F	T15F	TH2.25		Inch
19,05	24,5	48,0	120,0	TH2.0.750.A25.48.12.30 R/L	R A1E7 L A1FA	18,0	8,5	7,0	12,5	2,91	3,8	TH2 M4x12 T15F	T15F	TH2.30		Inch
19,05	24,5	48,0	120,0	TH2.0.750.A25.48.12.40 R/L	R A1E9 L A1E8	18,0	8,5	7,0	12,5	3,81	4,9	TH2 M4x12 T15F	T15F	TH2.40		Inch
▼ Ød = 20,0 mm																
20,0	24,5	48,0	120,0	TH2.0020.A25.48.11.15 R/L	R ASVG L ASVF	18,0	9,0	7,0	12,5	-	1,9	TH2 M4x12 T15F	T15F	TH2.15		
20,0	24,5	48,0	120,0	TH2.0020.A25.48.11.20 R/L	R ASVJ L ASVH	18,0	9,0	7,0	12,5	1,91	2,4	TH2 M4x12 T15F	T15F	TH2.20		
20,0	24,5	48,0	120,0	TH2.0020.A25.48.11.25 R/L	R ASVM L ASVK	18,0	9,0	7,0	12,5	2,41	2,9	TH2 M4x12 T15F	T15F	TH2.25		
20,0	24,5	48,0	120,0	TH2.0020.A25.48.11.30 R/L	R ASVP L ASVN	18,0	9,0	7,0	12,5	2,91	3,8	TH2 M4x12 T15F	T15F	TH2.30		
20,0	24,5	48,0	120,0	TH2.0020.A25.48.11.40 R/L	R ASVS L ASVQ	18,0	9,0	7,0	12,5	3,81	4,9	TH2 M4x12 T15F	T15F	TH2.40		
▼ Ød = 25,0 mm																
25,0	27,0	48,0	120,0	TH2.0025.A25.48.12.15 R/L	R ASWE L ASWD	20,5	11,5	7,0	15,0	-	1,9	TH2 M4x12 T15F	T15F	TH2.15		
25,0	27,0	48,0	120,0	TH2.0025.A25.48.12.20 R/L	R ASWG L ASWF	20,5	11,5	7,0	15,0	1,91	2,4	TH2 M4x12 T15F	T15F	TH2.20		
25,0	27,0	48,0	120,0	TH2.0025.A25.48.12.25 R/L	R ASWJ L ASWH	20,5	11,5	7,0	15,0	2,41	2,9	TH2 M4x12 T15F	T15F	TH2.25		
25,0	27,0	48,0	120,0	TH2.0025.A25.48.12.30 R/L	R ASWM L ASWK	20,5	11,5	7,0	15,0	2,91	3,8	TH2 M4x12 T15F	T15F	TH2.30		
25,0	27,0	48,0	120,0	TH2.0025.A25.48.12.40 R/L	R ASWP L ASWN	20,5	11,5	7,0	15,0	3,81	4,9	TH2 M4x12 T15F	T15F	TH2.40		
▼ Ød = 25,4 mm																
25,4	27,0	48,0	120,0	TH2.1.000.A25.48.12.15 R/L	R AW6A L AW59	20,7	11,7	7,0	15,0	-	1,9	TH2 M4x12 T15F	T15F	TH2.15		Inch
25,4	27,0	48,0	120,0	TH2.1.000.A25.48.12.20 R/L	R AW6C L AW6B	20,7	11,7	7,0	15,0	1,91	2,4	TH2 M4x12 T15F	T15F	TH2.20		Inch
25,4	27,0	48,0	120,0	TH2.1.000.A25.48.12.25 R/L	R AW6E L AW6D	20,7	11,7	7,0	15,0	2,41	2,9	TH2 M4x12 T15F	T15F	TH2.25		Inch
25,4	27,0	48,0	120,0	TH2.1.000.A25.48.12.30 R/L	R AW6G L AW6F	20,7	11,7	7,0	15,0	2,91	3,8	TH2 M4x12 T15F	T15F	TH2.30		Inch
25,4	27,0	48,0	120,0	TH2.1.000.A25.48.12.40 R/L	R AW6J L AW6H	20,7	11,7	7,0	15,0	3,81	4,9	TH2 M4x12 T15F	T15F	TH2.40		Inch

Verwandte Werkzeuge finden Sie auch auf der folgenden Seite!
Related Items can be found on the following page as well!

Fortgesetzte Tabelle
Continued Table

Bestellbeispiel // Order example: TH2.0020.A25.48.11.15 R (R = Rechte Ausführung // Right hand version)

Klemmhalter, Innen, Typ A

Klemmhalter für die Innenbearbeitung ab Bohrungsdurchmesser 31,0 mm. Mit spezieller Kühlmitteldüse für verbesserte Spankontrolle.

Toolholder, Internal, Type A

Toolholder for internal applications as of bore diameter 31,0 mm. Equipped with special through coolant nozzle for improved chip control.

Anzugsmoment (Schraube) // Tightening torque (screw)

- TH2.15: 1,5 Nm
- TH2.20: 2,0 Nm
- TH2.25: 2,5 Nm
- TH2.30: 3,0 Nm
- TH2.40: 3,0 Nm



Legende
Legend 250

Scan QR-Code

Oder besuchen Sie // Or Visit
www.simtek.info/cp/860

Für größere Bohrungen
For bigger bores

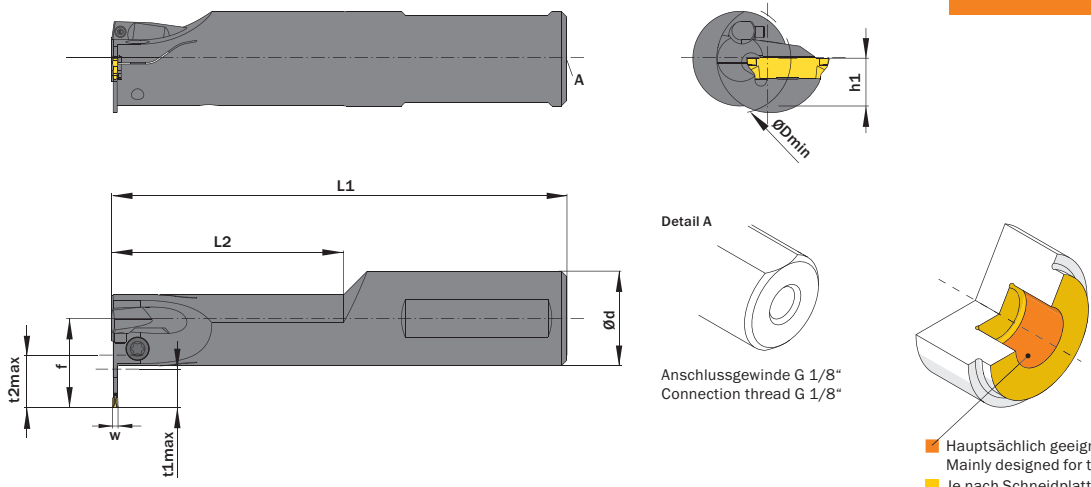


Abbildung zeigt / Drawing shows: TH2.0025.A31.61.12.15 R

- Hauptsächlich geeignet für diese Flächen
Mainly designed for these surfaces
- Je nach Schneidplatte ebenfalls möglich
Also possible depending on insert type

Ød ⁶	ØDmin (Min. Bohrung) ØDmin (min. bore)	L2	L1	Artikelnummer Part number	Webcode www.simtek.com/webcode	f	h1 ^{js14}	t1max	t2max	w ≥	w ≤	Schraube Screw	Schraubenschlüssel Screw driver	Connectcode www.simtek.com/cocode
-----------------	---	----	----	------------------------------	---	---	--------------------	-------	-------	-----	-----	-------------------	------------------------------------	---

Fortgesetzte Tabelle Continued Table
Verwandte Werkzeuge finden Sie auch auf der vorhergehenden Seite!
Related items can be found on the previous page as well!

▼ Ød = 25,0 mm														
25,0	31,0	61,0	120,0	TH2.0025.A31.61.12.15 R/L	R ASWS L ASWQ	23,5	11,5	10,0	16,5	-	1,9	TH2 M4x12 T15F	T15F	TH2.15
25,0	31,0	61,0	120,0	TH2.0025.A31.61.12.20 R/L	R ASWU L ASWT	23,5	11,5	10,0	16,5	1,91	2,4	TH2 M4x12 T15F	T15F	TH2.20
25,0	31,0	61,0	120,0	TH2.0025.A31.61.12.25 R/L	R ASWW L ASWV	23,5	11,5	10,0	16,5	2,41	2,9	TH2 M4x12 T15F	T15F	TH2.25
25,0	31,0	61,0	120,0	TH2.0025.A31.61.12.30 R/L	R ASWY L ASWX	23,5	11,5	10,0	16,5	2,91	3,8	TH2 M4x12 T15F	T15F	TH2.30
25,0	31,0	61,0	120,0	TH2.0025.A31.61.12.40 R/L	R ASWØ L ASWZ	23,5	11,5	10,0	16,5	3,81	4,9	TH2 M4x12 T15F	T15F	TH2.40
▼ Ød = 25,4 mm														
25,4	31,0	61,0	120,0	TH2.1.000.A31.61.12.15 R/L	R AW6M L AW6K	23,7	11,7	10,0	16,5	-	1,9	TH2 M4x12 T15F	T15F	TH2.15 inch
25,4	31,0	61,0	120,0	TH2.1.000.A31.61.12.20 R/L	R AW6P L AW6N	23,7	11,7	10,0	16,5	1,91	2,4	TH2 M4x12 T15F	T15F	TH2.20 inch
25,4	31,0	61,0	120,0	TH2.1.000.A31.61.12.25 R/L	R AW6S L AW6Q	23,7	11,7	10,0	16,5	2,41	2,9	TH2 M4x12 T15F	T15F	TH2.25 inch
25,4	31,0	61,0	120,0	TH2.1.000.A31.61.12.30 R/L	R AW6U L AW6T	23,7	11,7	10,0	16,5	2,91	3,8	TH2 M4x12 T15F	T15F	TH2.30 inch
25,4	31,0	61,0	120,0	TH2.1.000.A31.61.12.40 R/L	R AW6W L AW6V	23,7	11,7	10,0	16,5	3,81	4,9	TH2 M4x12 T15F	T15F	TH2.40 inch
▼ Ød = 32,0 mm														
32,0	34,0	61,0	120,0	TH2.0032.A31.61.12.15 R/L	R ASXØ L ASXZ	27,0	15,0	10,0	16,5	-	1,9	TH2 M5x12 T20F	T20F	TH2.15
32,0	34,0	61,0	120,0	TH2.0032.A31.61.12.20 R/L	R ASX2 L ASX1	27,0	15,0	10,0	16,5	1,91	2,4	TH2 M5x12 T20F	T20F	TH2.20
32,0	34,0	61,0	120,0	TH2.0032.A31.61.12.25 R/L	R ASX4 L ASX3	27,0	15,0	10,0	16,5	2,41	2,9	TH2 M5x12 T20F	T20F	TH2.25
32,0	34,0	61,0	120,0	TH2.0032.A31.61.12.30 R/L	R ASX6 L ASX5	27,0	15,0	10,0	16,5	2,91	3,8	TH2 M5x12 T20F	T20F	TH2.30
32,0	34,0	61,0	120,0	TH2.0032.A31.61.12.40 R/L	R ASX8 L ASX7	27,0	15,0	10,0	16,5	3,81	4,9	TH2 M5x12 T20F	T20F	TH2.40

Bestellbeispiel // Order example: TH2.0025.A31.61.12.20 R (R = Rechte Ausführung // Right hand version)

simturn AX
simturn DX
simturn PX
simturn H2
simturn K2
simturn C4
simturn GX
simturn E3
simturn E12
simturn FX
simturn Decolletage
simturn OA
Index

Klemmhalter, Innen, Typ B

Klemmhalter für die Innenbearbeitung ab Bohrungsdurchmesser 24,5 mm. Ohne innere Kühlmittelzufuhr.

Toolholder, Internal, Type B

Toolholder for internal applications as of bore diameter 24,5 mm. Without through coolant.

Anzugsmoment (Schraube) // Tightening torque (screw)

- TH2.15: 1,5 Nm
- TH2.20: 2,0 Nm
- TH2.25: 2,5 Nm
- TH2.30: 3,0 Nm
- TH2.40: 3,0 Nm



TW **ST** **R** Legende **250**
Legend

Scan QR-Code Oder besuchen Sie // Or Visit www.simtek.info/cp/477

Für kleinere Bohrungen
For smaller bores

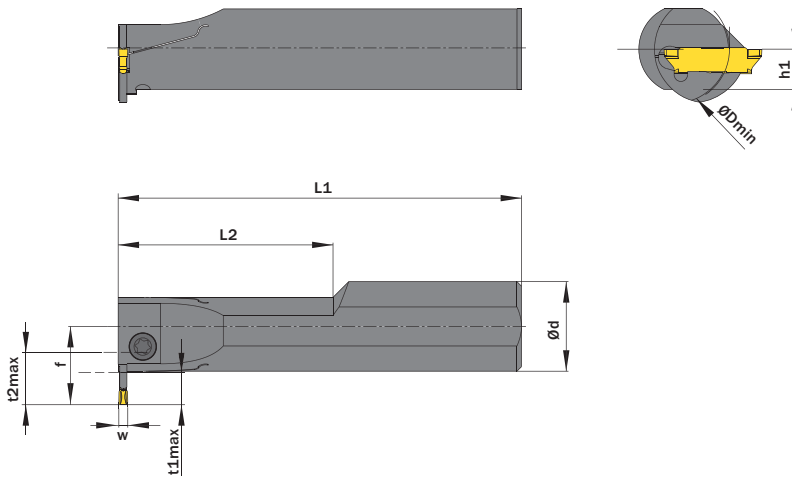
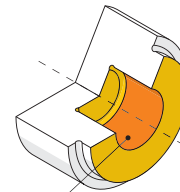


Abbildung zeigt / Drawing shows: TH2.0020.B25.48.11.20 R



- Hauptsächlich geeignet für diese Flächen
Mainly designed for these surfaces
- Je nach Schneidplatte ebenfalls möglich
Also possible depending on insert type

Ød ^{g6}	ØDmin (Min. Bohrung) ØDmin (min. bore)	L2	L1	Artikelnummer Part number	Webcode www.simtek.com/webcode	f	h1 ^{js14}	t1max	t2max	w ≥	w ≤	Schraube Screw	Schraubenschlüssel Screw driver	Connectcode www.simtek.com/code
▼ Ød = 20,0 mm														
20,0	24,5	48,0	120,0	TH2.0020.B25.48.11.15 R/L	ASVU L ASVT	18,0	9,0	7,0	12,5	-	1,9	TH2 M4x12 T15F	T15F	TH2.15
20,0	24,5	48,0	120,0	TH2.0020.B25.48.11.20 R/L	ASVW L ASVV	18,0	9,0	7,0	12,5	1,91	2,4	TH2 M4x12 T15F	T15F	TH2.20
20,0	24,5	48,0	120,0	TH2.0020.B25.48.11.25 R/L	ASVY L ASVX	18,0	9,0	7,0	12,5	2,41	2,9	TH2 M4x12 T15F	T15F	TH2.25
20,0	24,5	48,0	120,0	TH2.0020.B25.48.11.30 R/L	ASVØ L ASVZ	18,0	9,0	7,0	12,5	2,91	3,8	TH2 M4x12 T15F	T15F	TH2.30
20,0	24,5	48,0	120,0	TH2.0020.B25.48.11.40 R/L	ASV2 L ASV1	18,0	9,0	7,0	12,5	3,81	4,9	TH2 M4x12 T15F	T15F	TH2.40
▼ Ød = 25,0 mm														
25,0	27,0	48,0	120,0	TH2.0025.B25.48.12.15 R/L	ASW2 L ASW1	20,5	11,5	7,0	15,0	-	1,9	TH2 M4x12 T15F	T15F	TH2.15
25,0	27,0	48,0	120,0	TH2.0025.B25.48.12.20 R/L	ASW4 L ASW3	20,5	11,5	7,0	15,0	1,91	2,4	TH2 M4x12 T15F	T15F	TH2.20
25,0	27,0	48,0	120,0	TH2.0025.B25.48.12.25 R/L	ASW6 L ASW5	20,5	11,5	7,0	15,0	2,41	2,9	TH2 M4x12 T15F	T15F	TH2.25
25,0	27,0	48,0	120,0	TH2.0025.B25.48.12.30 R/L	ASW8 L ASW7	20,5	11,5	7,0	15,0	2,91	3,8	TH2 M4x12 T15F	T15F	TH2.30
25,0	27,0	48,0	120,0	TH2.0025.B25.48.12.40 R/L	ASXA L ASW9	20,5	11,5	7,0	15,0	3,81	4,9	TH2 M4x12 T15F	T15F	TH2.40
▼ Ød = 25,4 mm														
25,4	27,0	48,0	120,0	TH2.1.000.B25.48.12.15 R/L	AW6Y L AW6X	20,7	11,7	7,0	15,0	-	1,9	TH2 M4x12 T15F	T15F	TH2.15
25,4	27,0	48,0	120,0	TH2.1.000.B25.48.12.20 R/L	AW6Ø L AW6Z	20,7	11,7	7,0	15,0	1,91	2,4	TH2 M4x12 T15F	T15F	TH2.20
25,4	27,0	48,0	120,0	TH2.1.000.B25.48.12.25 R/L	AW62 L AW61	20,7	11,7	7,0	15,0	2,41	2,9	TH2 M4x12 T15F	T15F	TH2.25
25,4	27,0	48,0	120,0	TH2.1.000.B25.48.12.30 R/L	AW64 L AW63	20,7	11,7	7,0	15,0	2,91	3,8	TH2 M4x12 T15F	T15F	TH2.30
25,4	27,0	48,0	120,0	TH2.1.000.B25.48.12.40 R/L	AW66 L AW65	20,7	11,7	7,0	15,0	3,81	4,9	TH2 M4x12 T15F	T15F	TH2.40

Verwandte Werkzeuge finden Sie auch auf der folgenden Seite!
Related Items can be found on the following page as well!

Fortgesetzte Tabelle
Continued Table

Bestellbeispiel // Order example: TH2.0020.B25.48.11.20 R (R = Rechte Ausführung // Right hand version)

Klemmhalter, Innen, Typ B

Klemmhalter für die Innenbearbeitung ab Bohrungsdurchmesser 31,0 mm. Ohne innere Kühlmittelzufuhr.

Toolholder, Internal, Type B

Toolholder for internal applications as of bore diameter 31,0 mm. Without through coolant.

Anzugsmoment (Schraube) // Tightening torque (screw)

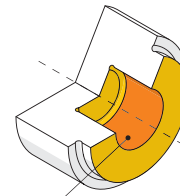
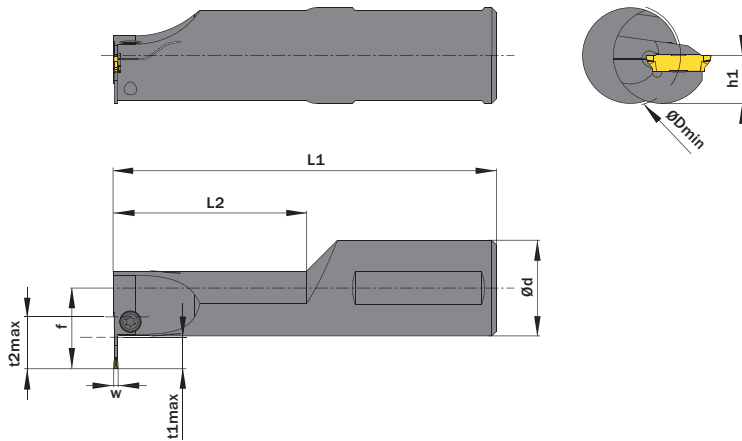
- TH2.15: 1,5 Nm
- TH2.20: 2,0 Nm
- TH2.25: 2,5 Nm
- TH2.30: 3,0 Nm
- TH2.40: 3,0 Nm



TW **ST** **R** Legende Legend **250**

Scan QR-Code Oder besuchen Sie // Or Visit www.simtek.info/cp/859

Für größere Bohrungen
For bigger bores



- Hauptsächlich geeignet für diese Flächen
Mainly designed for these surfaces
- Je nach Schneidplatte ebenfalls möglich
Also possible depending on insert type

Abbildung zeigt / Drawing shows: TH2.0032.B31.61.12.15 R

Ød ^{g6}	ØDmin (Min. Bohrung) / ØDmin (min. bore)	L2	L1	Artikelnummer / Part number	Webcode www.simtek.com/webcode	f	h1 ^{js14}	t1max	t2max	w ≥	w ≤	Schraube / Screw	Schraubenschlüssel / Screw driver	Connectcode www.simtek.com/code
------------------	--	----	----	-----------------------------	---	---	--------------------	-------	-------	-----	-----	------------------	-----------------------------------	---

Fortgesetzte Tabelle / Continued Table **Verwandte Werkzeuge finden Sie auch auf der vorhergehenden Seite!**
Related items can be found on the previous page as well!

▼ Ød = 25,0 mm														
25,0	31,0	61,0	120,0	TH2.0025.B31.61.12.15 R/L	R ASXC L ASXB	23,5	11,5	10,0	16,5	-	1,9	TH2 M4x12 T15F	T15F	TH2.15
25,0	31,0	61,0	120,0	TH2.0025.B31.61.12.20 R/L	R ASXE L ASXD	23,5	11,5	10,0	16,5	1,91	2,4	TH2 M4x12 T15F	T15F	TH2.20
25,0	31,0	61,0	120,0	TH2.0025.B31.61.12.25 R/L	R ASXG L ASXF	23,5	11,5	10,0	16,5	2,41	2,9	TH2 M4x12 T15F	T15F	TH2.25
25,0	31,0	61,0	120,0	TH2.0025.B31.61.12.30 R/L	R ASXJ L ASXH	23,5	11,5	10,0	16,5	2,91	3,8	TH2 M4x12 T15F	T15F	TH2.30
25,0	31,0	61,0	120,0	TH2.0025.B31.61.12.40 R/L	R ASXM L ASXK	23,5	11,5	10,0	16,5	3,81	4,9	TH2 M4x12 T15F	T15F	TH2.40
▼ Ød = 25,4 mm														
25,4	31,0	61,0	120,0	TH2.1.000.B31.61.12.15 R/L	R AW68 L AW67	23,7	11,7	10,0	16,5	-	1,9	TH2 M4x12 T15F	T15F	TH2.15 <small>Inch</small>
25,4	31,0	61,0	120,0	TH2.1.000.B31.61.12.20 R/L	R AW7A L AW69	23,7	11,7	10,0	16,5	1,91	2,4	TH2 M4x12 T15F	T15F	TH2.20 <small>Inch</small>
25,4	31,0	61,0	120,0	TH2.1.000.B31.61.12.25 R/L	R AW7C L AW7B	23,7	11,7	10,0	16,5	2,41	2,9	TH2 M4x12 T15F	T15F	TH2.25 <small>Inch</small>
25,4	31,0	61,0	120,0	TH2.1.000.B31.61.12.30 R/L	R AW7E L AW7D	23,7	11,7	10,0	16,5	2,91	3,8	TH2 M4x12 T15F	T15F	TH2.30 <small>Inch</small>
25,4	31,0	61,0	120,0	TH2.1.000.B31.61.12.40 R/L	R AW7G L AW7F	23,7	11,7	10,0	16,5	3,81	4,9	TH2 M4x12 T15F	T15F	TH2.40 <small>Inch</small>
▼ Ød = 32,0 mm														
32,0	34,0	61,0	120,0	TH2.0032.B31.61.12.15 R/L	R ASYM L ASYK	27,0	15,0	10,0	16,5	-	1,9	TH2 M5x12 T20F	T20F	TH2.15
32,0	34,0	61,0	120,0	TH2.0032.B31.61.12.20 R/L	R ASYP L ASYN	27,0	15,0	10,0	16,5	1,91	2,4	TH2 M5x12 T20F	T20F	TH2.20
32,0	34,0	61,0	120,0	TH2.0032.B31.61.12.25 R/L	R ASYS L ASYQ	27,0	15,0	10,0	16,5	2,41	2,9	TH2 M5x12 T20F	T20F	TH2.25
32,0	34,0	61,0	120,0	TH2.0032.B31.61.12.30 R/L	R ASYU L ASYT	27,0	15,0	10,0	16,5	2,91	3,8	TH2 M5x12 T20F	T20F	TH2.30
32,0	34,0	61,0	120,0	TH2.0032.B31.61.12.40 R/L	R ASYW L ASYV	27,0	15,0	10,0	16,5	3,81	4,9	TH2 M5x12 T20F	T20F	TH2.40

Bestellbeispiel // Order example: TH2.0025.B31.61.12.30 R (R = Rechte Ausführung // Right hand version)

simturn AX
simturn DX
simturn PX
simturn H2
simturn K2
simturn C4
simturn GX
simturn E3
simturn E12
simturn FX
simturn Decolletage
simturn OA
Index

Klemmhalter, Außen, Typ A

Klemmhalter für die Kleinteilebearbeitung. Aufnahme 10,0 x 10,0 mm.

Toolholder, External, Type A

Toolholder for small part machining. Shank size 10,0 x 10,0 mm.

Anzugsmoment (Schraube) // Tightening torque (screw)

TH2.15: 1,5 Nm
TH2.20: 2,0 Nm
TH2.25: 2,5 Nm
TH2.30: 3,0 Nm
TH2.40: 3,0 Nm

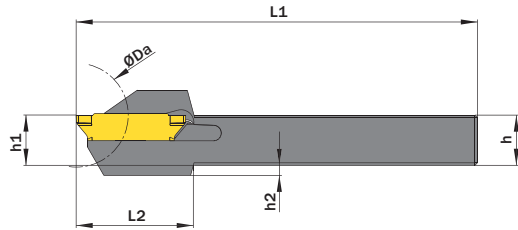


Legende
Legend **250**

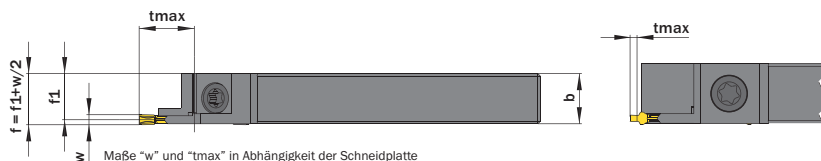


Scan
QR-Code

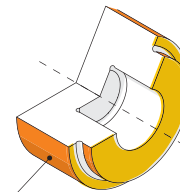
Oder besuchen Sie // Or Visit
www.simtek.info/cp/468



ØDa	tmax
Ø16,0 mm / Ø0.6299"	11,0 mm / 0.4331"
Ø20,0 mm / Ø0.7874"	8,0 mm / 0.3150"
Ø30,0 mm / Ø1.1811"	6,0 mm / 0.2362"
Ø40,0 mm / Ø1.5748"	5,0 mm / 0.1969"
Ø90,0 mm / Ø3.5433"	4,0 mm / 0.1575"
Ø150,0 mm / Ø5.9055"	3,5 mm / 0.1378"



Maße "w" und "tmax" in Abhängigkeit der Schneidplatte
Dimensions "w" and "tmax" depend on cutting insert



- Hauptsächlich geeignet für diese Flächen
Mainly designed for these surfaces
- Je nach Schneidplatte/Aufnahme ebenfalls möglich
Also possible depending on insert/fixation type

Abbildung zeigt / Drawing shows: TH2.1010.A11.08.20 R

h	b	L1	Artikelnummer Part number	Webcode www.simtek.com/webcode	f1	h1 ^{is14}	h2	L2	w ≥	w ≤	Schraube Screw	Schraubenschlüssel Screw driver	Connectcode www.simtek.com/code		
														mm	mm
▼ L1 = 80,0 mm															
10,0	10,0	80,0	TH2.1010.A11.08.15 R/L	R ASNK L ASNJ	9,45	10,0	2,0	28,5	-	1,9	TH2 M4x16,6 T15F	T15F	TH2.15	upd	
10,0	10,0	80,0	TH2.1010.A11.08.20 R/L	R ASDH L ASNM	9,2	10,0	2,0	28,5	1,91	2,4	TH2 M4x16,6 T15F	T15F	TH2.20	upd	
10,0	10,0	80,0	TH2.1010.A11.08.25 R/L	R ASNP L ASNN	8,95	10,0	2,0	28,5	2,41	2,9	TH2 M4x16,6 T15F	T15F	TH2.25	upd	
10,0	10,0	80,0	TH2.1010.A11.08.30 R/L	R ASNS L ASNQ	8,7	10,0	2,0	28,5	2,91	3,8	TH2 M4x16,6 T15F	T15F	TH2.30	upd	
▼ L1 = 125,0 mm															
10,0	10,0	125,0	TH2.1010.A11.12.15 R/L	R AUHH L AUHG	9,45	10,0	2,0	28,5	-	1,9	TH2 M4x16,6 T15F	T15F	TH2.15	upd	
10,0	10,0	125,0	TH2.1010.A11.12.20 R/L	R AUHK L AUHJ	9,2	10,0	2,0	28,5	1,91	2,4	TH2 M4x16,6 T15F	T15F	TH2.20	upd	
10,0	10,0	125,0	TH2.1010.A11.12.25 R/L	R AUHN L AUHM	8,95	10,0	2,0	28,5	2,41	2,9	TH2 M4x16,6 T15F	T15F	TH2.25	upd	
10,0	10,0	125,0	TH2.1010.A11.12.30 R/L	R AUHQ L AUHP	8,7	10,0	2,0	28,5	2,91	3,8	TH2 M4x16,6 T15F	T15F	TH2.30	upd	

Verwandte Werkzeuge finden Sie auch auf der folgenden Seite!
Related Items can be found on the following page as well!

Fortgesetzte Tabelle
Continued Table

Bestellbeispiel // Order example: **TH2.1010.A11.08.20 R** (R = Rechte Ausführung // Right hand version)

Klemmhalter, Außen, Typ A

Klemmhalter für die Kleinteilebearbeitung. Aufnahme 12,0 x 12,0 mm.

Toolholder, External, Type A

Toolholder for small part machining. Shank size 12,0 x 12,0 mm.

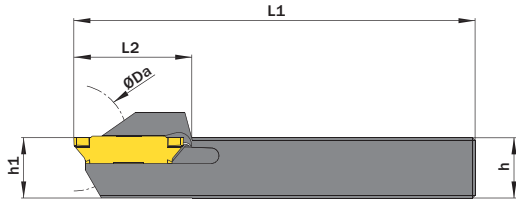
Anzugsmoment (Schraube) // Tightening torque (screw)

- TH2.15: 1,5 Nm
- TH2.20: 2,0 Nm
- TH2.25: 2,5 Nm
- TH2.30: 3,0 Nm
- TH2.40: 3,0 Nm

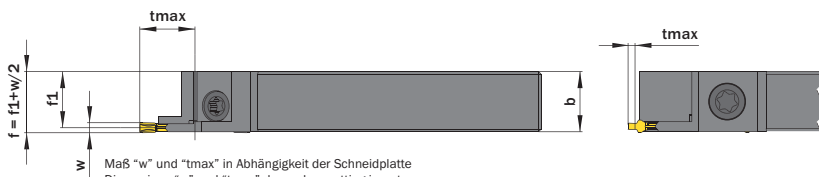


TW **ST** **R** Legende Legend **250**

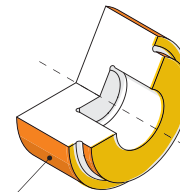
Scan QR-Code Oder besuchen Sie // Or Visit www.simtek.info/cp/469



ØDa	tmax
Ø24,0 mm / Ø0.9449"	13,0 mm / 0.5118"
Ø30,0 mm / Ø1.1811"	10,0 mm / 0.3937"
Ø44,0 mm / Ø1.7323"	8,0 mm / 0.3150"
Ø62,0 mm / Ø2.4409"	7,0 mm / 0.2756"
Ø110,0 mm / Ø4.3307"	6,0 mm / 0.2362"
Ø200,0 mm / Ø7.8740"	5,5 mm / 0.2165"



Maß "w" und "tmax" in Abhängigkeit der Schneidplatte
Dimensions "w" and "tmax" depend on cutting insert



- Hauptsächlich geeignet für diese Flächen
Mainly designed for these surfaces
- Je nach Schneidplatte/Aufnahme ebenfalls möglich
Also possible depending on insert/fixation type

Abbildung zeigt / Drawing shows: TH2.1212.A13.08.20 R

h	b	L1	Artikelnummer Part number	Webcode www.simtek.com/webcode	f1	h1 ^{s14}	L2	w ≥	w ≤	Schraube Screw	Schraubenschlüssel Screw driver	Connectcode www.simtek.com/code
mm	mm	mm			mm	mm	mm	mm	mm			

Fortgesetzte Tabelle
Continued Table

Verwandte Werkzeuge finden Sie auch auf der vorhergehenden Seite!
Related items can be found on the previous page as well!

▼ L1 = 80,0 mm

12,0	12,0	80,0	TH2.1212.A13.08.15 R/L	R ASN6 L ASN5	11,42	12,0	28,5	-	1,9	TH2 M4x16,6 T15F	T15F	TH2.15
12,0	12,0	80,0	TH2.1212.A13.08.20 R/L	R ASN8 L ASN7	11,2	12,0	28,5	1,91	2,4	TH2 M4x16,6 T15F	T15F	TH2.20
12,0	12,0	80,0	TH2.1212.A13.08.25 R/L	R ASPA L ASN9	10,95	12,0	28,5	2,41	2,9	TH2 M4x16,6 T15F	T15F	TH2.25
12,0	12,0	80,0	TH2.1212.A13.08.30 R/L	R ASPC L ASPB	10,67	12,0	28,5	2,91	3,8	TH2 M4x16,6 T15F	T15F	TH2.30
12,0	12,0	80,0	TH2.1212.A13.08.40 R/L	R ASPD L ASPD	10,25	12,0	28,5	3,81	4,9	TH2 M4x12 T15F	T15F	TH2.40

▼ L1 = 125,0 mm

12,7	12,7	125,0	TH2.0.500.S.A13.12.15 R/L	R A1FC L A1FB	12,12	12,7	28,5	-	1,9	TH2 M4x16,6 T15F	T15F	TH2.15	Inch
12,7	12,7	125,0	TH2.0.500.S.A13.12.20 R/L	R A1FE L A1FD	11,9	12,7	28,5	1,91	2,4	TH2 M4x16,6 T15F	T15F	TH2.20	Inch
12,7	12,7	125,0	TH2.0.500.S.A13.12.25 R/L	R A2FN L A1FF	11,65	12,7	28,5	2,41	2,9	TH2 M4x16,6 T15F	T15F	TH2.25	Inch
12,7	12,7	125,0	TH2.0.500.S.A13.12.30 R/L	R A1FH L A1FG	11,38	12,7	28,5	2,91	3,8	TH2 M4x16,6 T15F	T15F	TH2.30	Inch
12,7	12,7	125,0	TH2.0.500.S.A13.12.40 R/L	R A1FM L A1FK	10,95	12,7	28,5	3,81	4,9	TH2 M4x16,6 T15F	T15F	TH2.40	Inch
12,0	12,0	125,0	TH2.1212.A13.12.15 R/L	R AUHT L AUHS	11,42	12,0	28,5	-	1,9	TH2 M4x16,6 T15F	T15F	TH2.15	
12,0	12,0	125,0	TH2.1212.A13.12.20 R/L	R AUHV L AUHU	11,2	12,0	28,5	1,91	2,4	TH2 M4x16,6 T15F	T15F	TH2.20	
12,0	12,0	125,0	TH2.1212.A13.12.25 R/L	R AUHX L AUHW	10,95	12,0	28,5	2,41	2,9	TH2 M4x16,6 T15F	T15F	TH2.25	
12,0	12,0	125,0	TH2.1212.A13.12.30 R/L	R AUHZ L AUHY	10,67	12,0	28,5	2,91	3,8	TH2 M4x16,6 T15F	T15F	TH2.30	
12,0	12,0	125,0	TH2.1212.A13.12.40 R/L	R AUH1 L AUH0	10,25	12,0	28,5	3,81	4,9	TH2 M4x16,6 T15F	T15F	TH2.40	

Bestellbeispiel // Order example: TH2.1212.A13.12.15 R (R = Rechte Ausführung // Right hand version)

Klemmhalter, Außen, Typ B

Klemmhalter für die Außenbearbeitung.
Auf maximale Stechtiefe ausgelegt.

Toolholder, External, Type B

Toolholder for external applications.
Designed for highest cutting depths.

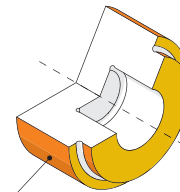
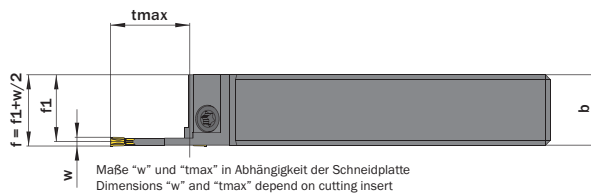
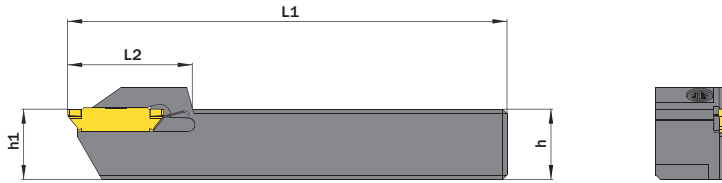
Anzugsmoment (Schraube) // Tightening torque (screw)

- TH2.15: 1,5 Nm
- TH2.20: 2,0 Nm
- TH2.25: 2,5 Nm
- TH2.30: 3,0 Nm
- TH2.40: 3,0 Nm



TW **ST** **R** Legende Legend 250

Scan QR-Code Oder besuchen Sie // Or Visit www.simtek.info/cp/861



- Hauptsächlich geeignet für diese Flächen
Mainly designed for these surfaces
- Je nach Schneidplatte/Aufnahme ebenfalls möglich
Also possible depending on insert/fixation type

Abbildung zeigt / Drawing shows: TH2.1616.B18.12.20 R

h	b	tmax	L1	Artikelnummer Part number	Webcode www.simtek.com/webcode	f1	h1 ^{js14}	L2	w ≥	w ≤	Schraube Screw	Schraubenschlüssel Screw driver	Connectcode www.simtek.com/code	
mm	mm	mm	mm			mm	mm	mm	mm	mm				
▼ h = 15,875 mm														
15,875	15,875	18,0	125,0	TH2.0.625.S.B18.12.15 R/L	R A1FP L A1FN	15,3	15,88	28,5	-	1,9	TH2 M4x16,6 T15F	T15F	TH2.15	inch
15,875	15,875	18,0	125,0	TH2.0.625.S.B18.12.20 R/L	R A1FS L A1FQ	15,08	15,88	28,5	1,91	2,4	TH2 M4x16,6 T15F	T15F	TH2.20	inch
15,875	15,875	18,0	125,0	TH2.0.625.S.B18.12.25 R/L	R A1FU L A1FT	14,82	15,88	28,5	2,41	2,9	TH2 M4x16,6 T15F	T15F	TH2.25	inch
15,875	15,875	18,0	125,0	TH2.0.625.S.B18.12.30 R/L	R A1FW L A1FV	14,58	15,88	28,5	2,91	3,8	TH2 M4x16,6 T15F	T15F	TH2.30	inch
15,875	15,875	18,0	125,0	TH2.0.625.S.B18.12.40 R/L	R A1FY L A1FX	14,12	15,88	28,5	3,81	4,9	TH2 M4x16,6 T15F	T15F	TH2.40	inch
▼ h = 16,0 mm														
16,0	16,0	18,0	125,0	TH2.1616.B18.12.15 R/L	R ASQE L ASQD	15,42	16,0	28,5	-	1,9	TH2 M4x16,6 T15F	T15F	TH2.15	upd
16,0	16,0	18,0	125,0	TH2.1616.B18.12.20 R/L	R ASQG L ASQF	15,2	16,0	28,5	1,91	2,4	TH2 M4x16,6 T15F	T15F	TH2.20	
16,0	16,0	18,0	125,0	TH2.1616.B18.12.25 R/L	R ASQJ L ASQH	14,95	16,0	28,5	2,41	2,9	TH2 M4x16,6 T15F	T15F	TH2.25	
16,0	16,0	18,0	125,0	TH2.1616.B18.12.30 R/L	R ASQM L ASQK	14,7	16,0	28,5	2,91	3,8	TH2 M4x16,6 T15F	T15F	TH2.30	
16,0	16,0	18,0	125,0	TH2.1616.B18.12.40 R/L	R ASQP L ASQN	14,25	16,0	28,5	3,81	4,9	TH2 M4x16,6 T15F	T15F	TH2.40	upd
▼ h = 19,05 mm														
19,05	19,05	18,0	125,0	TH2.0.750.S.B18.12.15 R/L	R AW7P L AW8M	18,48	19,05	28,5	-	1,9	TH2 M4x16,6 T15F	T15F	TH2.15	upd
19,05	19,05	18,0	125,0	TH2.0.750.S.B18.12.20 R/L	R AW7Q L AW8N	18,25	19,05	28,5	1,91	2,4	TH2 M4x16,6 T15F	T15F	TH2.20	inch
19,05	19,05	18,0	125,0	TH2.0.750.S.B18.12.25 R/L	R AW7S L AW8P	18,0	19,05	28,5	2,41	2,9	TH2 M4x16,6 T15F	T15F	TH2.25	inch
19,05	19,05	18,0	125,0	TH2.0.750.S.B18.12.30 R/L	R AW7T L AW8Q	17,75	19,05	28,5	2,91	3,8	TH2 M4x16,6 T15F	T15F	TH2.30	inch
19,05	19,05	18,0	125,0	TH2.0.750.S.B18.12.40 R/L	R AW7U L AW8S	17,3	19,05	28,5	3,81	4,9	TH2 M4x16,6 T15F	T15F	TH2.40	upd
▼ h = 20,0 mm														
20,0	20,0	18,0	125,0	TH2.2020.B18.12.15 R/L	R ASSP L ASSN	19,42	20,0	28,5	-	1,9	TH2 M4x16,6 T15F	T15F	TH2.15	upd
20,0	20,0	18,0	125,0	TH2.2020.B18.12.20 R/L	R ASSS L ASSQ	19,2	20,0	28,5	1,91	2,4	TH2 M4x16,6 T15F	T15F	TH2.20	
20,0	20,0	18,0	125,0	TH2.2020.B18.12.25 R/L	R ASSU L ASST	18,95	20,0	28,5	2,41	2,9	TH2 M4x16,6 T15F	T15F	TH2.25	
20,0	20,0	18,0	125,0	TH2.2020.B18.12.30 R/L	R ASSW L ASSV	18,7	20,0	28,5	2,91	3,8	TH2 M4x16,6 T15F	T15F	TH2.30	
20,0	20,0	18,0	125,0	TH2.2020.B18.12.40 R/L	R ASSY L ASSX	18,25	20,0	28,5	3,81	4,9	TH2 M4x16,6 T15F	T15F	TH2.40	upd

Verwandte Werkzeuge finden Sie auch auf der folgenden Seite!
Related Items can be found on the following page as well!

Fortgesetzte Tabelle
Continued Table

Bestellbeispiel // Order example: TH2.1616.B18.12.30 R (R = Rechte Ausführung // Right hand version)

Klemmhalter, Außen, Typ B

Klemmhalter für die Außenbearbeitung.
Auf maximale Stechtiefe ausgelegt.

Toolholder, External, Type B

Toolholder for external applications.
Designed for highest cutting depths.

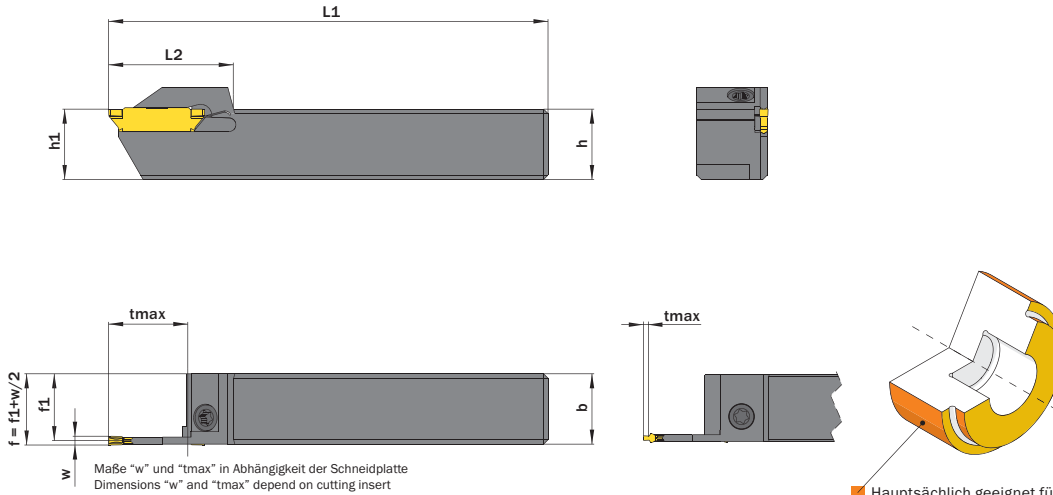
Anzugsmoment (Schraube) // Tightening torque (screw)

- TH2.15: 1,5 Nm
- TH2.20: 2,0 Nm
- TH2.25: 2,5 Nm
- TH2.30: 3,0 Nm
- TH2.40: 3,0 Nm



TW **ST** **R** Legende **250**
Legend

Scan QR-Code Oder besuchen Sie // Or Visit www.simtek.info/cp/1037



- **Hauptsächlich geeignet für diese Flächen**
Mainly designed for these surfaces
- **Je nach Schneidplatte/Aufnahme ebenfalls möglich**
Also possible depending on insert/fixation type

Abbildung zeigt / Drawing shows: TH2.1616.B18.10.20 R

h	b	tmax	L1	Artikelnummer Part number	Webcode www.simtek.com/webcode	f1	h1 ^{js14}	L2	w ≥	w ≤	Schraube Screw	Schraubenschlüssel Screw driver	Connectcode www.simtek.com/ccode
mm	mm	mm	mm			mm	mm	mm	mm	mm			

Fortgesetzte Tabelle
Continued Table

Verwandte Werkzeuge finden Sie auch auf der vorhergehenden Seite!
Related items can be found on the previous page as well!

▼ h = 25,0 mm													
25,0	25,0	18,0	150,0	TH2.2525.B18.15.15 R/L	R ASTY L ASTX	24,45	25,0	28,5	-	1,9	TH2 M4x16,6 T15F	T15F	TH2.15
25,0	25,0	18,0	150,0	TH2.2525.B18.15.20 R/L	R AST0 L ASTZ	24,2	25,0	28,5	1,91	2,4	TH2 M4x16,6 T15F	T15F	TH2.20
25,0	25,0	18,0	150,0	TH2.2525.B18.15.25 R/L	R AST2 L AST1	23,95	25,0	28,5	2,41	2,9	TH2 M4x16,6 T15F	T15F	TH2.25
25,0	25,0	18,0	150,0	TH2.2525.B18.15.30 R/L	R AST4 L AST3	23,7	25,0	28,5	2,91	3,8	TH2 M4x16,6 T15F	T15F	TH2.30
25,0	25,0	18,0	150,0	TH2.2525.B18.15.40 R/L	R AST6 L AST5	23,2	25,0	28,5	3,81	4,9	TH2 M4x16,6 T15F	T15F	TH2.40
▼ h = 25,4 mm													
25,4	25,4	18,0	150,0	TH2.1.000.S.B18.15.15 R/L	R AW7H L AW8F	24,85	25,4	28,5	-	1,9	TH2 M4x16,6 T15F	T15F	TH2.15 Inch
25,4	25,4	18,0	150,0	TH2.1.000.S.B18.15.20 R/L	R AW7J L AW8G	24,6	25,4	28,5	1,91	2,4	TH2 M4x16,6 T15F	T15F	TH2.20 Inch
25,4	25,4	18,0	150,0	TH2.1.000.S.B18.15.25 R/L	R AW7K L AW8H	24,35	25,4	28,5	2,41	2,9	TH2 M4x16,6 T15F	T15F	TH2.25 Inch
25,4	25,4	18,0	150,0	TH2.1.000.S.B18.15.30 R/L	R AW7M L AW8J	24,1	25,4	28,5	2,91	3,8	TH2 M4x16,6 T15F	T15F	TH2.30 Inch
25,4	25,4	18,0	150,0	TH2.1.000.S.B18.15.40 R/L	R AW7N L AW8K	23,6	25,4	28,5	3,81	4,9	TH2 M4x16,6 T15F	T15F	TH2.40 Inch

Bestellbeispiel // Order example: TH2.2525.B18.15.30 R (R = Rechte Ausführung // Right hand version)

simturn AX
simturn DX
simturn PX
simturn H2
simturn K2
simturn C4
simturn GX
simturn E3
simturn E12
simturn FX
simturn Decolletage
simturn OA
Index

Klemmhalter, Außen, Typ C

Klemmhalter für die Außenbearbeitung.
Reduzierte Stechtiefe für höchste Stabilität.

Toolholder, External, Type C

Toolholder for external applications.
Reduced cutting depth, designed for highest stability.

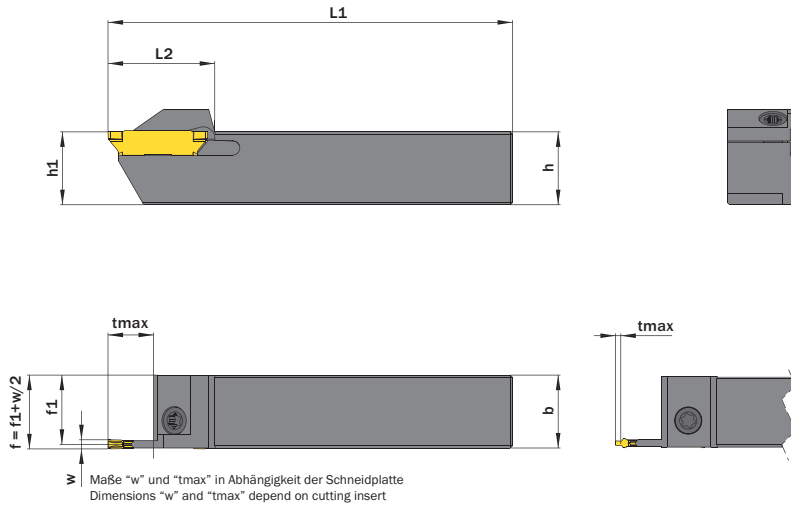
Anzugsmoment (Schraube) // Tightening torque (screw)

- TH2.15: 1,5 Nm
- TH2.20: 2,0 Nm
- TH2.25: 2,5 Nm
- TH2.30: 3,0 Nm
- TH2.40: 3,0 Nm



TW **ST** **R** Legende **250**
Legend

Scan QR-Code Oder besuchen Sie // Or Visit www.simtek.info/cp/862



- Hauptsächlich geeignet für diese Flächen
Mainly designed for these surfaces
- Je nach Schneidplatte/Aufnahme ebenfalls möglich
Also possible depending on insert/fixation type

Abbildung zeigt / Drawing shows: TH2.1616.C10.10.20 R

h	b	tmax	L1	Artikelnummer Part number	Webcode www.simtek.com/webcode	f1	h1 ^{js14}	L2	w ≥	w ≤	Schraube Screw	Schraubenschlüssel Screw driver	Connectcode www.simtek.com/code
mm	mm	mm	mm			mm	mm	mm	mm	mm			
▼ h = 16,0 mm													
16,0	16,0	10,0	125,0	TH2.1616.C10.12.15 R/L	R ASQ2 L ASQ1	15,45	16,0	28,5	-	1,9	TH2 M4x16,6 T15F	T15F	TH2.15
16,0	16,0	10,0	125,0	TH2.1616.C10.12.20 R/L	R ASQ4 L ASQ3	15,2	16,0	28,5	1,91	2,4	TH2 M4x16,6 T15F	T15F	TH2.20
16,0	16,0	10,0	125,0	TH2.1616.C10.12.25 R/L	R ASQ6 L ASQ5	14,95	16,0	28,5	2,41	2,9	TH2 M4x16,6 T15F	T15F	TH2.25
16,0	16,0	10,0	125,0	TH2.1616.C10.12.30 R/L	R ASQ8 L ASQ7	14,68	16,0	28,5	2,91	3,8	TH2 M4x16,6 T15F	T15F	TH2.30
16,0	16,0	10,0	125,0	TH2.1616.C10.12.40 R/L	R ASSA L ASQ9	14,25	16,0	28,5	3,81	4,9	TH2 M4x16,6 T15F	T15F	TH2.40
▼ h = 19,05 mm													
19,05	19,05	10,0	125,0	TH2.0.750.S.C10.12.15 R/L	R AW70 L AW8Y	18,5	19,05	28,5	-	1,9	TH2 M4x16,6 T15F	T15F	TH2.15 Inch
19,05	19,05	10,0	125,0	TH2.0.750.S.C10.12.20 R/L	R AW71 L AW8Z	18,25	19,05	28,5	1,91	2,4	TH2 M4x16,6 T15F	T15F	TH2.20 Inch
19,05	19,05	10,0	125,0	TH2.0.750.S.C10.12.25 R/L	R AW72 L AW80	18,0	19,05	28,5	2,41	2,9	TH2 M4x16,6 T15F	T15F	TH2.25 Inch
19,05	19,05	10,0	125,0	TH2.0.750.S.C10.12.30 R/L	R AW73 L AW81	17,75	19,05	28,5	2,91	3,8	TH2 M4x16,6 T15F	T15F	TH2.30 Inch
19,05	19,05	10,0	125,0	TH2.0.750.S.C10.12.40 R/L	R AW74 L AW82	17,5	19,05	28,5	3,81	4,9	TH2 M4x16,6 T15F	T15F	TH2.40 Inch
▼ h = 20,0 mm													
20,0	20,0	10,0	125,0	TH2.2020.C10.12.15 R/L	R ASTA L ASS9	19,45	20,0	28,5	-	1,9	TH2 M4x16,6 T15F	T15F	TH2.15
20,0	20,0	10,0	125,0	TH2.2020.C10.12.20 R/L	R ASTC L ASTB	19,2	20,0	28,5	1,91	2,4	TH2 M4x16,6 T15F	T15F	TH2.20
20,0	20,0	10,0	125,0	TH2.2020.C10.12.25 R/L	R ASTE L ASTD	18,95	20,0	28,5	2,41	2,9	TH2 M4x16,6 T15F	T15F	TH2.25
20,0	20,0	10,0	125,0	TH2.2020.C10.12.30 R/L	R ASTG L ASTF	18,7	20,0	28,5	2,91	3,8	TH2 M4x16,6 T15F	T15F	TH2.30
20,0	20,0	10,0	125,0	TH2.2020.C10.12.40 R/L	R ASTJ L ASTH	18,2	20,0	28,5	3,81	4,9	TH2 M4x16,6 T15F	T15F	TH2.40

Verwandte Werkzeuge finden Sie auch auf der folgenden Seite!
Related Items can be found on the following page as well!

Fortgesetzte Tabelle
Continued Table

Bestellbeispiel // Order example: TH2.1616.C10.12.30 R (R = Rechte Ausführung // Right hand version)

Klemmhalter, Außen, Typ C

Klemmhalter für die Außenbearbeitung.
Reduzierte Stechtiefe für höchste Stabilität.

Toolholder, External, Type C

Toolholder for external applications.
Reduced cutting depth, designed for highest stability.

Anzugsmoment (Schraube) // Tightening torque (screw)

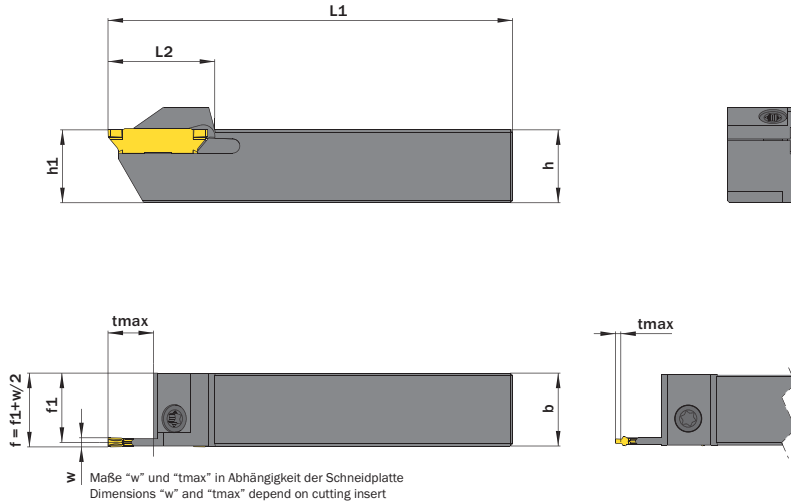
TH2.15: 1,5 Nm
TH2.20: 2,0 Nm
TH2.25: 2,5 Nm
TH2.30: 3,0 Nm
TH2.40: 3,0 Nm



TW
ST
R

Legende
Legend **250**

Scan QR-Code
Oder besuchen Sie // Or Visit
www.simtek.info/cp/1057



- Hauptsächlich geeignet für diese Flächen
Mainly designed for these surfaces
- Je nach Schneidplatte/Aufnahme ebenfalls möglich
Also possible depending on insert/fixation type

Abbildung zeigt / Drawing shows: TH2.1616.C10.10.20 R

h	b	tmax	L1	Artikelnummer Part number	Webcode www.simtek.com/webcode	f1	h1 ^{js14}	L2	w ≥	w ≤	Schraube Screw	Schraubenschlüssel Screw driver	Connectcode www.simtek.com/ccode
mm	mm	mm	mm			mm	mm	mm	mm	mm			

Fortgesetzte Tabelle
Continued Table

Verwandte Werkzeuge finden Sie auch auf der vorhergehenden Seite!
Related items can be found on the previous page as well!

▼ h = 25,0 mm

25,0	25,0	10,0	150,0	TH2.2525.C10.15.15 R/L	R ASUJ L ASUH	24,45	25,0	28,5	-	1,9	TH2 M4x16,6 T15F	T15F	TH2.15
25,0	25,0	10,0	150,0	TH2.2525.C10.15.20 R/L	R ASUM L ASUK	24,2	25,0	28,5	1,91	2,4	TH2 M4x16,6 T15F	T15F	TH2.20
25,0	25,0	10,0	150,0	TH2.2525.C10.15.25 R/L	R ASUP L ASUN	23,95	25,0	28,5	2,41	2,9	TH2 M4x16,6 T15F	T15F	TH2.25
25,0	25,0	10,0	150,0	TH2.2525.C10.15.30 R/L	R ASUS L ASUQ	23,7	25,0	28,5	2,91	3,8	TH2 M4x16,6 T15F	T15F	TH2.30
25,0	25,0	10,0	150,0	TH2.2525.C10.15.40 R/L	R ASUU L ASUT	23,2	25,0	28,5	3,81	4,9	TH2 M4x16,6 T15F	T15F	TH2.40

▼ h = 25,4 mm

25,4	25,4	10,0	150,0	TH2.1.000.S.C10.15.15 R/L	R AW7V L AW8T	24,85	25,4	28,5	-	1,9	TH2 M4x16,6 T15F	T15F	TH2.15	inch
25,4	25,4	10,0	150,0	TH2.1.000.S.C10.15.20 R/L	R AW7W L AW8U	24,6	25,4	28,5	1,91	2,4	TH2 M4x16,6 T15F	T15F	TH2.20	inch
25,4	25,4	10,0	150,0	TH2.1.000.S.C10.15.25 R/L	R AW7X L AW8V	24,35	25,4	28,5	2,41	2,9	TH2 M4x16,6 T15F	T15F	TH2.25	inch
25,4	25,4	10,0	150,0	TH2.1.000.S.C10.15.30 R/L	R AW7Y L AW8W	24,1	25,4	28,5	2,91	3,8	TH2 M4x16,6 T15F	T15F	TH2.30	inch
25,4	25,4	10,0	150,0	TH2.1.000.S.C10.15.40 R/L	R AW7Z L AW8X	23,6	25,4	28,5	3,81	4,9	TH2 M4x16,6 T15F	T15F	TH2.40	inch

Bestellbeispiel // Order example: TH2.2525.C10.15.15 R (R = Rechte Ausführung // Right hand version)

Klemmhalter, Eckenfreistriche außen

Klemmhalter für Eckenfreistriche außen. Geeignet für Vollradiusschneidplatten sowie für passende Individualwerkzeuge.

Toolholder, External Corner Relief

Toolholder for external corner reliefs.
For use with full radius inserts and for suitable customized tools.

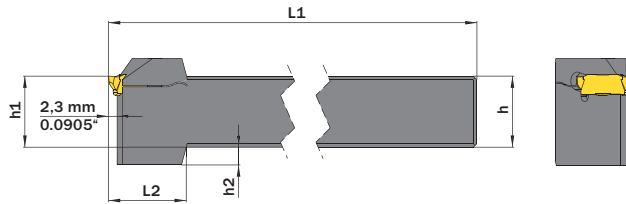
Anzugsmoment (Schraube) // Tightening torque (screw)

- TH2.15: 1,5 Nm
- TH2.20: 2,0 Nm
- TH2.25: 2,5 Nm
- TH2.30: 3,0 Nm
- TH2.40: 3,0 Nm

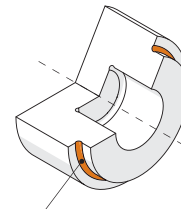
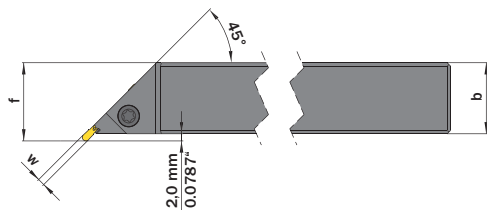


TW **ST** **R** Legende Legend **250**

Scan QR-Code Oder besuchen Sie // Or Visit www.simtek.info/cp/473



Bitte beachten Sie die unten aufgeführten Hinweise.
Please pay attention to the additional information below.



Hauptsächlich geeignet für diese Flächen
Mainly designed for these surfaces

Abbildung zeigt / Drawing shows: TH2.2020.D45.12.20 R

h	b	L1	Artikelnummer Part number	Webcode www.simtek.com/webcode	f	h1 ^{is14}	h2	L2	w ≥	w ≤	Schraube Screw	Schraubenschlüssel Screw driver	Connectcode www.simtek.com/code	Inch
mm	mm	mm			mm	mm	mm	mm	mm	mm				
▼ h = 19,05 mm														
19,05	19,05	125,0	TH2.0.750.S.D45.12.15 R/L	R AW8A L AW88	21,05	19,05	5,0	30,0	-	1,9	TH2 M4x12 T15F	T15F	TH2.15	Inch
19,05	19,05	125,0	TH2.0.750.S.D45.12.20 R/L	R AW8B L AW89	21,05	19,05	5,0	30,0	1,91	2,4	TH2 M4x12 T15F	T15F	TH2.20	Inch
19,05	19,05	125,0	TH2.0.750.S.D45.12.25 R/L	R AW8C L AW9A	21,05	19,05	5,0	30,0	2,41	2,9	TH2 M4x12 T15F	T15F	TH2.25	Inch
19,05	19,05	125,0	TH2.0.750.S.D45.12.30 R/L	R AW8D L AW9B	21,05	19,05	5,0	30,0	2,91	3,8	TH2 M4x12 T15F	T15F	TH2.30	Inch
19,05	19,05	125,0	TH2.0.750.S.D45.12.40 R/L	R AW8E L AW9C	21,05	19,05	5,0	30,0	3,81	4,9	TH2 M4x12 T15F	T15F	TH2.40	Inch
▼ h = 20,0 mm														
20,0	20,0	125,0	TH2.2020.D45.12.15 R/L	R ASUW L ASUV	22,0	20,0	5,0	30,0	-	1,9	TH2 M4x16,6 T15F	T15F	TH2.15	
20,0	20,0	125,0	TH2.2020.D45.12.20 R/L	R ASUY L ASUX	22,0	20,0	5,0	30,0	1,91	2,4	TH2 M4x16,6 T15F	T15F	TH2.20	
20,0	20,0	125,0	TH2.2020.D45.12.25 R/L	R ASU0 L ASUZ	22,0	20,0	5,0	30,0	2,41	2,9	TH2 M4x16,6 T15F	T15F	TH2.25	
20,0	20,0	125,0	TH2.2020.D45.12.30 R/L	R ASU2 L ASU1	22,0	20,0	5,0	30,0	2,91	3,8	TH2 M4x16,6 T15F	T15F	TH2.30	
20,0	20,0	125,0	TH2.2020.D45.12.40 R/L	R ASU4 L ASU3	22,0	20,0	5,0	30,0	3,81	4,9	TH2 M4x16,6 T15F	T15F	TH2.40	

Verwandte Werkzeuge finden Sie auch auf der folgenden Seite!
Related Items can be found on the following page as well!

Fortgesetzte Tabelle
Continued Table

Bestellbeispiel // Order example: **TH2.2020.D45.12.15 R** (R = Rechte Ausführung // Right hand version)

Bitte stimmen Sie die technische Machbarkeit des von Ihnen gewünschten Außenfreistrichs mit unserer technischen Fachberatung ab:
+49 7473 9517-140 oder support@simtek.com

Please contact our technical department in order to proof the technical feasibility of the corner relief you are planning to machine:
+49 7473 9517-140 or support@simtek.com

Bei einer Bestellung senden Sie uns bitte eine Werkstückzeichnung.

In case of an order, we kindly ask you to send us a drawing of the workpiece.

Klemmhalter, Eckenfreistriche außen

Klemmhalter für Eckenfreistriche außen. Geeignet für Vollradiusschneidplatten sowie für passende Individualwerkzeuge.

Toolholder, External Corner Relief

Toolholder for external corner reliefs.
For use with full radius inserts and for suitable customized tools.

Anzugsmoment (Schraube) // Tightening torque (screw)

TH2.15: 1,5 Nm
TH2.20: 2,0 Nm
TH2.25: 2,5 Nm
TH2.30: 3,0 Nm
TH2.40: 3,0 Nm



TW
ST

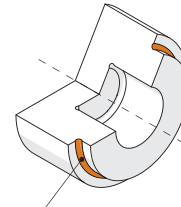
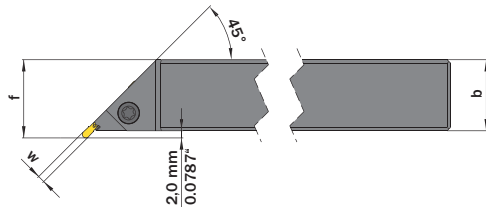
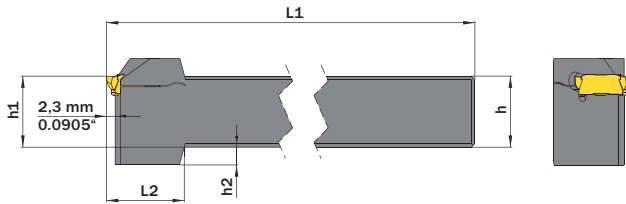
R

Legende
Legend 250



Scan
QR-Code

Oder besuchen Sie // Or Visit
www.simtek.info/cp/1058



Hauptsächlich geeignet für diese Flächen
Mainly designed for these surfaces

Bitte beachten Sie die unten aufgeführten Hinweise.
Please pay attention to the additional information below.

Abbildung zeigt / Drawing shows: TH2.2020.D45.12.20 R

h	b	L1	Artikelnummer Part number	Webcode www.simtek.com/webcode	f	h1 ^{is14}	h2	L2	w ≥	w ≤	Schraube Screw	Schraubenschlüssel Screw driver	Connectcode www.simtek.com/ccode
mm	mm	mm			mm	mm	mm	mm	mm	mm			

Fortgesetzte Tabelle
Continued Table

Verwandte Werkzeuge finden Sie auch auf der vorhergehenden Seite!
Related items can be found on the previous page as well!

▼ h = 25,0 mm

25,0	25,0	150,0	TH2.2525.D45.15.15 R/L	R ASU6 L ASU5	27,0	25,0	-	-	-	1,9	TH2 M4x16,6 T15F	T15F	TH2.15
25,0	25,0	150,0	TH2.2525.D45.15.20 R/L	R ASU8 L ASU7	27,0	25,0	-	-	1,91	2,4	TH2 M4x16,6 T15F	T15F	TH2.20
25,0	25,0	150,0	TH2.2525.D45.15.25 R/L	R ASVA L ASU9	27,0	25,0	-	-	2,41	2,9	TH2 M4x16,6 T15F	T15F	TH2.25
25,0	25,0	150,0	TH2.2525.D45.15.30 R/L	R ASVC L ASVB	27,0	25,0	-	-	2,91	3,8	TH2 M4x16,6 T15F	T15F	TH2.30
25,0	25,0	150,0	TH2.2525.D45.15.40 R/L	R ASVE L ASVD	27,0	25,0	-	-	3,81	4,9	TH2 M4x16,6 T15F	T15F	TH2.40

▼ h = 25,4 mm

25,4	25,4	150,0	TH2.1.000.S.D45.15.15 R/L	R AW75 L AW83	27,4	25,4	-	-	-	1,9	TH2 M4x16,6 T15F	T15F	TH2.15	Inch
25,4	25,4	150,0	TH2.1.000.S.D45.15.20 R/L	R AW76 L AW84	27,4	25,4	-	-	1,91	2,4	TH2 M4x16,6 T15F	T15F	TH2.20	Inch
25,4	25,4	150,0	TH2.1.000.S.D45.15.25 R/L	R AW77 L AW85	27,4	25,4	-	-	2,41	2,9	TH2 M4x16,6 T15F	T15F	TH2.25	Inch
25,4	25,4	150,0	TH2.1.000.S.D45.15.30 R/L	R AW78 L AW86	27,4	25,4	-	-	2,91	3,8	TH2 M4x16,6 T15F	T15F	TH2.30	Inch
25,4	25,4	150,0	TH2.1.000.S.D45.15.40 R/L	R AW79 L AW87	27,4	25,4	-	-	3,81	4,9	TH2 M4x16,6 T15F	T15F	TH2.40	Inch

Bestellbeispiel // Order example: TH2.2525.D45.15.15 R (R = Rechte Ausführung // Right hand version)

Bitte stimmen Sie die technische Machbarkeit des von Ihnen gewünschten Außenfreistrichs mit unserer technischen Fachberatung ab:
+49 7473 9517-140 oder support@simtek.com

Please contact our technical department in order to proof the technical feasibility of the corner relief you are planning to machine:
+49 7473 9517-140 or support@simtek.com

Bei einer Bestellung senden Sie uns bitte eine Werkstückzeichnung.
In case of an order, we kindly ask you to send us a drawing of the workpiece.

Klemmhalter, Eckenfreistriche innen

Klemmhalter für Eckenfreistriche innen. Geeignet für Vollradiusschneidplatten sowie für passende Individualwerkzeuge.

Toolholder, Internal Corner Relief

Toolholder for internal corner reliefs.
For use with full radius inserts and for suitable customized tools.

Anzugsmoment (Schraube) // Tightening torque (screw)

TH2.15: 1,5 Nm
TH2.20: 2,0 Nm
TH2.25: 2,5 Nm
TH2.30: 3,0 Nm
TH2.40: 3,0 Nm



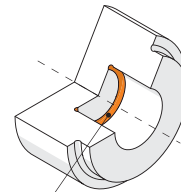
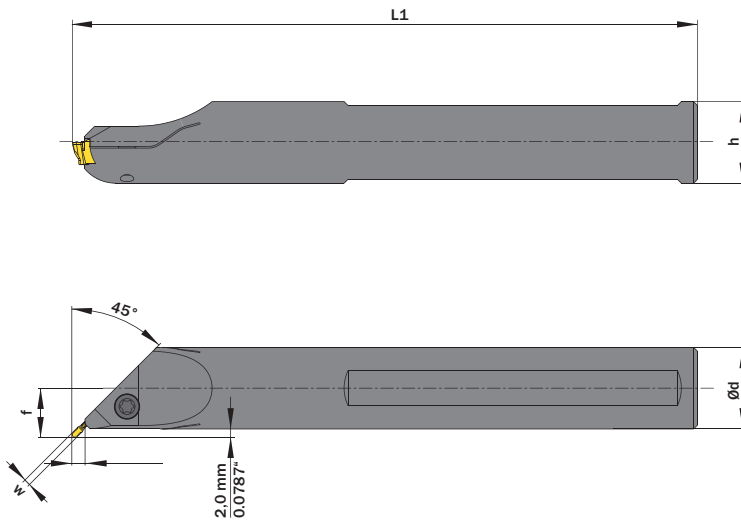
Legende
Legend **250**



Scan
QR-Code

Oder besuchen Sie // Or Visit
www.simtek.info/cp/480

Bitte beachten Sie die unten
aufgeführten Hinweise.
Please pay attention to the
additional information below.



Hauptsächlich geeignet für diese Flächen
Mainly designed for these surfaces

Abbildung zeigt / Drawing shows: TH2.0020.D45.60.18.15 R

Ød ^{g6} mm	Artikelnummer Part number	Webcode www.simtek.com/webcode	f mm	h mm	h1 mm	L1 ^{js14} mm	w ≥ mm	w ≤ mm	Schraube Screw	Schraubenschlüssel Screw driver	Connectcode www.simtek.com/code			
												R	L	
▼ Ød = 20,0 mm														
20,0	TH2.0020.D45.60.18.15 R/L	ASV4	ASV3	12,0	18,0	9,0	180,0	-	1,9	TH2 M4x12 T15F	T15F	TH2.15		
20,0	TH2.0020.D45.60.18.20 R/L	ASV6	ASV5	12,0	18,0	9,0	180,0	1,91	2,4	TH2 M4x12 T15F	T15F	TH2.20		
20,0	TH2.0020.D45.60.18.25 R/L	ASV8	ASV7	12,0	18,0	9,0	180,0	2,41	2,9	TH2 M4x12 T15F	T15F	TH2.25		
20,0	TH2.0020.D45.60.18.30 R/L	ASWA	ASV9	12,0	18,0	9,0	180,0	2,91	3,8	TH2 M4x12 T15F	T15F	TH2.30		
20,0	TH2.0020.D45.60.18.40 R/L	ASWC	ASWB	12,0	18,0	9,0	180,0	3,81	4,9	TH2 M4x12 T15F	T15F	TH2.40		
▼ Ød = 31,75 mm														
31,75	TH2.1.250.D45.80.25.15 R	A4T5		17,9	29,8	14,9	250,0	-	1,9	TH2 M4x12 T15F	T15F	TH2.15	new	inch
31,75	TH2.1.250.D45.80.25.20 R	A6W1		17,9	29,8	14,9	250,0	1,91	2,4	TH2 M4x12 T15F	T15F	TH2.20	new	inch
31,75	TH2.1.250.D45.80.25.25 R	A6W3		17,9	29,8	14,9	250,0	2,41	2,9	TH2 M4x12 T15F	T15F	TH2.25	new	inch
31,75	TH2.1.250.D45.80.25.30 R	A6UN		17,9	29,8	14,9	250,0	2,91	3,8	TH2 M4x12 T15F	T15F	TH2.30	new	inch
31,75	TH2.1.250.D45.80.25.40 R	A6W5		17,9	29,8	14,9	250,0	3,81	4,9	TH2 M4x12 T15F	T15F	TH2.40	new	inch
▼ Ød = 32,0 mm														
32,0	TH2.0032.D45.80.25.15 R/L	ASY4	ASYX	18,0	30,0	15,0	250,0	-	1,9	TH2 M4x12 T15F	T15F	TH2.15		
32,0	TH2.0032.D45.80.25.20 R/L	ASY0	ASYZ	18,0	30,0	15,0	250,0	1,91	2,4	TH2 M4x12 T15F	T15F	TH2.20		
32,0	TH2.0032.D45.80.25.25 R/L	ASY2	ASY1	18,0	30,0	15,0	250,0	2,41	2,9	TH2 M4x12 T15F	T15F	TH2.25		
32,0	TH2.0032.D45.80.25.30 R/L	ASY4	ASY3	18,0	30,0	15,0	250,0	2,91	3,8	TH2 M4x12 T15F	T15F	TH2.30		
32,0	TH2.0032.D45.80.25.40 R/L	ASY6	ASY5	18,0	30,0	15,0	250,0	3,81	4,9	TH2 M4x12 T15F	T15F	TH2.40		

Bestellbeispiel // Order example: TH2.0020.D45.60.18.15 R (R = Rechte Ausführung // Right hand version)

Bitte stimmen Sie die technische Machbarkeit des von Ihnen gewünschten Außenfreistrichs mit unserer technischen Fachberatung ab:

+49 7473 9517-140 oder support@simtek.com

Please contact our technical department in order to proof the technical feasibility of the corner relief you are planning to machine:

+49 7473 9517-140 or support@simtek.com

Bei einer Bestellung senden Sie uns bitte eine Werkstückzeichnung.

In case of an order, we kindly ask you to send us a drawing of the workpiece.

Kassette für Modulares Werkzeugsystem TOA

Geeignet für SIMTEK Grundhalter mit Polygonschaft nach ISO 26623.

Cassette for Modular Tool System TOA

For use on SIMTEK base toolholder with polygon shank according to ISO 26623.

Anzugsmoment (Schraube) // Tightening torque (screw)

TH2.15: 1,5 Nm
TH2.20: 2,0 Nm
TH2.25: 2,5 Nm
TH2.30: 3,0 Nm
TH2.40: 3,0 Nm



Legende Legend 250

Scan QR-Code Oder besuchen Sie // Or Visit www.simtek.info/cp/1233

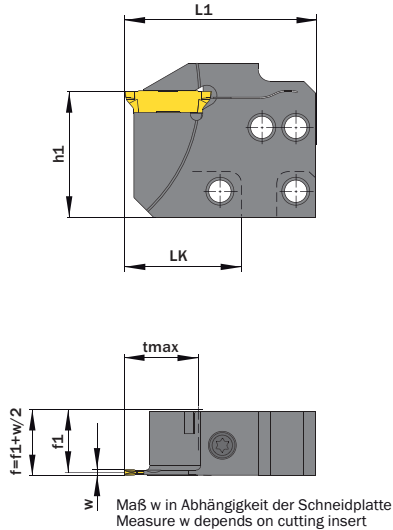
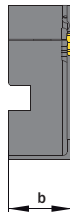
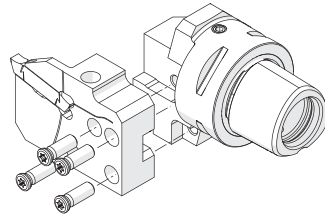


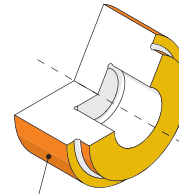
Abbildung zeigt / Drawing shows: TOA.TH2.29.15 R



Grundhalter finden Sie ab Seite 425
Base toolholder can be found on page 425



Schrauben für Kassettenbefestigung
Screw for cassette mounting
T M5x15 T20R



- Hauptsächlich geeignet für diese Flächen
Mainly designed for these surfaces
- Je nach Schneidplatte/Aufnahme ebenfalls möglich
Also possible depending on insert/fixation type

Artikelnummer Part number	Webcode www.simtek.com/webcode	b	f1	h1	L1	tmax	LK	w ≥	w ≤	Schraube Screw	Schraubenschlüssel Screw driver	Connectcode www.simtek.com/cbcode	Adaptcode Adaptcode
TOA.TH2.29.15 R/L	R AZBV L AZBU	16,0	15,3	31,6	47,9	18,0	29,0	-	1,9	TH2 M5x16 T20T	T20T	TH2.15	TOA
TOA.TH2.29.20 R/L	R AZBX L AZBW	16,0	15,0	31,6	47,9	18,0	29,0	1,91	2,4	TH2 M5x16 T20T	T20T	TH2.20	TOA
TOA.TH2.29.25 R/L	R AZBZ L AZBY	16,0	14,8	31,6	47,9	18,0	29,0	2,41	2,9	TH2 M5x16 T20T	T20T	TH2.25	TOA
TOA.TH2.29.30 R/L	R AZB1 L AZB0	16,0	14,6	31,6	47,9	18,0	29,0	2,91	3,8	TH2 M5x16 T20T	T20T	TH2.30	TOA
TOA.TH2.29.40 R/L	R AZB3 L AZB2	16,0	14,5	31,6	47,9	18,0	29,0	3,81	5,0	TH2 M5x16 T20T	T20T	TH2.40	TOA

Bestellbeispiel // Order example: **TOA.TH2.29.20 R** (R = Rechte Ausführung // Right hand version)

Stechdrehen, Sicherungsringnuten

Sicherungsringnuten vgl. DIN 471/472, sowie DIN 983/984.

Grooving, Circlip Ring Grooves

Circlip ring grooves compare DIN 471/472, and DIN 983/984.

Schnittwerte (Start) // Cutting parameters (start)

f (außen//ext.) 0,1 mm/U	f (innen//int.) 0,08 mm/U	Vc Seite/Page 429
------------------------------------	-------------------------------------	-----------------------------

Passende Klemmhalter auf Seite // Suitable toolholders on page

230, 231, 232, 233, 234, 235, 236, 237, 238, 239, 240, 241, 242, 243



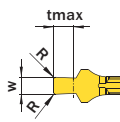
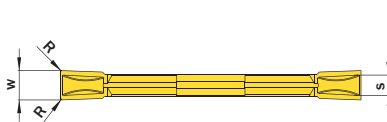
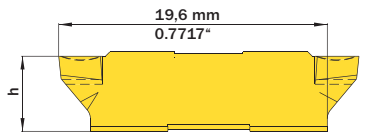
SP Legende
HM Legend

250



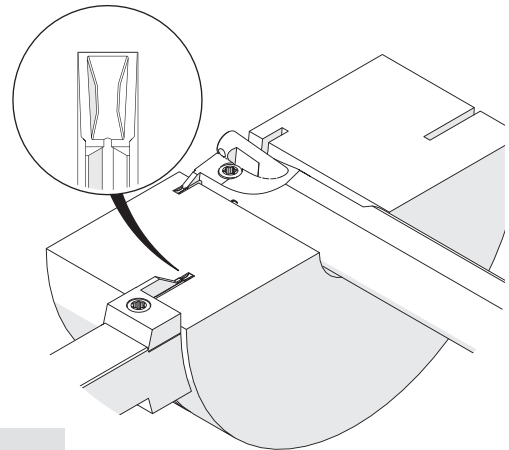
Scan
QR-Code

Oder besuchen Sie // Or Visit
www.simtek.info/cp/486



w > 1,24 mm / 0,0488" tmax in Abhängigkeit des Klemmhalters depends on toolholder

w ≤ 1,24 mm / 0,0488" tmax 1,3 mm / 0,0512"



Nennbreite Nominal width of groove	w ^{+0,03} mm	Artikelnummer Part number	Webcode www.simtek.com/webcode	Unsere erste Wahl Our first choice	h	R	S	Connectcode www.simtek.com/code
1,1	1,2	TH2.110.000 GG	ASF6	X800 X600	5,5	-	1,15	TH2.15
1,3	1,4	TH2.130.000 GG	AHV2	X800 X600	5,5	-	1,15	TH2.15
1,6	1,7	TH2.160.010 GG	AWMF	X800 X600	5,5	0,1	1,15	TH2.15
1,85	1,95	TH2.185.010 GG	AWMG	X800 X600	5,5	0,1	1,6	TH2.20
2,15	2,25	TH2.215.015 GG	AWMH	X800 X600	5,5	0,15	1,6	TH2.20
2,65	2,75	TH2.265.015 GG	AWMJ	X800 X600	5,5	0,15	2,1	TH2.25
3,15	3,25	TH2.315.015 GG	AWMK	X800 X600	5,5	0,15	2,6	TH2.30
4,15	4,25	TH2.415.015 GG	AWMM	X800 X600	5,5	0,15	3,5	TH2.40

Bestellbeispiel // Order example: **TH2.215.015 GG X800** (X800 = Schneidstoff // Grade)



TH2. **w, 1/100 mm, 3 Stellen/Digits** . **R, 1/100 mm, 3 Stellen/Digits** **Toleranz // Tolerance** G
Beispielartikelnummer // Example Part number: **TH2.156.015 XNG**

Einstecken und Profildrehen in Leichtmetallen

CNC-Konturdrehen mit spezieller Geometrie für die Bearbeitung von Leichtmetallen.

Grooving and Profiling in light alloys

CNC profiling with special geometry for applications in light alloys.

Schnittwerte (Start) // Cutting parameters (start)		
f (außen//ext.) 0,1 mm/U	f (innen//int.) 0,08 mm/U	Vc Seite/Page 429

Passende Klemmhalter auf Seite // Suitable toolholders on page	
230, 231, 232, 233, 234, 235, 236, 237, 238, 239, 240, 241, 242, 243	

SP
Legende

HM
Legende

Scan QR-Code

250

Oder besuchen Sie // Or Visit
www.simtek.info/cp/1179

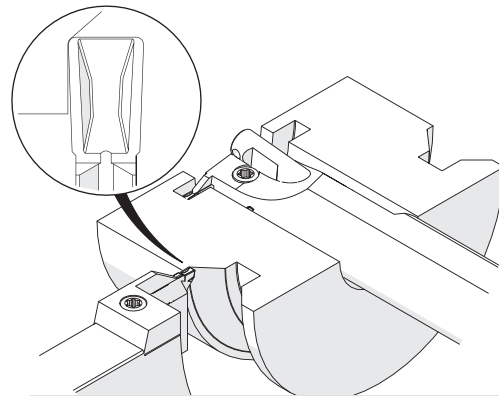
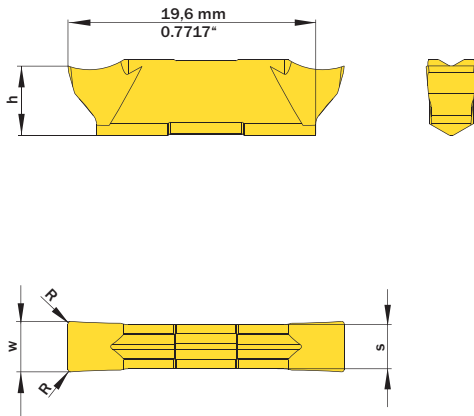


Illustration zeigt beispielhafte Anwendungsmöglichkeit mit ähnlichem Werkzeug.
Image shows exemplary application possibility with similar tool.

Abbildung zeigt / Drawing shows: TH2.400.020 NC

$w^{+0,03}$ mm	R mm	Artikelnummer Part number	Webcode www.simtek.com/webcode	Unsere erste Wahl Our first choice P K M N S	h mm	s mm	Connectcode www.simtek.com/code
▼ R = 0,05 mm							
1,5	0,05	TH2.150.005 NC	AWMC	X808 X408	5,5	1,15	TH2.15
2,0	0,05	TH2.200.005 NC	AZDH	X808 X408	5,5	1,6	TH2.20
2,5	0,05	TH2.250.005 NC	AZDJ	X808 X408	5,5	2,1	TH2.25
3,0	0,05	TH2.300.005 NC	AZDK	X808 X408	5,5	2,65	TH2.30
▼ R = 0,2 mm							
1,5	0,2	TH2.150.020 NC	AZDM	X808 X408	5,5	1,15	TH2.15
2,0	0,2	TH2.200.020 NC	A2HW	X808 X408	5,5	1,6	TH2.20
2,5	0,2	TH2.250.020 NC	AZDP	X808 X408	5,5	2,1	TH2.25
3,0	0,2	TH2.300.020 NC	AZDQ	X808 X408	5,5	2,65	TH2.30
3,5	0,2	TH2.350.020 NC	AZDS	X808 X408	5,5	2,65	TH2.30
4,0	0,2	TH2.400.020 NC	AZDT	X808 X408	5,5	3,5	TH2.40
▼ R = 0,4 mm							
3,0	0,4	TH2.300.040 NC	AZDU	X808 X408	5,5	2,65	TH2.30
3,5	0,4	TH2.350.040 NC	A1QU	X808 X408	5,5	2,65	TH2.30
4,0	0,4	TH2.400.040 NC	AZDW	X808 X408	5,5	3,5	TH2.40

Bestellbeispiel // Order example: **TH2.150.005 NC HF25** (HF25 = Schneidstoff // Grade)

Einstecken und Profildrehen

CNC-Konturdrehen.

Grooving and Profiling

CNC profiling.

Schnittwerte (Start) // Cutting parameters (start)

f (außen//ext.) 0,1 mm/U	f (innen//int.) 0,08 mm/U	Vc Seite/Page 429
------------------------------------	-------------------------------------	-----------------------------

Passende Klemmhalter auf Seite // Suitable toolholders on page

230, 231, 232, 233, 234, 235, 236, 237, 238, 239, 240, 241, 242, 243



SP Legende
HM Legend

250



Scan
QR-Code

Oder besuchen Sie // Or Visit
www.simtek.info/cp/483

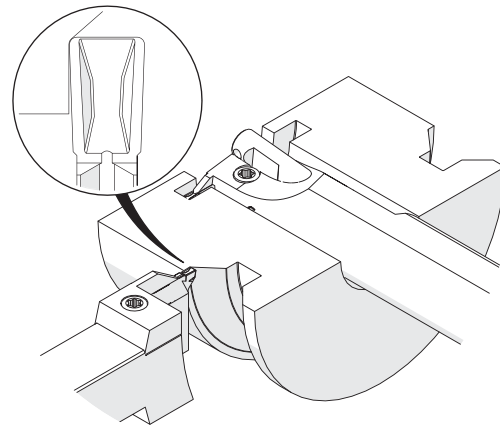
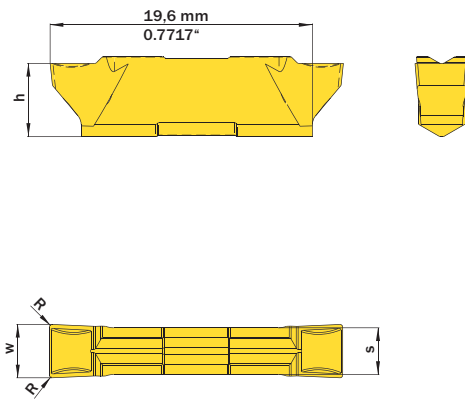


Abbildung zeigt / Drawing shows: TH2.400.020 NG

$w^{+0,03}$ mm	R mm	Artikelnummer Part number	Webcode www.simtek.com/webcode	Unsere erste Wahl Our first choice P K M N S	h mm	s mm	Connectcode www.simtek.com/code
▼ R = 0,05 mm							
1,5	0,05	TH2.150.005 NG	AF26	X800 X600	5,5	1,15	TH2.15
2,0	0,05	TH2.200.005 NG	AHEM	X800 X600	5,5	1,6	TH2.20
2,5	0,05	TH2.250.005 NG	AKG3	X800 X600	5,5	2,1	TH2.25
3,0	0,05	TH2.300.005 NG	ACFA	X800 X600	5,5	2,65	TH2.30
▼ R = 0,2 mm							
1,5	0,2	TH2.150.020 NG	ADSK	X800 X600	5,5	1,15	TH2.15
2,0	0,2	TH2.200.020 NG	AEHZ	X800 X600	5,5	1,6	TH2.20
2,5	0,2	TH2.250.020 NG	APQW	X800 X600	5,5	2,1	TH2.25
3,0	0,2	TH2.300.020 NG	AFZM	X800 X600	5,5	2,65	TH2.30
3,2	0,2	TH2.318.020 NG	A5WQ	X800 X600	5,5	2,65	TH2.30 <small>new inch</small>
3,5	0,2	TH2.350.020 NG	ASY7	X800 X600	5,5	2,65	TH2.30
4,0	0,2	TH2.400.020 NG	AKDM	X800 X600	5,5	3,5	TH2.40
▼ R = 0,4 mm							
3,0	0,4	TH2.300.040 NG	AGVW	X800 X600	5,5	2,65	TH2.30
3,2	0,4	TH2.318.040 NG	A6H1	X800 X600	5,5	2,6	TH2.30 <small>new inch</small>
3,5	0,4	TH2.350.040 NG	ASY8	X800 X600	5,5	2,65	TH2.30
4,0	0,4	TH2.400.040 NG	ABAZ	X800 X600	5,5	3,5	TH2.40

Bestellbeispiel // Order example: **TH2.150.020 NG X800** (X800 = Schneidstoff // Grade)



TH2. $w, 1/100$ mm, 3 Stellen/Digits . $R, 1/100$ mm, 3 Stellen/Digits Toleranz // Tolerance G

Beispielartikelnummer // Example Part number: **TH2.156.015 XNG**

Einstecken und Profildrehen, Vollradius

Vollradiusnuten, CNC-Konturdrehen.

Grooving and Profiling, Full Radius

Full radius, CNC profiling.

Schnittwerte (Start) // Cutting parameters (start)		
f (außen//ext.) 0,05 mm/U	f (innen//int.) 0,04 mm/U	Vc Seite/Page 429

Passende Klemmhalter auf Seite // Suitable toolholders on page
230, 231, 232, 233, 234, 235, 236, 237, 238, 239, 240, 241, 242, 243

SP

Legende

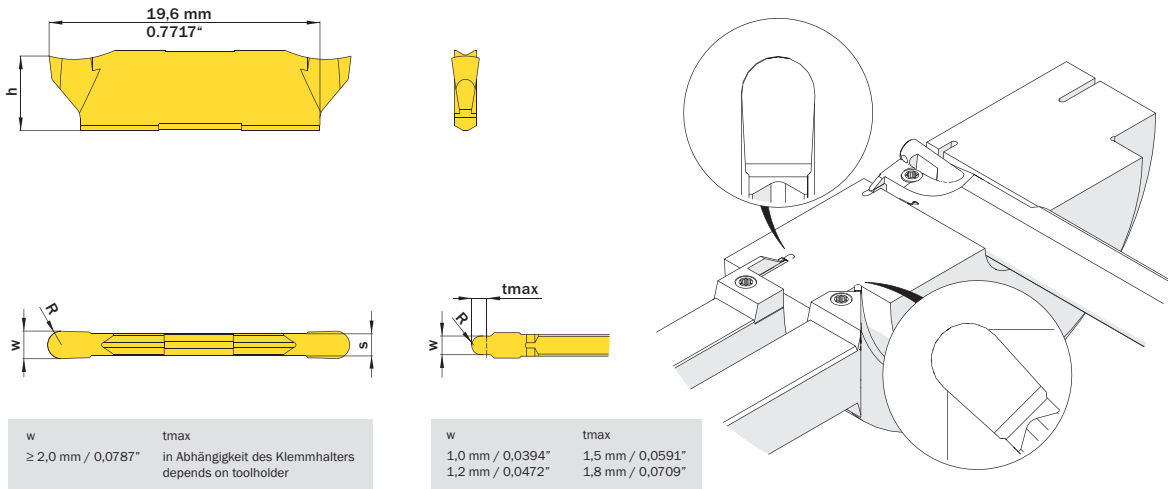
HM

Legende

Scan

QR-Code

Oder besuchen Sie // Or Visit
www.simtek.info/cp/485



$w^{+0,05}$	R	Artikelnummer Part number	Webcode www.simtek.com/webcode	Unsere erste Wahl Our first choice	h	s	Connectcode www.simtek.com/ccode
mm	mm			P K M N S	mm	mm	
1,0	0,5	TH2.100.050 VS	ASZF	X800 X600	5,4	1,15	TH2.15
1,2	0,6	TH2.120.060 VS	ASZE	X800 X600	5,4	1,15	TH2.15
2,0	1,0	TH2.200.100 VS	ASZD	X800 X600	5,4	1,6	TH2.20
2,5	1,25	TH2.250.125 VS	ASZC	X800 X600	5,4	2,1	TH2.25
3,0	1,5	TH2.300.150 VS	ASZB	X800 X600	5,4	2,65	TH2.30
4,0	2,0	TH2.400.200 VS	ASZA	X800 X600	5,4	3,5	TH2.40
5,0	2,5	TH2.500.250 VS	ASY9	X800 X600	5,4	3,5	TH2.40

Bestellbeispiel // Order example: **TH2.200.100 VS X800** (X800 = Schneidstoff // Grade)

Abstechen

Verfügbar in verschiedenen Winkeln und Breiten.

Parting Off

Available in different angles and widths.

Schnittwerte (Start) // Cutting parameters (start)		
f (außen//ext.) 0,1 mm/U	f (innen//int.) 0,08 mm/U	Vc Seite/Page 429

Passende Klemmhalter auf Seite // Suitable toolholders on page
230, 231, 232, 233, 234, 235, 236, 237, 238, 239, 240, 241, 242, 243

SP

Legende

HM

Legende

250

Scan
QR-Code

Oder besuchen Sie // Or Visit
www.simtek.info/cp/735

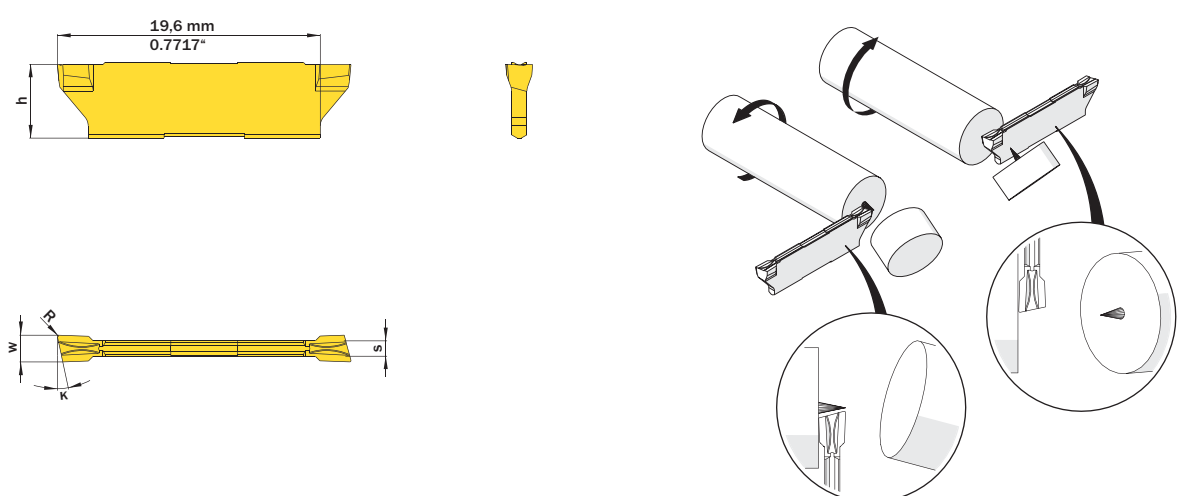


Abbildung zeigt / Drawing shows: TH2.R200.12 PG

$w^{-0,05}$ mm	R mm	K	Artikelnummer Part number	Webcode www.simtek.com/webcode	Unsere erste Wahl Our first choice	h mm	S mm	Connectcode www.simtek.com/code
▼ w = 1,5 mm								
1,5	0,1	6°	TH2.R150.06 PG	A2T4	X800 X600	5,5	1,15	TH2.15
▼ w = 2,0 mm								
2,0	0,1	6°	TH2.R200.06 PG	ATPG	X800 X600	5,5	1,6	TH2.20
2,0	0,1	12°	TH2.R200.12 PG	ATPJ	X800 X600	5,5	1,6	TH2.20
▼ w = 2,5 mm								
2,5	0,1	6°	TH2.R250.06 PG	ATPM	X800 X600	5,5	2,1	TH2.25
2,5	0,1	12°	TH2.R250.12 PG	ATPP	X800 X600	5,5	2,1	TH2.25
▼ w = 3,0 mm								
3,0	0,1	6°	TH2.R300.06 PG	ATPS	X800 X600	5,5	2,64	TH2.30
3,0	0,1	12°	TH2.R300.12 PG	ATPU	X800 X600	5,5	2,64	TH2.30

Bestellbeispiel // Order example: **TH2.R200.12 PG X800** (X800 = Schneidstoff // Grade)

Abstechen

Verfügbar in verschiedenen Winkeln und Breiten.

Parting Off

Available in different angles and widths.

Schnittwerte (Start) // Cutting parameters (start)		
f (außen//ext.) 0,1 mm/U	f (innen//int.) 0,08 mm/U	Vc Seite/Page 429

Passende Klemmhalter auf Seite // Suitable toolholders on page
230, 231, 232, 233, 234, 235, 236, 237, 238, 239, 240, 241, 242, 243

SP

Legende

HM

Legend

250

Scan QR-Code

Oder besuchen Sie // Or Visit www.simtek.info/cp/725

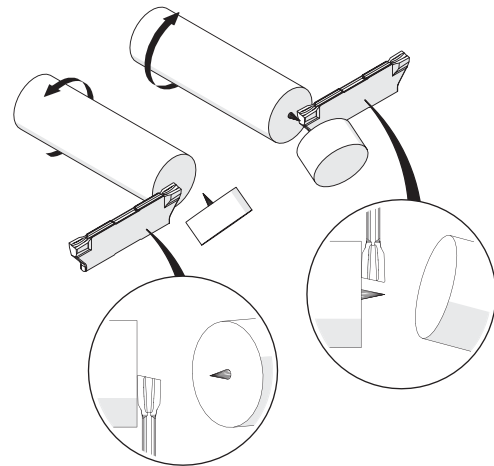
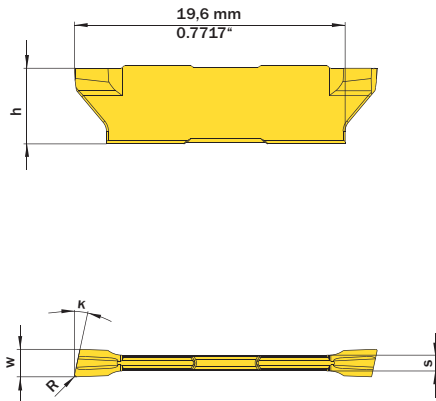



Abbildung zeigt / Drawing shows: TH2.L200.12 PG

$w^{-0,05}$ mm	R mm	K	Artikelnummer Part number	Webcode www.simtek.com/webcode	Unsere erste Wahl Our first choice	h mm	s mm	Connectcode www.simtek.com/code
▼ w = 1,5 mm								
1,5	0,1	6°	TH2.L150.06 PG	A2V0	X800 X600	5,5	1,15	TH2.15
▼ w = 2,0 mm								
2,0	0,1	6°	TH2.L200.06 PG	ATPH	X800 X600	5,5	1,6	TH2.20
2,0	0,1	12°	TH2.L200.12 PG	ATPK	X800 X600	5,5	1,6	TH2.20
▼ w = 2,5 mm								
2,5	0,1	6°	TH2.L250.06 PG	ATPN	X800 X600	5,5	2,1	TH2.25
2,5	0,1	12°	TH2.L250.12 PG	ATPQ	X800 X600	5,5	2,1	TH2.25
▼ w = 3,0 mm								
3,0	0,1	6°	TH2.L300.06 PG	ATPT	X800 X600	5,5	2,64	TH2.30
3,0	0,1	12°	TH2.L300.12 PG	ATPV	X800 X600	5,5	2,64	TH2.30

Bestellbeispiel // Order example: **TH2.L200.12 PG X800** (X800 = Schneidstoff // Grade)

Info

Legende
Legend

- SP** Schneidwerkzeug aus Hartmetall // Carbide insert // Outils coupants en carbure de tungstène // Inserto in metallo duro
HM Inserto de carburo // Karbür kesici uç
- TW** Trägerwerkzeug aus Stahl // Steel toolholder // Porte-outils en acier // Porta inserto in acciaio
ST Porta-herramientas de acero // Çelik tutucu
- R** Rechts wie gezeichnet // Right hand version shown, left hand version inversely // A droite comme présenté // In figura utensile destro
 Modelo derecho // Sağ model
-  Innere Kühlmittelzufuhr // Through coolant // Refroidissement interne // Lubrificazione interna
 Con refrigeración interna // İçten soğutma

Index

simturn H2 Produktverzeichnis
simturn H2 Product List

Artikelnr. // Part Nr.	S/P	Artikelnr. // Part Nr.	S/P	Artikelnr. // Part Nr.	S/P	Artikelnr. // Part Nr.	S/P	Artikelnr. // Part Nr.	S/P
TH2.0.500.S.A13.12.15 L	235	TH2.0020.A25.48.11.30 L	230	TH2.0032.A31.61.12.20 L	231	TH2.1.000.B31.61.12.40 L	233	TH2.1212.A13.12.15 L	235
TH2.0.500.S.A13.12.15 R	235	TH2.0020.A25.48.11.30 R	230	TH2.0032.A31.61.12.20 R	231	TH2.1.000.B31.61.12.40 R	233	TH2.1212.A13.12.15 R	235
TH2.0.500.S.A13.12.20 L	235	TH2.0020.A25.48.11.40 L	230	TH2.0032.A31.61.12.25 L	231	TH2.1.000.S.B18.15.15 L	237	TH2.1212.A13.12.20 L	235
TH2.0.500.S.A13.12.20 R	235	TH2.0020.A25.48.11.40 R	230	TH2.0032.A31.61.12.25 R	231	TH2.1.000.S.B18.15.15 R	237	TH2.1212.A13.12.20 R	235
TH2.0.500.S.A13.12.25 L	235	TH2.0020.B25.48.11.15 L	232	TH2.0032.A31.61.12.30 L	231	TH2.1.000.S.B18.15.20 L	237	TH2.1212.A13.12.25 L	235
TH2.0.500.S.A13.12.25 R	235	TH2.0020.B25.48.11.15 R	232	TH2.0032.A31.61.12.30 R	231	TH2.1.000.S.B18.15.20 R	237	TH2.1212.A13.12.25 R	235
TH2.0.500.S.A13.12.30 L	235	TH2.0020.B25.48.11.20 L	232	TH2.0032.A31.61.12.40 L	231	TH2.1.000.S.B18.15.25 L	237	TH2.1212.A13.12.30 L	235
TH2.0.500.S.A13.12.30 R	235	TH2.0020.B25.48.11.20 R	232	TH2.0032.A31.61.12.40 R	231	TH2.1.000.S.B18.15.25 R	237	TH2.1212.A13.12.30 R	235
TH2.0.500.S.A13.12.40 L	235	TH2.0020.B25.48.11.25 L	232	TH2.0032.B31.61.12.15 L	233	TH2.1.000.S.B18.15.30 L	237	TH2.1212.A13.12.40 L	235
TH2.0.500.S.A13.12.40 R	235	TH2.0020.B25.48.11.25 R	232	TH2.0032.B31.61.12.15 R	233	TH2.1.000.S.B18.15.30 R	237	TH2.1212.A13.12.40 R	235
TH2.0.625.S.B18.12.15 L	236	TH2.0020.B25.48.11.30 L	232	TH2.0032.B31.61.12.15 R	233	TH2.1.000.S.B18.15.40 L	237	TH2.1212.A13.12.40 R	235
TH2.0.625.S.B18.12.15 R	236	TH2.0020.B25.48.11.30 R	232	TH2.0032.B31.61.12.20 R	233	TH2.1.000.S.B18.15.40 R	237	TH2.150.000 GG	244
TH2.0.625.S.B18.12.20 L	236	TH2.0020.B25.48.11.40 L	232	TH2.0032.B31.61.12.20 R	233	TH2.1.000.S.C10.15.15 L	239	TH2.150.005 NC	245
TH2.0.625.S.B18.12.20 R	236	TH2.0020.B25.48.11.40 R	232	TH2.0032.B31.61.12.25 L	233	TH2.1.000.S.C10.15.15 R	239	TH2.150.020 NC	245
TH2.0.625.S.B18.12.25 L	236	TH2.0020.D45.60.18.15 L	242	TH2.0032.B31.61.12.30 L	233	TH2.1.000.S.C10.15.20 L	239	TH2.150.020 NG	246
TH2.0.625.S.B18.12.25 R	236	TH2.0020.D45.60.18.15 R	242	TH2.0032.B31.61.12.30 R	233	TH2.1.000.S.C10.15.20 R	239	TH2.160.010 GG	244
TH2.0.625.S.B18.12.30 L	236	TH2.0020.D45.60.18.20 L	242	TH2.0032.B31.61.12.40 L	233	TH2.1.000.S.C10.15.25 L	239	TH2.1616.B18.12.15 L	236
TH2.0.625.S.B18.12.30 R	236	TH2.0020.D45.60.18.20 R	242	TH2.0032.B31.61.12.40 R	233	TH2.1.000.S.C10.15.25 R	239	TH2.1616.B18.12.15 R	236
TH2.0.625.S.B18.12.40 L	236	TH2.0020.D45.60.18.25 L	242	TH2.0032.D45.80.25.15 L	242	TH2.1.000.S.C10.15.30 L	239	TH2.1616.B18.12.20 L	236
TH2.0.625.S.B18.12.40 R	236	TH2.0020.D45.60.18.25 R	242	TH2.0032.D45.80.25.15 R	242	TH2.1.000.S.C10.15.30 R	239	TH2.1616.B18.12.20 R	236
TH2.0.750.A25.48.12.15 L	230	TH2.0020.D45.60.18.30 L	242	TH2.0032.D45.80.25.20 L	242	TH2.1.000.S.C10.15.40 L	239	TH2.1616.B18.12.25 L	236
TH2.0.750.A25.48.12.15 R	230	TH2.0020.D45.60.18.30 R	242	TH2.0032.D45.80.25.20 R	242	TH2.1.000.S.C10.15.40 R	239	TH2.1616.B18.12.25 R	236
TH2.0.750.A25.48.12.20 L	230	TH2.0020.D45.60.18.40 L	242	TH2.0032.D45.80.25.25 L	242	TH2.1.000.S.D45.15.15 L	241	TH2.1616.B18.12.30 L	236
TH2.0.750.A25.48.12.20 R	230	TH2.0020.D45.60.18.40 R	242	TH2.0032.D45.80.25.25 R	242	TH2.1.000.S.D45.15.15 R	241	TH2.1616.B18.12.30 R	236
TH2.0.750.A25.48.12.25 L	230	TH2.0025.A25.48.12.15 L	230	TH2.0032.D45.80.25.30 L	242	TH2.1.000.S.D45.15.20 L	241	TH2.1616.B18.12.40 L	236
TH2.0.750.A25.48.12.25 R	230	TH2.0025.A25.48.12.15 R	230	TH2.0032.D45.80.25.30 R	242	TH2.1.000.S.D45.15.20 R	241	TH2.1616.B18.12.40 R	236
TH2.0.750.A25.48.12.30 L	230	TH2.0025.A25.48.12.20 L	230	TH2.0032.D45.80.25.40 L	242	TH2.1.000.S.D45.15.25 L	241	TH2.1616.C10.12.15 L	238
TH2.0.750.A25.48.12.30 R	230	TH2.0025.A25.48.12.20 R	230	TH2.0032.D45.80.25.40 R	242	TH2.1.000.S.D45.15.25 R	241	TH2.1616.C10.12.15 R	238
TH2.0.750.A25.48.12.40 L	230	TH2.0025.A25.48.12.25 L	230	TH2.1.000.A25.48.12.15 L	230	TH2.1.000.S.D45.15.30 L	241	TH2.1616.C10.12.20 L	238
TH2.0.750.A25.48.12.40 R	230	TH2.0025.A25.48.12.25 R	230	TH2.1.000.A25.48.12.15 R	230	TH2.1.000.S.D45.15.30 R	241	TH2.1616.C10.12.20 R	238
TH2.0.750.S.B18.12.15 L	236	TH2.0025.A25.48.12.30 L	230	TH2.1.000.A25.48.12.20 L	230	TH2.1.000.S.D45.15.40 L	241	TH2.1616.C10.12.25 L	238
TH2.0.750.S.B18.12.15 R	236	TH2.0025.A25.48.12.30 R	230	TH2.1.000.A25.48.12.20 R	230	TH2.1.000.S.D45.15.40 R	241	TH2.1616.C10.12.25 R	238
TH2.0.750.S.B18.12.20 L	236	TH2.0025.A25.48.12.40 L	230	TH2.1.000.A25.48.12.25 L	230	TH2.1.250.D45.80.25.15 R	242	TH2.1616.C10.12.30 L	238
TH2.0.750.S.B18.12.20 R	236	TH2.0025.A25.48.12.40 R	230	TH2.1.000.A25.48.12.25 R	230	TH2.1.250.D45.80.25.20 R	242	TH2.1616.C10.12.30 R	238
TH2.0.750.S.B18.12.25 L	236	TH2.0025.A31.61.12.15 L	231	TH2.1.000.A25.48.12.30 L	230	TH2.1.250.D45.80.25.25 R	242	TH2.1616.C10.12.40 L	238
TH2.0.750.S.B18.12.25 R	236	TH2.0025.A31.61.12.15 R	231	TH2.1.000.A25.48.12.30 R	230	TH2.1.250.D45.80.25.30 R	242	TH2.1616.C10.12.40 R	238
TH2.0.750.S.B18.12.30 L	236	TH2.0025.A31.61.12.20 L	231	TH2.1.000.A25.48.12.40 L	230	TH2.1.250.D45.80.25.40 R	242	TH2.185.010 GG	244
TH2.0.750.S.B18.12.30 R	236	TH2.0025.A31.61.12.20 R	231	TH2.1.000.A25.48.12.40 R	230	TH2.100.050 VS	247	TH2.200.005 NC	245
TH2.0.750.S.B18.12.40 L	236	TH2.0025.A31.61.12.25 L	231	TH2.1.000.A31.61.12.15 L	231	TH2.1010.A11.08.15 L	234	TH2.200.005 NC	246
TH2.0.750.S.B18.12.40 R	236	TH2.0025.A31.61.12.25 R	231	TH2.1.000.A31.61.12.15 R	231	TH2.1010.A11.08.15 R	234	TH2.200.020 NG	245
TH2.0.750.S.C10.12.15 L	238	TH2.0025.A31.61.12.30 L	231	TH2.1.000.A31.61.12.20 L	231	TH2.1010.A11.08.20 L	234	TH2.200.020 NG	246
TH2.0.750.S.C10.12.15 R	238	TH2.0025.A31.61.12.30 R	231	TH2.1.000.A31.61.12.20 R	231	TH2.1010.A11.08.20 R	234	TH2.200.100 VS	247
TH2.0.750.S.C10.12.20 L	238	TH2.0025.A31.61.12.40 L	231	TH2.1.000.A31.61.12.25 L	231	TH2.1010.A11.08.25 L	234	TH2.2020.B18.12.15 L	236
TH2.0.750.S.C10.12.20 R	238	TH2.0025.A31.61.12.40 R	231	TH2.1.000.A31.61.12.25 R	231	TH2.1010.A11.08.25 R	234	TH2.2020.B18.12.15 R	236
TH2.0.750.S.C10.12.25 L	238	TH2.0025.B25.48.12.15 L	232	TH2.1.000.A31.61.12.30 L	231	TH2.1010.A11.08.30 L	234	TH2.2020.B18.12.20 L	236
TH2.0.750.S.C10.12.25 R	238	TH2.0025.B25.48.12.15 R	232	TH2.1.000.A31.61.12.30 R	231	TH2.1010.A11.08.30 R	234	TH2.2020.B18.12.20 R	236
TH2.0.750.S.C10.12.30 L	238	TH2.0025.B25.48.12.20 L	232	TH2.1.000.A31.61.12.40 L	231	TH2.1010.A11.12.15 L	234	TH2.2020.B18.12.25 L	236
TH2.0.750.S.C10.12.30 R	238	TH2.0025.B25.48.12.20 R	232	TH2.1.000.A31.61.12.40 R	231	TH2.1010.A11.12.15 R	234	TH2.2020.B18.12.25 R	236
TH2.0.750.S.C10.12.40 L	238	TH2.0025.B25.48.12.25 L	232	TH2.1.000.B25.48.12.15 L	232	TH2.1010.A11.12.20 L	234	TH2.2020.B18.12.30 L	236
TH2.0.750.S.C10.12.40 R	238	TH2.0025.B25.48.12.25 R	232	TH2.1.000.B25.48.12.15 R	232	TH2.1010.A11.12.20 R	234	TH2.2020.B18.12.30 R	236
TH2.0.750.S.D45.12.15 L	240	TH2.0025.B25.48.12.30 L	232	TH2.1.000.B25.48.12.20 L	232	TH2.1010.A11.12.25 L	234	TH2.2020.B18.12.40 L	236
TH2.0.750.S.D45.12.15 R	240	TH2.0025.B25.48.12.30 R	232	TH2.1.000.B25.48.12.20 R	232	TH2.1010.A11.12.25 R	234	TH2.2020.B18.12.40 R	236
TH2.0.750.S.D45.12.20 L	240	TH2.0025.B25.48.12.40 L	232	TH2.1.000.B25.48.12.25 L	232	TH2.1010.A11.12.30 L	234	TH2.2020.C10.12.15 L	238
TH2.0.750.S.D45.12.20 R	240	TH2.0025.B25.48.12.40 R	232	TH2.1.000.B25.48.12.25 R	232	TH2.1010.A11.12.30 R	234	TH2.2020.C10.12.15 R	238
TH2.0.750.S.D45.12.25 L	240	TH2.0025.B31.61.12.15 L	233	TH2.1.000.B25.48.12.30 L	232	TH2.110.000 GG	244	TH2.2020.C10.12.20 L	238
TH2.0.750.S.D45.12.25 R	240	TH2.0025.B31.61.12.15 R	233	TH2.1.000.B25.48.12.30 R	232	TH2.120.060 VS	247	TH2.2020.C10.12.20 R	238
TH2.0.750.S.D45.12.30 L	240	TH2.0025.B31.61.12.20 L	233	TH2.1.000.B25.48.12.40 L	232	TH2.1212.A13.08.15 L	235	TH2.2020.C10.12.25 L	238
TH2.0.750.S.D45.12.30 R	240	TH2.0025.B31.61.12.20 R	233	TH2.1.000.B25.48.12.40 R	232	TH2.1212.A13.08.15 R	235	TH2.2020.C10.12.25 R	238
TH2.0.750.S.D45.12.40 L	240	TH2.0025.B31.61.12.25 L	233	TH2.1.000.B31.61.12.15 L	233	TH2.1212.A13.08.20 L	235	TH2.2020.C10.12.30 L	238
TH2.0.750.S.D45.12.40 R	240	TH2.0025.B31.61.12.25 R	233	TH2.1.000.B31.61.12.15 R	233	TH2.1212.A13.08.20 R	235	TH2.2020.C10.12.30 R	238
TH2.0020.A25.48.11.15 L	230	TH2.0025.B31.61.12.30 L	233	TH2.1.000.B31.61.12.20 L	233	TH2.1212.A13.08.25 L	235	TH2.2020.C10.12.40 L	238
TH2.0020.A25.48.11.15 R	230	TH2.0025.B31.61.12.30 R	233	TH2.1.000.B31.61.12.20 R	233	TH2.1212.A13.08.25 R	235	TH2.2020.C10.12.40 R	238
TH2.0020.A25.48.11.20 L	230	TH2.0025.B31.61.12.40 L	233	TH2.1.000.B31.61.12.25 L	233	TH2.1212.A13.08.30 L	235	TH2.2020.D45.12.15 L	240
TH2.0020.A25.48.11.20 R	230	TH2.0025.B31.61.12.40 R	233	TH2.1.000.B31.61.12.25 R	233	TH2.1212.A13.08.30 R	235	TH2.2020.D45.12.15 R	240
TH2.0020.A25.48.11.25 L	230	TH2.0032.A31.61.12.15 L	231	TH2.1.000.B31.61.12.30 L	233	TH2.1212.A13.08.40 L	235	TH2.2020.D45.12.20 L	240
TH2.0020.A25.48.11.25 R	230	TH2.0032.A31.61.12.15 R	231	TH2.1.000.B31.61.12.30 R	233	TH2.1212.A13.08.40 R	235	TH2.2020.D45.12.20 R	240

simturn AX

simturn DX

simturn PX

simturn H2

simturn K2

simturn C4

simturn GX

simturn E3

simturn E12

simturn FX

simturn Decolletage

simturn OA

Index

Index

simturn H2 Produktverzeichnis
simturn H2 Product List

Artikelnr. // Part Nr.	S/P	Artikelnr. // Part Nr.	S/P
TH2.2020.D45.12.25 R	240	TH2.L250.06 PG	249
TH2.2020.D45.12.30 L	240	TH2.L250.12 PG	249
TH2.2020.D45.12.30 R	240	TH2.L300.06 PG	249
TH2.2020.D45.12.40 L	240	TH2.L300.12 PG	249
TH2.2020.D45.12.40 R	240	TH2.R150.06 PG	248
TH2.215.015 GG	244	TH2.R200.06 PG	248
TH2.250.005 NC	245	TH2.R200.12 PG	248
TH2.250.005 NG	246	TH2.R250.06 PG	248
TH2.250.020 NC	245	TH2.R250.12 PG	248
TH2.250.020 NG	246	TH2.R300.06 PG	248
TH2.250.125 VS	247	TH2.R300.12 PG	248
TH2.2525.B18.15.15 L	237	TOA.TH2.29.15 L	243
TH2.2525.B18.15.15 R	237	TOA.TH2.29.15 R	243
TH2.2525.B18.15.20 L	237	TOA.TH2.29.20 L	243
TH2.2525.B18.15.20 R	237	TOA.TH2.29.20 R	243
TH2.2525.B18.15.25 L	237	TOA.TH2.29.25 L	243
TH2.2525.B18.15.25 R	237	TOA.TH2.29.25 R	243
TH2.2525.B18.15.30 L	237	TOA.TH2.29.30 L	243
TH2.2525.B18.15.30 R	237	TOA.TH2.29.30 R	243
TH2.2525.B18.15.40 L	237	TOA.TH2.29.40 L	243
TH2.2525.B18.15.40 R	237	TOA.TH2.29.40 R	243
TH2.2525.C10.15.15 L	239		
TH2.2525.C10.15.15 R	239		
TH2.2525.C10.15.20 L	239		
TH2.2525.C10.15.20 R	239		
TH2.2525.C10.15.25 L	239		
TH2.2525.C10.15.25 R	239		
TH2.2525.C10.15.30 L	239		
TH2.2525.C10.15.30 R	239		
TH2.2525.C10.15.40 L	239		
TH2.2525.C10.15.40 R	239		
TH2.2525.D45.15.15 L	241		
TH2.2525.D45.15.15 R	241		
TH2.2525.D45.15.20 L	241		
TH2.2525.D45.15.20 R	241		
TH2.2525.D45.15.25 L	241		
TH2.2525.D45.15.25 R	241		
TH2.2525.D45.15.30 L	241		
TH2.2525.D45.15.30 R	241		
TH2.2525.D45.15.40 L	241		
TH2.2525.D45.15.40 R	241		
TH2.265.015 GG	244		
TH2.300.005 NC	245		
TH2.300.005 NG	246		
TH2.300.020 NC	245		
TH2.300.020 NG	246		
TH2.300.040 NC	245		
TH2.300.040 NG	246		
TH2.300.150 VS	247		
TH2.315.015 GG	244		
TH2.318.020 NG	246		
TH2.318.040 NG	246		
TH2.350.020 NC	245		
TH2.350.020 NG	246		
TH2.350.040 NC	245		
TH2.350.040 NG	246		
TH2.400.020 NC	245		
TH2.400.020 NG	246		
TH2.400.040 NC	245		
TH2.400.040 NG	246		
TH2.400.200 VS	247		
TH2.415.015 GG	244		
TH2.500.250 VS	247		
TH2.L150.06 PG	249		
TH2.L200.06 PG	249		
TH2.L200.12 PG	249		

Das Werkzeugsystem im Überblick
The Tool System Overview

Kleinteilebearbeitung, außen mit **zwei Schneiden**. Small part machining external, with **two-edged inserts**.

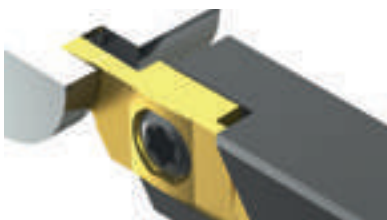
Alle Anwendungen auf einen Blick / All applications at one glance

Einstecken und Profildrehen · Längsdrehen · Gewinden · Abstechen
Grooving and Profiling · Turning · Threading · Parting-Off

Detaillierte Übersicht aller Anwendungen ab Seite 256
Detailed overview of all applications as of page 256

Hauptanwendungen // Main Applications

Einstecken und Profildrehen Grooving and Profiling



Wendeschneidplatten für das Einstecken und Profildrehen außen mit Schneidenbreiten zwischen 0,5 mm und 3,0 mm, verschiedenen Eckenradien und Schneidengeometrien. Auch als Vollradiuswerkzeuge erhältlich.

Indexable inserts for external grooving and profiling applications with cutting edge widths between 0.5 mm and 3.0 mm, different corner radii and cutting edge geometries. Also available as full radius tools.

Längsdrehen Turning



Schneidwerkzeuge mit verschiedenen Eckenradien zum Längsdrehen bzw. Rückwärtsdrehen „hinter Bund“ oder mit zwei auf der Drehmitte liegenden Schneiden für das Längsdrehen und Einstecken mit einem Werkzeug.

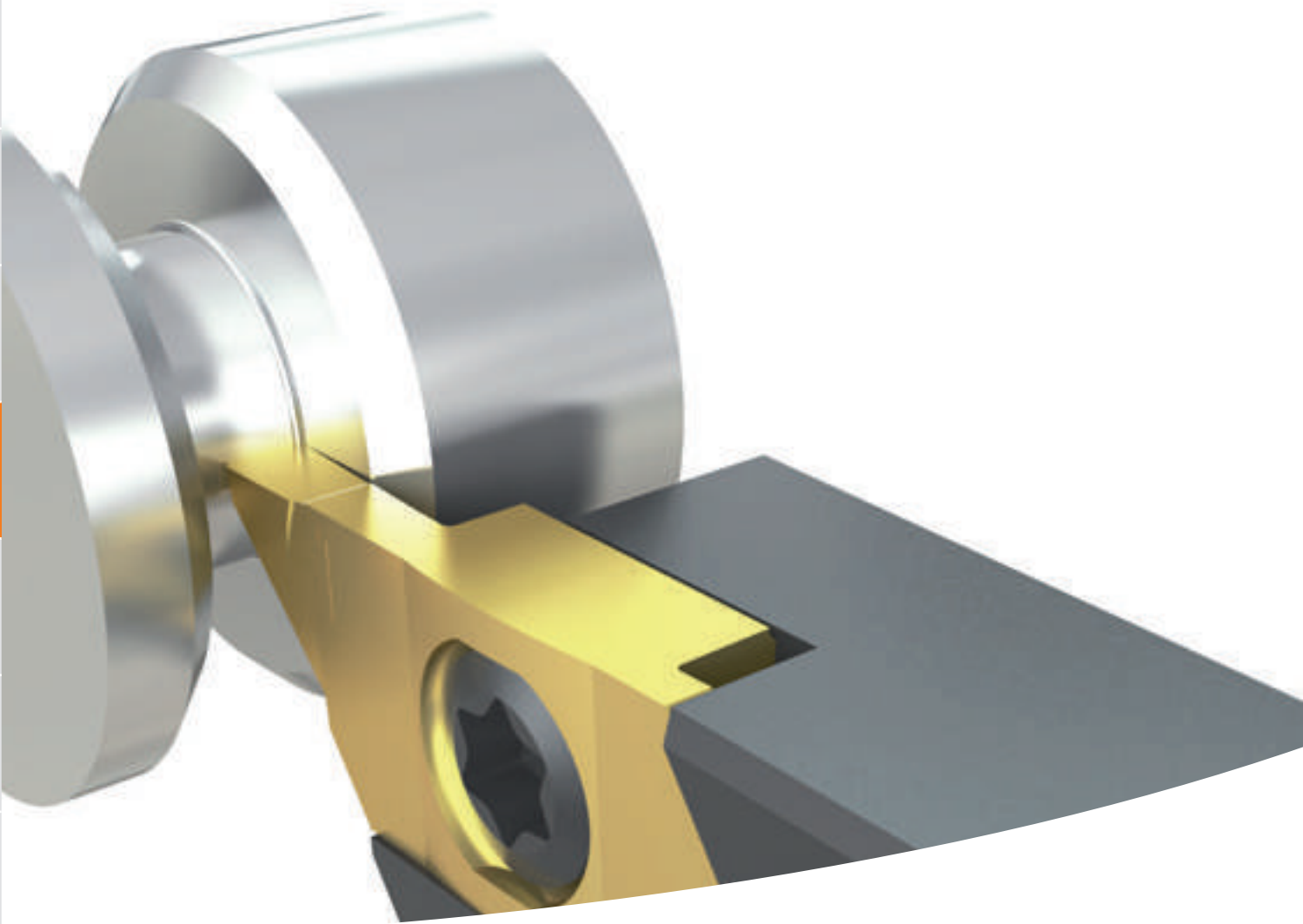
Cutting tools with different corner radii for longitudinal turning or back turning „behind shoulder“ or with two cutting edges located directly on the rotation center for turning and grooving with one tool.

Gewinden Threading

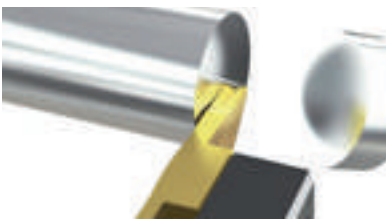


Große Auswahl an Wendeschneidplatten für das Herstellen metrischer ISO-Teil- und Vollprofil Gewinde. Speziell ausgelegt für die Bearbeitung von Messing, Kupferlegierungen und anderen kurzspanenden Werkstoffen.

Wide range of inserts for the machining of metric ISO partial and full profile threads. Specially designed for the machining of brass, copper alloys and other short-chipping workpiece materials.



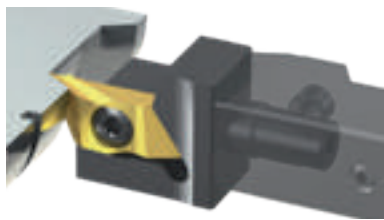
Abstechen Parting-Off



Abstechwerkzeuge mit Schneidenbreiten zwischen 1,0 mm und 2,0 mm, verschiedenen Winkeln sowie mit oder ohne geschliffener Spanformrille.

Tools for parting-off with cutting edge widths between 1.0 mm and 2.0 mm, different front-angles and with or without ground chip form channel.

Schnellwechselsysteme Quick change systems



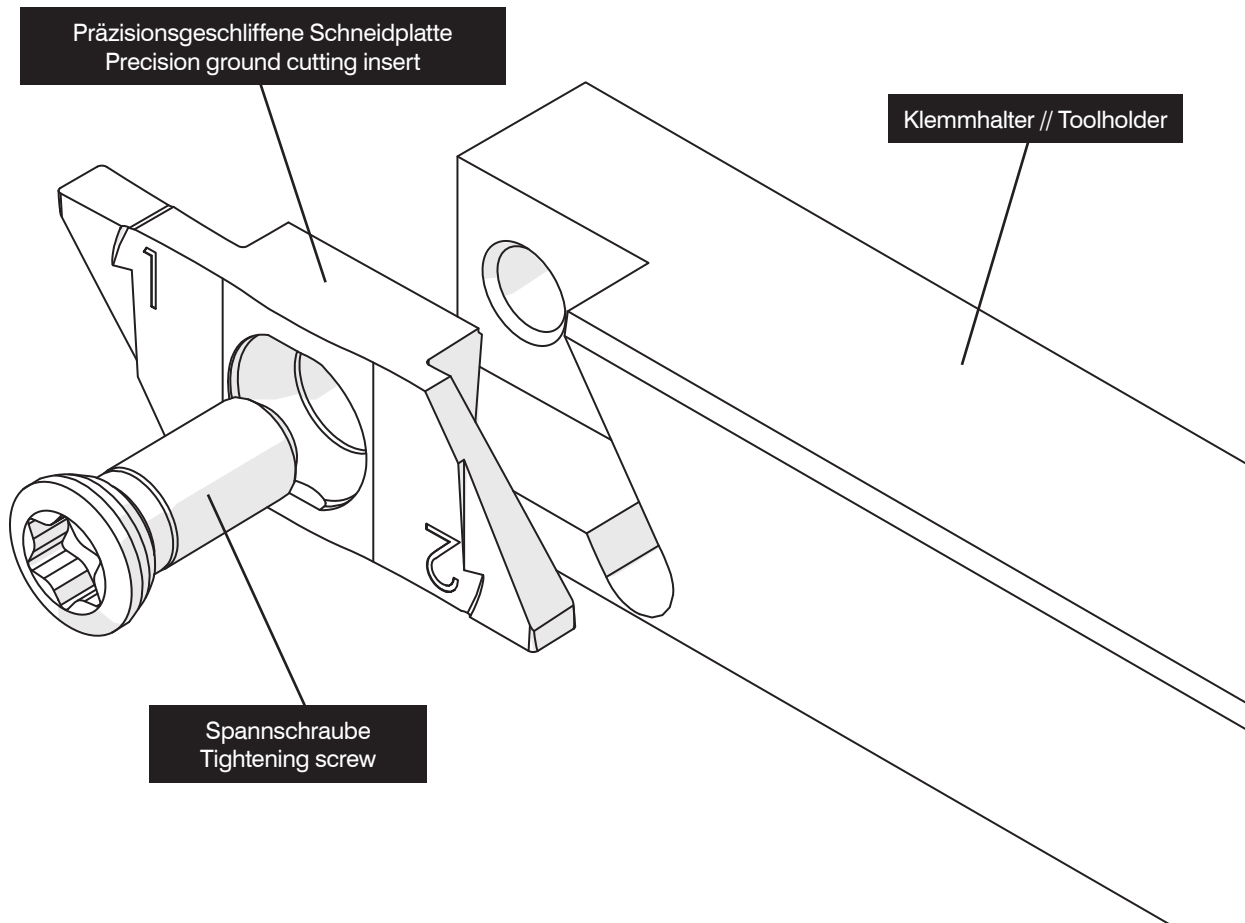
Für die Schnellwechselsysteme „Swiss Micro“ von Swiss Tools und „PZturn“ von MAS bietet simturn KX Schnellwechsellköpfe für einen schnellen und einfachen Werkzeugwechsel auf Langdrehern und Mehrspindeldrehautomaten.

For the quick-change systems „Swiss Micro“ from Swiss Tools and „PZturn“ by the company MAS, simturn KX offers toolholders for a quick and easy tool change on sliding head machined and multi-spindle lathes.

Das System im Detail The system details

Bitte beachten Sie die allgemeinen Gebrauchshinweise auf Seite
Please read the general instructions for use on page

433



Das Werkzeugsystem simturn K2 ist mit seinem zweischneidigen Wendeschneidplatten-Design und Schaftquerschnitten ab 10,0 x 10,0 mm ideal ausgelegt für die Kleinteilebearbeitung außen.

Dabei bietet das System Standardwerkzeuge für alle gängigen Anwendungen und Stechtiefen bis 7,0 mm.

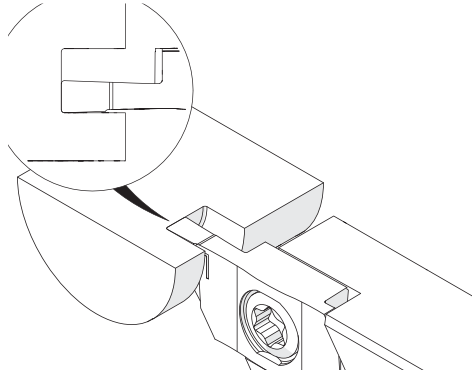
The tool system simturn K2 was designed to meet highest expectations in small part machining. The system provides two-edged indexable cutting inserts and square shank sizes from 10,0 x 10,0 mm on.

All the major applications are available as standard items providing cutting depths up to 7,0 mm.

Standardanwendungen Standard Applications

Ab Seite
 As of page

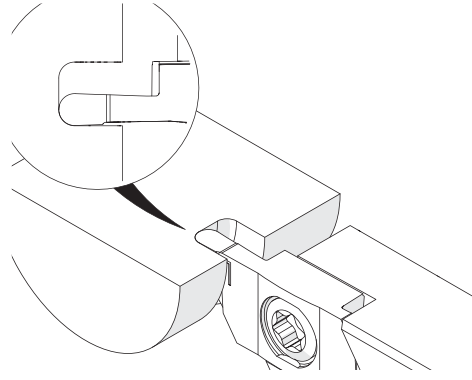
260



Einstecken und Profildrehen
 Grooving and Profiling

Ab Seite
 As of Page

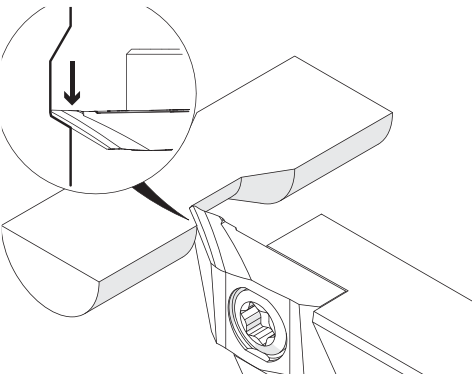
262



Einstecken und Profildrehen, Vollradius
 Grooving and Profiling, Full Radius

Seite
 Page

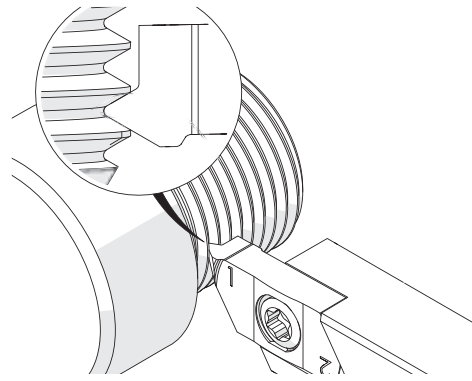
266



Längsdrehen
 Turning

Seite
 Page

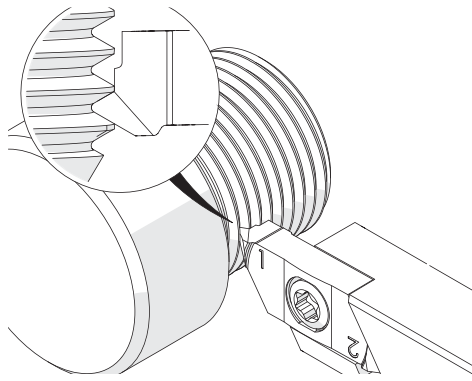
267



Gewinden: Metrisch ISO, Außen, Teilprofil
 Threading: Metric ISO, External, Partial Profile

Seite
 Page

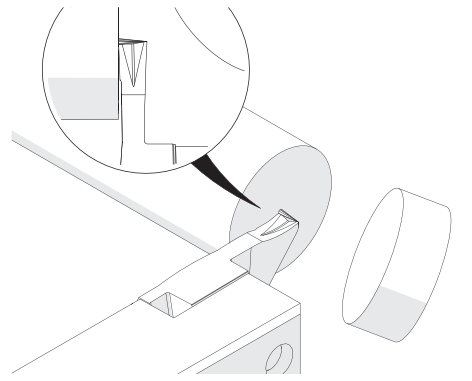
268



Gewinden: Metrisch ISO, Außen, Vollprofil
 Threading: Metric ISO, External, Full Profile

Seite
 Page

269



Abstechen
 Parting Off

Klemmhalter, Außen

Klemmhalter für die Kleinteilebearbeitung.

Toolholder, External

Toolholder for small part machining.

Anzugsmoment (Schraube) // Tightening torque (screw)

"M M3,5x11 T10F": 3,0 Nm
"M M3,5x9 T10F": 3,0 Nm



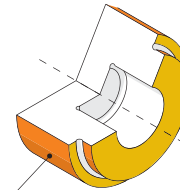
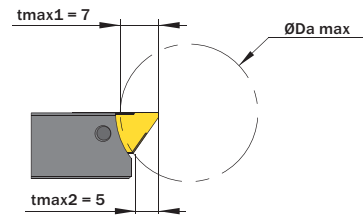
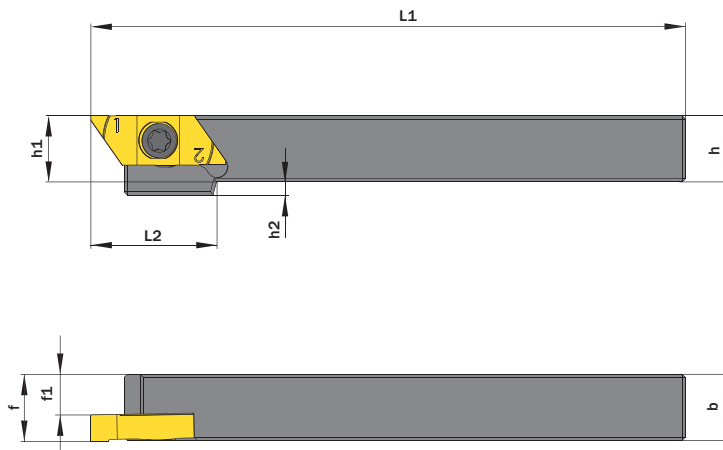
TW
ST **R**

Legende
Legend **272**



Scan
QR-Code

Oder besuchen Sie // Or Visit
www.simtek.info/cp/1108



- Hauptsächlich geeignet für diese Flächen
Mainly designed for these surfaces
- Je nach Schneidplatte/Aufnahme ebenfalls möglich
Also possible depending on insert/fixation type

Abbildung zeigt / Drawing shows: TK2.G.1010.A.14.04 R

h	b	L1	Artikelnummer Part number	Webcode www.simtek.com/webcode	f	f1	h1	h2	L2	ØDa max	Schraube Screw	Schraubenschlüssel Screw driver	Connectcode www.simtek.com/code
mm	mm	mm			mm	mm	mm	mm	mm	mm			
▼ h = 9,525 mm													
9,525	9,525	140,0	TK2.G.0.375.A.14.04 R	A22E	9,72	5,72	9,52	2,0	19,0	20,0	M M3,5x9 T10F	T10F	TK2.G.R.04
▼ h = 10,0 mm													
10,0	10,0	140,0	TK2.G.1010.A.14.04 R/L	R AYQ L AYGS	10,2	6,2	10,0	2,0	19,0	20,0	M M3,5x9 T10F	T10F	R TK2.G.R.04 L TK2.G.L.04
▼ h = 12,0 mm													
12,0	12,0	140,0	TK2.G.1212.A.14.04 R/L	R AYGK L AYG M	12,2	8,2	12,0	-	-	25,0	M M3,5x11 T10F	T10F	R TK2.G.R.04 L TK2.G.L.04
▼ h = 12,7 mm													
12,7	12,7	140,0	TK2.G.0.500.A.14.04 R/L	R A1DK L A1DH	12,9	8,9	12,7	-	-	32,0	M M3,5x11 T10F	T10F	R TK2.G.R.04 L TK2.G.L.04 ^{upd} _{inch}
▼ h = 15,875 mm													
15,875	15,875	140,0	TK2.G.0.625.A.14.04 R/L	R A1DN L A1DM	16,08	12,08	15,88	-	-	32,0	M M3,5x11 T10F	T10F	R TK2.G.R.04 L TK2.G.L.04 ^{upd} _{inch}
▼ h = 16,0 mm													
16,0	16,0	140,0	TK2.G.1616.A.14.04 R/L	R AYGF L AYG G	16,2	12,2	16,0	-	-	32,0	M M3,5x11 T10F	T10F	R TK2.G.R.04 L TK2.G.L.04

Bestellbeispiel // Order example: **TK2.G.1212.A.14.04 R** (R = Rechte Ausführung // Right hand version)

Schnellwechselköpfe, geeignet für „Swiss Micro“

Schnellwechselköpfe geeignet für das Schnellwechselsystem „Swiss Micro“ von Swisstools. Passend auf Grundhalter mit der Schnittstelle „LV3“ und Grundhalter „TOS“ der Marke precium.

Toolholders, suitable for „Swiss Micro“

Toolholders suitable for the quick-change system „Swiss Micro“ by Swisstools. Compatible for base toolholders with interface “LV3” and base toolholders „TOS“ by precium.

Anzugsmoment (Schraube) // Tightening torque (screw)

3,0 Nm



Legende
 Legend **272**

Scan
 QR-Code

Oder besuchen Sie // Or Visit
www.simtek.info/cp/1339

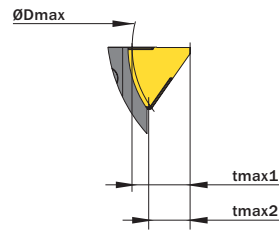
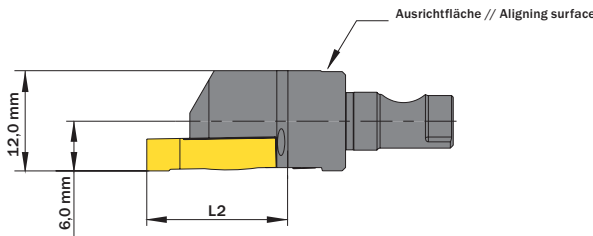
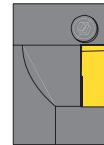
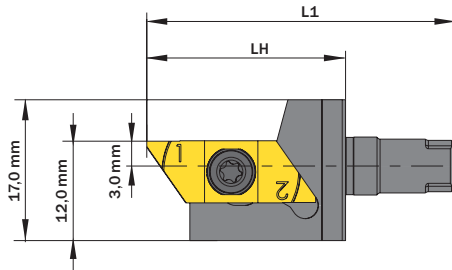


Abbildung zeigt / Drawing shows: TOS.K.TK2.G.01A.IC R

LH	L2	tmax1	Artikelnummer Part number	Webcode www.simtek.com/webcode	L1	tmax2	ØDmax	Schraube Screw	Connectcode www.simtek.com/ccode
mm	mm	mm			mm	mm	mm		
24,0	17,0	7,0	TOS.K.TK2.G.01A.IC R/L	R A48Q L A48V	37,0	5,0	25,0	MM3,5x11 T10F	R TK2.G.R.04 L TK2.G.L.04 new

Bestellbeispiel // Order example: **TOS.K.TK2.G.01A.IC R** (R = Rechte Ausführung // Right hand version)

Schnellwechselköpfe, geeignet für „PZturn“

Schnellwechselköpfe geeignet für das Schnellwechselsystem „PZturn“ der Firma MAS. Passend auf Grundhalter mit der Schnittstelle „PZ12“.

Toolholders, suitable for „PZturn“

Toolholders suitable for the quick-change system „PZturn“ by the company MAS. Compatible for base toolholders with interface „PZ12“.

Anzugsmoment (Schraube) // Tightening torque (screw)

3,0 Nm



Legende
Legend **272**



Scan
QR-Code

Oder besuchen Sie // Or Visit
www.simtek.info/cp/1340

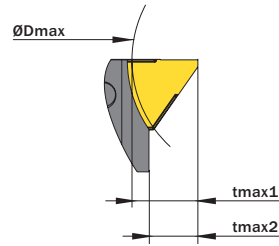
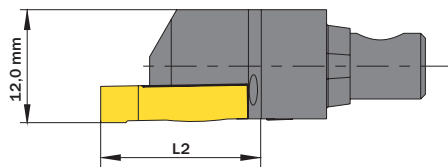
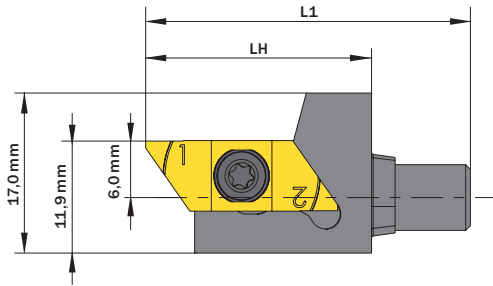


Abbildung zeigt / Drawing shows: TOS.K.TK2.G.1AA.IC R

LH	L2	tmax1	Artikelnummer Part number	Webcode www.simtek.com/webcode		L1	tmax2	ØDmax	Schraube Screw	Connectcode www.simtek.com/ccode				
mm	mm	mm		R	A56B	L	A56D	mm		mm	mm	R	TK2.G.R.04	L
24,0	17,0	7,0	TOS.K.TK2.G.1AA.IC R/L			34,5	5,0	25,0	MM3,5x11 T10F					new

Bestellbeispiel // Order example: **TOS.K.TK2.G.1AA.IC R** (R = Rechte Ausführung // Right hand version)

Einstecken und Profildrehen

CNC-Konturdrehen, universelle Schneidengeometrie für die Bearbeitung eines breiten Materialspektrums.

Grooving and Profiling

CNC profiling, with general cutting edge geometry for a wide variety of workpiece materials.

Schnittwerte (Start) // Cutting parameters (start)

f	Vc
0,02 mm/U	Seite/Page 429

Passende Klemmhalter auf Seite // Suitable toolholders on page 257, 258, 259

SP
HM

R

○

Legende
Legend 272

Scan QR-Code Oder besuchen Sie // Or Visit
www.simtek.info/cp/1115

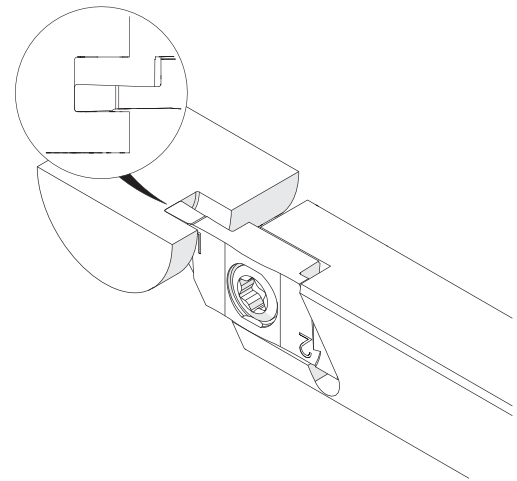
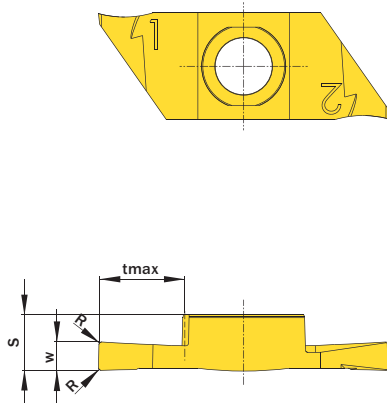


Abbildung zeigt / Drawing shows: TK2.G.200.020.060 NS R

$w \pm 0,02$	R	tmax	Artikelnummer Part number	Webcode www.simtek.com/webcode	Unsere erste Wahl Our first choice	S	Connectcode www.simtek.com/ccode
mm	mm	mm			P K M N S	mm	
0,5	0,05	2,5	TK2.G.050.005.025 NS R/L	R AYHA L AYG9	X808 X408	3,8	R TK2.G.R.04 L TK2.G.L.04
0,75	0,05	3,75	TK2.G.075.005.038 NS R/L	R AYG7 L AYG8	X808 X408	3,8	R TK2.G.R.04 L TK2.G.L.04
1,0	0,05	5,0	TK2.G.100.005.050 NS R/L	R AYG6 L AYG5	X808 X408	3,8	R TK2.G.R.04 L TK2.G.L.04
1,5	0,05	4,5	TK2.G.150.005.045 NS R/L	R A07B L A07A	X808 X408	3,85	R TK2.G.R.04 L TK2.G.L.04
1,5	0,2	4,5	TK2.G.150.020.045 NS R/L	R AYG4 L AYG3	X808 X408	3,85	R TK2.G.R.04 L TK2.G.L.04
2,0	0,05	6,0	TK2.G.200.005.060 NS R/L	R A07D L A07C	X808 X408	3,9	R TK2.G.R.04 L TK2.G.L.04
2,0	0,2	6,0	TK2.G.200.020.060 NS R/L	R AYG2 L AYG1	X808 X408	3,9	R TK2.G.R.04 L TK2.G.L.04
2,5	0,1	7,0	TK2.G.250.010.070 NS R/L	R A07F L A07E	X808 X408	3,9	R TK2.G.R.04 L TK2.G.L.04
2,5	0,2	7,0	TK2.G.250.020.070 NS R/L	R AYG0 L AYGZ	X808 X408	3,9	R TK2.G.R.04 L TK2.G.L.04
3,0	0,1	7,0	TK2.G.300.010.070 NS R/L	R A07H L A07G	X808 X408	3,9	R TK2.G.R.04 L TK2.G.L.04
3,0	0,2	7,0	TK2.G.300.020.070 NS R/L	R AYG Y L AYGX	X808 X408	3,9	R TK2.G.R.04 L TK2.G.L.04

Bestellbeispiel // Order example: **TK2.G.100.005.050 NS R X808** (R = Rechte Ausführung // Right hand version, X808 = Schneidstoff // Grade)

Einstecken und Profildrehen

CNC-Konturdrehen, spezielle Schneidengeometrie für die Bearbeitung von Messing, Kupferlegierungen und anderen kurzspanenden Werkstoffen.

Grooving and Profiling

CNC Profiling, with special cutting edge geometry for brass, copper-based alloys and short-chipping materials.

Schnittwerte (Start) // Cutting parameters (start)

f	Vc
0,02 mm/U	Seite/Page 429

Passende Klemhalter auf Seite // Suitable toolholders on page 257, 258, 259

	SP	HM	R	CU		Legende Legend	272
	Scan QR-Code		Oder besuchen Sie // Or Visit www.simtek.info/cp/1116				

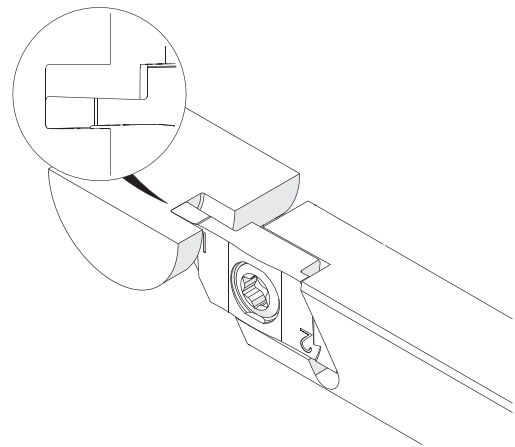
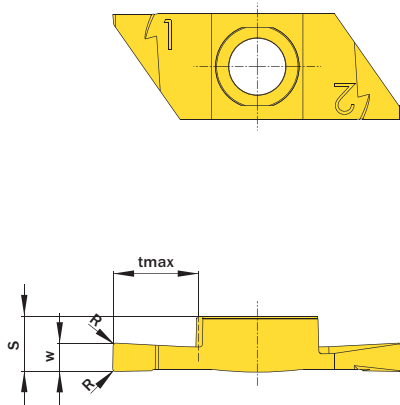


Abbildung zeigt / Drawing shows: TK2.G.200.020.060 NU R

w ±0,02 mm	R mm	tmax mm	Artikelnummer Part number	Webcode www.simtek.com/webcode		Unsere erste Wahl Our first choice		S mm	Connectcode www.simtek.com/ccode	
				P	K	M	N		S	R
0,5	0,05	2,5	TK2.G.050.005.025 NU R/L	R AYHB	L AYHC	X808	X408	3,8	R TK2.G.R.04	L TK2.G.L.04
0,75	0,05	3,75	TK2.G.075.005.038 NU R/L	R AYHD	L AYHE	X808	X408	3,8	R TK2.G.R.04	L TK2.G.L.04
1,0	0,05	5,0	TK2.G.100.005.050 NU R/L	R AYHG	L AYHF	X808	X408	3,8	R TK2.G.R.04	L TK2.G.L.04
1,5	0,05	4,5	TK2.G.150.005.045 NU R/L	R A07K	L A07J	X808	X408	3,85	R TK2.G.R.04	L TK2.G.L.04
1,5	0,2	4,5	TK2.G.150.020.045 NU R/L	R AYHJ	L AYHH	X808	X408	3,85	R TK2.G.R.04	L TK2.G.L.04
2,0	0,05	6,0	TK2.G.200.005.060 NU R/L	R A07N	L A07M	X808	X408	3,9	R TK2.G.R.04	L TK2.G.L.04
2,0	0,2	6,0	TK2.G.200.020.060 NU R/L	R AYHK	L AYHM	X808	X408	3,9	R TK2.G.R.04	L TK2.G.L.04
2,5	0,1	7,0	TK2.G.250.010.070 NU R/L	R A07Q	L A07P	X808	X408	3,9	R TK2.G.R.04	L TK2.G.L.04
2,5	0,2	7,0	TK2.G.250.020.070 NU R/L	R AYHN	L AYHP	X808	X408	3,9	R TK2.G.R.04	L TK2.G.L.04
3,0	0,1	7,0	TK2.G.300.010.070 NU R/L	R A07T	L A07S	X808	X408	3,9	R TK2.G.R.04	L TK2.G.L.04
3,0	0,2	7,0	TK2.G.300.020.070 NU R/L	R AYHS	L AYHQ	X808	X408	3,9	R TK2.G.R.04	L TK2.G.L.04

Bestellbeispiel // Order example: **TK2.G.300.020.070 NU R X808** (R = Rechte Ausführung // Right hand version, X808 = Schneidstoff // Grade)

Einstecken und Profildrehen, Vollradius

Vollradiusnuten, CNC-Konturdrehen. Spezielle Schneidengeometrie für Messing, Kupferlegierungen und andere kurzspanende Werkstoffe.


Grooving and Profiling, Full Radius


Full radius, CNC profiling. Special cutting edge geometry for brass, copper-base alloys and short-chipping materials.

Schnittwerte (Start) // Cutting parameters (start)

f	Vc
0,02 mm/U	Seite/Page 429

Passende Klemmhalter auf Seite // Suitable toolholders on page
257, 258, 259


SP
HM
R
CU
 Legende Legend **272**

 Scan QR-Code
 Oder besuchen Sie // Or Visit www.simtek.info/cp/1109

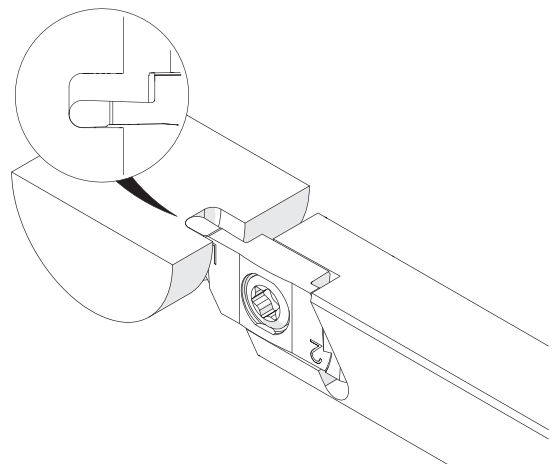
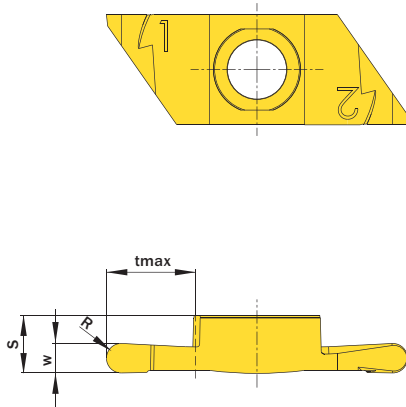


Abbildung zeigt / Drawing shows: TK2.G.200.100.060 VU R

w ±0,02	R	tmax	Artikelnummer Part number	Webcode www.simtek.com/webcode	Unsere erste Wahl Our first choice	S	Connectcode www.simtek.com/ccode
mm	mm	mm			P K M N S	mm	
1,0	0,5	3,0	TK2.G.100.050.030 VU R/L	R AYE8 L AYE9	X808 X408	3,87	R TK2.G.R.04 L TK2.G.L.04
1,2	0,6	3,6	TK2.G.120.060.036 VU R/L	R AYFA L AYFB	X808 X408	3,92	R TK2.G.R.04 L TK2.G.L.04
1,6	0,8	4,8	TK2.G.160.080.048 VU R/L	R AYFD L AYFC	X808 X408	3,92	R TK2.G.R.04 L TK2.G.L.04
2,0	1,0	6,0	TK2.G.200.100.060 VU R/L	R AYFF L AYFE	X808 X408	3,92	R TK2.G.R.04 L TK2.G.L.04

Bestellbeispiel // Order example: **TK2.G.200.100.060 VU R X808** (R = Rechte Ausführung // Right hand version, X808 = Schneidstoff // Grade)

Einstecken und Profildrehen, Vollradius

Vollradiusnuten, CNC-Konturdrehen. Universelle Schneidengeometrie für die Bearbeitung eines breiten Materialspektrums.

Grooving and Profiling, Full Radius

Full radius, CNC profiling. With general cutting edge geometry for a wide variety of workpiece materials.

Schnittwerte (Start) // Cutting parameters (start)

f	Vc
0,02 mm/U	Seite/Page 429

Passende Klemhalter auf Seite // Suitable toolholders on page 257, 258, 259

SP
HM

R

○

Legende
Legend **272**

Scan
QR-Code

Oder besuchen Sie // Or Visit
www.simtek.info/cp/1117

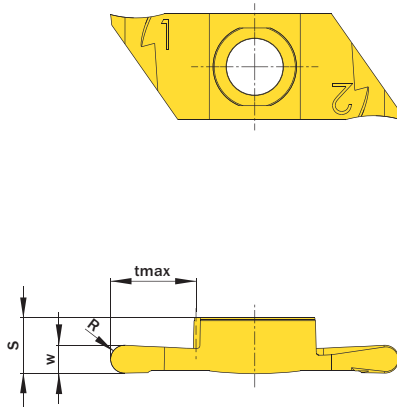
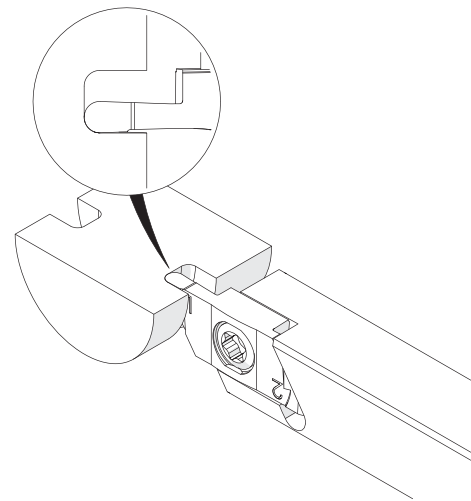


Abbildung zeigt / Drawing shows: TK2.G.200.100.060 VS R



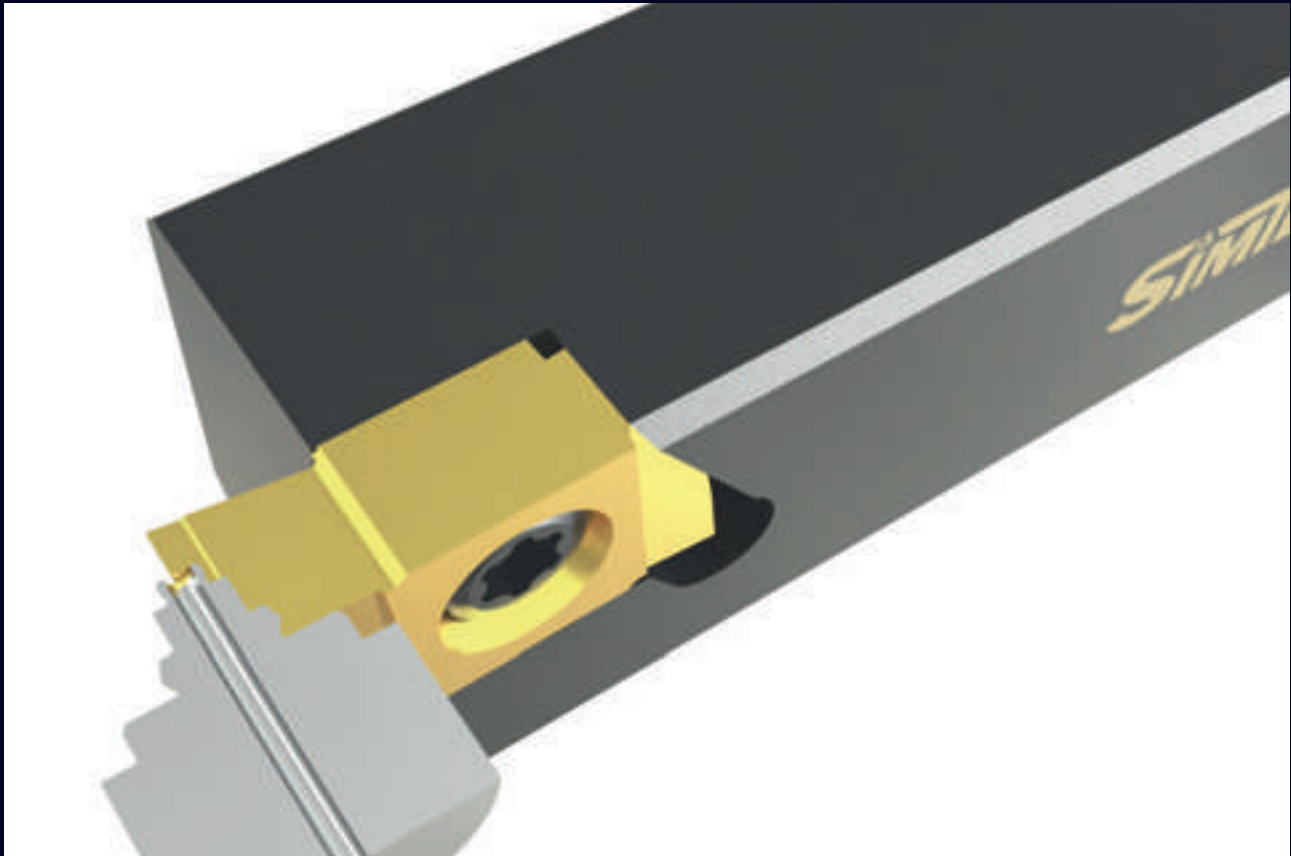
$w \pm 0,02$	R	tmax	Artikelnummer Part number	Webcode www.simtek.com/webcode	Unsere erste Wahl Our first choice	S	Connectcode www.simtek.com/ccode
mm	mm	mm			P K M N S	mm	
1,0	0,5	3,0	TK2.G.100.050.030 VS R/L	R AYH0 L AYHZ	X808 X408	3,87	R TK2.G.R.04 L TK2.G.L.04
1,2	0,6	3,6	TK2.G.120.060.036 VS R/L	R AYHY L AYHX	X808 X408	3,92	R TK2.G.R.04 L TK2.G.L.04
1,6	0,8	4,8	TK2.G.160.080.048 VS R/L	R AYHV L AYHW	X808 X408	3,92	R TK2.G.R.04 L TK2.G.L.04
2,0	1,0	6,0	TK2.G.200.100.060 VS R/L	R AYHT L AYHU	X808 X408	3,92	R TK2.G.R.04 L TK2.G.L.04

Bestellbeispiel // Order example: **TK2.G.100.050.030 VS R X808** (R = Rechte Ausführung // Right hand version, X808 = Schneidstoff // Grade)

simturn AX
simturn DX
simturn PX
simturn H2
simturn K2
simturn C4
simturn GX
simturn E3
simturn E12
simturn FX
simturn Decolletage
simturn OA
Index

Individualwerkzeuge // Customized tools

Kundenindividuelle Werkzeuglösungen Customer-specific tooling solutions



Herstellen einer breiten Außenkontur mit hohen Anforderungen an Toleranzen an einem kleinen Bauteil. simturn KX ist dank Schaftabmessungen ab 10x10mm ideal ausgelegt für die Kleinteilebearbeitung außen.

SIMTEK Individualwerkzeuge bieten unzählige Vorteile! Neben unserem Anspruch, jeweils die qualitativ bestmögliche Werkzeuglösung für Ihre Anwendung anzubieten, ist es auch unser Bestreben Ihnen durch ein SIMTEK Individualwerkzeug den größtmöglichen wirtschaftlichen Nutzen zu liefern! Tausende, aktuell erfolgreich eingesetzte Individualwerkzeuge bestätigen dies!

Kontaktieren Sie uns und lassen auch Sie sich von den Vorteilen mit SIMTEK Individualwerkzeugen überzeugen!

Manufacturing of a wide external contour with high demands on tolerances on a small component. simturn KX is ideally designed for the external machining of small parts thanks to shaft dimensions starting at 10x10mm.

SIMTEK individual tools offer countless advantages! In addition to our goal to offer the qualitatively best possible tooling solution for your application, we also aspire to provide you with the greatest possible economic benefit from a customized SIMTEK tool! Thousands of currently successfully used SIMTEK individual tools confirm this!

Contact us and convince yourself of the advantages of SIMTEK individual tools!

simturnKX
SIMTEK small part machining type KX

Einstecken und Längsdrehen

Zwei auf der Drehmitte liegende Schneiden sorgen dank geschliffener Schneidengeometrie für höchste Präzision beim Einstecken und Längsdrehen mit einem Werkzeug. Optimale Spanabfuhr führt zu hoher Oberflächengüte.

Grooving and turning

The ground geometry of two cutting edges, that are directly on the rotation centre, ensure highest precision for grooving and turning applications with one tool. Optimum chip removal leads to high surface quality.

Schnittwerte (Start) // Cutting parameters (start)	
f 0,02 mm/U	Vc Seite/Page 429

Passende Klemhalter auf Seite // Suitable toolholders on page
257, 258, 259

SP

HM

R

Legende
Legend **272**

Scan
QR-Code

Oder besuchen Sie // Or Visit
www.simtek.info/cp/1272

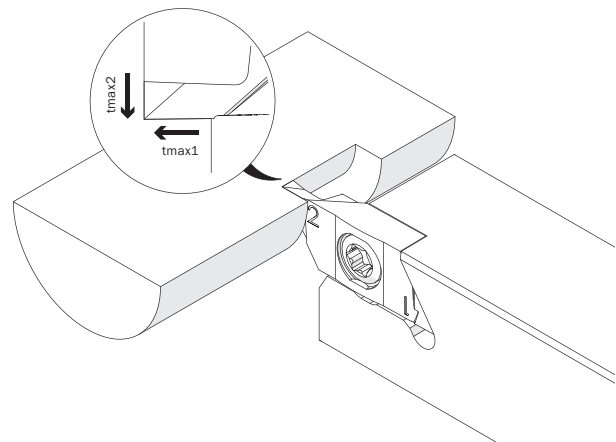
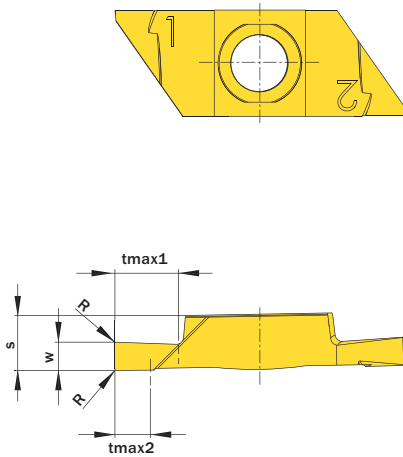


Abbildung zeigt / Drawing shows: TK2.G.R200.005 YP R

w	R	Artikelnummer Part number	Webcode www.simtek.com/webcode	Unsere erste Wahl Our first choice	tmax1	tmax2	S	Connectcode www.simtek.com/code
mm	mm			P K M N S	mm	mm	mm	
▼ w = 1,0 mm								
1,0	-	TK2.G.R100.000 YP R	A14G	X808 X408	2,5	2,5	3,8	TK2.G.R.04
1,0	0,05	TK2.G.R100.005 YP R	A14H	X808 X408	2,5	2,5	3,8	TK2.G.R.04
▼ w = 1,5 mm								
1,5	0,05	TK2.G.R150.005 YP R	A14J	X808 X408	3,75	2,5	3,8	TK2.G.R.04
1,5	0,1	TK2.G.R150.010 YP R	A14K	X808 X408	3,75	2,5	3,8	TK2.G.R.04
▼ w = 2,0 mm								
2,0	0,05	TK2.G.R200.005 YP R	A14M	X808 X408	4,5	2,5	3,8	TK2.G.R.04
2,0	0,1	TK2.G.R200.010 YP R	A14N	X808 X408	4,5	2,5	3,8	TK2.G.R.04
2,0	0,2	TK2.G.R200.020 YP R	A14P	X808 X408	4,5	2,5	3,8	TK2.G.R.04

Bestellbeispiel // Order example: **TK2.G.R200.020 YP R X808** (R = Rechte Ausführung // Right hand version, X808 = Schneidstoff // Grade)

Längsdrehen

Für das Längsdrehen bzw. Rückwärtsdrehen „hinter Bund“.

Turning

For turning as well as for back turning „behind shoulder“.

Schnittwerte (Start) // Cutting parameters (start)

f	Vc
0,05 mm/U	Seite/Page 429

Passende Klemmhalter auf Seite // Suitable toolholders on page
257, 258, 259






 Legende Legend 272
 Oder besuchen Sie // Or Visit www.simtek.info/cp/1110

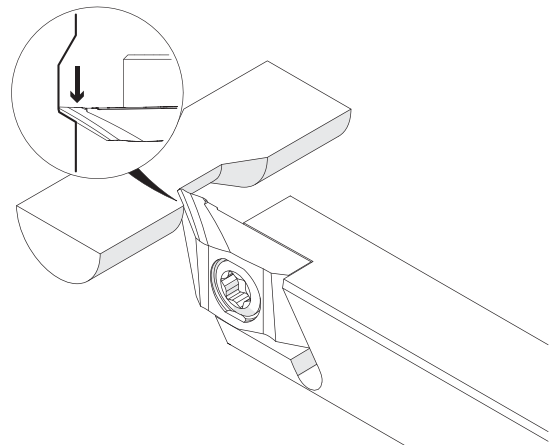
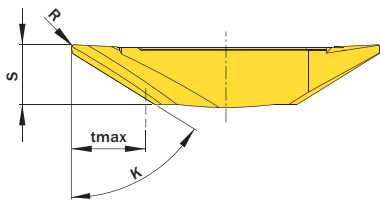
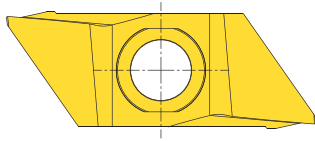


Abbildung zeigt / Drawing shows: TK2.G.059.02.06.20 YY R

K	tmax	R	Artikelnummer Part number	Webcode www.simtek.com/webcode		Unsere erste Wahl Our first choice		S mm	Connectcode www.simtek.com/ccode	
	mm	mm		P	K	M	N		S	R
59°	5,0	0,05	TK2.G.059.02.05.05 YYR/L	R A2BE	L A2BF	X808	X408	3,95	R TK2.G.R.04	L TK2.G.L.04
59°	5,0	0,1	TK2.G.059.02.05.10 YYR/L	R A150	L A153	X808	X408	3,95	R TK2.G.R.04	L TK2.G.L.04
59°	5,0	0,2	TK2.G.059.02.05.20 YYR/L	R AYFH	L AYFJ	X808	X408	3,95	R TK2.G.R.04	L TK2.G.L.04
59°	5,0	0,4	TK2.G.059.02.05.40 YYR/L	R AYFM	L AYFK	X808	X408	3,95	R TK2.G.R.04	L TK2.G.L.04

Bestellbeispiel // Order example: **TK2.G.059.02.05.20 YYR X808** (R = Rechte Ausführung // Right hand version, X808 = Schneidstoff // Grade)

Längsdrehen, mit Spantreppe Typ „E“

Typ „E“ Spantreppe, für optimale Leistung und Spanbildung.

Turning, Cutting Edge Design „E“

Cutting Edge Design „E“, for high performance and chip control.

Schnittwerte (Start) // Cutting parameters (start)

f	Vc
0,05 mm/U	Seite/Page 429

Passende Klemmhalter auf Seite // Suitable toolholders on page
257, 258, 259

SP

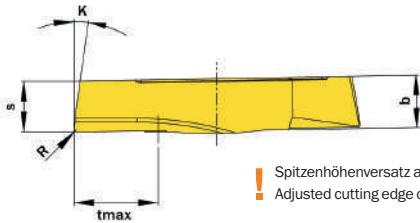
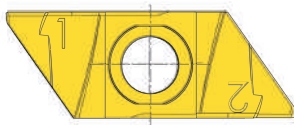
HM

R

Legende
Legend **273**

Scan
QR-Code

Oder besuchen Sie // Or Visit
www.simtek.info/cp/1242



Spitzenhöhenversatz aufgrund der speziellen Spantreppe.
Adjusted cutting edge center height due to special chip former.

Abbildung zeigt / Drawing shows: TK2.G.008.10.020 YE R

K	R mm	Artikelnummer Part number	Webcode www.simtek.com/webcode	Unsere erste Wahl Our first choice					B mm	S mm	tmax mm	Connectcode www.simtek.com/code
				P	K	M	N	S				
8°	0,05	TK2.G.008.10.005 YE R/L	R BEE6 L BEE4	X808	X408				3,7	3,6	6,0	R TK2.G.R.04 L TK2.G.L.04
8°	0,1	TK2.G.008.10.010 YE R/L	R BEE2 L BEE0	X808	X408				3,7	3,6	6,0	R TK2.G.R.04 L TK2.G.L.04
8°	0,2	TK2.G.008.10.020 YE R/L	R A01Z L A01Y	X808	X408				3,7	3,6	6,0	R TK2.G.R.04 L TK2.G.L.04
30°	0,05	TK2.G.030.10.005 YE R/L	R BEFA L BEE8	X808	X408				3,7	3,6	6,0	R TK2.G.R.04 L TK2.G.L.04
30°	0,1	TK2.G.030.10.010 YE R/L	R BEFE L BEFC	X808	X408				3,7	3,6	6,0	R TK2.G.R.04 L TK2.G.L.04
30°	0,2	TK2.G.030.10.020 YE R/L	R A01W L A01X	X808	X408				3,7	3,6	6,0	R TK2.G.R.04 L TK2.G.L.04
50°	0,05	TK2.G.050.10.005 YE R/L	R BEFJ L BEFG	X808	X408				3,7	3,6	6,0	R TK2.G.R.04 L TK2.G.L.04
50°	0,1	TK2.G.050.10.010 YE R/L	R BEFP L BEFM	X808	X408				3,7	3,6	6,0	R TK2.G.R.04 L TK2.G.L.04
50°	0,2	TK2.G.050.10.020 YE R/L	R A01V L A01U	X808	X408				3,7	3,6	6,0	R TK2.G.R.04 L TK2.G.L.04

Bestellbeispiel // Order example: **TK2.G.030.10.020 YE R X808** (R = Rechte Ausführung // Right hand version, X808 = Schneidstoff // Grade)

Gewindedrehen, Metr. ISO, Außen, Teilprofil

Mehrbereichswerkzeuge für verschiedene Steigungen.
Spezielle Schneidengeometrie für Messing, Kupferlegierungen
und andere kurzspanende Werkstoffe.

Threading, Metr. ISO, External, Partial Profile

Multi-purpose tools, usable for different pitches. Special cutting edge
geometry for brass, copper-base alloys and short-chipping materials.




Schnittwerte (Start) // Cutting parameters (start)


f **0,02 mm/U** Vc **Seite/Page 429**


Empf. Zustellungsart // Recom. infeed method
Flankenzustellung // Flank infeed (Seite/Page 433)

Passende Klemmhalter auf Seite // Suitable toolholders on page
257, 258, 259

Bitte Hinweise im Anhang beachten // Please read add. notes
T01 (Seite/Page 271)


 Legende
Legend **272**

 Scan
QR-Code
 Oder besuchen Sie // Or Visit
www.simtek.info/cp/1132

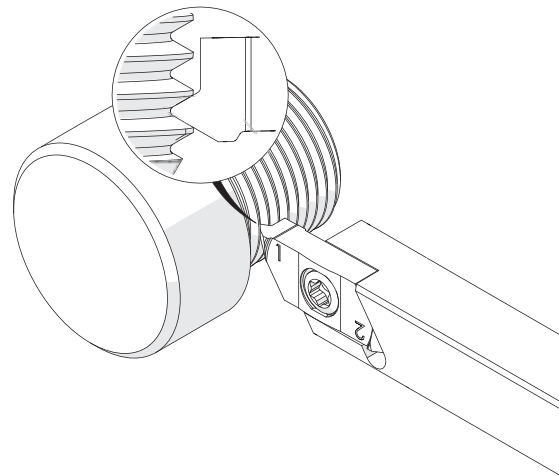
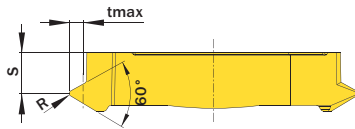
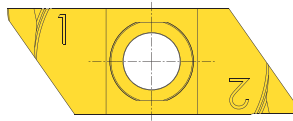


Abbildung zeigt / Drawing shows: TK2.G.M150.01 EMU R

Steigung (von) Pitch (as of)	Steigung (bis) Pitch (up to)	Artikelnummer Part number	Webcode www.simtek.com/webcode	Unsere erste Wahl Our first choice					R	S	tmax	Connectcode www.simtek.com/ccode
				P	K	M	N	S				
0,25	0,45	TK2.G.M025.01 EMU R/L	R AYK9 L AYK8	X808	X408				0,04	3,4	0,3	R TK2.G.R.04 L TK2.G.L.04
0,4	0,6	TK2.G.M040.01 EMU R/L	R AYMD L AYMC	X808	X408				0,06	3,3	0,4	R TK2.G.R.04 L TK2.G.L.04
0,5	0,75	TK2.G.M050.01 EMU R/L	R AYMH L AYMG	X808	X408				0,07	3,2	0,5	R TK2.G.R.04 L TK2.G.L.04
0,7	1,0	TK2.G.M070.01 EMU R/L	R AYMK L AYMJ	X808	X408				0,1	3,1	0,7	R TK2.G.R.04 L TK2.G.L.04
0,8	1,25	TK2.G.M080.01 EMU R/L	R AYMQ L AYMP	X808	X408				0,12	3,1	0,8	R TK2.G.R.04 L TK2.G.L.04
1,0	1,5	TK2.G.M100.01 EMU R/L	R AYMT L AYMS	X808	X408				0,14	3,0	1,0	R TK2.G.R.04 L TK2.G.L.04
1,25	1,75	TK2.G.M125.01 EMU R/L	R AYMV L AYMU	X808	X408				0,18	2,9	1,1	R TK2.G.R.04 L TK2.G.L.04
1,5	2,0	TK2.G.M150.01 EMU R/L	R AYMX L AYMW	X808	X408				0,22	2,8	1,3	R TK2.G.R.04 L TK2.G.L.04
1,75	2,5	TK2.G.M175.01 EMU R/L	R AYUU L AYUT	X808	X408				0,25	2,7	1,6	R TK2.G.R.04 L TK2.G.L.04
2,0	2,5	TK2.G.M200.01 EMU R/L	R AYMZ L AYMY	X808	X408				0,29	2,6	1,6	R TK2.G.R.04 L TK2.G.L.04

Bestellbeispiel // Order example: **TK2.G.M100.01 EMU R X808** (R = Rechte Ausführung // Right hand version, X808 = Schneidstoff // Grade)

Bitte beachten Sie die zusätzlichen Hinweise im Infobereich rechts oben.
Please read the additional notes mentioned in the information area on the top right corner of this page.

simturn AX
simturn DX
simturn PX
simturn H2
simturn K2
simturn C4
simturn GX
simturn E3
simturn E12
simturn FX
simturn Decolletage
simturn OA
Index

Gewindedrehen, Metr. ISO, Außen, Vollprofil

Herstellung des vollständigen Gewindeprofils mit notwendiger Tiefe sowie Kopf- und Fußradien. Spezielle Schneidengeometrie für Messing, Kupferlegierungen und andere kurzspanende Werkstoffe.

Threading, Metr. ISO, External, Full Profile


For a complete thread profile with correct depth, top radius and bottom radius. Special cutting edge geometry for brass, copper-base alloys and short-chipping materials.




Schnittwerte (Start) // Cutting parameters (start)

f	Vc
0,02 mm/U	Seite/Page 429

Empf. Zustellungsart // Recom. infeed method
Flankenzustellung // Flank infeed (Seite/Page 433)

Passende Klemmhalter auf Seite // Suitable toolholders on page
257, 258, 259






 Legende Legend **272**
 Oder besuchen Sie // Or Visit www.simtek.info/cp/1131

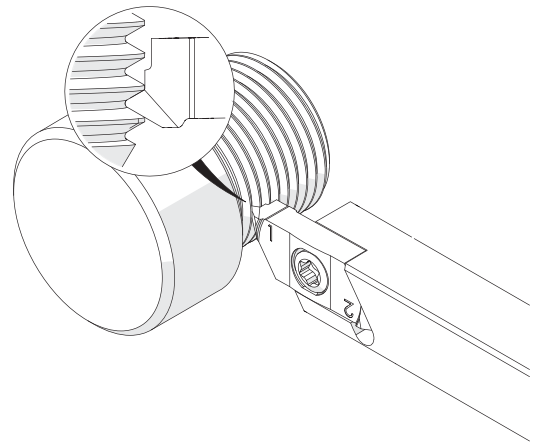
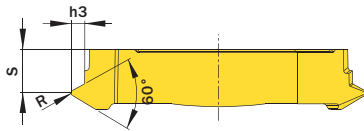
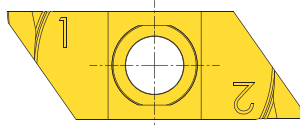


Abbildung zeigt / Drawing shows: TK2.G.M150.02 EMU R

Steigung (von) Pitch (as of)	Artikelnummer Part number	Webcode www.simtek.com/webcode	Unsere erste Wahl Our first choice		h3	R	S	Connectcode www.simtek.com/ccode	
			P	K				M	S
0,25	TK2.G.M025.02 EMU R/L	R AYM5 L AYM4	X808	X408	0,15	0,04	3,6	R TK2.G.R.04	L TK2.G.L.04
0,35	TK2.G.M035.02 EMU R/L	R AYM7 L AYM6	X808	X408	0,22	0,05	3,5	R TK2.G.R.04	L TK2.G.L.04
0,4	TK2.G.M040.02 EMU R/L	R AYM9 L AYM8	X808	X408	0,25	0,06	3,5	R TK2.G.R.04	L TK2.G.L.04
0,45	TK2.G.M045.02 EMU R/L	R AYNB L AYNA	X808	X408	0,28	0,07	3,5	R TK2.G.R.04	L TK2.G.L.04
0,5	TK2.G.M050.02 EMU R/L	R AYND L AYNC	X808	X408	0,31	0,07	3,4	R TK2.G.R.04	L TK2.G.L.04
0,7	TK2.G.M070.02 EMU R/L	R AYNE L AYNF	X808	X408	0,43	0,1	3,3	R TK2.G.R.04	L TK2.G.L.04
0,75	TK2.G.M075.02 EMU R/L	R AYNH L AYNG	X808	X408	0,46	0,11	3,3	R TK2.G.R.04	L TK2.G.L.04
0,8	TK2.G.M080.02 EMU R/L	R AYNK L AYNJ	X808	X408	0,49	0,11	3,3	R TK2.G.R.04	L TK2.G.L.04
1,0	TK2.G.M100.02 EMU R/L	R AYNN L AYNM	X808	X408	0,61	0,12	3,2	R TK2.G.R.04	L TK2.G.L.04
1,25	TK2.G.M125.02 EMU R/L	R AYNQ L AYNP	X808	X408	0,77	0,15	3,1	R TK2.G.R.04	L TK2.G.L.04
1,5	TK2.G.M150.02 EMU R/L	R AYNT L AYNS	X808	X408	0,92	0,2	3,0	R TK2.G.R.04	L TK2.G.L.04
1,75	TK2.G.M175.02 EMU R/L	R AYNV L AYNU	X808	X408	1,07	0,25	2,9	R TK2.G.R.04	L TK2.G.L.04
2,0	TK2.G.M200.02 EMU R/L	R AYNX L AYNW	X808	X408	1,23	0,25	2,8	R TK2.G.R.04	L TK2.G.L.04
2,5	TK2.G.M250.02 EMU R/L	R AYNZ L AYNY	X808	X408	1,53	0,35	2,6	R TK2.G.R.04	L TK2.G.L.04
3,0	TK2.G.M300.02 EMU R/L	R AYN1 L AYN0	X808	X408	1,84	0,4	2,4	R TK2.G.R.04	L TK2.G.L.04

Bestellbeispiel // Order example: **TK2.G.M150.02 EMU R X808** (R = Rechte Ausführung // Right hand version, X808 = Schneidstoff // Grade)

Abstechen

Verfügbar in verschiedenen Winkeln, Breiten und mit/ohne geschliffener Spanformrinne.

Parting Off

Available in different angles, widths and with/without ground chip form channel.

Schnittwerte (Start) // Cutting parameters (start)	
f	Vc
0,02 mm/U	Seite/Page 429

Passende Klemmhalter auf Seite // Suitable toolholders on page
257, 258, 259

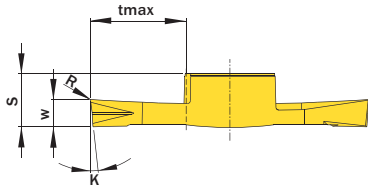
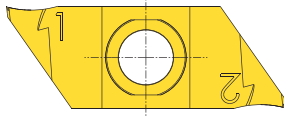
SP
HM

R

Legende
Legend

272

Scan QR-Code Oder besuchen Sie // Or Visit www.simtek.info/cp/1119



Abbildungen ähnlich // Similar illustrations



Bearbeitbare Materialien. Siehe unten.
Machineable materials. See below.

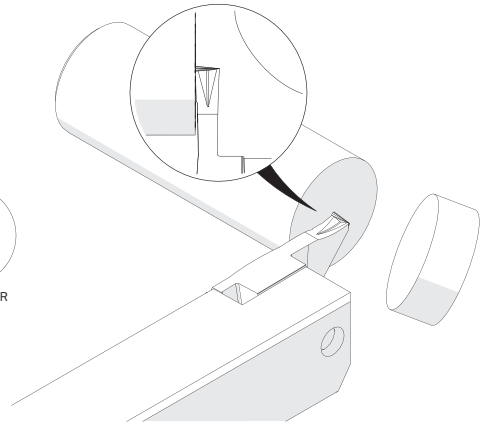


Abbildung zeigt / Drawing shows: TK2.G.R200.06.005 PT R

w ^{-0,05} mm	K	R mm	Mit Spanformrinne With chip form channel	Artikelnummer Part number	Webcode www.simtek.com/webcode	Unsere erste Wahl Our first choice	S mm	tmax mm	Connectcode www.simtek.com/code	
						P K M N S				
▼ w = 1,0 mm										
1,0	6°	0,05	Nein / No	TK2.G.R100.06.005 PS R	AYJQ	X808 X408	3,8	4,0	TK2.G.R.04	
1,0	6°	0,05	Ja / Yes	TK2.G.R100.06.005 PT R	AYJK	X808 X408	3,8	4,0	TK2.G.R.04	
1,0	6°	0,05	Nein / No	TK2.G.R100.06.005 PU R	AYJJ	X808 X408	3,8	4,0	TK2.G.R.04	
1,0	12°	0,05	Nein / No	TK2.G.R100.12.005 PS R	AYJF	X808 X408	3,8	4,0	TK2.G.R.04	
1,0	12°	0,05	Ja / Yes	TK2.G.R100.12.005 PT R	AYJS	X808 X408	3,8	4,0	TK2.G.R.04	
1,0	12°	0,05	Nein / No	TK2.G.R100.12.005 PU R	AYJE	X808 X408	3,8	4,0	TK2.G.R.04	
▼ w = 1,5 mm										
1,5	6°	0,05	Nein / No	TK2.G.R150.06.005 PS R	AYJP	X808 X408	3,8	6,0	TK2.G.R.04	
1,5	6°	0,05	Ja / Yes	TK2.G.R150.06.005 PT R	AYJM	X808 X408	3,8	6,0	TK2.G.R.04	
1,5	6°	0,05	Nein / No	TK2.G.R150.06.005 PU R	AYJH	X808 X408	3,8	6,0	TK2.G.R.04	
1,5	12°	0,05	Nein / No	TK2.G.R150.12.005 PS R	AYJG	X808 X408	3,8	6,0	TK2.G.R.04	
1,5	12°	0,05	Ja / Yes	TK2.G.R150.12.005 PT R	AYJT	X808 X408	3,8	6,0	TK2.G.R.04	
1,5	12°	0,05	Nein / No	TK2.G.R150.12.005 PU R	AYJD	X808 X408	3,8	6,0	TK2.G.R.04	
▼ w = 2,0 mm										
2,0	6°	0,05	Ja / Yes	TK2.G.R200.06.005 PT R	AYJN	X808 X408	3,9	7,0	TK2.G.R.04	
2,0	12°	0,05	Nein / No	TK2.G.R200.12.005 PS R	A6XD	X808 X408	3,9	7,0	TK2.G.R.04 new	
2,0	12°	0,05	Ja / Yes	TK2.G.R200.12.005 PT R	AYJU	X808 X408	3,9	7,0	TK2.G.R.04	

Bestellbeispiel // Order example: TK2.G.R100.12.005 PS R X808 (R = Rechte Ausführung // Right hand version, X808 = Schneidstoff // Grade)

TK2.G.R...PS R: Für die Bearbeitung eines breiten Materialspektrums // For a wide variety of workpiece materials.

TK2.G.R...PU R: Für die Bearbeitung von Messing, Kupferlegierungen und anderen kurzspanenden Werkstoffen. // For brass, copper-based alloys and short-chipping materials

TK2.G.R...PT R: Für die Bearbeitung eines breiten Materialspektrums sowie besonders für Langspanendes Material und hohe Stechtiefen // For a wide variety of workpiece materials as well as especially for long-chipping materials and high cutting depths.

Abstechen

Verfügbar in verschiedenen Breiten.

Parting Off

Available in different widths.

Schnittwerte (Start) // Cutting parameters (start)	
f	Vc
0,02 mm/U	Seite/Page 429

Passende Klemhalter auf Seite // Suitable toolholders on page
257, 258, 259

SP

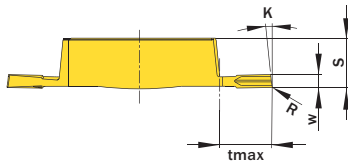
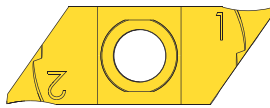
HM

R

Legende
Legend **272**

Scan
QR-Code

Oder besuchen Sie // Or Visit
www.simtek.info/cp/1287



Abbildungen ähnlich // Similar illustrations

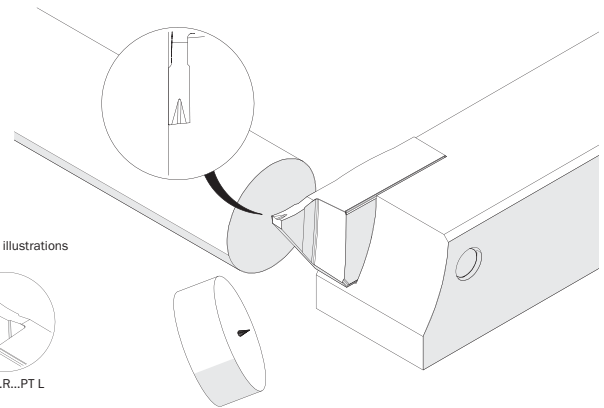


Abbildung zeigt / Drawing shows: TK2.G.R100.06.005 PT L

w ^{-0,05} mm	K	R mm	Mit Spanformille With chip form channel	Artikelnummer Part number	Webcode www.simtek.com/webcode	Unsere erste Wahl Our first choice	S mm	tmax mm	Connectcode www.simtek.com/code
▼ w = 1,0 mm									
1,0	6°	0,05	Ja / Yes	TK2.G.R100.06.005 PT L	A2S0	X808 X408	3,8	4,0	TK2.G.L.04
1,0	12°	0,05	Nein / No	TK2.G.R100.12.005 PS L	AZT2	X808 X408	3,8	4,0	TK2.G.L.04
▼ w = 1,5 mm									
1,5	6°	0,05	Ja / Yes	TK2.G.R150.06.005 PT L	A2S1	X808 X408	3,85	6,0	TK2.G.L.04
1,5	12°	0,05	Nein / No	TK2.G.R150.12.005 PS L	A2WC	X808 X408	3,85	6,0	TK2.G.L.04

Bestellbeispiel // Order example: **TK2.G.R100.12.005 PS L X808** (L = Linke Ausführung // Left hand version, X808 = Schneidstoff // Grade)

- TK2.G.R...PS L: Für die Bearbeitung eines breiten Materialspektrums // For a wide variety of workpiece materials.
- TK2.G.R...PT L: Für die Bearbeitung eines breiten Materialspektrums sowie besonders für langspanendes Material und hohe Stechtiefen // For a wide variety of workpiece materials as well as especially for long-chipping materials and high cutting depths.

Hinweisliste Additional Information

T01

Bei den simturn Teilprofil-Gewindeschneidplatten für metrische ISO-Gewinde handelt es sich um Mehrbereichswerkzeuge, d.h. dass mit einem Werkzeug unterschiedliche Steigungen gefertigt werden können.

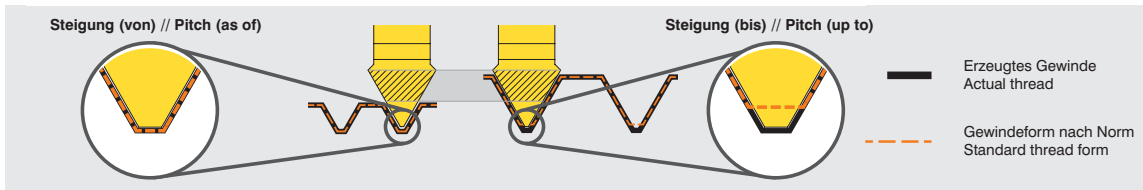
Das Schneidwerkzeug ist dabei immer auf die angegebene „Steigung (von)“ ausgelegt, wodurch ein normgerechtes Gewinde beim Fertigen dieser Steigung entsteht.

Die ebenfalls angegebene „Steigung (bis)“ kann mit diesem Werkzeug ebenfalls gefertigt werden. Es entsteht hierbei jedoch ein - gegenüber der Norm - geringfügig tieferes Gewinde. Die geringfügig höhere Gewindetiefe ist i.d.R. akzeptabel, es muss jedoch immer der Einzelfall beurteilt werden.

The simturn threading inserts with partial profile for metric ISO-threads are multi-purpose tools. This means that each insert is offering the possibility to machine different pitches.

The insert is always designed to meet the pitch given as „Pitch (as of)“: Machining this pitch will result in a standard conform thread form.

The given „Pitch (up to)“ can be machined too with this insert at the expense of standard conformity: The resulting thread will be slightly deeper than the standard. The deeper thread is usually acceptable, but the application and use needs to be evaluated.



Beispiel // Example

Info

Legende
Legend

- SP** Schneidwerkzeug aus Hartmetall // Carbide insert // Outils coupants en carbure de tungstène // Inserto in metallo duro
HM Inserto de carburo // Karbür kesici uç
- TW** Trägerwerkzeug aus Stahl // Steel toolholder // Porte-outils en acier // Porta inserto in acciaio
ST Porta-herramientas de acero // Çelik tutucu
- R** Rechts wie gezeichnet // Right hand version shown, left hand version inversely // A droite comme présenté // In figura utensile destro
 Modelo derecho // Sağ model
- CU** Speziell für Messing, Kupferlegierungen und kurzspanende Materialien // For brass, copper-base alloys and other short-chipping materials // Spécialement pour alliages laiton et cuivre // Per ottone, leghe a base di rame e tutti gli altri materiali a truciolo corto
 Especializado para latón, aleación de cobre y materiales con virutas cortas // Pirinç , Bakır ve kısa talaşlı malzemeler için
- Nur für die Außenbearbeitung geeignet // Only suitable for external applications // Seulement pour opérations extérieures
 Solo per lavorazione esterna // Sólo para mecanizado externo // Dış çaplar için

Index

simturn KX Produktverzeichnis
simturn KX Product List

Artikelnr. // Part Nr.	S/P	Artikelnr. // Part Nr.	S/P	Artikelnr. // Part Nr.	S/P
TK2.G.0.375.A.14.04 R	257	TK2.G.250.010.070 NU R	261	TK2.G.R100.06.005 PT L	270
TK2.G.0.500.A.14.04 L	257	TK2.G.250.020.070 NS L	260	TK2.G.R100.06.005 PT R	269
TK2.G.0.500.A.14.04 R	257	TK2.G.250.020.070 NS R	260	TK2.G.R100.06.005 PU R	269
TK2.G.0.625.A.14.04 L	257	TK2.G.250.020.070 NU L	261	TK2.G.R100.12.005 PS L	270
TK2.G.0.625.A.14.04 R	257	TK2.G.250.020.070 NU R	261	TK2.G.R100.12.005 PS R	269
TK2.G.050.005.025 NS L	260	TK2.G.300.010.070 NS L	260	TK2.G.R100.12.005 PT R	269
TK2.G.050.005.025 NS R	260	TK2.G.300.010.070 NS R	260	TK2.G.R100.12.005 PU R	269
TK2.G.050.005.025 NU L	261	TK2.G.300.010.070 NU L	261	TK2.G.R150.005 YP R	265
TK2.G.050.005.025 NU R	261	TK2.G.300.010.070 NU R	261	TK2.G.R150.010 YP R	265
TK2.G.059.02.05.05 YYL	266	TK2.G.300.020.070 NS L	260	TK2.G.R150.06.005 PS R	269
TK2.G.059.02.05.05 YYR	266	TK2.G.300.020.070 NS R	260	TK2.G.R150.06.005 PT L	270
TK2.G.059.02.05.10 YYL	266	TK2.G.300.020.070 NU L	261	TK2.G.R150.06.005 PT R	269
TK2.G.059.02.05.10 YYR	266	TK2.G.300.020.070 NU R	261	TK2.G.R150.06.005 PU R	269
TK2.G.059.02.05.20 YYL	266	TK2.G.M025.01 EMU L	267	TK2.G.R150.12.005 PS L	270
TK2.G.059.02.05.20 YYR	266	TK2.G.M025.01 EMU R	267	TK2.G.R150.12.005 PS R	269
TK2.G.059.02.05.40 YYL	266	TK2.G.M025.02 EMU L	268	TK2.G.R150.12.005 PT R	269
TK2.G.059.02.05.40 YYR	266	TK2.G.M025.02 EMU R	268	TK2.G.R150.12.005 PU R	269
TK2.G.075.005.038 NS L	260	TK2.G.M035.02 EMU L	268	TK2.G.R200.005 YP R	265
TK2.G.075.005.038 NS R	260	TK2.G.M035.02 EMU R	268	TK2.G.R200.010 YP R	265
TK2.G.075.005.038 NU L	261	TK2.G.M040.01 EMU L	267	TK2.G.R200.020 YP R	265
TK2.G.075.005.038 NU R	261	TK2.G.M040.01 EMU R	267	TK2.G.R200.06.005 PT R	269
TK2.G.100.005.050 NS L	260	TK2.G.M040.02 EMU L	268	TK2.G.R200.12.005 PS R	269
TK2.G.100.005.050 NS R	260	TK2.G.M040.02 EMU R	268	TK2.G.R200.12.005 PT R	269
TK2.G.100.005.050 NU L	261	TK2.G.M045.02 EMU L	268	TOS.K.TK2.G.01A.IC L	258
TK2.G.100.005.050 NU R	261	TK2.G.M045.02 EMU R	268	TOS.K.TK2.G.01A.IC R	258
TK2.G.100.050.030 VS L	263	TK2.G.M050.01 EMU L	267	TOS.K.TK2.G.1AA.IC L	259
TK2.G.100.050.030 VS R	263	TK2.G.M050.01 EMU R	267	TOS.K.TK2.G.1AA.IC R	259
TK2.G.100.050.030 VU L	262	TK2.G.M050.02 EMU L	268		
TK2.G.100.050.030 VU R	262	TK2.G.M050.02 EMU R	268		
TK2.G.1010.A.14.04 L	257	TK2.G.M070.01 EMU L	267		
TK2.G.1010.A.14.04 R	257	TK2.G.M070.01 EMU R	267		
TK2.G.120.060.036 VS L	263	TK2.G.M070.02 EMU L	268		
TK2.G.120.060.036 VS R	263	TK2.G.M070.02 EMU R	268		
TK2.G.120.060.036 VU L	262	TK2.G.M075.02 EMU L	268		
TK2.G.120.060.036 VU R	262	TK2.G.M075.02 EMU R	268		
TK2.G.1212.A.14.04 L	257	TK2.G.M080.01 EMU L	267		
TK2.G.1212.A.14.04 R	257	TK2.G.M080.01 EMU R	267		
TK2.G.150.005.045 NS L	260	TK2.G.M080.02 EMU L	268		
TK2.G.150.005.045 NS R	260	TK2.G.M080.02 EMU R	268		
TK2.G.150.005.045 NU L	261	TK2.G.M100.01 EMU L	267		
TK2.G.150.005.045 NU R	261	TK2.G.M100.01 EMU R	267		
TK2.G.150.020.045 NS L	260	TK2.G.M100.02 EMU L	268		
TK2.G.150.020.045 NS R	260	TK2.G.M100.02 EMU R	268		
TK2.G.150.020.045 NU L	261	TK2.G.M125.01 EMU L	267		
TK2.G.150.020.045 NU R	261	TK2.G.M125.01 EMU R	267		
TK2.G.160.080.048 VS L	263	TK2.G.M125.02 EMU L	268		
TK2.G.160.080.048 VS R	263	TK2.G.M125.02 EMU R	268		
TK2.G.160.080.048 VU L	262	TK2.G.M150.01 EMU L	267		
TK2.G.160.080.048 VU R	262	TK2.G.M150.01 EMU R	267		
TK2.G.1616.A.14.04 L	257	TK2.G.M150.02 EMU L	268		
TK2.G.1616.A.14.04 R	257	TK2.G.M150.02 EMU R	268		
TK2.G.200.005.060 NS L	260	TK2.G.M175.01 EMU L	267		
TK2.G.200.005.060 NS R	260	TK2.G.M175.01 EMU R	267		
TK2.G.200.005.060 NU L	261	TK2.G.M175.02 EMU L	268		
TK2.G.200.005.060 NU R	261	TK2.G.M175.02 EMU R	268		
TK2.G.200.020.060 NS L	260	TK2.G.M200.01 EMU L	267		
TK2.G.200.020.060 NS R	260	TK2.G.M200.01 EMU R	267		
TK2.G.200.020.060 NU L	261	TK2.G.M200.02 EMU L	268		
TK2.G.200.020.060 NU R	261	TK2.G.M200.02 EMU R	268		
TK2.G.200.100.060 VS L	263	TK2.G.M250.02 EMU L	268		
TK2.G.200.100.060 VS R	263	TK2.G.M250.02 EMU R	268		
TK2.G.200.100.060 VU L	262	TK2.G.M300.02 EMU L	268		
TK2.G.200.100.060 VU R	262	TK2.G.M300.02 EMU R	268		
TK2.G.250.010.070 NS L	260	TK2.G.R100.000 YP R	265		
TK2.G.250.010.070 NS R	260	TK2.G.R100.005 YP R	265		
TK2.G.250.010.070 NU L	261	TK2.G.R100.06.005 PS R	269		

simturn AX

simturn DX

simturn PX

simturn H2

simturn K2

simturn C4

simturn GX

simturn E3

simturn E12

simturn FX

simturn Decolletage

simturn OA

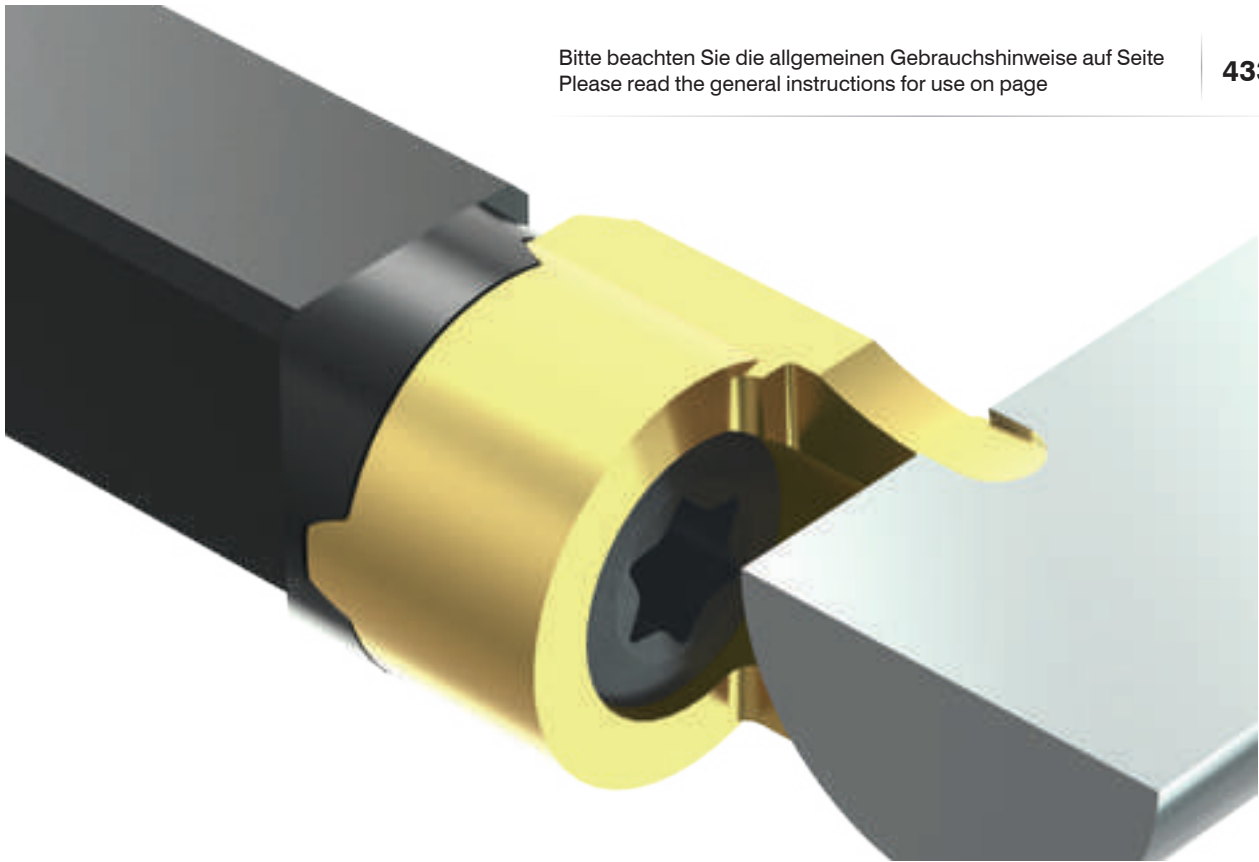
Index

Das Werkzeugsystem im Überblick The Tool System Overview

Kleinteilebearbeitung außen, für Schneidwerkzeugwechsel stirnseitig bedienbar.
Small part machining external, inserts are mountable from the front-side.

Bitte beachten Sie die allgemeinen Gebrauchshinweise auf Seite
Please read the general instructions for use on page

433



Das Werkzeugsystem simturn C4 bietet mit seinem stirnseitig bedienbaren Schneidplatten-Design und Schaftquerschnitten ab 7,0 x 7,0 mm eine Reihe von wichtigen Vorteilen bei der Kleinteilebearbeitung, außen.

Das System ermöglicht den Wechsel des Schneidwerkzeugs, durch eine stirnseitige Bedienung der Spannschraube. Dabei bietet das System Standardwerkzeuge für alle gängigen Anwendungen und Stechtiefen bis 5,5 mm.

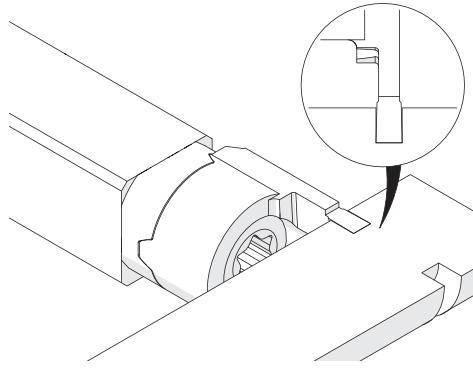
The tool system simturn C4 was designed to meet special requirements in Small Part Machining: It provides an easy-to-use solution by mounting inserts from the front-side, along with shank sizes starting from 7,0 x 7,0 mm on.

All the major applications are available as standard items providing cutting depths up to 5,5 mm.

Standardanwendungen Standard Applications

Ab Seite
As of Page

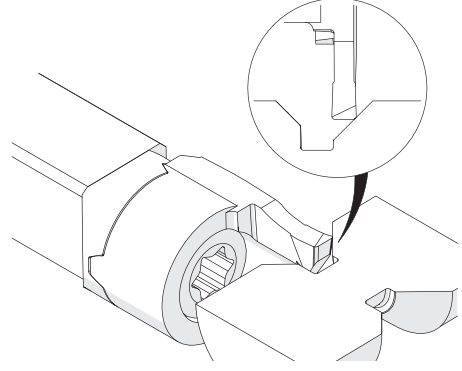
278



Nutenstechen
Grooving

Ab Seite
As of Page

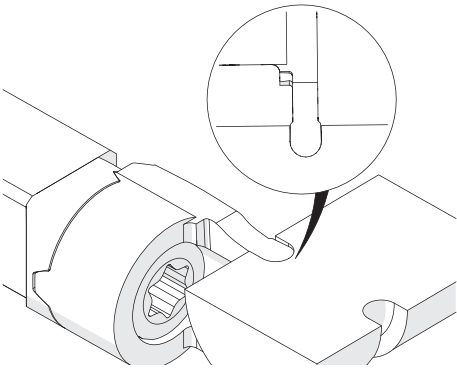
280



Einstechen und Profildrehen
Grooving and Profiling

Seite
Page

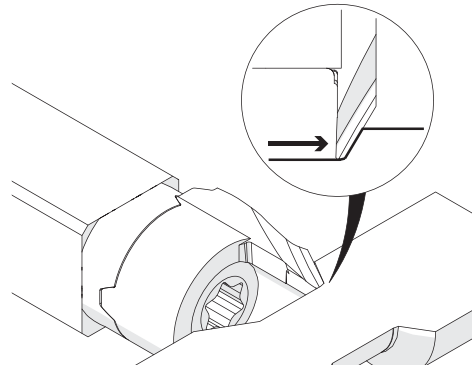
282



Einstechen und Profildrehen, Vollradius
Grooving and Profiling, Full Radius

Seite
Page

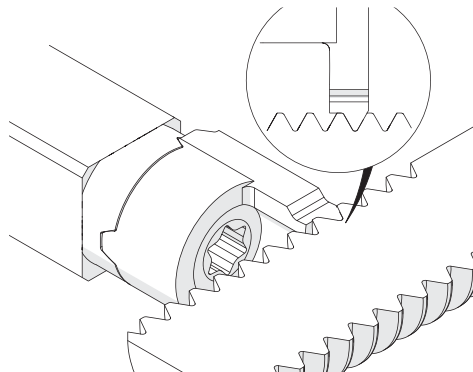
283



Längsdrehen
Turning

Seite
Page

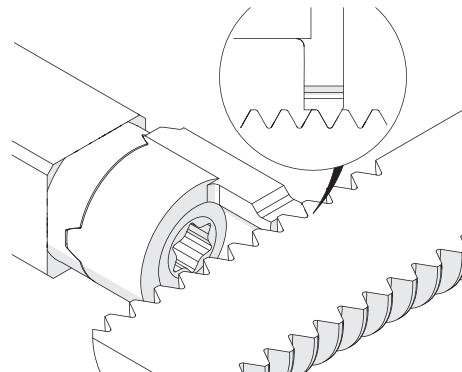
285



Gewinden: Metrisch ISO, Außen, Teilprofil
Threading: Metric ISO, External, Partial Profile

Seite
Page

286

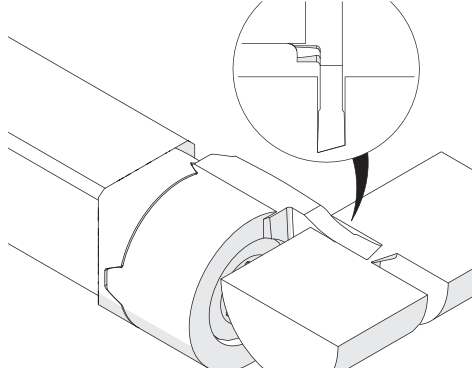


Gewinden: Metrisch ISO, Außen, Vollprofil
Threading: Metric ISO, External, Full Profile

Standardanwendungen Standard Applications

Seite
 Page

287



Abstechen
 Parting off

Klemmhalter, Außen

Klemmhalter für die Kleinteilebearbeitung.

Toolholder, External

Toolholder for small part machining.

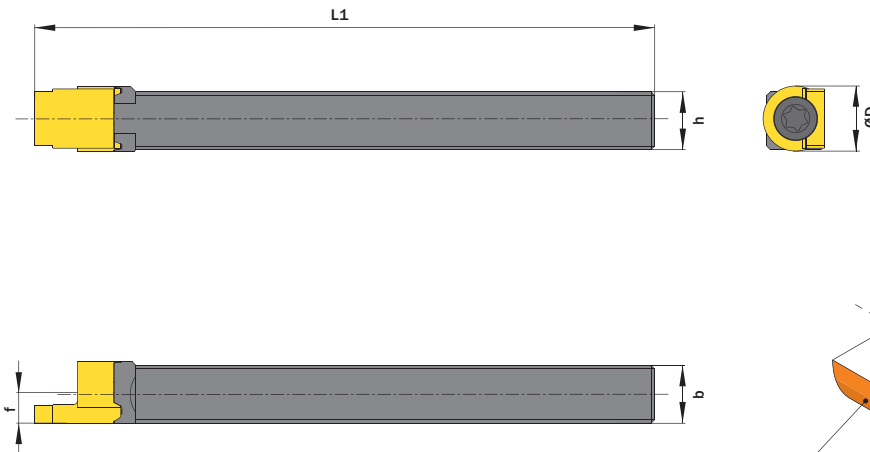
Anzugsmoment (Schraube) // Tightening torque (screw)

4,5 Nm



TW Legende
ST Legend
289

Scan QR-Code Oder besuchen Sie // Or Visit
www.simtek.info/cp/1098



- Hauptsächlich geeignet für diese Flächen
Mainly designed for these surfaces
- Je nach Schneidplatte/Aufnahme ebenfalls möglich
Also possible depending on insert/fixation type

Abbildung zeigt / Drawing shows: TC4.0808.100 R

h	b	L1	Artikelnummer Part number	Webcode www.simtek.com/webcode	ØD	f	Schraube Screw	Schraubenschlüssel Screw driver	Connectcode www.simtek.com/ccode
7,0	7,0	100,0	TC4.0707.100 R/L	R AXXW L AXXX	9,0	4,0	TC M4x12T15F	T15F	R TC4.R L TC4.L
8,0	8,0	100,0	TC4.0808.100 R/L	R AXXU L AXXV	9,0	4,0	TC M4x12T15F	T15F	R TC4.R L TC4.L

Bestellbeispiel // Order example: **TC4.0808.100 R** (R = Rechte Ausführung // Right hand version)

simturn AX
simturn DX
simturn PX
simturn H2
simturn K2
simturn C4
simturn GX
simturn E3
simturn E12
simturn FX
simturn Decoletage
simturn OA
Index

Nutenstechen

Gerade Nutformen, universelle Schneidengeometrie für die Bearbeitung eines breiten Materialspektrums.

Grooving

General grooving, with general cutting edge geometry for a wide variety of workpiece materials.

Schnittwerte (Start) // Cutting parameters (start)

f	Vc
0,02 mm/U	Seite/Page 429

Passende Klemmhalter auf Seite // Suitable toolholders on page 277

SP
HM

R

○

Legende
Legend **289**

Scan QR-Code Oder besuchen Sie // Or Visit www.simtek.info/cp/1081

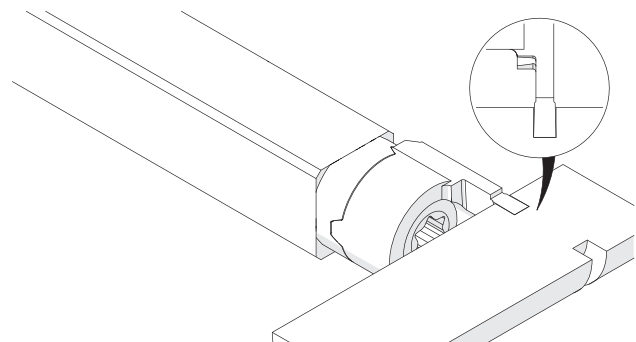
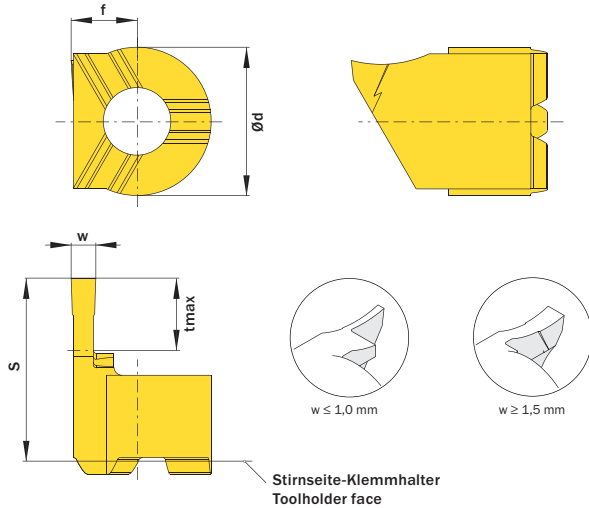


Illustration zeigt beispielhafte Anwendungsmöglichkeit mit ähnlichem Werkzeug.
Image shows exemplary application possibility with similar tool.

Abbildung zeigt / Drawing shows: TC4.150.000.055 GS R

w ±0,015 mm	tmax mm	Artikelnummer Part number	Webcode www.simtek.com/webcode	Unsere erste Wahl Our first choice	Ød mm	f mm	S mm	Connectcode www.simtek.com/code
▼ w = 0,5 mm								
0,5	2,5	TC4.050.000.025 GS R/L	R AXN9 L AXPA	X808 X408	9,0	4,0	11,0	R TC4.R L TC4.L
▼ w = 0,75 mm								
0,75	3,75	TC4.075.000.038 GS R/L	R AXN5 L AXN6	X808 X408	9,0	4,0	11,0	R TC4.R L TC4.L
▼ w = 1,0 mm								
1,0	5,5	TC4.100.000.055 GS R/L	R AXNX L AXNY	X808 X408	9,0	4,0	11,0	R TC4.R L TC4.L
▼ w = 1,5 mm								
1,5	5,5	TC4.150.000.055 GS R/L	R AXNQ L AXNS	X808 X408	9,0	4,0	11,0	R TC4.R L TC4.L

Bestellbeispiel // Order example: **TC4.100.000.055 GS R X808** (R = Rechte Ausführung // Right hand version, X808 = Schneidstoff // Grade)

Nutenstechen

Gerade Nutformen, spezielle Schneidengeometrie für die Bearbeitung von Messing, Kupferlegierungen und anderen kurzspanenden Werkstoffen.

Grooving

General grooving, with special cutting edge geometry for brass, copper-based alloys and short-chipping materials.

Schnittwerte (Start) // Cutting parameters (start)	
f	Vc
0,02 mm/U	Seite/Page 429

Passende Klemmhalter auf Seite // Suitable toolholders on page 277



 Legende Legend 289
 Scan QR-Code Oder besuchen Sie // Or Visit www.simtek.info/cp/1078

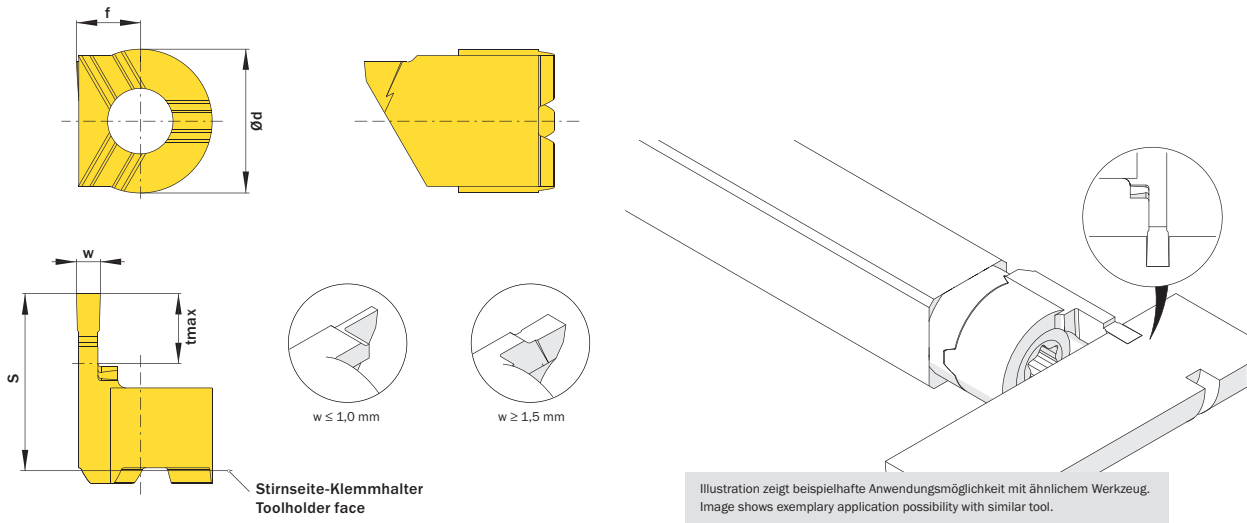


Abbildung zeigt / Drawing shows: TC4.150.000.055 GU R

w	tmax	Artikelnummer Part number	Webcode www.simtek.com/webcode	Unsere erste Wahl Our first choice	Ød	f	S	Connectcode www.simtek.com/code	
mm	mm			P K M N S	mm	mm	mm		
▼ w = 0,5 mm									
0,5	2,5	TC4.050.000.025 GU R/L	R AXP5 L AXP6	X808 X408	9,0	4,0	11,0	R TC4.R L TC4.L	
▼ w = 0,75 mm									
0,75	3,75	TC4.075.000.038 GU R/L	R AXP1 L AXP2	X808 X408	9,0	4,0	11,0	R TC4.R L TC4.L	
▼ w = 1,0 mm									
1,0	5,5	TC4.100.000.055 GU R/L	R AXPT L AXPU	X808 X408	9,0	4,0	11,0	R TC4.R L TC4.L	
▼ w = 1,5 mm									
1,5	5,5	TC4.150.000.055 GU R/L	R AXPK L AXPM	X808 X408	9,0	4,0	11,0	R TC4.R L TC4.L	

Bestellbeispiel // Order example: **TC4.150.000.055 GU R X808** (R = Rechte Ausführung // Right hand version, X808 = Schneidstoff // Grade)

simturn AX
simturn DX
simturn PX
simturn H2
simturn K2
simturn C4
simturn GX
simturn E3
simturn E12
simturn FX
simturn Decolletage
simturn OA
Index

Einstecken und Profildrehen

CNC-Konturdrehen, universelle Schneidengeometrie für die Bearbeitung eines breiten Materialspektrums.

Grooving and Profiling

CNC profiling, with general cutting edge geometry for a wide variety of workpiece materials.

Schnittwerte (Start) // Cutting parameters (start)

f	Vc
0,02 mm/U	Seite/Page 429

Passende Klemmhalter auf Seite // Suitable toolholders on page 277

SP
HM

R

○

Legende
Legend **289**

Scan
QR-Code

Oder besuchen Sie // Or Visit
www.simtek.info/cp/1080

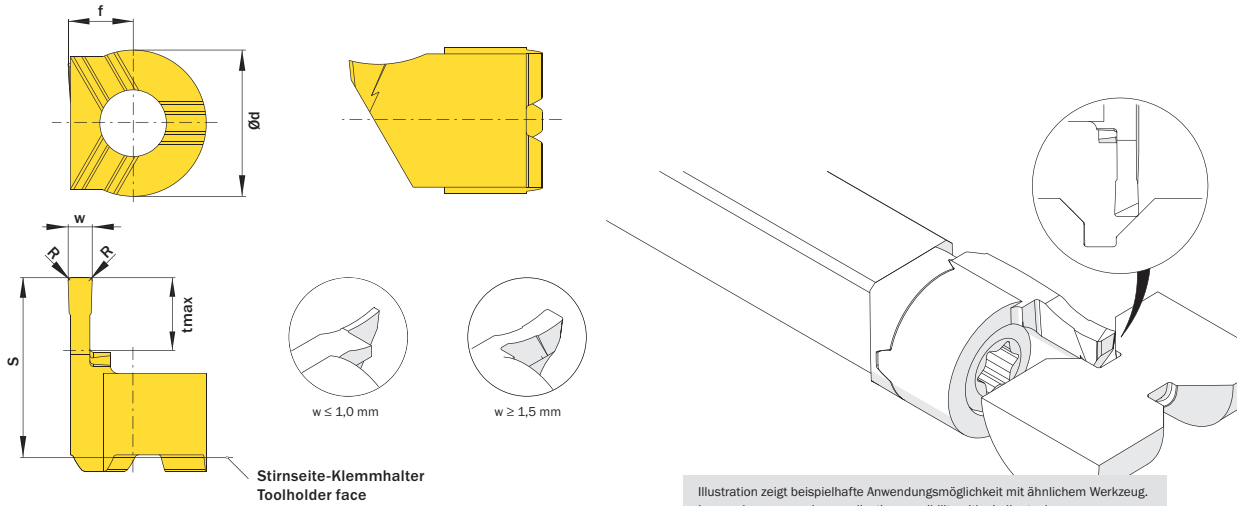


Illustration zeigt beispielhafte Anwendungsmöglichkeit mit ähnlichem Werkzeug.
Image shows exemplary application possibility with similar tool.

Abbildung zeigt / Drawing shows: TC4.150.020.055 NS R

w	R	tmax	Artikelnummer Part number	Webcode www.simtek.com/webcode	Unsere erste Wahl Our first choice	Ød	f	S	Connectcode www.simtek.com/ccode
mm	mm	mm			P K M N S	mm	mm	mm	
▼ w = 0,5 mm									
0,5	0,05	2,5	TC4.050.005.025 NS R/L	R AXSF L AXSG	X808 X408	9,0	4,0	11,0	R TC4.R L TC4.L
▼ w = 0,75 mm									
0,75	0,05	3,75	TC4.075.005.038 NS R/L	R AXSB L AXSC	X808 X408	9,0	4,0	11,0	R TC4.R L TC4.L
▼ w = 1,0 mm									
1,0	0,05	5,5	TC4.100.005.055 NS R/L	R AXQ3 L AXQ4	X808 X408	9,0	4,0	11,0	R TC4.R L TC4.L
▼ w = 1,5 mm									
1,5	0,2	5,5	TC4.150.020.055 NS R/L	R AXQX L AXQY	X808 X408	9,0	4,0	11,0	R TC4.R L TC4.L

Bestellbeispiel // Order example: **TC4.100.005.055 NS R X808** (R = Rechte Ausführung // Right hand version, X808 = Schneidstoff // Grade)

Einstecken und Profildrehen

CNC-Konturdrehen, spezielle Schneidengeometrie für die Bearbeitung von Messing, Kupferlegierungen und anderen kurzspanenden Werkstoffen.


Grooving and Profiling

CNC profiling, with special cutting edge geometry for brass, copper-based alloys and short-chipping materials.

Schnittwerte (Start) // Cutting parameters (start)

f	Vc
0,02 mm/U	Seite/Page 429

Passende Klemmhalter auf Seite // Suitable toolholders on page 277



 Legende Legend 289
 Scan QR-Code Oder besuchen Sie // Or Visit www.simtek.info/cp/1079

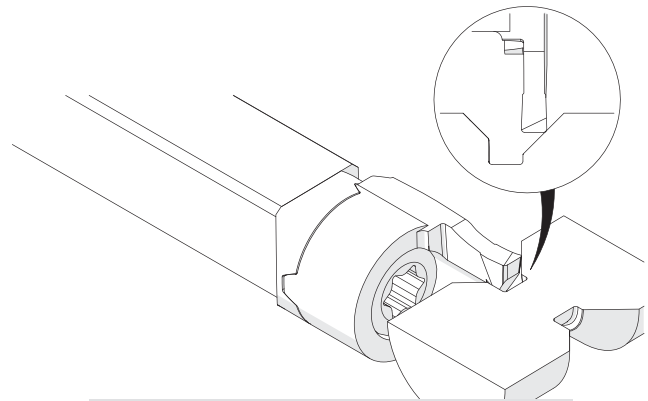
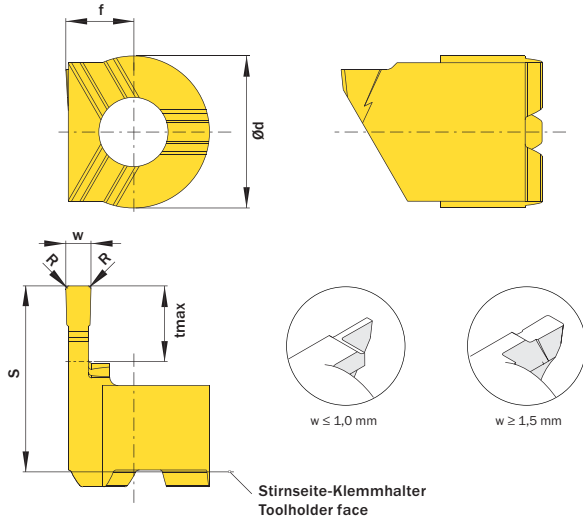


Illustration zeigt beispielhafte Anwendungsmöglichkeit mit ähnlichem Werkzeug. Image shows exemplary application possibility with similar tool.

Abbildung zeigt / Drawing shows: TC4.150.020.055 NU R

w	R	tmax	Artikelnummer Part number	Webcode www.simtek.com/webcode	Unsere erste Wahl Our first choice	Ød	f	S	Connectcode www.simtek.com/ccode
mm	mm	mm			P K M N S	mm	mm	mm	
▼ w = 0,5 mm									
0,5	0,05	2,5	TC4.050.005.025 NU R/L	R AXTB L AXTC	X808 X408	9,0	4,0	11,0	R TC4.R L TC4.L
▼ w = 0,75 mm									
0,75	0,05	3,75	TC4.075.005.038 NU R/L	R AXS7 L AXS8	X808 X408	9,0	4,0	11,0	R TC4.R L TC4.L
▼ w = 1,0 mm									
1,0	0,05	5,5	TC4.100.005.055 NU R/L	R AXS2 L AXS0	X808 X408	9,0	4,0	11,0	R TC4.R L TC4.L
▼ w = 1,5 mm									
1,5	0,2	5,5	TC4.150.020.055 NU R/L	R AXST L AXSU	X808 X408	9,0	4,0	11,0	R TC4.R L TC4.L

Bestellbeispiel // Order example: **TC4.150.020.055 NU R X808** (R = Rechte Ausführung // Right hand version, X808 = Schneidstoff // Grade)

simturn AX
simturn DX
simturn PX
simturn H2
simturn H2
simturn K2
simturn C4
simturn GX
simturn E3
simturn E12
simturn FX
simturn Decolletage
simturn OA
Index

Einstecken und Profildrehen, Vollradius

Vollradiusnuten, CNC-Konturdrehen. Ausführung „U“ für Messing, Kupferlegierungen und andere kurzspanende Werkstoffe. Ausführung „S“ für den universellen Einsatz.

Grooving and Profiling, Full Radius

Full radius, CNC profiling. Version „U“ for brass, copper-base alloys and short-chipping materials. Version „S“ for a very wide variety of workpiece materials.

Schnittwerte (Start) // Cutting parameters (start)

f	Vc
0,02 mm/U	Seite/Page 429

Passende Klemmhalter auf Seite // Suitable toolholders on page 277







 Legende Legend **289**

 Scan QR-Code
 Oder besuchen Sie // Or Visit www.simtek.info/cp/1076

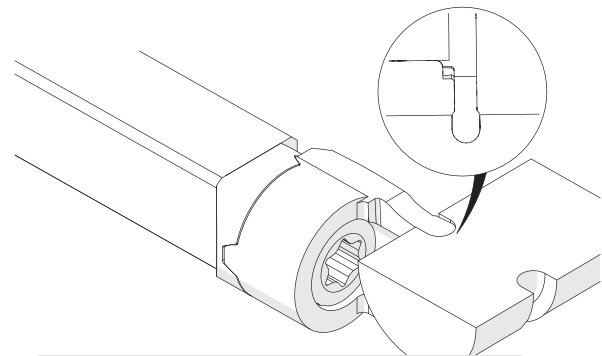
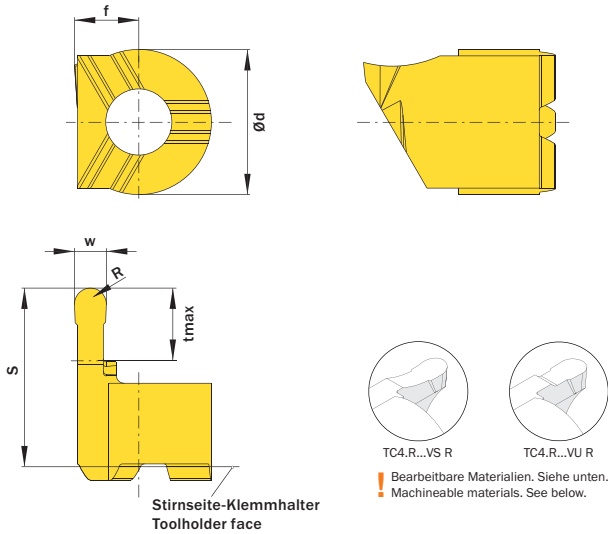


Illustration zeigt beispielhafte Anwendungsmöglichkeit mit ähnlichem Werkzeug. Image shows exemplary application possibility with similar tool.

Abbildung zeigt / Drawing shows: TC4.100.050.030 VS R

w ^{+0,03}	R	tmax	Artikelnummer Part number	Webcode www.simtek.com/webcode	Unsere erste Wahl Our first choice	Ød	f	S	Connectcode www.simtek.com/code
mm	mm	mm			P K M N S	mm	mm	mm	
1,0	0,5	3,0	TC4.100.050.030 VS R/L	R AXQN L AXQP	X808 X408	9,0	4,0	11,0	R TC4.R L TC4.L
1,0	0,5	3,0	TC4.100.050.030 VU R/L	R AYQV L AYQU	X808 X408	9,0	4,0	11,0	R TC4.R L TC4.L

Bestellbeispiel // Order example: **TC4.100.050.030 VU R X808** (R = Rechte Ausführung // Right hand version, X808 = Schneidstoff // Grade)

TC4...VS R: Für die Bearbeitung eines breiten Materialspektrums // For a wide variety of workpiece materials.

TC4...VU R: Für die Bearbeitung von Messing, Kupferlegierungen und anderen kurzspanenden Werkstoffen. For brass, copper-based alloys and short-chipping materials

Längsdrehen

Für das Längsdrehen bzw. Rückwärtsdrehen „hinter Bund“.

Turning

For turning as well as for back turning „behind shoulder“.

Schnittwerte (Start) // Cutting parameters (start)	
f	Vc
0,05 mm/U	Seite/Page 429

Passende Klemmhalter auf Seite // Suitable toolholders on page 277

SP

HM

R

Legende
Legend **289**

Scan
QR-Code

Oder besuchen Sie // Or Visit
www.simtek.info/cp/1085

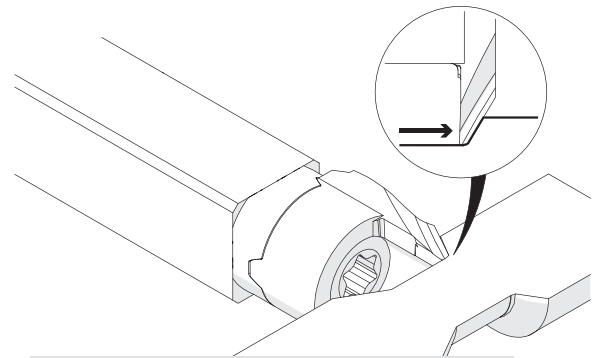
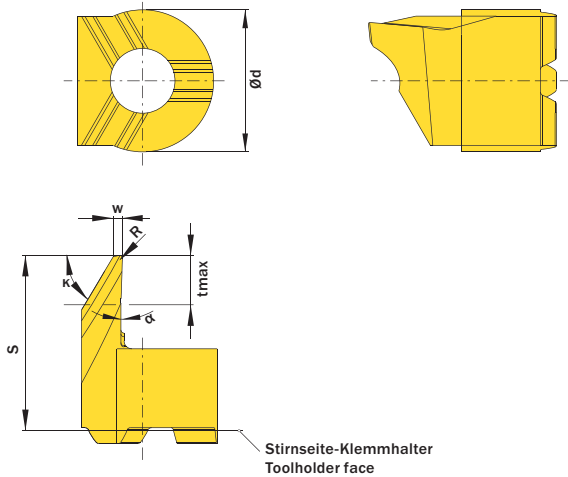


Illustration zeigt beispielhafte Anwendungsmöglichkeit mit ähnlichem Werkzeug.
Image shows exemplary application possibility with similar tool.

Abbildung zeigt / Drawing shows: TC4.059.02.06.020 YY R

K	α	w mm	R mm	Artikelnummer Part number	Webcode www.simtek.com/webcode		Unsere erste Wahl Our first choice		Ød mm	S mm	tmax mm	Connectcode www.simtek.com/ccode	
					R	L	P	K				M	N
59°	2°	0,59	0,1	TC4.059.02.06.010 YY R/L	R A02M	L A02K	X808	X408	9,0	11,0	3,0	R TC4.R	L TC4.L
59°	2°	0,59	0,2	TC4.059.02.06.020 YY R/L	R AXND	L AXNE	X800	X400	9,0	11,0	3,0	R TC4.R	L TC4.L
59°	2°	0,59	0,4	TC4.059.02.06.040 YY R/L	R AXNB	L AXNC	X800	X400	9,0	11,0	3,0	R TC4.R	L TC4.L

Bestellbeispiel // Order example: **TC4.059.02.06.020 YY R X800** (R = Rechte Ausführung // Right hand version, X800 = Schneidstoff // Grade)

simturn AX
simturn DX
simturn PX
simturn H2
simturn K2
simturn C4
simturn GX
simturn E3
simturn E12
simturn FX
simturn Decolletage
simturn OA
Index

Längsdrehen, mit Spantreppe Typ „E“

Typ „E“ Spantreppe, für optimale Leistung und Spanbildung.

Turning, Cutting Edge Design „E“

Cutting edge design „E“, for high performance and chip control.

Schnittwerte (Start) // Cutting parameters (start)

f	Vc
0,02 mm/U	Seite/Page 429

Passende Klemhalter auf Seite // Suitable toolholders on page 277

SP
HM

R

○

Legende
Legend **289**

Scan
QR-Code

Oder besuchen Sie // Or Visit
www.simtek.info/cp/1243

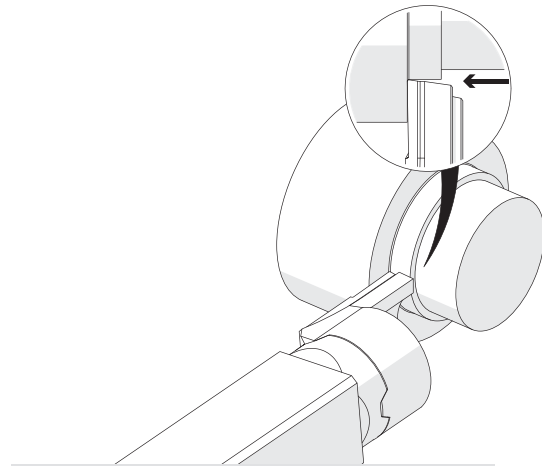
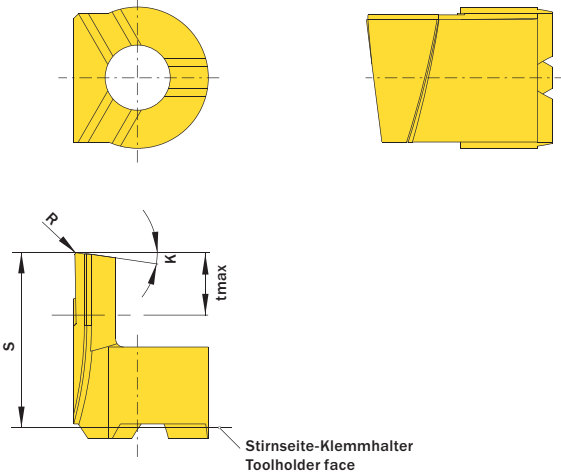


Abbildung zeigt / Drawing shows: TC4.008.10.010 YE R

K	R mm	Artikelnummer Part number	Webcode www.simtek.com/webcode		Unsere erste Wahl Our first choice		S mm	tmax mm	Connectcode www.simtek.com/code			
			P	K	M	N			S	R	L	T
8°	0,1	TC4.008.10.010 YE R/L	R A01M	L A01N	X808	X408	11,0	4,0	R	TC4-R	L	TC4-L
30°	0,1	TC4.030.10.010 YE R/L	R A01Q	L A01P	X808	X408	11,0	4,0	R	TC4-R	L	TC4-L
50°	0,1	TC4.050.10.010 YE R/L	R A01T	L A01S	X808	X408	11,0	4,0	R	TC4-R	L	TC4-L

Bestellbeispiel // Order example: **TC4.050.10.010 YE R X808** (R = Rechte Ausführung // Right hand version, X808 = Schneidstoff // Grade)

Gewindedrehen, Metr. ISO, Außen, Teilprofil

Mehrbereichswerkzeuge für verschiedene Steigungen.

Threading, Metr. ISO, External, Partial Profile

Multi-purpose tools, usable for different pitches.

Schnittwerte (Start) // Cutting parameters (start)

f	Vc
0,02 mm/U	Seite/Page 429

Passende Klemmhalter auf Seite // Suitable toolholders on page 277

Empf. Zustellungsart // Recom. infeed method
Flankenzustellung // Flank infeed (Seite/Page 433)

Bitte Hinweise im Anhang beachten // Please read add. notes
T01 (Seite/Page 288)

SP

HM

R

○

Legende
Legend **289**

Scan QR-Code Oder besuchen Sie // Or Visit
www.simtek.info/cp/1084

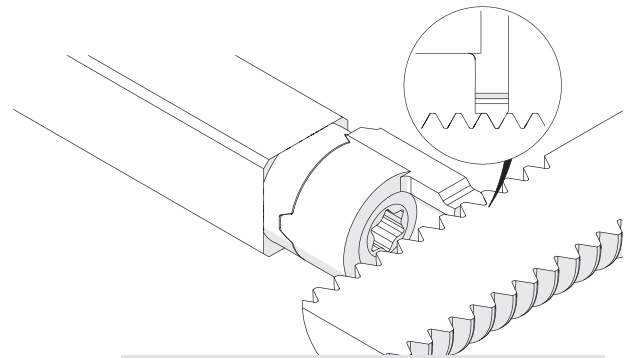
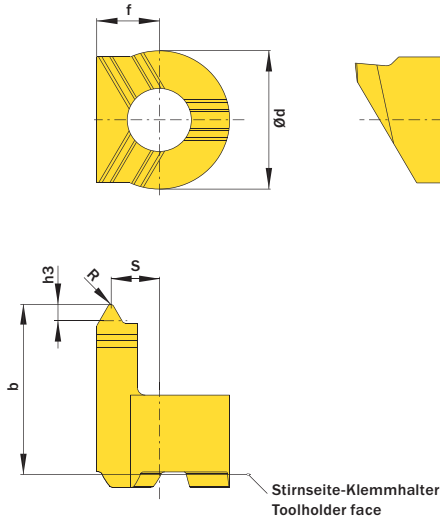


Illustration zeigt beispielhafte Anwendungsmöglichkeit mit ähnlichem Werkzeug.
Image shows exemplary application possibility with similar tool.

Abbildung zeigt / Drawing shows: TC4.M150.01 EMU R

Steigung (von) Pitch (as of)	Steigung (bis) Pitch (up to)	Artikelnummer Part number	Webcode www.simtek.com/webcode	Unsere erste Wahl Our first choice					b	Ød	f	h3	R	S	Connectcode www.simtek.com/ccode		
				P	K	M	N	S							R	L	TC4.L
0,25	0,45	TC4.M025.01 EMU R/L	R AYQQ L AYQP	X808	X408			11,0	9,0	4,0	0,15	0,04	3,6	R	TC4.R	L	TC4.L
0,4	0,6	TC4.M040.01 EMU R/L	R AXMF L AXMG	X808	X408			11,0	9,0	4,0	0,25	0,06	3,5	R	TC4.R	L	TC4.L
0,5	0,75	TC4.M050.01 EMU R/L	R AXMB L AXMC	X808	X408			11,0	9,0	4,0	0,31	0,07	3,4	R	TC4.R	L	TC4.L
0,7	1,0	TC4.M070.01 EMU R/L	R AXK7 L AXK8	X808	X408			11,0	9,0	4,0	0,43	0,1	3,3	R	TC4.R	L	TC4.L
0,8	1,25	TC4.M080.01 EMU R/L	R AXK5 L AXK6	X808	X408			11,0	9,0	4,0	0,49	0,12	3,3	R	TC4.R	L	TC4.L
1,0	1,5	TC4.M100.01 EMU R/L	R AXK3 L AXK4	X808	X408			11,0	9,0	4,0	0,61	0,14	3,2	R	TC4.R	L	TC4.L
1,25	1,75	TC4.M125.01 EMU R/L	R AXK1 L AXK2	X808	X408			11,0	9,0	4,0	0,77	0,18	3,1	R	TC4.R	L	TC4.L
1,5	2,0	TC4.M150.01 EMU R/L	R AXKZ L AXK0	X808	X408			11,0	9,0	4,0	0,92	0,22	3,0	R	TC4.R	L	TC4.L
1,75	2,5	TC4.M175.01 EMU R/L	R AYUV L AYUW	X808	X408			11,0	9,0	4,0	1,07	0,25	2,9	R	TC4.R	L	TC4.L
2,0	2,5	TC4.M200.01 EMU R/L	R AXKX L AXKY	X808	X408			11,0	9,0	4,0	1,23	0,29	2,8	R	TC4.R	L	TC4.L

Bestellbeispiel // Order example: **TC4.M070.01 EMU R X808** (R = Rechte Ausführung // Right hand version, X808 = Schneidstoff // Grade)

Bitte beachten Sie die zusätzlichen Hinweise im Infobereich rechts oben.

Please read the additional notes mentioned in the information area on the top right corner of this page.

simturn AX
simturn DX
simturn PX
simturn H2
simturn K2
simturn C4
simturn GX
simturn E3
simturn E12
simturn FX
simturn Decolletage
simturn OA
Index

Gewindedrehen, Metr. ISO, Außen, Vollprofil

Herstellung des vollständigen Gewindeprofils mit notwendiger Tiefe sowie Kopf- und Fußradien.

Threading, Metr. ISO, External, Full Profile

For a complete thread profile with correct depth, top radius and bottom radius.

Schnittwerte (Start) // Cutting parameters (start)

f	Vc
0,02 mm/U	Seite/Page 429

Empf. Zustellungsart // Recom. infeed method
Flankenzustellung // Flank infeed (Seite/Page 433)

Passende Klemmhalter auf Seite // Suitable toolholders on page 277

SP
HM

R

Scan QR-Code

Legende
Legend

289

Oder besuchen Sie // Or Visit
www.simtek.info/cp/1077

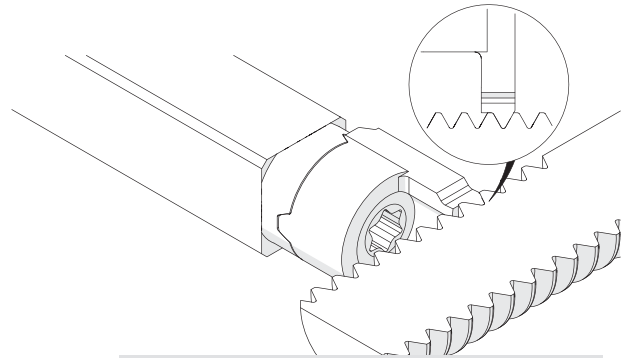
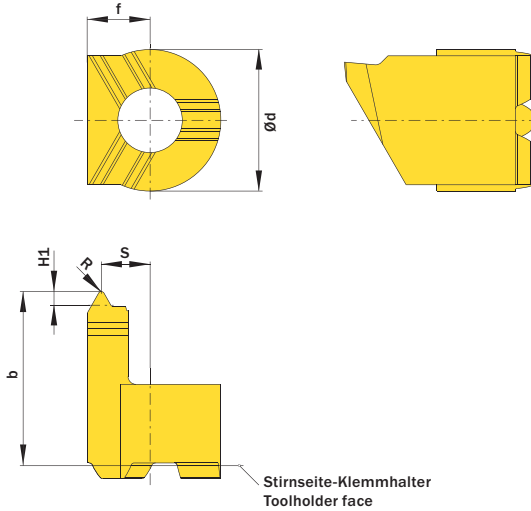


Illustration zeigt beispielhafte Anwendungsmöglichkeit mit ähnlichem Werkzeug.
Image shows exemplary application possibility with similar tool.

Abbildung zeigt / Drawing shows: TC4.M150.02 EMU R

Steigung (von) Pitch (as of)	Artikelnummer Part number	Webcode www.simtek.com/webcode	Unsere erste Wahl Our first choice				b	Ød	f	H1	R	S	Connectcode www.simtek.com/code		
			P	K	M	S									
0,25	TC4.M025.02 EMU R/L	R AYQN L AYQM	X808	X408	11,0	9,0	4,0	0,15	0,04	3,7	R	TC4.R	L	TC4.L	
0,35	TC4.M035.02 EMU R/L	R AXKV L AXKW	X808	X408	11,0	9,0	4,0	0,22	0,05	3,6	R	TC4.R	L	TC4.L	
0,4	TC4.M040.02 EMU R/L	R AXKT L AXKU	X808	X408	11,0	9,0	4,0	0,25	0,06	3,6	R	TC4.R	L	TC4.L	
0,45	TC4.M045.02 EMU R/L	R AXKQ L AXKS	X808	X408	11,0	9,0	4,0	0,28	0,07	3,6	R	TC4.R	L	TC4.L	
0,5	TC4.M050.02 EMU R/L	R AXKN L AXKP	X808	X408	11,0	9,0	4,0	0,31	0,07	3,5	R	TC4.R	L	TC4.L	
0,7	TC4.M070.02 EMU R/L	R AXKH L AXKJ	X808	X408	11,0	9,0	4,0	0,43	0,1	3,4	R	TC4.R	L	TC4.L	
0,75	TC4.M075.02 EMU R/L	R AYQS L AYQT	X808	X408	11,0	9,0	4,0	0,46	0,11	3,4	R	TC4.R	L	TC4.L	
0,8	TC4.M080.02 EMU R/L	R AXKF L AXKG	X808	X408	11,0	9,0	4,0	0,49	0,11	3,4	R	TC4.R	L	TC4.L	
1,0	TC4.M100.02 EMU R/L	R AXKD L AXKE	X808	X408	11,0	9,0	4,0	0,61	0,12	3,3	R	TC4.R	L	TC4.L	
1,25	TC4.M125.02 EMU R/L	R AXKB L AXKC	X808	X408	11,0	9,0	4,0	0,77	0,15	3,2	R	TC4.R	L	TC4.L	
1,5	TC4.M150.02 EMU R/L	R AXJ9 L AXKA	X808	X408	11,0	9,0	4,0	0,92	0,2	3,1	R	TC4.R	L	TC4.L	
1,75	TC4.M175.02 EMU R/L	R AXJ7 L AXJ8	X808	X408	11,0	9,0	4,0	1,07	0,25	3,0	R	TC4.R	L	TC4.L	
2,0	TC4.M200.02 EMU R/L	R AXJ5 L AXJ6	X808	X408	11,0	9,0	4,0	1,23	0,25	2,9	R	TC4.R	L	TC4.L	

Bestellbeispiel // Order example: **TC4.M050.02 EMU R X808** (R = Rechte Ausführung // Right hand version, X808 = Schneidstoff // Grade)

Abstechen

Verfügbar mit/ohne geschliffener Spanformrinne.

Parting Off

Available with/without ground chip form channel.

Schnittwerte (Start) // Cutting parameters (start)

f	Vc
0,02 mm/U	Seite/Page 429

Passende Klemmhalter auf Seite // Suitable toolholders on page 277

SP

HM

R

Legende
Legend

289

Scan
QR-Code

Oder besuchen Sie // Or Visit
www.simtek.info/cp/1083

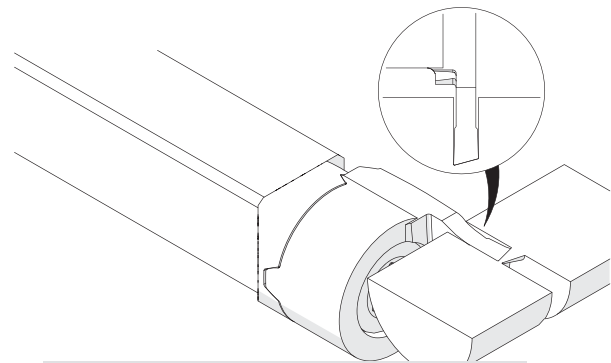
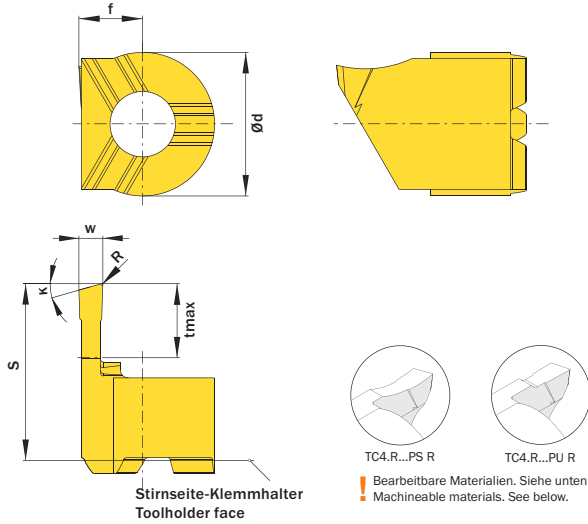


Illustration zeigt beispielhafte Anwendungsmöglichkeit mit ähnlichem Werkzeug.
Image shows exemplary application possibility with similar tool.

Abbildung zeigt / Drawing shows: TC4.R150.15.005 PS R

w	k	R	Artikelnummer Part number	Webcode www.simtek.com/webcode	Unsere erste Wahl Our first choice	Ød	f	S	tmax	Connectcode www.simtek.com/ccode
mm		mm			P K M N S	mm	mm	mm	mm	
1,0	15	0,05	TC4.R100.15.005 PS R	AXNA	X800 X400	9,0	4,0	11,0	5,5	TC4.R
1,0	15	0,05	TC4.R100.15.005 PU R	AYK7	X800 X400	9,0	4,0	11,0	5,5	TC4.R

Bestellbeispiel // Order example: **TC4.R100.15.005 PS R X800** (R = Rechte Ausführung // Right hand version, X800 = Schneidstoff // Grade)

TC4.R...PS R: Für die Bearbeitung eines breiten Materialspektrums // For a wide variety of workpiece materials.

TC4.R...PU R: Für die Bearbeitung von Messing, Kupferlegierungen und anderen kurzspanenden Werkstoffen. // For brass, copper-based alloys and short-chipping materials

Info

Hinweisliste
Additional information

T01

Bei den simturn Teilprofil-Gewindeschneidplatten für metrische ISO-Gewinde handelt es sich um Mehrbereichswerkzeuge, d.h. dass mit einem Werkzeug unterschiedliche Steigungen gefertigt werden können.

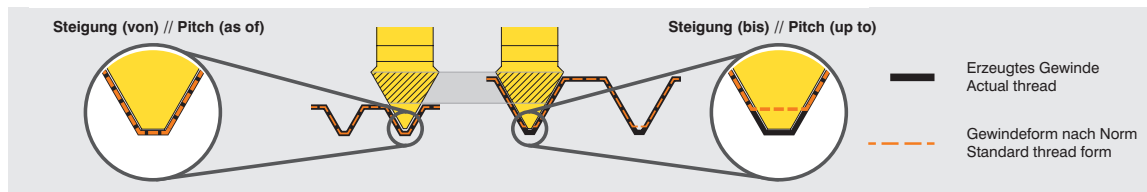
Das Schneidwerkzeug ist dabei immer auf die angegebene „Steigung (von)“ ausgelegt, wodurch ein normgerechtes Gewinde beim Fertigen dieser Steigung entsteht.

Die ebenfalls angegebene „Steigung (bis)“ kann mit diesem Werkzeug ebenfalls gefertigt werden. Es entsteht hierbei jedoch ein - gegenüber der Norm - geringfügig tieferes Gewinde. Die geringfügig höhere Gewindetiefe ist i.d.R. akzeptabel, es muss jedoch immer der Einzelfall beurteilt werden.

The simturn threading inserts with partial profile for metric ISO-threads are multi-purpose tools. This means that each insert is offering the possibility to machine different pitches.

The insert is always designed to meet the pitch given as „Pitch (as of)“: Machining this pitch will result in a standard conform thread form.

The given „Pitch (up to)“ can be machined too with this insert at the expense of standard conformity: The resulting thread will be slightly deeper than the standard. The deeper thread is usually acceptable, but the application and use needs to be evaluated.



Beispiel // Example

Info

Legende Legend

- SP** Schneidwerkzeug aus Hartmetall // Carbide insert // Outils coupants en carbure de tungstène
HM Inserto in metallo duro // Inserto de carburo // Karbür kesici uç
- TW** Trägerwerkzeug aus Stahl // Steel toolholder // Porte-outils en acier // Porta inserto in acciaio
ST Porta-herramientas de acero // Çelik tutucu
- R** Rechts wie gezeichnet // Right hand version shown, left hand version inversely // A droite comme présenté // In figura utensile destro
Modelo derecho // Sağ model
- CU** Speziell für Messing, Kupferlegierungen und kurzspanende Materialien For brass, copper-base alloys and other short-chipping materials // Spécialement pour alliages laiton et cuivre // Per ottone, leghe a base di rame e tutti gli altri materiali a truciolo corto
Especializado para latón, aleación de cobre y materiales con virutas cortas // Pirinç , Bakır ve kısa talaşlı malzemeler için
- Nur für die Außenbearbeitung geeignet // Only suitable for external applications // Seulement pour opérations extérieures
Solo per lavorazione esterna // Soló para mecanizado externo // Dış çaplar için

simturn AX

simturn DX

simturn PX

simturn H2

simturn K2

simturn C4

simturn GX

simturn E3

simturn E12

simturn FX

simturn
Decolletage

simturn OA

Index

289

Index

simturn C4 Produktverzeichnis
simturn C4 Product List

Artikelnr. // Part Nr.	S/P	Artikelnr. // Part Nr.	S/P
TC4.008.10.010 YE L	284	TC4.M050.02 EMU L	286
TC4.008.10.010 YE R	284	TC4.M050.02 EMU R	286
TC4.030.10.010 YE L	284	TC4.M070.01 EMU L	285
TC4.030.10.010 YE R	284	TC4.M070.01 EMU R	285
TC4.050.000.025 GS L	278	TC4.M070.02 EMU L	286
TC4.050.000.025 GS R	278	TC4.M070.02 EMU R	286
TC4.050.000.025 GU L	279	TC4.M075.02 EMU L	286
TC4.050.000.025 GU R	279	TC4.M075.02 EMU R	286
TC4.050.005.025 NS L	280	TC4.M080.01 EMU L	285
TC4.050.005.025 NS R	280	TC4.M080.01 EMU R	285
TC4.050.005.025 NU L	281	TC4.M080.02 EMU L	286
TC4.050.005.025 NU R	281	TC4.M080.02 EMU R	286
TC4.050.10.010 YE L	284	TC4.M100.01 EMU L	285
TC4.050.10.010 YE R	284	TC4.M100.01 EMU R	285
TC4.059.02.06.010 YY L	283	TC4.M100.02 EMU L	286
TC4.059.02.06.010 YY R	283	TC4.M100.02 EMU R	286
TC4.059.02.06.020 YY L	283	TC4.M125.01 EMU L	285
TC4.059.02.06.020 YY R	283	TC4.M125.01 EMU R	285
TC4.059.02.06.040 YY L	283	TC4.M125.02 EMU L	286
TC4.059.02.06.040 YY R	283	TC4.M125.02 EMU R	286
TC4.0707.100 L	277	TC4.M150.01 EMU L	285
TC4.0707.100 R	277	TC4.M150.01 EMU R	285
TC4.075.000.038 GS L	278	TC4.M150.02 EMU L	286
TC4.075.000.038 GS R	278	TC4.M150.02 EMU R	286
TC4.075.000.038 GU L	279	TC4.M175.01 EMU L	285
TC4.075.000.038 GU R	279	TC4.M175.01 EMU R	285
TC4.075.005.038 NS L	280	TC4.M175.02 EMU L	286
TC4.075.005.038 NS R	280	TC4.M175.02 EMU R	286
TC4.075.005.038 NU L	281	TC4.M200.01 EMU L	285
TC4.075.005.038 NU R	281	TC4.M200.01 EMU R	285
TC4.0808.100 L	277	TC4.M200.02 EMU L	286
TC4.0808.100 R	277	TC4.M200.02 EMU R	286
TC4.100.000.055 GS L	278	TC4.R100.15.005 PS R	287
TC4.100.000.055 GS R	278	TC4.R100.15.005 PU R	287
TC4.100.000.055 GU L	279		
TC4.100.000.055 GU R	279		
TC4.100.005.055 NS L	280		
TC4.100.005.055 NS R	280		
TC4.100.005.055 NU L	281		
TC4.100.005.055 NU R	281		
TC4.100.050.030 VS L	282		
TC4.100.050.030 VS R	282		
TC4.100.050.030 VU L	282		
TC4.100.050.030 VU R	282		
TC4.150.000.055 GS L	278		
TC4.150.000.055 GS R	278		
TC4.150.000.055 GU L	279		
TC4.150.000.055 GU R	279		
TC4.150.020.055 NS L	280		
TC4.150.020.055 NS R	280		
TC4.150.020.055 NU L	281		
TC4.150.020.055 NU R	281		
TC4.M025.01 EMU L	285		
TC4.M025.01 EMU R	285		
TC4.M025.02 EMU L	286		
TC4.M025.02 EMU R	286		
TC4.M035.02 EMU L	286		
TC4.M035.02 EMU R	286		
TC4.M040.01 EMU L	285		
TC4.M040.01 EMU R	285		
TC4.M040.02 EMU L	286		
TC4.M040.02 EMU R	286		
TC4.M045.02 EMU L	286		
TC4.M045.02 EMU R	286		
TC4.M050.01 EMU L	285		
TC4.M050.01 EMU R	285		

Das Werkzeugsystem im Überblick The Tool System Overview

Wenn es um **höhere Stechtiefen** geht. In case you need **higher cutting** depths.

Alle Anwendungen auf einen Blick / All applications at one glance

Einstechen · Profildrehen · Gewinden · Abstechen · Poly-V-Riemennuten
Grooving · Profiling · Threading · Parting-Off · Poly-V-Belt Grooves

Detaillierte Übersicht aller Anwendungen ab Seite 294
Detailed overview of all applications as of page 294

Hauptanwendungen // Main Applications

Einstechen und Profildrehen Grooving and Profiling



Einstechen und Profildrehen innen und außen mit verschiedenen geschliffenen oder gesinterter Schneidengeometrien. Verfügbare Schneidbreiten zwischen 2,0 mm und 6,0 mm mit verschiedenen Eckenradien oder als Vollradiuswerkzeuge.

Internal and external grooving and profiling with different ground or sintered cutting edge geometries. Available cutting edge widths between 2.0 mm and 6.0 mm with different corner radii or as full radius tools.

Gewinden Threading



Schneidwerkzeuge für die Herstellung von metrischen ISO-Teil- und Vollprofil Gewinden außen sowie für Whitworth-Gewinde innen. Werkzeuge für weitere Gewindearten können auf Anfrage angeboten werden.

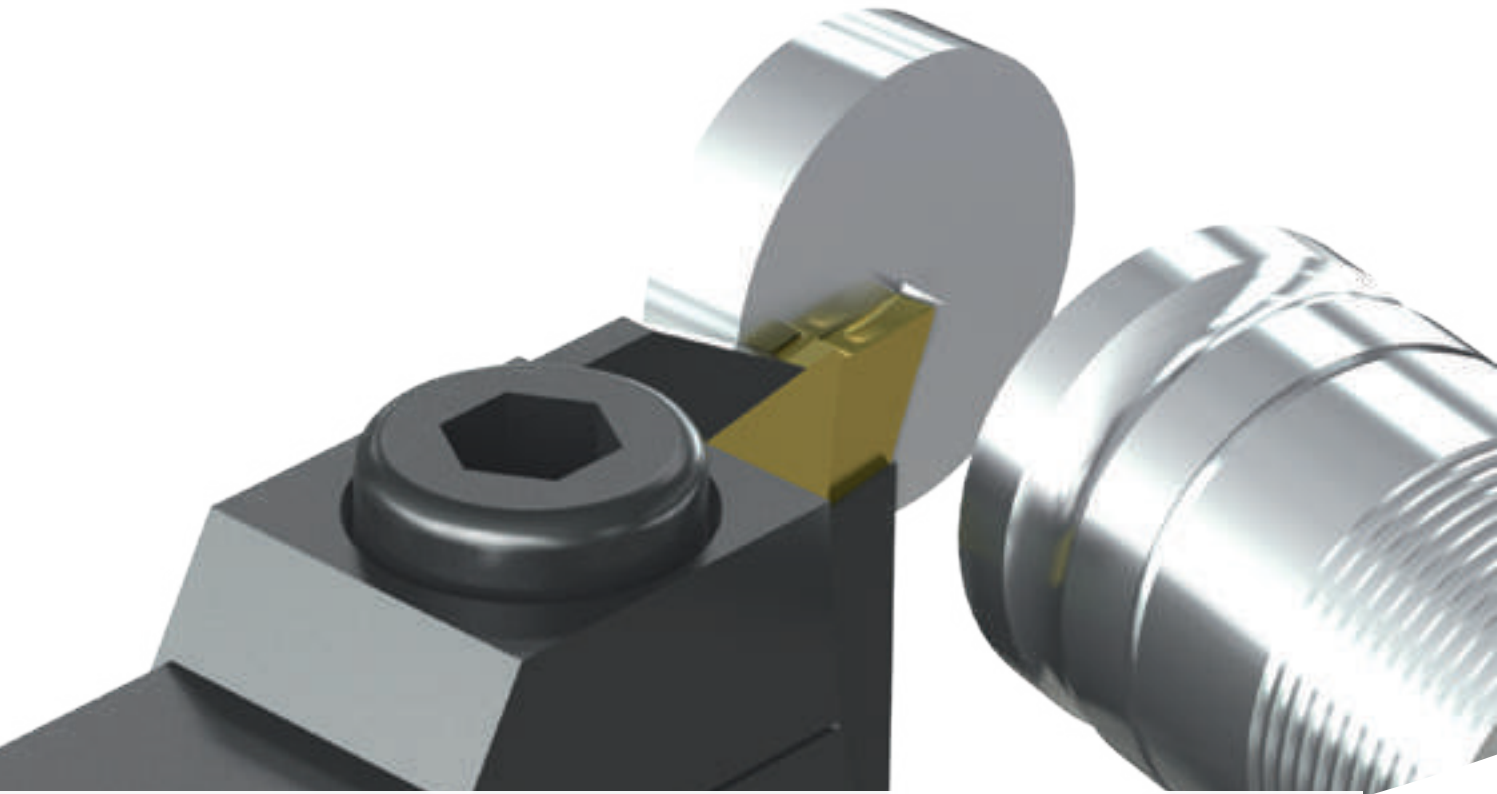
Cutting tools for the machining of external metric ISO partial and full profile threads and internal Whitworth threads. Tools for other thread types can be offered on request.

Abstechen Parting-Off



Abstechen mit verschiedenen Schneidbreiten und -winkeln. Kontrollierte Spanbildung dank gesinterter Spanformgeometrie. Mit simturn GX Trägerwerkzeugen können Bauteile mit einem maximalen Durchmesser von 52,0 mm abgestochen werden.

Parting-off with different cutting edge widths and front angles. Improved chip control thanks to sintered chip forming geometry. simturn GX toolholders enable parting-off of components with a maximum diameter of 52.0 mm.



Werkzeugsystem bestehend aus zweischneidiger Hartmetall-Schneidplatte und stabilen Trägerwerkzeugen. Möglichen Stechtiefen bis 26,0 mm bei der Außenbearbeitung. Verschiedene geschliffene und gesinterte Spanformgeometrien verfügbar.

Tool system of carbide cutting insert with two cutting edges and strong toolholders for demanding applications. Possible depths of cut up to 26,0 mm for external applications. Different ground and sintered cutting edge geometries available.

Modulare Einsatzmöglichkeit Use on modular tool systems



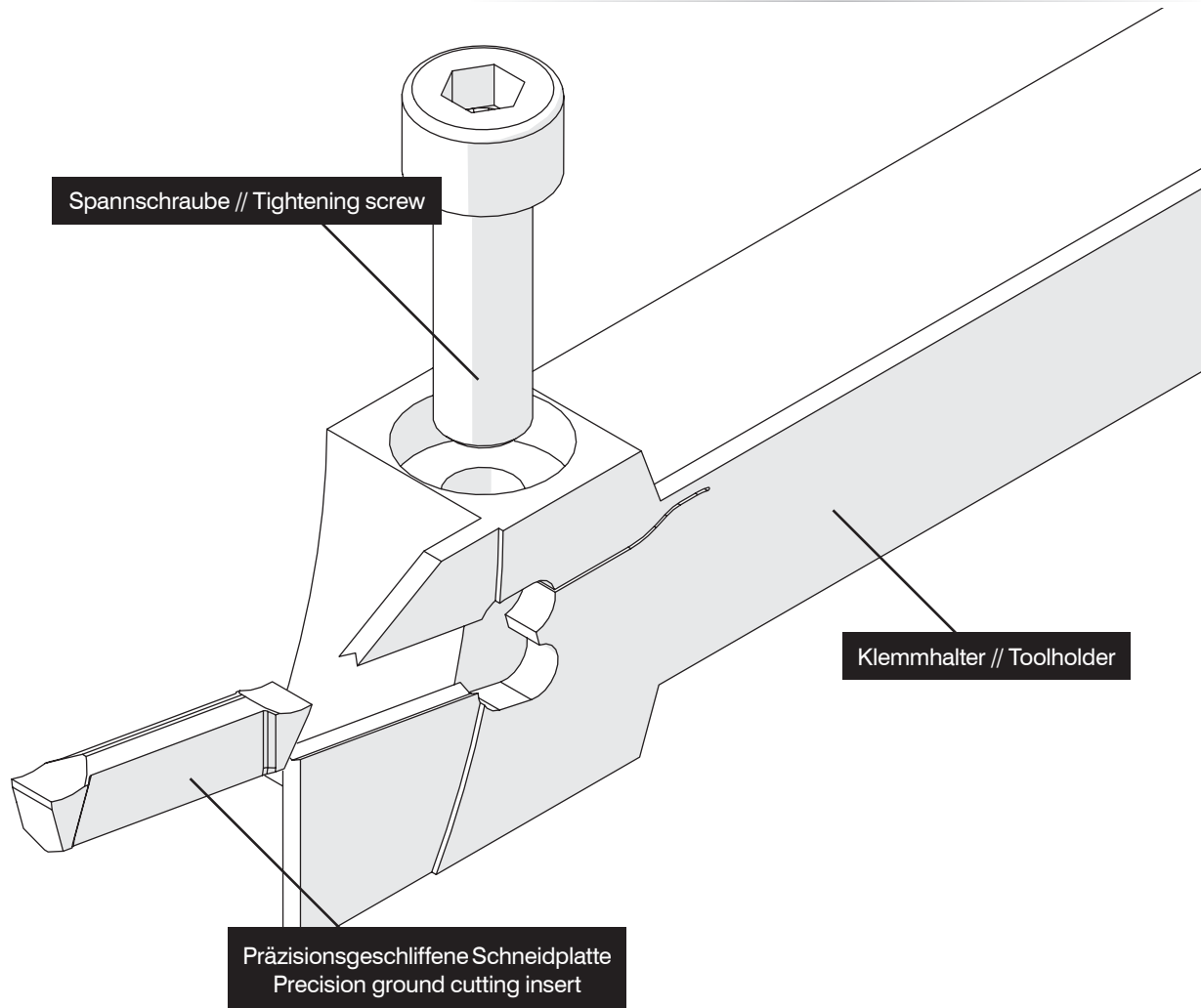
simturn GX bietet verschiedene Kassettenausführungen für den Einsatz auf modularen Werkzeugsystemen, wie dem System simturn OA mit Grundhaltern mit Polygonschaft nach ISO 26623.

simturn GX offers different cassette versions for use on modular tool systems, such as the simturn OA system with basic holders with polygon shank according to ISO 26623.

Das System im Detail The system details

Bitte beachten Sie die allgemeinen Gebrauchshinweise auf Seite
Please read the general instructions for use on page

433



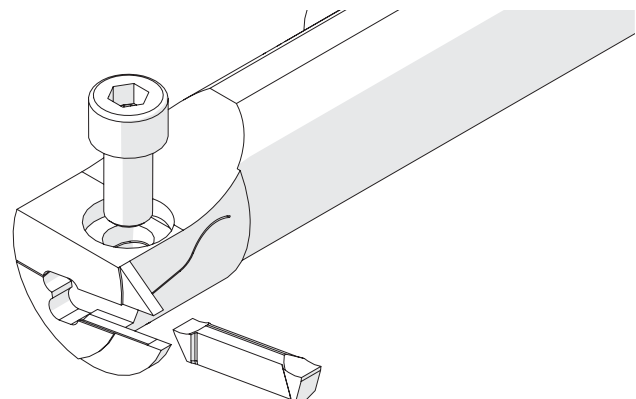
Verfügbar für die Innen- und Außenbearbeitung Available for internal and external applications

Innen // Internal

Ab Bohrungsdurchmesser 38,0 mm
As of bore diameter 38,0 mm

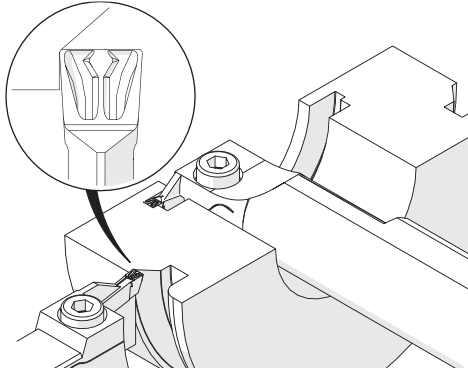
Außen // External

Maximale Stechtiefe 26,0 mm
Maximum cutting depth 26,0 mm

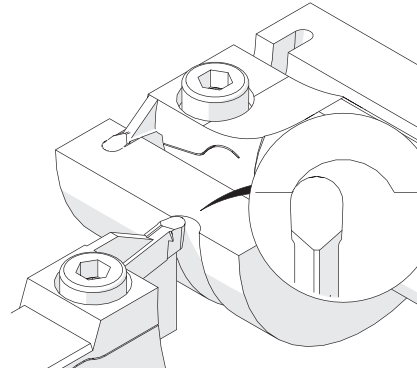


Standardanwendungen
Standard ApplicationsAb Seite
As of Page

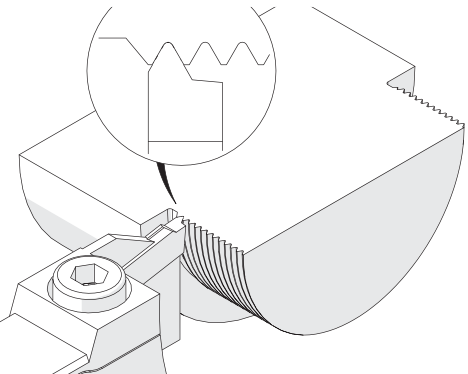
304

Einstechen und Profildrehen
Grooving and ProfilingSeite
Page

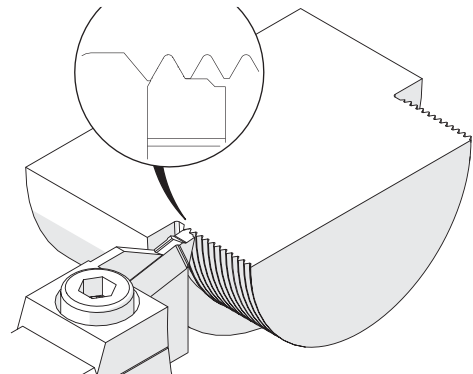
308

Einstechen und Profildrehen, Vollradius
Grooving and Profiling, Full RadiusSeite
Page

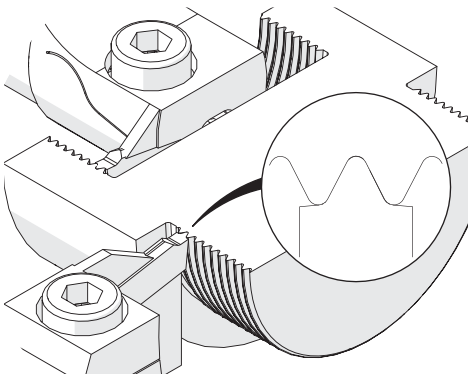
309

Gewinden: Metrisch ISO, außen, Teilprofil
Threading: Metric ISO, external, Partial ProfileSeite
Page

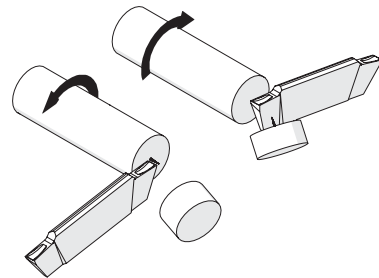
310

Gewinden: Metrisch ISO, außen, Vollprofil
Threading: Metric ISO, external, Full ProfileSeite
Page

311

Gewinden: Whitworth, Vollprofil
Threading: Whitworth, Full ProfileSeite
Page

313

Abstechen
Parting off

Klemmhalter, Außen, Mittlere Stechtiefen

Einstechdrehen und Längsdrehen außen.
 Ausgewogene Balance zwischen Stechtiefe und Stabilität.

Toolholder, External, Regular Cutting Depths

External grooving and turning.
 Well-balanced ratio of cutting depth and stability.

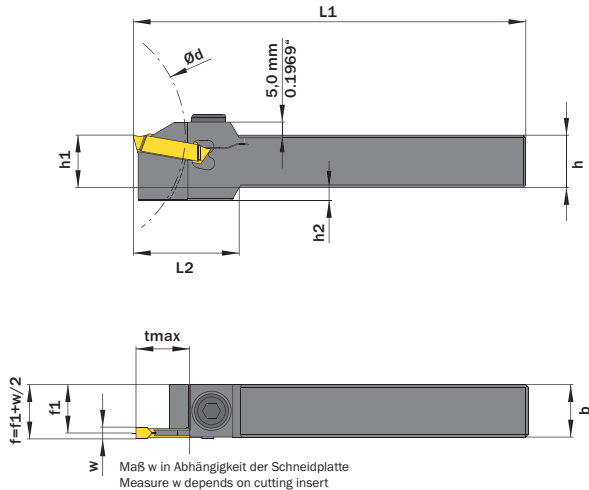
Anzugsmoment (Schraube) // Tightening torque (screw)

12,0 Nm

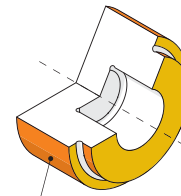


Legende
 Legend **315**

Scan QR-Code Oder besuchen Sie // Or Visit
www.simtek.info/cp/515



tmax in Abhängigkeit vom Werkstückdurchmesser (Ød) tmax depends on workpiece diameter (Ød)	tmax bei / for Schaft bis 25,0 mm Shank up to 0.9843"	tmax bei / for Schaft 32,0 mm Shank 1.2598"
Bis Ø63,0 mm / up to Ø2.4803"	20,0 mm / 0.7874"	20,0 mm / 0.7874"
Bis Ø100,0 mm / up to Ø3.9370"	20,0 mm / 0.7874"	20,0 mm / 0.7874"
Bis Ø160,0 mm / up to Ø6.2992"	18,6 mm / 0.7323"	17,4 mm / 0.6850"
Bis Ø250,0 mm / up to Ø9.8425"	17,1 mm / 0.6732"	14,9 mm / 0.5866"
Bis Ø400,0 mm / up to Ø15.7480"	16,1 mm / 0.6339"	13,3 mm / 0.5236"



- Hauptsächlich geeignet für diese Flächen
 Mainly designed for these surfaces
- Je nach Schneidplatte/Aufnahme ebenfalls möglich
 Also possible depending on insert/fixation type

Abbildung zeigt / Drawing shows: G18.2020.03 R

h	b	w ≥	w ≤	Artikelnummer Part number	Webcode www.simtek.com/webcode	f1	h1 ^{js14}	h2	L1	L2	tmax	Schraube Screw	Schraubenschlüssel Screw driver	Connectcode www.simtek.com/code
mm	mm	mm	mm			mm	mm	mm	mm	mm	mm			
▼ Connectcode = G29.02														
15,875	15,875	2,0	2,9	G18.0.625.02 R/L	R AAS0 L AJ1G	14,88	15,88	9,0	125,0	40,0	20,0	G M8x25 SW6	SW6	G29.02
19,05	19,05	2,0	2,9	G18.0.750.02 R/L	R A3T9 L A3T7	18,05	19,05	6,0	125,0	40,0	20,0	G M8x25 SW6	SW6	G29.02
25,4	25,4	2,0	2,9	G18.1.000.02 R/L	R AWCN L AWCM	24,4	25,4	-	150,0	-	20,0	G M8x25 SW6	SW6	G29.02
16,0	16,0	2,0	2,9	G18.1616.02 R/L	R APV6 L AN1Q	15,0	16,0	9,0	125,0	40,0	20,0	G M8x25 SW6	SW6	G29.02
20,0	20,0	2,0	2,9	G18.2020.02 R/L	R AJX8 L ADGW	19,0	20,0	5,0	125,0	40,0	20,0	G M8x25 SW6	SW6	G29.02
25,0	25,0	2,0	2,9	G18.2525.02 R/L	R AK6D L AEY4	24,0	25,0	-	150,0	-	20,0	G M8x25 SW6	SW6	G29.02
▼ Connectcode = G29.03														
15,875	15,875	3,0	4,0	G18.0.625.03 R/L	R ADD3 L AAVX	14,32	15,88	9,0	125,0	40,0	20,0	G M8x25 SW6	SW6	G29.03
19,05	19,05	3,0	4,0	G18.0.750.03 R/L	R ADZB L AJQY	17,55	19,05	6,0	125,0	40,0	20,0	G M8x25 SW6	SW6	G29.03
25,4	25,4	3,0	4,0	G18.1.000.03 R/L	R AG8W L AKK8	23,9	25,4	-	150,0	-	20,0	G M8x25 SW6	SW6	G29.03
16,0	16,0	3,0	4,0	G18.1616.03 R/L	R AJW3 L AMND	14,5	16,0	9,0	125,0	40,0	20,0	G M8x25 SW6	SW6	G29.03
20,0	20,0	3,0	4,0	G18.2020.03 R/L	R AN7Y L AF13	18,5	20,0	5,0	125,0	40,0	20,0	G M8x25 SW6	SW6	G29.03
25,0	25,0	3,0	4,0	G18.2525.03 R/L	R AE4N L ABPE	23,5	25,0	-	150,0	-	20,0	G M8x25 SW6	SW6	G29.03
32,0	25,0	3,0	4,0	G18.3225.03 R/L	R AJTX L AB4U	23,5	32,0	-	170,0	-	20,0	G M8x25 SW6	SW6	G29.03

Verwandte Werkzeuge finden Sie auch auf der folgenden Seite!
 Related Items can be found on the following page as well!

Fortgesetzte Tabelle
 Continued Table

Bestellbeispiel // Order example: **G18.2020.03 R** (R = Rechte Ausführung // Right hand version)

simturn AX
 simturn DX
 simturn PX
 simturn H2
 simturn K2
 simturn C4
 simturn GX
 simturn E3
 simturn E12
 simturn FX
 simturn Decolletage
 simturn OA
 Index

Klemmhalter, Außen, Mittlere Stechtiefen

Einstechdrehen und Längsdrehen außen.
 Ausgewogene Balance zwischen Stechtiefe und Stabilität.

Toolholder, External, Regular Cutting Depths

External grooving and turning.
 Well-balanced ratio of cutting depth and stability.

Anzugsmoment (Schraube) // Tightening torque (screw)

12,0 Nm

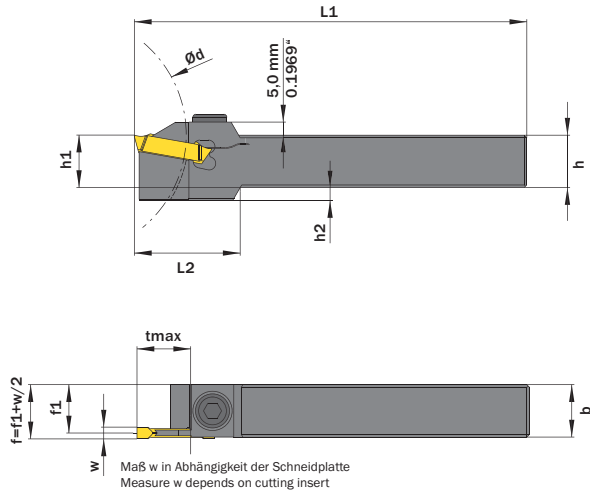


Legende
 Legend **315**

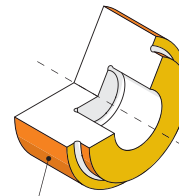


Scan
 QR-Code

Oder besuchen Sie // Or Visit
www.simtek.info/cp/1330



Werkstückdurchmesser (Ød) workpiece diameter (Ød)	tmax bei / for Shank up to 0.9843"	tmax bei / for Shank 1.2598"
Bis Ø63,0 mm / up to Ø2.4803"	20,0 mm / 0.7874"	20,0 mm / 0.7874"
Bis Ø100,0 mm / up to Ø3.9370"	20,0 mm / 0.7874"	20,0 mm / 0.7874"
Bis Ø160,0 mm / up to Ø6.2992"	18,6 mm / 0.7323"	17,4 mm / 0.6850"
Bis Ø250,0 mm / up to Ø9.8425"	17,1 mm / 0.6732"	14,9 mm / 0.5866"
Bis Ø400,0 mm / up to Ø15.7480"	16,1 mm / 0.6339"	13,3 mm / 0.5236"



- Hauptsächlich geeignet für diese Flächen
 Mainly designed for these surfaces
- Je nach Schneidplatte/Aufnahme ebenfalls möglich
 Also possible depending on insert/fixation type

Abbildung zeigt / Drawing shows: G18.2020.03 R

h	b	w ≥	w ≤	Artikelnummer Part number	Webcode www.simtek.com/webcode	f1	h1 ^{js14}	h2	L1	L2	tmax	Schraube Screw	Schraubenschlüssel Screw driver	Connectcode www.simtek.com/code
mm	mm	mm	mm			mm	mm	mm	mm	mm	mm			

Fortgesetzte Tabelle
 Continued Table

Verwandte Werkzeuge finden Sie auch auf der vorhergehenden Seite!
 Related items can be found on the previous page as well!

▼ Connectcode = G29.04															
15,875	15,875	4,0	5,0	G18.0.625.04 R	A35H	13,88	16,0	9,0	125,0	40,0	20,0	G M8x25 SW6	SW6	G29.04	new
19,05	19,05	4,0	5,1	G18.0.750.04 R/L	R AWCH L AWCG	17,05	19,0	6,0	125,0	40,0	20,0	G M8x25 SW6	SW6	G29.04	inch
25,4	25,4	4,0	5,1	G18.1.000.04 R/L	R AWCQ L AWCP	23,4	25,0	-	150,0	-	20,0	G M8x25 SW6	SW6	G29.04	inch
20,0	20,0	4,0	5,0	G18.2020.04 R/L	R AFMZ L ADK3	18,0	20,0	5,0	125,0	40,0	20,0	G M8x25 SW6	SW6	G29.04	
25,0	25,0	4,0	5,1	G18.2525.04 R/L	R AM24 L ANPK	23,0	25,0	-	150,0	-	20,0	G M8x25 SW6	SW6	G29.04	
32,0	25,0	4,0	5,1	G18.3225.04 R/L	R AH22 L AKK5	23,0	32,0	-	170,0	-	20,0	G M8x25 SW6	SW6	G29.04	
▼ Connectcode = G29.06															
19,05	19,05	5,2	6,0	G18.0.750.06 R/L	R AWCK L AWJC	16,05	19,0	6,0	125,0	40,0	20,0	G M8x25 SW6	SW6	G29.06	inch
25,4	25,4	5,2	6,0	G18.1.000.06 R/L	R AWCT L AWCS	22,4	25,0	-	150,0	-	20,0	G M8x25 SW6	SW6	G29.06	inch
20,0	20,0	5,2	6,0	G18.2020.06 R/L	R ACNE L ACEA	17,0	20,0	5,0	125,0	40,0	20,0	G M8x25 SW6	SW6	G29.06	
25,0	25,0	5,2	6,0	G18.2525.06 R/L	R ABN5 L ADJG	22,0	25,0	-	150,0	-	20,0	G M8x25 SW6	SW6	G29.06	
32,0	25,0	5,2	6,0	G18.3225.06 R/L	R AE9N L APHE	22,0	32,0	-	170,0	-	20,0	G M8x25 SW6	SW6	G29.06	

Bestellbeispiel // Order example: **G18.2020.04 R** (R = Rechte Ausführung // Right hand version)

Kassette für Modulares Werkzeugsystem TOA

Geeignet für SIMTEK Grundhalter mit Polygonschaft nach ISO 26623.

Cassette for Modular Tool System TOA

For use on SIMTEK base toolholder with polygon shank according to ISO 26623.

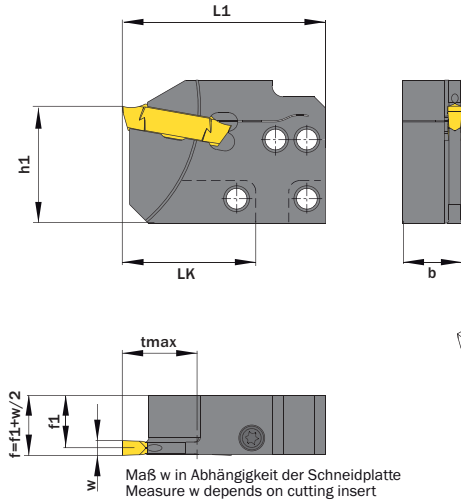
Anzugsmoment (Schraube) // Tightening torque (screw)

7,0 Nm

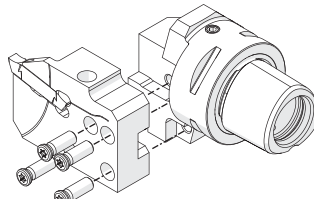


Legende
 Legend **315**

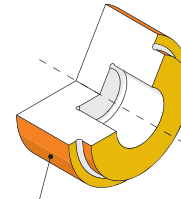
Scan QR-Code Oder besuchen Sie // Or Visit www.simtek.info/cp/1182



Grundhalter finden Sie ab Seite 425
Base toolholder can be found on page 425



Schrauben für Kassettenbefestigung
 Screw for cassette mounting
T M5x15 T20R



- Hauptsächlich geeignet für diese Flächen
 Mainly designed for these surfaces
- Je nach Schneidplatte/Aufnahme ebenfalls möglich
 Also possible depending on insert/fixation type

Abbildung zeigt / Drawing shows: TOA.G18.36.04 R

w ≥	w ≤	Artikelnummer Part number	Webcode www.simtek.com/webcode	b	f1	h1	LK	L1	tmax	Schraube Screw	Schraubenschlüssel Screw driver	Connectcode www.simtek.com/ccode	Adaptcode Adaptcode
mm	mm			mm	mm	mm	mm	mm	mm				
▼ Connectcode = G29.02													
2,0	2,9	TOA.G18.36.02 R/L	R AZA4 L AZA3	16,0	15,05	31,6	36,0	54,9	20,0	G M5x16 T20T	T20T	G29.02	TOA
▼ Connectcode = G29.03													
3,0	4,0	TOA.G18.36.03 R/L	R AZA6 L AZA5	16,0	14,7	31,6	36,0	54,9	20,0	G M5x16 T20T	T20T	G29.03	TOA
▼ Connectcode = G29.04													
4,0	5,1	TOA.G18.36.04 R/L	R AZA8 L AZA7	16,0	14,2	31,6	36,0	54,9	20,0	G M5x16 T20T	T20T	G29.04	TOA
▼ Connectcode = G29.06													
5,2	6,0	TOA.G18.36.06 R/L	R AZBA L AZA9	16,0	13,25	31,6	36,0	54,9	20,0	G M5x16 T20T	T20T	G29.06	TOA

Bestellbeispiel // Order example: **TOA.G18.36.02 R** (R = Rechte Ausführung // Right hand version)

simturn AX
 simturn DX
 simturn PX
 simturn H2
 simturn K2
 simturn C4
simturn GX
 simturn E3
 simturn E12
 simturn FX
 simturn Decolletage
 simturn OA
 Index

Klemmhalter, Außen, Maximale Stechtiefen

Einstechdrehen außen. Für maximale Stechtiefen.

Toolholder, External, Maximum Cutting Depths

External grooving. Maximum depth of cut.

Anzugsmoment (Schraube) // Tightening torque (screw)

12,0 Nm



TW
ST

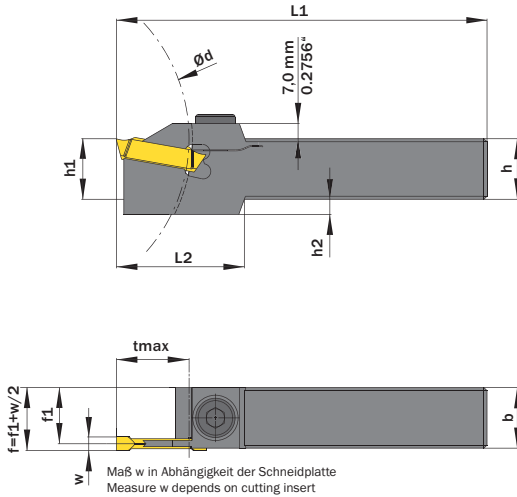
R

Legende
 Legend **315**

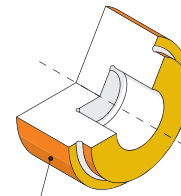


Scan
 QR-Code

Oder besuchen Sie // Or Visit
www.simtek.info/cp/516



Werkstückdurchmesser (Ød) workpiece diameter (Ød)	tmax bei / for Shank up to 0.9843"	tmax bei / for Shank 1.2598"
Bis Ø63,0 mm / up to Ø2.4803"	26,0 mm / 1.0236"	26,0 mm / 1.0236"
Bis Ø100,0 mm / up to Ø3.9370"	20,4 mm / 0.8031"	11,7 mm / 0.4606"
Bis Ø160,0 mm / up to Ø6.2992"	17,7 mm / 0.6969"	7,3 mm / 0.2874"
Bis Ø250,0 mm / up to Ø9.8425"	16,2 mm / 0.6378"	5,0 mm / 0.1969"
Bis Ø400,0 mm / up to Ø15.7480"	15,2 mm / 0.5984"	3,5 mm / 0.1378"



- Hauptsächlich geeignet für diese Flächen
 Mainly designed for these surfaces
- Je nach Schneidplatte/Aufnahme ebenfalls möglich
 Also possible depending on insert/fixation type

Abbildung zeigt / Drawing shows: G26.2020.03 R

h	b	w ≥	w ≤	Artikelnummer Part number	Webcode www.simtek.com/webcode	f1	h1 ^{js14}	h2	L1	L2	tmax	Schraube Screw	Schraubenschlüssel Screw driver	Connectcode www.simtek.com/code		
															mm	mm
▼ Connectcode = G29.02																
16,0	16,0	2,0	2,9	G26.1616.02 R/L	R AFNJ L AG77	15,0	16,0	9,0	125,0	44,0	26,0	G M8x25 SW6	SW6	G29.02		
20,0	20,0	2,0	2,9	G26.2020.02 R/L	R APPM L AB6T	19,0	20,0	7,0	125,0	44,0	26,0	G M8x25 SW6	SW6	G29.02	upd	
25,0	25,0	2,0	2,9	G26.2525.02 R/L	R AEN2 L AA9J	24,0	25,0	-	150,0	-	26,0	G M8x25 SW6	SW6	G29.02		
▼ Connectcode = G29.03																
25,4	25,4	3,0	4,0	G26.1.000.03 R/L	R A35N L A35Q	23,9	25,4	-	150,0	-	26,0	G M8x25 SW6	SW6	G29.03	new	inch
31,75	31,75	3,0	4,0	G26.1.250.03 R	A6EK	23,5	32,0	-	170,0	-	26,0	G M8x25 SW6	SW6	G29.03	new	inch
16,0	16,0	3,0	4,0	G26.1616.03 R/L	R AMDX L AF5A	14,5	16,0	9,0	125,0	44,0	26,0	G M8x25 SW6	SW6	G29.03		
20,0	20,0	3,0	4,0	G26.2020.03 R/L	R AMUV L AAFZ	18,5	20,0	7,0	125,0	44,0	26,0	G M8x25 SW6	SW6	G29.03	upd	
25,0	25,0	3,0	4,0	G26.2525.03 R/L	R AHT2 L ANW0	23,5	25,0	-	150,0	-	26,0	G M8x25 SW6	SW6	G29.03		
32,0	25,0	3,0	4,0	G26.3225.03 R/L	R AKGD L ABNG	23,5	32,0	-	170,0	-	26,0	G M8x25 SW6	SW6	G29.03		
▼ Connectcode = G29.04																
25,4	25,4	4,0	5,1	G26.1.000.04 R/L	R A3A2 L A3A3	23,4	25,4	-	150,0	-	26,0	G M8x25 SW6	SW6	G29.04	new	inch
31,75	31,75	4,0	5,1	G26.1.250.04 R	A6EN	23,0	32,0	-	170,0	-	26,0	G M8x25 SW6	SW6	G29.04	new	inch
20,0	20,0	4,0	5,1	G26.2020.04 R/L	R AF22 L AC73	18,0	20,0	7,0	125,0	44,0	26,0	G M8x25 SW6	SW6	G29.04	upd	
25,0	25,0	4,0	5,1	G26.2525.04 R/L	R AHU2 L AB1C	23,0	25,0	-	150,0	-	26,0	G M8x25 SW6	SW6	G29.04		
32,0	25,0	4,0	5,1	G26.3225.04 R/L	R AH65 L AHXK	23,0	32,0	-	170,0	-	26,0	G M8x25 SW6	SW6	G29.04		
▼ Connectcode = G29.06																
31,75	31,75	5,2	6,0	G26.1.250.06 R	A6EQ	23,0	32,0	-	170,0	-	26,0	G M8x25 SW6	SW6	G29.06	new	inch
25,0	25,0	5,2	6,0	G26.2525.06 R/L	R AAX3 L AC8S	22,0	25,0	-	150,0	-	26,0	G M8x25 SW6	SW6	G29.06		

Bestellbeispiel // Order example: **G26.2525.03 R** (R = Rechte Ausführung // Right hand version)

Kassette für Modulares Werkzeugsystem TOA

Geeignet für SIMTEK Grundhalter mit Polygonschaft nach ISO 26623.

Cassette for Modular Tool System TOA

For use on SIMTEK base toolholder with polygon shank according to ISO 26623.

Anzugsmoment (Schraube) // Tightening torque (screw)

7,0 Nm

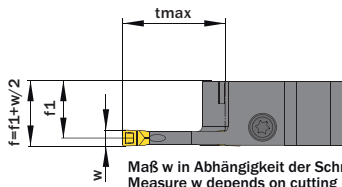
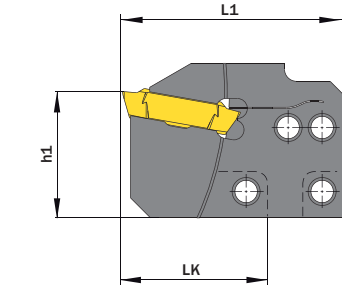


Legende
 Legend **315**

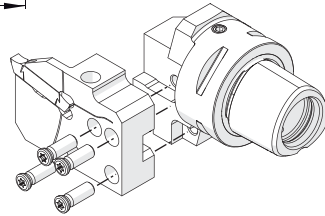


Scan
 QR-Code

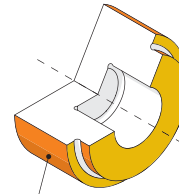
Oder besuchen Sie // Or Visit
www.simtek.info/cp/1177



Maß w in Abhängigkeit der Schneidplatte
 Measure w depends on cutting insert



Schrauben für Kassettenbefestigung
 Screw for cassette mounting
T M5x15 T20R



- Hauptsächlich geeignet für diese Flächen
 Mainly designed for these surfaces
- Je nach Schneidplatte/Aufnahme ebenfalls möglich
 Also possible depending on insert/fixation type

Abbildung zeigt / Drawing shows: TOA.G25.36.04 R

w ≥	w ≤	Artikelnummer Part number	Webcode www.simtek.com/webcode		b	f1	h1	L1	tmax	LK	Schraube Screw	Schraubenschlüssel Screw driver	Connectcode www.simtek.com/ccode	Adaptcode Adaptcode
mm	mm		R AZBC	L AZBB										
4,0	5,1	TOA.G25.36.04 R/L	R	AZBC	16,0	14,2	31,6	54,9	25,0	36,0	G M5x15 T20T	T20T	G29.04	TOA

Bestellbeispiel // Order example: **TOA.G25.36.04 R** (R = Rechte Ausführung // Right hand version)

simturn AX
 simturn DX
 simturn PX
 simturn H2
 simturn K2
 simturn C4
simturn GX
 simturn E3
 simturn E12
 simturn FX
 simturn Decolletage
 simturn OA
 Index

Klemmhalter, Außen, Höchste Stabilität

Einstechdrehen und Längsdrehen außen.
 Reduzierte Stechtiefe für höchste Stabilität.

Toolholder, External, Highest Stability

External grooving and turning. Reduced depth of cut for best stability.

Anzugsmoment (Schraube) // Tightening torque (screw)

12,0 Nm

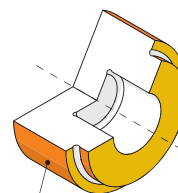
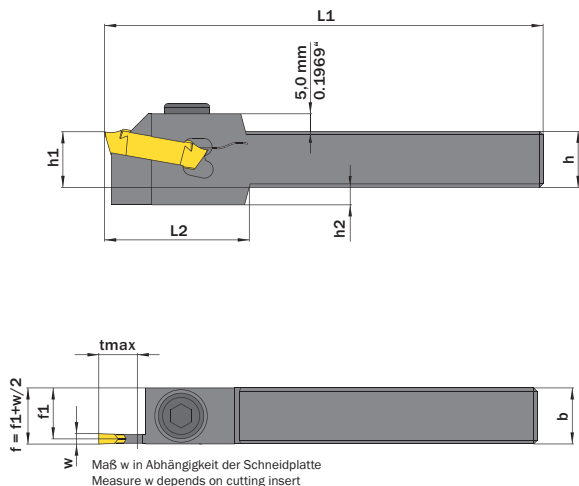


Legende
 Legend 315



Scan
 QR-Code

Oder besuchen Sie // Or Visit
www.simtek.info/cp/527



- Hauptsächlich geeignet für diese Flächen
 Mainly designed for these surfaces
- Je nach Schneidplatte/Aufnahme ebenfalls möglich
 Also possible depending on insert/fixation type

Abbildung zeigt / Drawing shows: G10.1616.03 R

h	b	w ≥	w ≤	Artikelnummer Part number	Webcode www.simtek.com/webcode	f1	h1 ^{js14}	h2	L1	L2	tmax	Schraube Screw	Schraubenschlüssel Screw driver	Connectcode www.simtek.com/code	
						mm	mm	mm	mm	mm	mm				
▼ Connectcode = G29.02															
16,0	16,0	2,0	2,9	G10.1616.02 R/L	R AHUF L ADUC	15,0	16,0	9,0	125,0	35,0	11,0	G M8x25 SW6	SW6	G29.02	upd
20,0	20,0	2,0	2,9	G10.2020.02 R/L	R AFA4 L AKB7	19,0	20,0	5,0	125,0	35,0	11,0	G M8x25 SW6	SW6	G29.02	upd
25,0	25,0	2,0	2,9	G10.2525.02 R/L	R AF59 L AMG5	24,0	25,0	-	150,0	-	11,0	G M8x25 SW6	SW6	G29.02	upd
▼ Connectcode = G29.03															
16,0	16,0	3,0	4,0	G10.1616.03 R/L	R ABYD L AA1Q	14,5	16,0	9,0	125,0	35,0	11,0	G M8x25 SW6	SW6	G29.03	upd
20,0	20,0	3,0	4,0	G10.2020.03 R/L	R AKKG L AMZF	18,5	20,0	5,0	125,0	35,0	11,0	G M8x25 SW6	SW6	G29.03	upd
25,0	25,0	3,0	4,0	G10.2525.03 R/L	R AHY4 L AMWS	23,5	25,0	-	150,0	-	11,0	G M8x25 SW6	SW6	G29.03	Upd
32,0	25,0	3,0	4,0	G10.3225.03 R/L	R AX4J L AX4H	23,5	32,0	-	170,0	-	11,0	G M8x25 SW6	SW6	G29.03	upd
▼ Connectcode = G29.04															
16,0	16,0	4,0	5,1	G10.1616.04 R/L	R AB68 L AFUD	14,0	16,0	9,0	125,0	35,0	11,0	G M8x25 SW6	SW6	G29.04	upd
20,0	20,0	4,0	5,1	G10.2020.04 R/L	R AG85 L AE7N	18,0	20,0	5,0	125,0	35,0	11,0	G M8x25 SW6	SW6	G29.04	
25,0	25,0	4,0	5,1	G10.2525.04 R/L	R AJHC L ANMQ	23,0	25,0	-	150,0	-	11,0	G M8x25 SW6	SW6	G29.04	upd
32,0	25,0	4,0	5,1	G10.3225.04 R/L	R AX4K L AX4M	23,0	32,0	-	170,0	-	11,0	G M8x25 SW6	SW6	G29.04	upd
▼ Connectcode = G29.06															
25,4	25,4	5,2	6,0	G10.1.000.06 R	A3V7	22,4	25,4	-	150,0	-	11,0	G M8x25 SW6	SW6	G29.06	new
20,0	20,0	5,2	6,0	G10.2020.06 R/L	R ADHN L AA1K	17,0	20,0	5,0	125,0	35,0	11,0	G M8x25 SW6	SW6	G29.06	upd
25,0	25,0	5,2	6,0	G10.2525.06 R/L	R ANQ7 L ACZC	22,0	25,0	-	150,0	-	11,0	G M8x25 SW6	SW6	G29.06	upd
32,0	25,0	5,2	6,0	G10.3225.06 R/L	R AX4P L AX4N	22,0	32,0	-	170,0	-	11,0	G M8x25 SW6	SW6	G29.06	upd

Bestellbeispiel // Order example: **G10.2525.04 R** (R = Rechte Ausführung // Right hand version)

Kassette für Modulares Werkzeugsystem TOA

Geeignet für SIMTEK Grundhalter mit Polygonschaft nach ISO 26623.

Cassette for Modular Tool System TOA

For use on SIMTEK base toolholder with polygon shank according to ISO 26623.

Anzugsmoment (Schraube) // Tightening torque (screw)

7,0 Nm

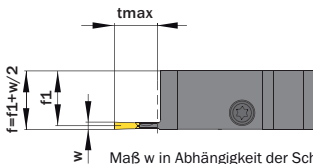
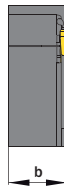
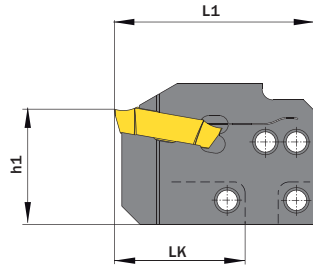


Legende
 Legend **315**

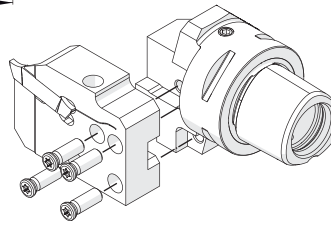


Scan QR-Code

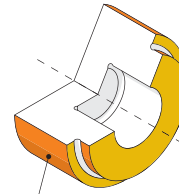
Oder besuchen Sie // Or Visit www.simtek.info/cp/1181



Maß w in Abhängigkeit der Schneidplatte
 Measure w depends on cutting insert



Schrauben für Kassettenbefestigung
 Screw for cassette mounting
T M5x15 T20R



■ Hauptsächlich geeignet für diese Flächen
 Mainly designed for these surfaces

■ Je nach Schneidplatte/Aufnahme ebenfalls möglich
 Also possible depending on insert/fixation type

Abbildung zeigt / Drawing shows: TOA.G10.36.02 R

w ≥ mm	w ≤ mm	Artikelnummer Part number	Webcode www.simtek.com/webcode	b	f1	h1	LK	L1	tmax	Schraube Screw	Schraubenschlüssel Screw driver	Connectcode www.simtek.com/cp/code	Adaptcode Adaptcode
▼ Connectcode = G29.02													
2,0	2,9	TOA.G10.36.02 R/L	R AZAW L AZAV	16,0	15,05	31,6	36,0	54,9	11,0	G M5x12 T20T	T20T	G29.02	TOA R/L
▼ Connectcode = G29.03													
3,0	4,0	TOA.G10.36.03 R/L	R AZAY L AZAX	16,0	14,7	31,6	36,0	54,9	11,0	G M5x12 T20T	T20T	G29.03	TOA R/L
▼ Connectcode = G29.04													
4,0	5,1	TOA.G10.36.04 R/L	R AZA0 L AZAZ	16,0	14,2	31,6	36,0	54,9	11,0	G M5x12 T20T	T20T	G29.04	TOA R/L
▼ Connectcode = G29.06													
5,2	6,0	TOA.G10.36.06 R/L	R AZA2 L AZA1	16,0	13,25	31,6	36,0	54,9	11,0	G M5x12 T20T	T20T	G29.06	TOA R/L

Bestellbeispiel // Order example: **TOA.G10.36.02 R** (R = Rechte Ausführung // Right hand version)

simturn AX
 simturn DX
 simturn PX
 simturn H2
 simturn K2
 simturn C4
simturn GX
 simturn E3
 simturn E12
 simturn FX
 simturn Decolletage
 simturn OA
 Index

Klemmhalter, Innen, Längsausführung

Einstechdrehen und Längsdrehen innen.

Toolholder, Internal, Long Version

Internal grooving and turning.

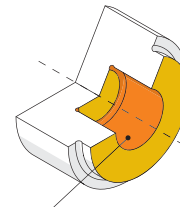
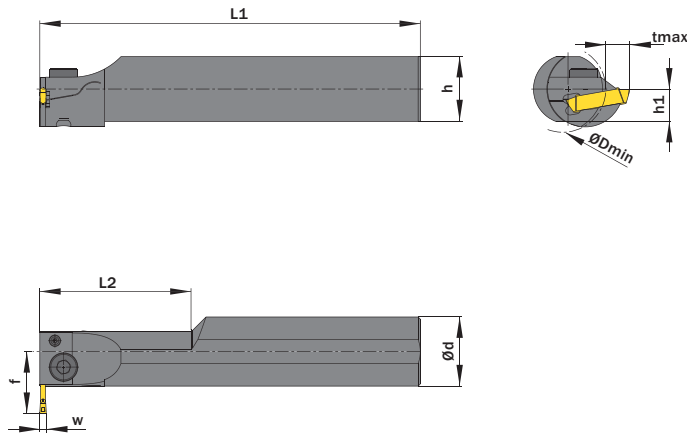
Anzugsmoment (Schraube) // Tightening torque (screw)

12,0 Nm



TW **ST** **R** Legende **315**
 Legend

Scan QR-Code Oder besuchen Sie // Or Visit www.simtek.info/cp/518



- Hauptsächlich geeignet für diese Flächen
Mainly designed for these surfaces
- Je nach Schneidplatte ebenfalls möglich
Also possible depending on insert type

Abbildung zeigt / Drawing shows: G14.0032.03 R

Ød ^{g6} mm	w ≥ mm	w ≤ mm	Artikelnummer Part number	Webcode www.simtek.com/webcode	ØDmin (Min. Bohrung) ØDmin (min. bore)	f mm	h mm	h1 ^{is14} mm	L1 mm	L2 mm	tmax mm	Schraube Screw	Schraubenschlüssel Screw driver	Connectcode www.simtek.com/code
▼ Connectcode = G29.02														
32,0	2,0	2,9	G14.0032.02 R/L	R AGAF L AAPV	40,0	28,0	30,0	15,0	200,0	70,0	11,0	G M8x16 SW6	SW6	G29.02
▼ Connectcode = G29.03														
32,0	3,0	4,0	G14.0032.03 R/L	R AD7N L ANU3	40,0	28,0	30,0	15,0	200,0	70,0	11,0	G M8x16 SW6	SW6	G29.03
40,0	3,0	4,0	G14.0040.03 R/L	R ACQK L AP3M	50,0	32,0	38,0	19,0	250,0	80,0	11,0	G M8x16 SW6	SW6	G29.03
50,0	3,0	4,0	G14.0050.03 R/L	R AM2B L ADAK	60,0	40,5	47,0	23,5	250,0	100,0	15,0	G M8x16 SW6	SW6	G29.03
▼ Connectcode = G29.04														
32,0	4,0	5,1	G14.0032.04 R/L	R AGAV L AC29	40,0	28,0	30,0	15,0	200,0	70,0	11,0	G M8x16 SW6	SW6	G29.04
40,0	4,0	5,1	G14.0040.04 R/L	R AN0C L AEKS	50,0	32,0	38,0	19,0	250,0	80,0	11,0	G M8x16 SW6	SW6	G29.04
50,0	4,0	5,1	G14.0050.04 R/L	R ADET L ANCK	60,0	40,5	47,0	23,5	250,0	100,0	15,0	G M8x16 SW6	SW6	G29.04
▼ Connectcode = G29.06														
32,0	5,2	6,0	G14.0032.06 R/L	R ADZY L AFXG	40,0	28,0	30,0	15,0	200,0	70,0	11,0	G M8x16 SW6	SW6	G29.06
40,0	5,2	6,0	G14.0040.06 R/L	R AA6Q L AHTW	50,0	32,0	38,0	19,0	250,0	80,0	11,0	G M8x16 SW6	SW6	G29.06
50,0	5,2	6,0	G14.0050.06 R/L	R ANV3 L AN1J	60,0	40,5	47,0	23,5	250,0	100,0	15,0	G M8x16 SW6	SW6	G29.06

Bestellbeispiel // Order example: **G14.0032.03 R** (R = Rechte Ausführung // Right hand version)

Klemmhalter, Innen, Kurzausführung

Einstechdrehen und Längsdrehen innen.

Toolholder, Internal, Short Version

Internal grooving and turning.

Anzugsmoment (Schraube) // Tightening torque (screw)

"G M5x16 T20T": 7,0 Nm
 "G M8x16 SW6": 12,0 Nm

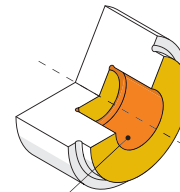
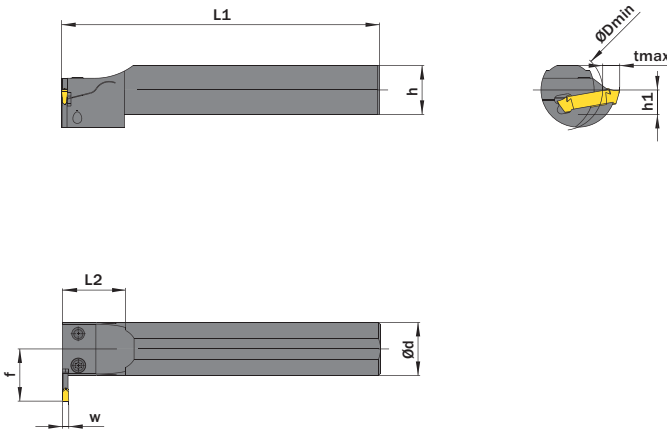


Legende
 Legend **315**



Scan
 QR-Code

Oder besuchen Sie // Or Visit
www.simtek.info/cp/517



- Hauptsächlich geeignet für diese Flächen
 Mainly designed for these surfaces
- Je nach Schneidplatte ebenfalls möglich
 Also possible depending on insert type

Abbildung zeigt / Drawing shows: G13.0025.03 R

Ød ^{G6} mm	w ≥ mm	w ≤ mm	Artikelnummer Part number	Webcode www.simtek.com/webcode	ØDmin (Min. Bohrung) ØDmin (min. bore)	f mm	h mm	h1 ^{is14} mm	L1 mm	L2 mm	tmax mm	Schraube Screw	Schraubenschlüssel Screw driver	Connectcode www.simtek.com/code
▼ Connectcode = G29.03														
25,0	3,0	4,0	G13.0025.03 R/L	R AGA2 L ABW9	38,0	24,5	23,0	11,5	150,0	30,0	11,0	G M5x16 T20T	T20T	G29.03
32,0	3,0	4,0	G13.0032.03 R/L	R ADMW L AKKY	38,0	28,0	30,0	15,0	150,0	30,0	11,0	G M8x16 SW6	SW6	G29.03
40,0	3,0	4,0	G13.0040.03 R/L	R AFKV L AAF7	50,0	32,0	38,0	19,0	180,0	30,0	11,0	G M8x16 SW6	SW6	G29.03
50,0	3,0	4,0	G13.0050.03 R/L	R ABWD L AKHD	60,0	40,5	47,0	23,5	200,0	30,0	15,0	G M8x16 SW6	SW6	G29.03
▼ Connectcode = G29.04														
25,0	4,0	5,1	G13.0025.04 R/L	R ACB9 L AM41	38,0	24,5	23,0	11,5	150,0	30,0	11,0	G M5x16 T20T	T20T	G29.04
32,0	4,0	5,1	G13.0032.04 R/L	R AN4Q L AH0C	38,0	28,0	30,0	15,0	150,0	30,0	11,0	G M8x16 SW6	SW6	G29.04
40,0	4,0	5,1	G13.0040.04 R/L	R AMTN L APHN	50,0	32,0	38,0	19,0	180,0	30,0	11,0	G M8x16 SW6	SW6	G29.04
50,0	4,0	5,1	G13.0050.04 R/L	R ABWN L AC9W	60,0	40,5	47,0	23,5	200,0	30,0	15,0	G M8x16 SW6	SW6	G29.04
▼ Connectcode = G29.06														
32,0	5,2	6,0	G13.0032.06 R/L	R AFEK L AE8Q	38,0	28,0	30,0	15,0	150,0	30,0	11,0	G M8x16 SW6	SW6	G29.06
40,0	5,2	6,0	G13.0040.06 R/L	R AHFN L AKXC	50,0	32,0	38,0	19,0	180,0	30,0	11,0	G M8x16 SW6	SW6	G29.06
50,0	5,2	6,0	G13.0050.06 R/L	R AD53 L AC5C	60,0	40,5	47,0	23,5	200,0	30,0	15,0	G M8x16 SW6	SW6	G29.06

Bestellbeispiel // Order example: **G13.0032.03 R** (R = Rechte Ausführung // Right hand version)

simturn AX
 simturn DX
 simturn PX
 simturn H2
 simturn K2
 simturn C4
simturn GX
 simturn E3
 simturn E12
 simturn FX
 simturn Decolletage
 simturn OA
 Index

Einstecken und Profildrehen

CNC-Konturdrehen mit runder, geschliffener Spanfläche.

Grooving and Profiling

CNC profiling. Ground, round geometry.

Schnittwerte (Start) // Cutting parameters (start)

f (außen//ext.) 0,05 mm/U	f (innen//int.) 0,04 mm/U	Vc Seite/Page 429
-------------------------------------	-------------------------------------	-----------------------------

Passende Klemmhalter auf Seite // Suitable toolholders on page

295, 296, 297, 298, 299, 300, 301, 302, 303



SP Legende
HM Legend

315

Scan
 QR-Code

Oder besuchen Sie // Or Visit
www.simtek.info/cp/519

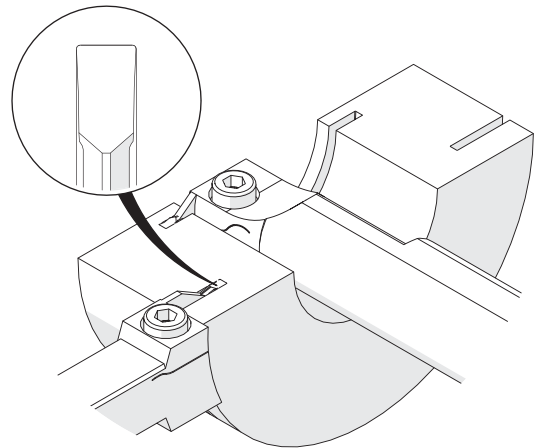
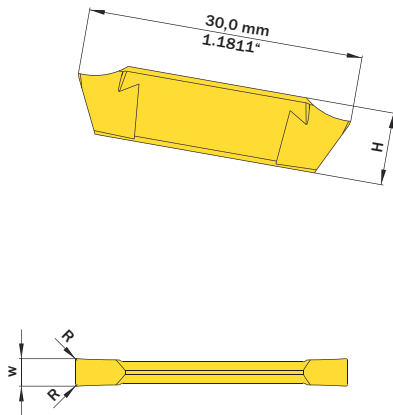


Abbildung zeigt / Drawing shows: G29.0300.10 S

$w^{+0,05}$ mm	Artikelnummer Part number	Webcode www.simtek.com/webcode	Unsere erste Wahl Our first choice	H mm	R mm	Connectcode www.simtek.com/code
2,0	G29.0200.10 S	AH87	P K M N S X800 X600	7,9	0,2	G29.02
2,5	G29.0250.10 S	AG6S	X800 X600	7,9	0,2	G29.02
3,0	G29.0300.10 S	ACA7	X800 X600	7,9	0,2	G29.03
4,0	G29.0400.10 S	AES9	X800 X600	7,9	0,2	G29.03 G29.04
5,0	G29.0500.10 S	AFY3	X800 X600	7,9	0,2	G29.04
6,0	G29.0600.10 S	AJKN	X800 X600	7,5	0,2	G29.06

Bestellbeispiel // Order example: **G29.0300.10 S X800** (X800 = Schneidstoff // Grade)

Einstecken und Profildrehen

CNC-Konturdrehen mit ebener, geschliffener Spanfläche.

Grooving and Profiling

CNC profiling. Ground, flat geometry.

Schnittwerte (Start) // Cutting parameters (start)		
f (außen//ext.) 0,05 mm/U	f (innen//int.) 0,04 mm/U	Vc Seite/Page 429

Passende Klemmhalter auf Seite // Suitable toolholders on page
295, 296, 297, 298, 299, 300, 301, 302, 303

	SP CBN	SP HM	Legende Legend	315
	 Scan QR-Code		Oder besuchen Sie // Or Visit www.simtek.info/cp/520	

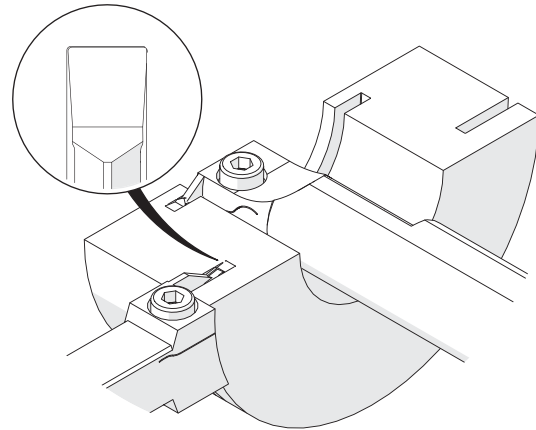
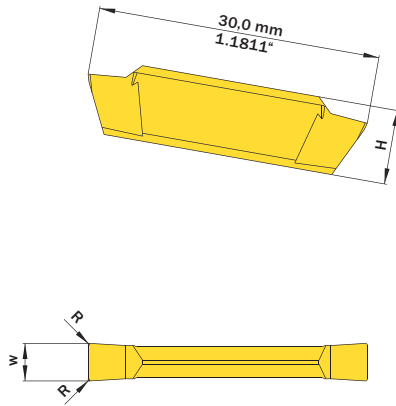


Abbildung zeigt / Drawing shows: G29.0400.20 S

$w^{+0,05}$ mm	Artikelnummer Part number	Webcode www.simtek.com/webcode	Unsere erste Wahl Our first choice	H mm	R mm	Connectcode www.simtek.com/ccode
3,0	G29.0300.20 S	AMDB	P X800 X600	7,9	0,2	G29.03
4,0	G29.0400.20 S	ABMU	X800 X600	7,9	0,2	G29.03 G29.04
5,0	G29.0500.20 S	APU5	X800 X600	7,9	0,2	G29.04
6,0	G29.0600.20 S	AB3V	X800 X600	7,5	0,4	G29.06

Bestellbeispiel // Order example: **G29.0300.20 S X800** (X800 = Schneidstoff // Grade)

simturn AX
 simturn DX
 simturn PX
 simturn H2
 simturn K2
 simturn C4
simturn GX
 simturn E3
 simturn E12
 simturn FX
 simturn Decolletage
 simturn OA
 Index

Einstecken und Profildrehen

CNC-Konturdrehen mit gesinterter Spanformgeometrie für kontrollierte Spanbildung.

Grooving and Profiling

CNC profiling. Sintered geometry for improved chip control.

Schnittwerte (Start) // Cutting parameters (start)		
f (außen//ext.) 0,12 mm/U	f (innen//int.) 0,09 mm/U	Vc Seite/Page 429

Passende Klemmhalter auf Seite // Suitable toolholders on page
295, 296, 297, 298, 299, 300, 301, 302, 303

SP

Legende

HM

Legende

315

Scan QR-Code

Oder besuchen Sie // Or Visit www.simtek.info/cp/521

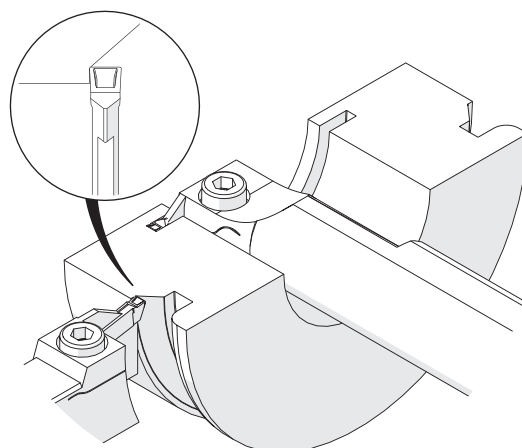
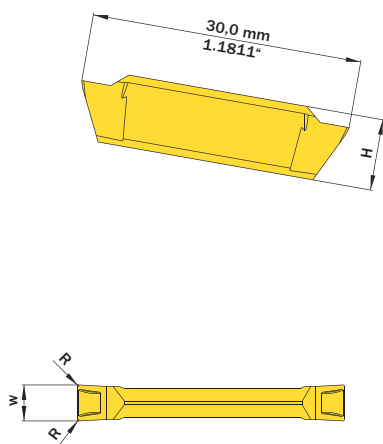


Abbildung zeigt / Drawing shows: G29.0400.32 S

$w^{+0,05}$	R	Artikelnummer Part number	Webcode www.simtek.com/webcode	Unsere erste Wahl Our first choice	H	Connectcode www.simtek.com/code
mm	mm			P K M N S	mm	
2,0	0,2	G29.0200.32 S	ABNM	X800 X600	7,9	G29.02
2,5	0,2	G29.0250.32 S	AHMB	X800 X600	7,9	G29.02
3,0	0,2	G29.0300.32 S	AFPT	X800 X600	7,9	G29.03
3,0	0,4	G29.0300.34 S	AN8A	X800 X600	7,9	G29.03
3,175	0,2	G29.0318.32 S	A6DD	X800 X600	7,9	G29.03
3,175	0,4	G29.0318.34 S	A6DF	X800 X600	7,9	G29.03
4,0	0,2	G29.0400.32 S	AJK1	X800 X600	7,9	G29.03 G29.04
4,0	0,4	G29.0400.34 S	AAE0	X800 X600	7,9	G29.03 G29.04
5,0	0,4	G29.0500.34 S	AN6E	X800 X600	7,9	G29.04
6,0	0,4	G29.0600.34 S	AE8G	X800 X600	7,5	G29.06
6,0	0,8	G29.0600.38 S	ANYA	X800 X600	7,5	G29.06
6,35	0,2	G29.0635.32 S	A6DV	X800 X600	7,5	G29.06
6,35	0,4	G29.0635.34 S	A6DT	X800 X600	7,5	G29.06

Bestellbeispiel // Order example: **G29.0300.34 S X800** (X800 = Schneidstoff // Grade)

Einstecken und Profildrehen

CNC-Konturdrehen mit gesinterter Spanformgeometrie für kontrollierte Spanbildung.

Grooving and Profiling

CNC profiling. Sintered geometry for improved chip control.

Schnittwerte (Start) // Cutting parameters (start)

f (außen//ext.) 0,12 mm/U	f (innen//int.) 0,09 mm/U	Vc Seite/Page 429
-------------------------------------	-------------------------------------	-----------------------------

Passende Klemmhalter auf Seite // Suitable toolholders on page
295, 296, 297, 298, 299, 300, 301, 302, 303

SP

Legende

HM

Legende

Scan

QR-Code

315

Oder besuchen Sie // Or Visit
www.simtek.info/cp/522

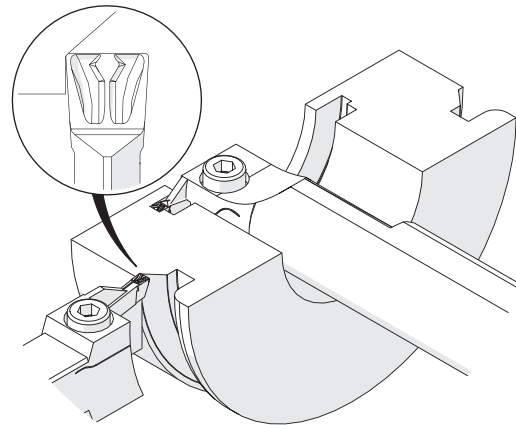
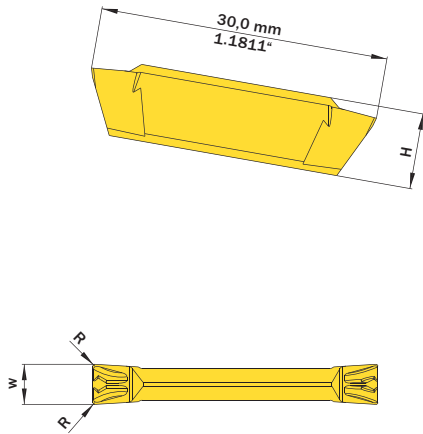


Abbildung zeigt / Drawing shows: G29.0400.52 S

$w_{\pm 0,05}$	R	Artikelnummer Part number	Webcode www.simtek.com/webcode	Unsere erste Wahl Our first choice	H	Connectcode www.simtek.com/ccode
mm	mm			P K M N S	mm	
4,0	0,2	G29.0400.52 S	APMU	X800 X600	7,9	G29.03 G29.04
4,0	0,4	G29.0400.54 S	AF87	X800 X600	7,9	G29.03 G29.04

Bestellbeispiel // Order example: **G29.0400.54 S X800** (X800 = Schneidstoff // Grade)

Einstecken und Profildrehen, Vollradius

Vollradiusnuten, CNC-Konturdrehen.

Grooving and Profiling, Full Radius

Full radius, CNC profiling.

Schnittwerte (Start) // Cutting parameters (start)

f (außen//ext.) 0,05 mm/U	f (innen//int.) 0,04 mm/U	Vc Seite/Page 429
-------------------------------------	-------------------------------------	-----------------------------

Passende Klemmhalter auf Seite // Suitable toolholders on page

295, 296, 297, 298, 299, 300, 301, 302, 303

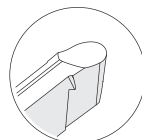
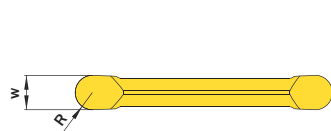
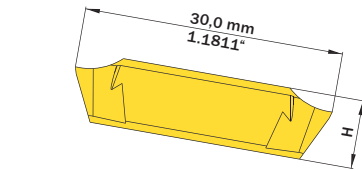


SP Legende
HM Legend

315

Scan
 QR-Code

Oder besuchen Sie // Or Visit
www.simtek.info/cp/523



G29.00 ...S



G29.CB...S

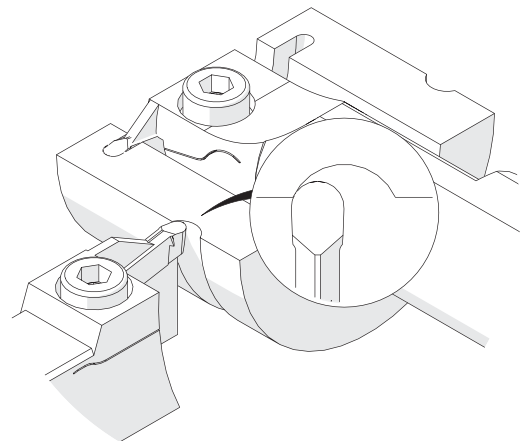


Abbildung zeigt / Drawing shows: G29.0040.20 S

$w^{+0,05}$ mm	R mm	Artikelnummer Part number	Webcode www.simtek.com/webcode	Unsere erste Wahl Our first choice P K M N S	H mm	Connectcode www.simtek.com/ccode
▼ w = 2,0 mm						
2,0	1,0	G29.0020.10 S	ADWN	X800 X600	7,9	G29.02
▼ w = 3,0 mm						
3,0	1,5	G29.0030.15 S	ANAZ	X800 X600	7,9	G29.03
▼ w = 4,0 mm						
4,0	2,0	G29.0040.20 S	AK7N	X800 X600	7,9	G29.03 G29.04
4,0	2,0	G29.CB40.20 S	A2WM	X800 X600	7,9	G29.03 G29.04 <small>upd</small>
▼ w = 5,0 mm						
5,0	2,5	G29.0050.25 S	ANTE	X800 X600	7,9	G29.04
▼ w = 6,0 mm						
6,0	3,0	G29.0060.30 S	AME9	X800 X600	7,5	G29.06
6,0	3,0	G29.CB60.30 S	A172	X800 X600	7,5	G29.06

Bestellbeispiel // Order example: **G29.0030.15 S X800** (X800 = Schneidstoff // Grade)

Gewindedrehen, Metr. ISO, Außen, Teilprofil

Mehrbereichswerkzeuge für verschiedene Steigungen.

Threading, Metr. ISO, External, Partial Profile

Multi-purpose tools, usable for different pitches.

Schnittwerte (Start) // Cutting parameters (start)
Anzahl Durchgänge // Number of passes 8 - 12
Empf. Zustellungsart // Recom. infeed method Flankenzustellung // Flank infeed (Seite/Page 433)
Vc Seite/Page 429
Passende Klemmhalter auf Seite // Suitable toolholders on page 295, 297, 298, 300, 301, 302, 303
Bitte Hinweise im Anhang beachten // Please read add. notes T01 (Seite/Page 314)

SP

HM

R

Legende
Legend **315**

Scan QR-Code Oder besuchen Sie // Or Visit
www.simtek.info/cp/524

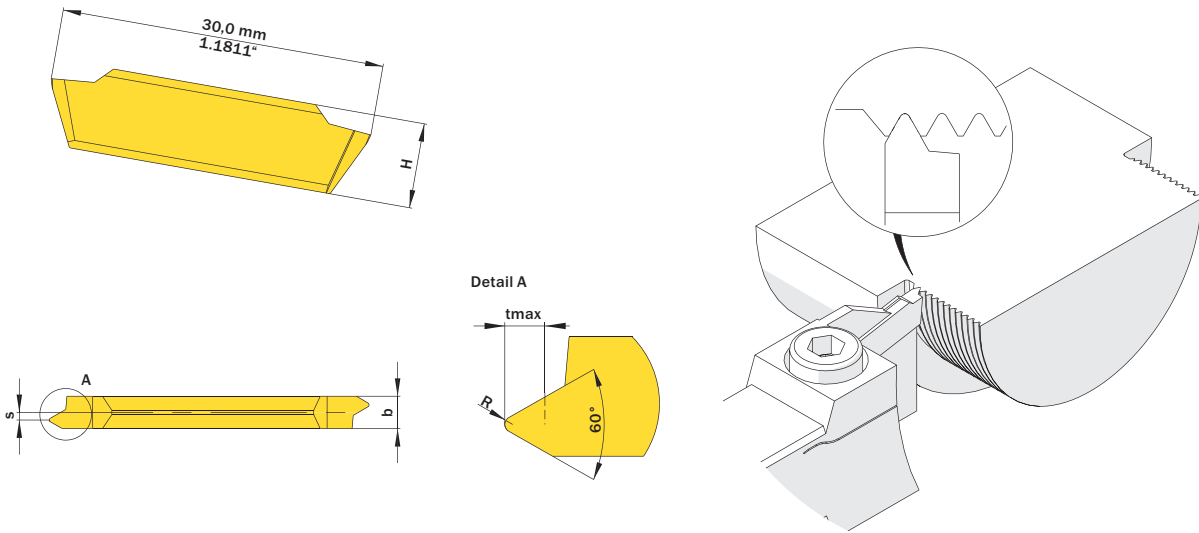


Abbildung zeigt / Drawing shows: G29.0915.01 S R

Steigung (von) Pitch (as of)	Steigung (bis) Pitch (up to)	Artikelnummer Part number	Webcode www.simtek.com/webcode	Unsere erste Wahl Our first choice					b	H	R	tmax	S	Connectcode www.simtek.com/code
				P	K	M	N	S						
1,0	1,25	G29.0610.01 S R/L	R AEYM L AGY3	X800	X600				3,3	7,9	0,14	0,81	0,8	G29.03
1,25	1,5	G29.0712.01 S R/L	R ACXW L APA9	X800	X600				3,3	7,9	0,18	0,96	0,8	G29.03
1,5	1,75	G29.0915.01 S R/L	R AENP L AC4U	X800	X600				3,3	7,9	0,22	1,1	0,7	G29.03
1,75	2,0	G29.1017.01 S R/L	R AJJD L AJ13	X800	X600				3,3	7,9	0,25	1,27	0,5	G29.03
2,0	2,5	G29.1220.01 S R/L	R AJG0 L AHS1	X800	X600				3,3	7,9	0,29	1,6	0,4	G29.03
2,5	3,0	G29.1525.01 SR/L	R AKXA L AJ3J	X800	X600				3,3	7,9	0,36	1,91	0,2	G29.03

Bestellbeispiel // Order example: **G29.0610.01 S R X800** (R = Rechte Ausführung // Right hand version, X800 = Schneidstoff // Grade)

Bitte beachten Sie die zusätzlichen Hinweise im Infobereich rechts oben.
 Please read the additional notes mentioned in the information area on the top right corner of this page.

simturn AX
simturn DX
simturn PX
simturn H2
simturn K2
simturn C4
simturn GX
simturn E3
simturn E12
simturn FX
simturn Decolletage
simturn OA
Index

Drehbearbeitung innen & außen // Internal and External Grooving and Turning
 simturn GX > Schneidwerkzeuge // Cutting Tool

Gewindedrehen, Metr. ISO, Außen, Vollprofil

Herstellung des vollständigen Gewindeprofils mit notwendiger Tiefe sowie Kopf- und Fußradien.

Threading, Metr. ISO, External, Full Profile

For a complete thread profile with correct depth, top radius and bottom radius.

Schnittwerte (Start) // Cutting parameters (start)
Anzahl Durchgänge // Number of passes 8 - 12
Empf. Zustellungsart // Recom. infeed method Flankenzustellung // Flank infeed (Seite/Page 433)
Vc Seite/Page 429

Passende Klemmhalter auf Seite // Suitable toolholders on page
295, 297, 298, 300, 301, 302, 303

SP

HM

R

Legende
Legend **315**

Scan
QR-Code
 Oder besuchen Sie // Or Visit
www.simtek.info/cp/525

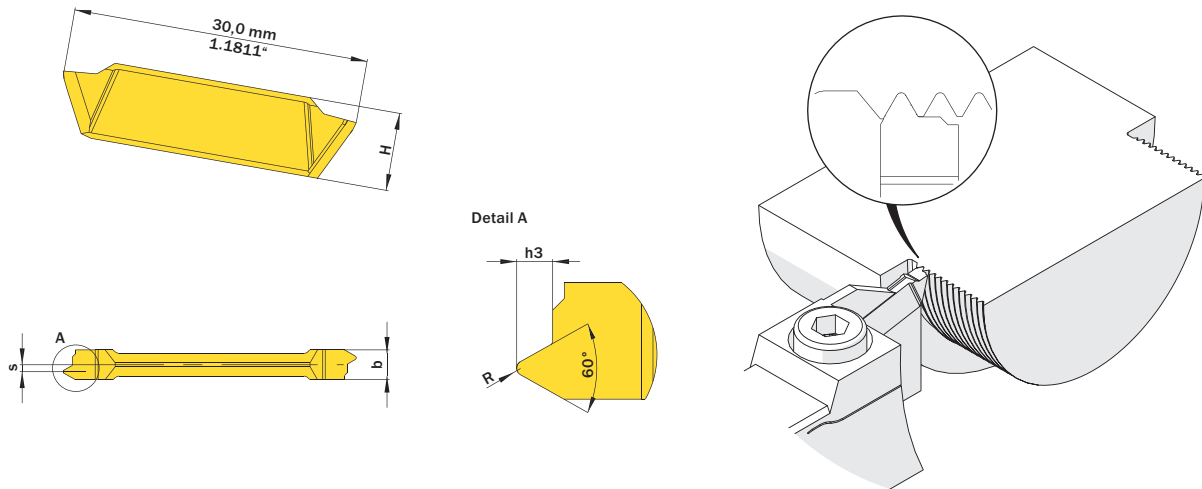


Abbildung zeigt / Drawing shows: G29.0915.02 S R

h3	Steigung (von) Pitch (as of)	Artikelnummer Part number	Webcode www.simtek.com/webcode	Unsere erste Wahl Our first choice	b	H	R	S	Connectcode www.simtek.com/code
mm	mm			P K M N S	mm	mm	mm	mm	
0,61	1,0	G29.0610.02 S R/L	R AF43 L ACF7	X800 X600	3,3	7,9	0,12	0,8	G29.03
0,77	1,25	G29.0712.02 S R/L	R AD39 L AG44	X800 X600	3,3	7,9	0,15	0,8	G29.03
0,92	1,5	G29.0915.02 S R/L	R AEHB L ADPK	X800 X600	3,3	7,9	0,2	0,7	G29.03
1,07	1,75	G29.1017.02 S R/L	R AMK1 L AEZC	X800 X600	3,3	7,9	0,25	0,5	G29.03
1,23	2,0	G29.1220.02 S R/L	R AAGP L ANDD	X800 X600	3,3	7,9	0,25	0,5	G29.03
1,53	2,5	G29.1525.02 S R/L	R AJVW L AD0G	X800 X600	3,3	7,9	0,35	0,3	G29.03

Bestellbeispiel // Order example: **G29.0915.02 S R X800** (R = Rechte Ausführung // Right hand version, X800 = Schneidstoff // Grade)

Gewindedrehen, Whitworth, Vollprofil

Herstellung des vollständigen Gewindeprofils mit notwendiger Tiefe sowie Kopf- und Fußradien. Für Innen- und Außenbearbeitung.

Threading, Whitworth, Full Profile

For a complete thread profile with correct depth, top radius and bottom radius. For internal and external application.

Schnittwerte (Start) // Cutting parameters (start)
Anzahl Durchgänge // Number of passes 8 - 12
Empf. Zustellungsart // Recom. infeed method Flankenzustellung // Flank infeed (Seite/Page 433)
Vc Seite/Page 429

Passende Klemmhalter auf Seite // Suitable toolholders on page
295, 297, 298, 300, 301, 302

SP Legende
HM Legend

315

Scan QR-Code Oder besuchen Sie // Or Visit
www.simtek.info/cp/536

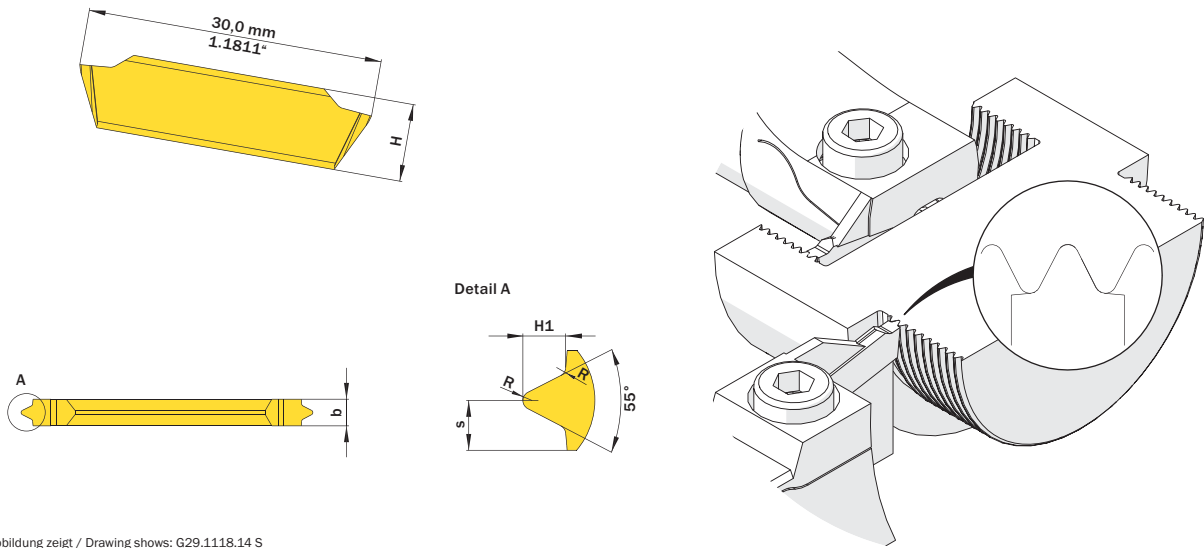


Abbildung zeigt / Drawing shows: G29.1118.14 S

H1	Steigung (vom Pitch (as of)	Gang/Zoll Threads/Inch	Artikelnummer Part number	Webcode www.simtek.com/webcode	Unsere erste Wahl Our first choice	b	H	R	S	Connectcode www.simtek.com/code
mm	mm				P K M N S	mm	mm	mm	mm	
0,581	0,907	28	G29.0509.28 S	AP3C	X800 X600	2,7	7,9	0,12	1,35	G29.02
0,86	1,34	19	G29.0813.19 S	APFH	X800 X600	2,7	7,9	0,18	1,35	G29.02
1,16	1,81	14	G29.1118.14 S	ACG8	X800 X600	2,7	7,9	0,25	1,35	G29.02
1,48	2,31	11	G29.1423.11 S	AEQ7	X800 X600	2,7	7,9	0,32	1,35	G29.02

Bestellbeispiel // Order example: **G29.1118.14 S X800** (X800 = Schneidstoff // Grade)

simturn AX
simturn DX
simturn PX
simturn H2
simturn K2
simturn C4
simturn GX
simturn E3
simturn E12
simturn FX
simturn Decolletage
simturn OA
Index

Poly-V-Riemennuten

Für Poly-V-Profile K.

Poly-V-Belt Grooves


For Poly-V-profiles K.

Schnittwerte (Start) // Cutting parameters (start)

f (außen//ext.) 0,12 mm/U	f (innen//int.) 0,09 mm/U	Vc Seite/Page 429
-------------------------------------	-------------------------------------	-----------------------------

Passende Klemmhalter auf Seite // Suitable toolholders on page

295, 297, 298, 300, 301, 302, 303



SP Legende
HM Legend **315**

Scan QR-Code Oder besuchen Sie // Or Visit
www.simtek.info/cp/1215

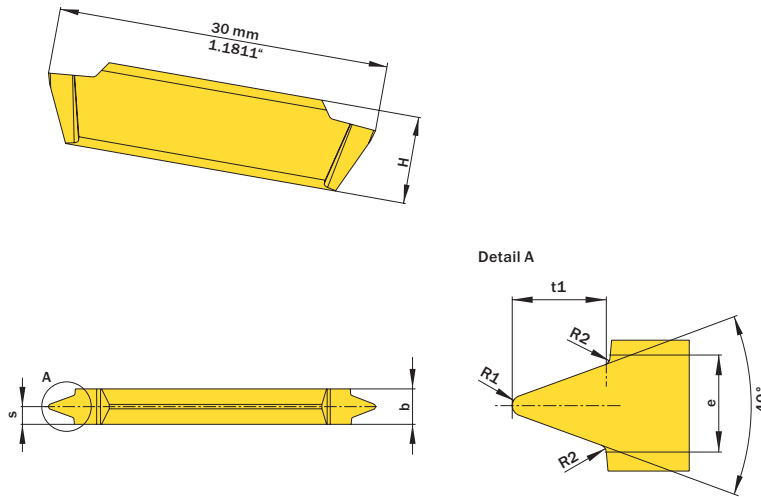


Abbildung zeigt / Drawing shows: G29.0223.00 J

e	Artikelnummer Part number	Webcode www.simtek.com/webcode	Unsere erste Wahl Our first choice	Profil Profile	b ±0,02	H	R1	R2	S	t1	Connectcode www.simtek.com/code
mm			P K M N S		mm	mm	mm	mm	mm	mm	
3,56	G29.0356.00 J	AZCH	X800 X600	K	4,0	7,9	0,35	0,25	2,25	3,69	G29.03

Bestellbeispiel // Order example: **G29.0356.00 J X800** (X800 = Schneidstoff // Grade)

Abstechen

Verfügbar in verschiedenen Breiten und Winkeln.
 Gesinterte Spanformgeometrie für kontrollierte Spanbildung.

Parting Off

Available in different widths and angles.
 Sintered geometry for improved chip control.

Schnittwerte (Start) // Cutting parameters (start)

f (außen//ext.) 0,12 mm/U	Vc Seite/Page 429
------------------------------	----------------------

Passende Klemmhalter auf Seite // Suitable toolholders on page
 295, 296, 297, 298, 299, 300, 301, 302, 303

SP

HM

R

Legende
Legend

315

Scan
QR-Code

Oder besuchen Sie // Or Visit
www.simtek.info/cp/526

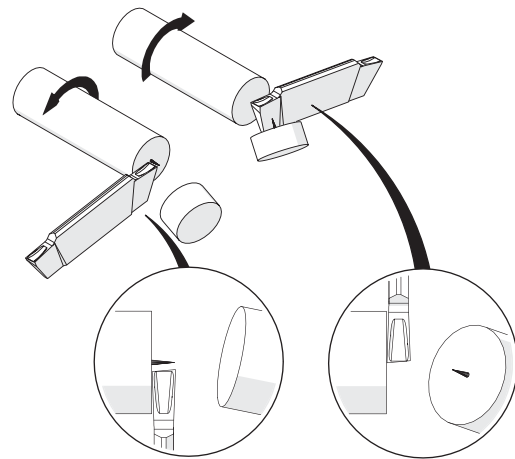
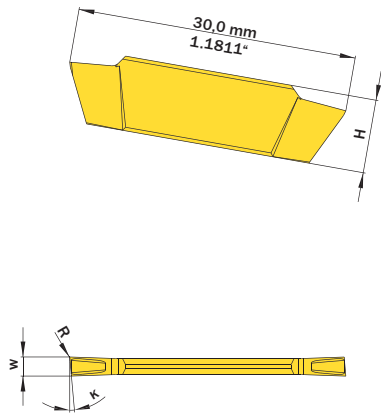


Abbildung zeigt / Drawing shows: G29.5200.32 S R

K	w ^{+0,05} mm	Artikelnummer Part number	Webcode www.simtek.com/webcode	Unsere erste Wahl Our first choice		H mm	R mm	Connectcode www.simtek.com/ccode
				P	K M N S			
▼ w = 2,0 mm								
15°	2,0	G29.1520.32 S R/L	R AMF7 L ANHX	X800	X600	7,9	0,2	G29.02
5°	2,0	G29.5200.32 S R/L	R AMW7 L AGQ9	X800	X600	7,9	0,2	G29.02
8°	2,0	G29.8200.32 S R/L	R AAKB L AFZF	X800	X600	7,9	0,2	G29.02
▼ w = 2,5 mm								
5°	2,5	G29.5250.32 S R/L	R AATN L AHAD	X800	X600	7,9	0,2	G29.02
▼ w = 3,0 mm								
15°	3,0	G29.1530.32 S R/L	R A5CF L AATT	X800	X600	7,9	0,2	G29.03 new
5°	3,0	G29.5300.32 S R/L	R AH07 L ABKE	X800	X600	7,9	0,2	G29.03
8°	3,0	G29.8300.32 S R/L	R AA90 L AM09	X800	X600	7,9	0,2	G29.03
▼ w = 4,0 mm								
5°	4,0	G29.5400.32 S R/L	R AB5F L AFQH	X800	X600	7,9	0,2	G29.03 G29.04

Bestellbeispiel // Order example: **G29.8200.32 S R X800** (R = Rechte Ausführung // Right hand version, X800 = Schneidstoff // Grade)

simturn AX
simturn DX
simturn PX
simturn H2
simturn K2
simturn C4
simturn GX
simturn E3
simturn E12
simturn FX
simturn Decolletage
simturn OA
Index

Info

Hinweisliste
Additional information

T01

Bei den simturn Teilprofil-Gewindeschneidplatten für metrische ISO-Gewinde handelt es sich um Mehrbereichswerkzeuge, d.h. dass mit einem Werkzeug unterschiedliche Steigungen gefertigt werden können.

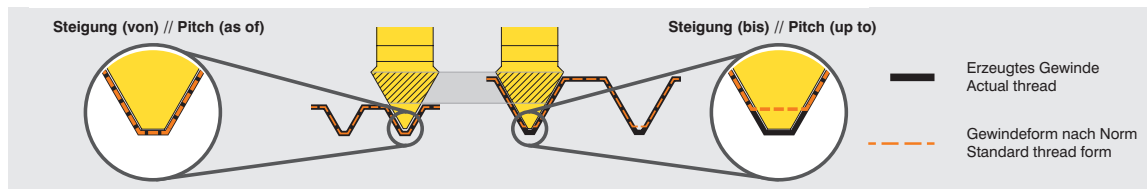
Das Schneidwerkzeug ist dabei immer auf die angegebene „Steigung (von)“ ausgelegt, wodurch ein normgerechtes Gewinde beim Fertigen dieser Steigung entsteht.

Die ebenfalls angegebene „Steigung (bis)“ kann mit diesem Werkzeug ebenfalls gefertigt werden. Es entsteht hierbei jedoch ein - gegenüber der Norm - geringfügig tieferes Gewinde. Die geringfügig höhere Gewindetiefe ist i.d.R. akzeptabel, es muss jedoch immer der Einzelfall beurteilt werden.

The simturn threading inserts with partial profile for metric ISO-threads are multi-purpose tools. This means that each insert is offering the possibility to machine different pitches.

The insert is always designed to meet the pitch given as „Pitch (as of)“: Machining this pitch will result in a standard conform thread form.


The given „Pitch (up to)“ can be machined too with this insert at the expense of standard conformity: The resulting thread will be slightly deeper than the standard. The deeper thread is usually acceptable, but the application and use needs to be evaluated.



Beispiel // Example

Info

Legende Legend

- SP**
CBN Schneidwerkzeug aus CBN // CBN insert // Outils coupants en CBN // Insetto CBN // Insetto CBN // CBN kesici uç
- SP**
HM Schneidwerkzeug aus Hartmetall // Carbide insert // Outils coupants en carbure de tungstène // Insetto in metallo duro
Insetto de carburo // Karbür kesici uç
- TW**
ST Trägerwerkzeug aus Stahl // Steel toolholder // Porte-outils en acier // Porta inserto in acciaio
Porta-herramientas de acero // Çelik tutucu
- R** Rechts wie gezeichnet // Right hand version shown, left hand version inversely // A droite comme présenté // In figura utensile destro
Modelo derecho // Sağ model
-  Innere Kühlmittelzufuhr // Through coolant // Refroidissement interne // Lubrificazione interna
Con refrigeración interna // İçten soğutmalı

simturn AX

simturn DX

simturn PX

simturn H2

simturn K2

simturn C4

simturn GX

simturn E3

simturn E12

simturn FX

simturn
Decolletage

simturn OA

Index

315

Index

simturn GX Produktverzeichnis
simturn GX Product List

Artikelnr. // Part Nr.	S/P	Artikelnr. // Part Nr.	S/P	Artikelnr. // Part Nr.	S/P	Artikelnr. // Part Nr.	S/P
G10.1.000.06 R	300	G14.0050.03 R	302	G26.2020.03 R	298	G29.1220.01 S R	309
G10.1616.02 L	300	G14.0050.04 L	302	G26.2020.04 L	298	G29.1220.02 S L	310
G10.1616.02 R	300	G14.0050.04 R	302	G26.2020.04 R	298	G29.1220.02 S R	310
G10.1616.03 L	300	G14.0050.06 L	302	G26.2525.02 L	298	G29.1423.11 S	311
G10.1616.03 R	300	G14.0050.06 R	302	G26.2525.02 R	298	G29.1520.32 S L	313
G10.1616.04 L	300	G18.0.625.02 L	295	G26.2525.03 L	298	G29.1520.32 S R	313
G10.1616.04 R	300	G18.0.625.02 R	295	G26.2525.03 R	298	G29.1525.01 SL	309
G10.2020.02 L	300	G18.0.625.03 L	295	G26.2525.04 L	298	G29.1525.01 SR	309
G10.2020.02 R	300	G18.0.625.03 R	295	G26.2525.04 R	298	G29.1525.02 S L	310
G10.2020.03 L	300	G18.0.625.04 R	296	G26.2525.06 L	298	G29.1525.02 S R	310
G10.2020.03 R	300	G18.0.750.02 L	295	G26.2525.06 R	298	G29.1530.32 S L	313
G10.2020.04 L	300	G18.0.750.02 R	295	G26.3225.03 L	298	G29.1530.32 S R	313
G10.2020.04 R	300	G18.0.750.03 L	295	G26.3225.03 R	298	G29.5200.32 S L	313
G10.2020.06 L	300	G18.0.750.03 R	295	G26.3225.04 L	298	G29.5200.32 S R	313
G10.2020.06 R	300	G18.0.750.04 L	296	G26.3225.04 R	298	G29.5250.32 S L	313
G10.2525.02 L	300	G18.0.750.04 R	296	G29.0020.10 S	308	G29.5250.32 S R	313
G10.2525.02 R	300	G18.0.750.06 L	296	G29.0030.15 S	308	G29.5300.32 S L	313
G10.2525.03 L	300	G18.0.750.06 R	296	G29.0040.20 S	308	G29.5300.32 S R	313
G10.2525.03 R	300	G18.1.000.02 L	295	G29.0050.25 S	308	G29.5400.32 S L	313
G10.2525.04 L	300	G18.1.000.02 R	295	G29.0060.30 S	308	G29.5400.32 S R	313
G10.2525.04 R	300	G18.1.000.03 L	295	G29.0200.10 S	304	G29.8200.32 S L	313
G10.2525.06 L	300	G18.1.000.03 R	295	G29.0200.32 S	306	G29.8200.32 S R	313
G10.2525.06 R	300	G18.1.000.04 L	296	G29.0250.10 S	304	G29.8300.32 S L	313
G10.3225.03 L	300	G18.1.000.04 R	296	G29.0250.32 S	306	G29.8300.32 S R	313
G10.3225.03 R	300	G18.1.000.06 L	296	G29.0300.10 S	304	G29.CB40.20 S	308
G10.3225.04 L	300	G18.1.000.06 R	296	G29.0300.20 S	305	G29.CB60.30 S	308
G10.3225.04 R	300	G18.1616.02 L	295	G29.0300.32 S	306	TOA.G10.36.02 L	301
G10.3225.06 L	300	G18.1616.02 R	295	G29.0300.34 S	306	TOA.G10.36.02 R	301
G10.3225.06 R	300	G18.1616.03 L	295	G29.0318.32 S	306	TOA.G10.36.03 L	301
G13.0025.03 L	303	G18.1616.03 R	295	G29.0318.34 S	306	TOA.G10.36.03 R	301
G13.0025.03 R	303	G18.2020.02 L	295	G29.0356.00 J	312	TOA.G10.36.04 L	301
G13.0025.04 L	303	G18.2020.02 R	295	G29.0400.10 S	304	TOA.G10.36.04 R	301
G13.0025.04 R	303	G18.2020.03 L	295	G29.0400.20 S	305	TOA.G10.36.06 L	301
G13.0032.03 L	303	G18.2020.03 R	295	G29.0400.32 S	306	TOA.G10.36.06 R	301
G13.0032.03 R	303	G18.2020.04 L	296	G29.0400.34 S	306	TOA.G18.36.02 L	297
G13.0032.04 L	303	G18.2020.04 R	296	G29.0400.52 S	307	TOA.G18.36.02 R	297
G13.0032.04 R	303	G18.2020.06 L	296	G29.0400.54 S	307	TOA.G18.36.03 L	297
G13.0032.06 L	303	G18.2020.06 R	296	G29.0500.10 S	304	TOA.G18.36.03 R	297
G13.0032.06 R	303	G18.2525.02 L	295	G29.0500.20 S	305	TOA.G18.36.04 L	297
G13.0040.03 L	303	G18.2525.02 R	295	G29.0500.34 S	306	TOA.G18.36.04 R	297
G13.0040.03 R	303	G18.2525.03 L	295	G29.0509.28 S	311	TOA.G18.36.06 L	297
G13.0040.04 L	303	G18.2525.03 R	295	G29.0600.10 S	304	TOA.G18.36.06 R	297
G13.0040.04 R	303	G18.2525.04 L	296	G29.0600.20 S	305	TOA.G25.36.04 L	299
G13.0040.06 L	303	G18.2525.04 R	296	G29.0600.34 S	306	TOA.G25.36.04 R	299
G13.0040.06 R	303	G18.2525.06 L	296	G29.0600.38 S	306		
G13.0050.03 L	303	G18.2525.06 R	296	G29.0610.01 S L	309		
G13.0050.03 R	303	G18.3225.03 L	295	G29.0610.01 S R	309		
G13.0050.04 L	303	G18.3225.03 R	295	G29.0610.02 S L	310		
G13.0050.04 R	303	G18.3225.04 L	296	G29.0610.02 S R	310		
G13.0050.06 L	303	G18.3225.04 R	296	G29.0635.32 S	306		
G13.0050.06 R	303	G18.3225.06 L	296	G29.0635.34 S	306		
G14.0032.02 L	302	G18.3225.06 R	296	G29.0712.01 S L	309		
G14.0032.02 R	302	G26.1.000.03 L	298	G29.0712.01 S R	309		
G14.0032.03 L	302	G26.1.000.03 R	298	G29.0712.02 S L	310		
G14.0032.03 R	302	G26.1.000.04 L	298	G29.0712.02 S R	310		
G14.0032.04 L	302	G26.1.000.04 R	298	G29.0813.19 S	311		
G14.0032.04 R	302	G26.1.250.03 R	298	G29.0915.01 S L	309		
G14.0032.06 L	302	G26.1.250.04 R	298	G29.0915.01 S R	309		
G14.0032.06 R	302	G26.1.250.06 R	298	G29.0915.02 S L	310		
G14.0040.03 L	302	G26.1616.02 L	298	G29.0915.02 S R	310		
G14.0040.03 R	302	G26.1616.02 R	298	G29.1017.01 S L	309		
G14.0040.04 L	302	G26.1616.03 L	298	G29.1017.01 S R	309		
G14.0040.04 R	302	G26.1616.03 R	298	G29.1017.02 S L	310		
G14.0040.06 L	302	G26.2020.02 L	298	G29.1017.02 S R	310		
G14.0040.06 R	302	G26.2020.02 R	298	G29.1118.14 S	311		
G14.0050.03 L	302	G26.2020.03 L	298	G29.1220.01 S L	309		

Das Werkzeugsystem im Überblick
The Tool System Overview

3 Schneiden... Präzision. Effizienz. Wirtschaftlichkeit.

3 cutting edges... Precision. Efficiency. Cost effectiveness.

Auswahl der Anwendungen // Choice of applications

Nutenstechen · Profildrehen · Gewinden · Abstechen · Axialstechen
Grooving · Profiling · Threading · Parting off · Face Grooving

Übersicht aller Anwendungen ab Seite 320
Overview of all applications as of page 320

Hauptanwendungen // Main applications

Nutenstechen Grooving



Wendeschneidplatten zur Herstellung von Sicherungsringnuten innen und außen nach DIN 471/472, sowie DIN 983/984. Nutnennbreiten von 0,5 mm bis 5,15 mm. Auch erhältlich mit geschliffener Spanformrille oder mit Nutaußenkantenfasung.

Indexable inserts for the machining of circlip ring grooves according to DIN 471/472 and 983/984. Nominal width of grooves from 0,5 mm up to 5,15 mm. Also available with special chip form channel or with chamfer.

Profildrehen Profiling



Einstechen und Profildrehen innen und außen. Verfügbar mit unterschiedlichen Schneidbreiten, Radien oder auch als Vollradiusvariante sowie mit doppelter Spanformrille für kontrollierte Spanbildung.

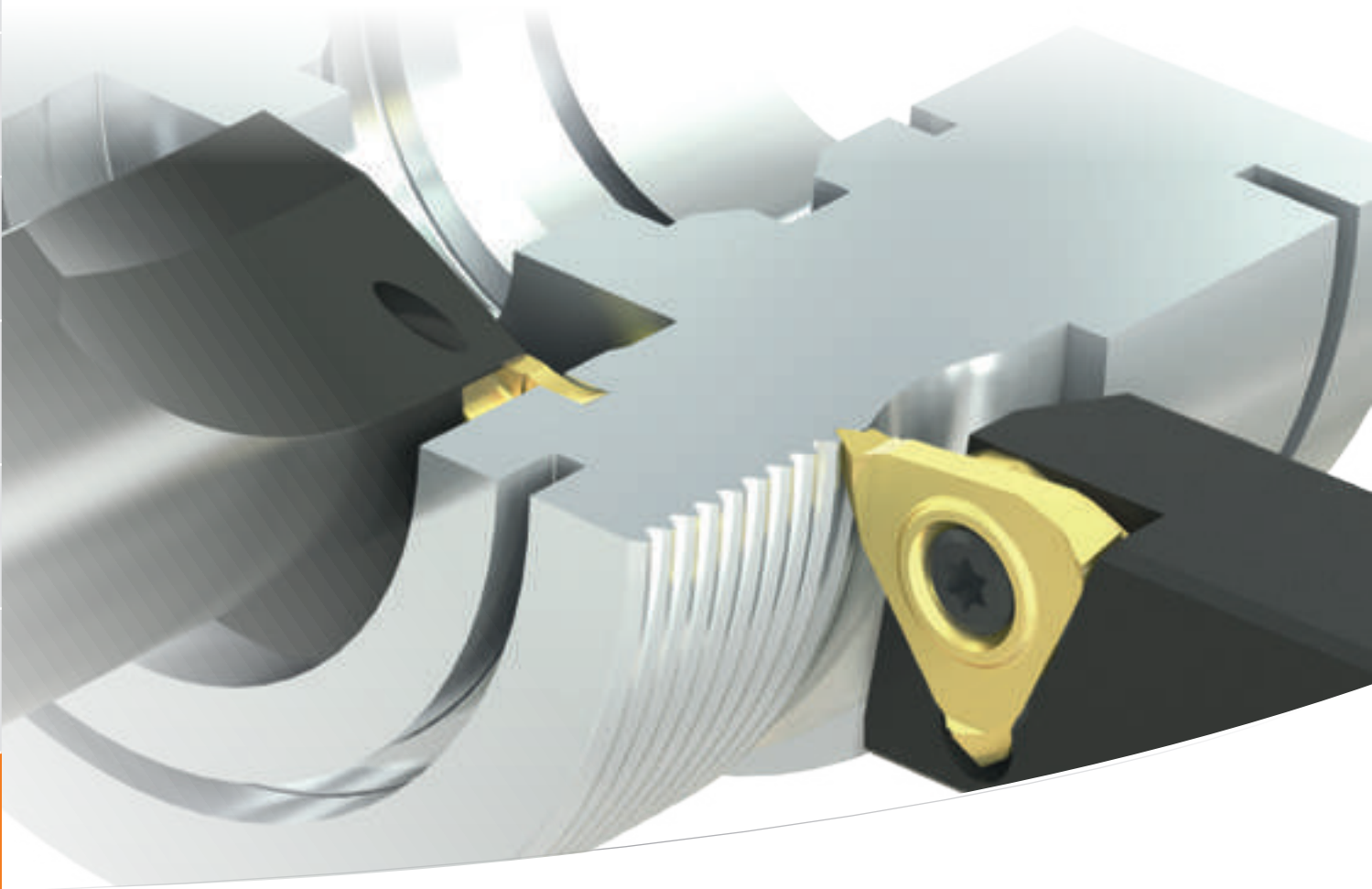
Grooving and profiling for internal and external applications. Available with various cutting edge widths, corner radii as well as with full radius and two ground chip form channels.

Gewinden Threading



Große Auswahl an Werkzeugen für die Herstellung aller gängigen Gewindearten. Sowohl für die Innens als auch für die Außenbearbeitung geeignet.

Wide range of tools for machining the most common types of threads. For internal and external applications.



Abstechen Parting off



Abstechen bis zu \varnothing 10 mm. Verfügbar mit verschiedenen Schneidbreiten, Winkeln und mit/ohne geschliffener Spanformrille.

Parting off up to \varnothing 10 mm. Available in different widths, angles and with/without ground chip form channel.

Stabilität dank seitlicher Verschraubung High stability thanks to lateral screw clamping



Das System simturn E3 bietet dank der seitlichen Verschraubung ein höchstes Maß an Stabilität. Seitlich wirkende Kräfte werden hierdurch optimal aufgenommen, wodurch eine sehr hohe Produktivität gewährleistet wird.

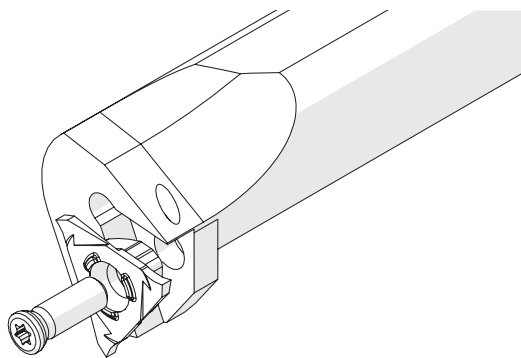
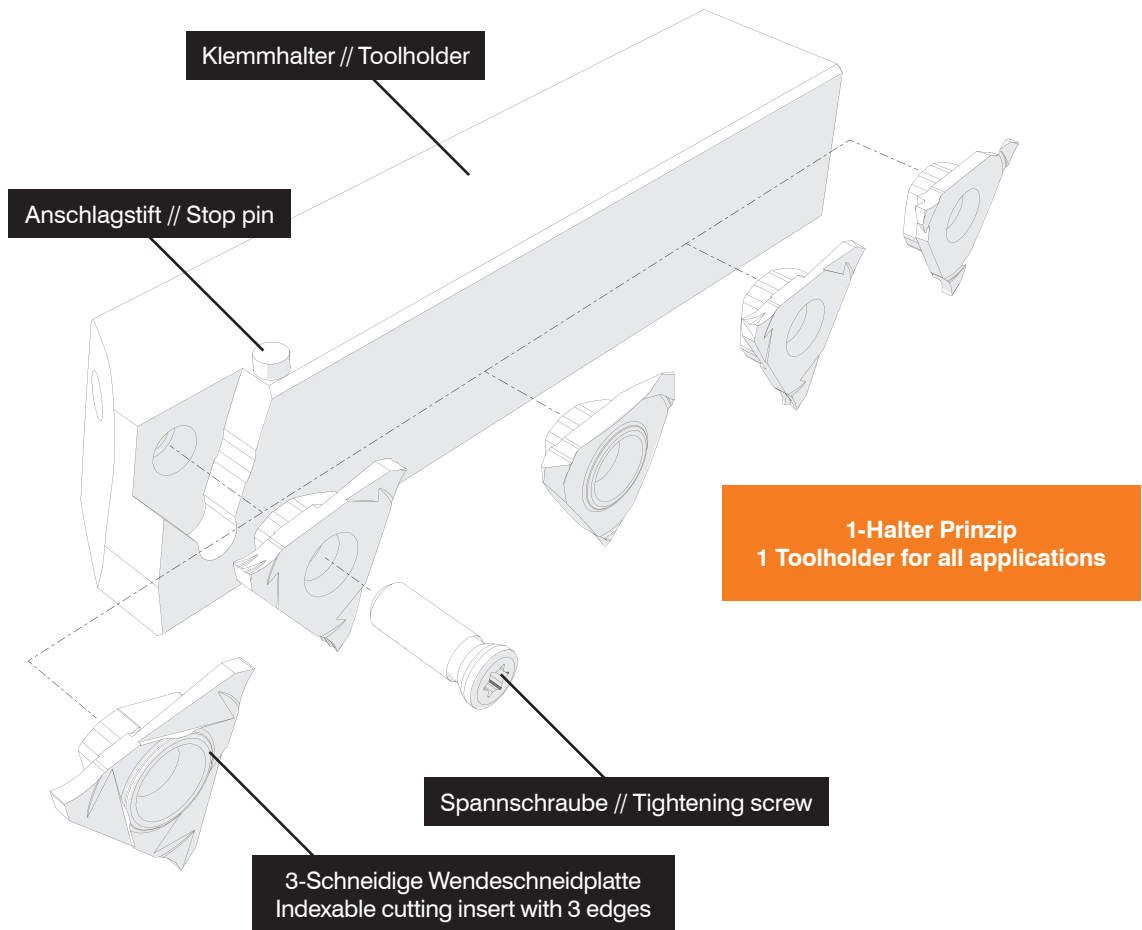
The system simturn E3 provides highest stability thanks to lateral screw clamping. This helps to absorb the longitudinal forces and provides highest efficiency.



Das System im Detail The System Details

Bitte beachten Sie die allgemeinen Gebrauchshinweise auf Seite
Please read the general instructions for use on page

433



**Verfügbar für die Innen- und Außenbearbeitung
Available for internal and external applications**

Außen // External

Maximale Stechtiefe 5,0 mm
Maximum cutting depth 5,0 mm

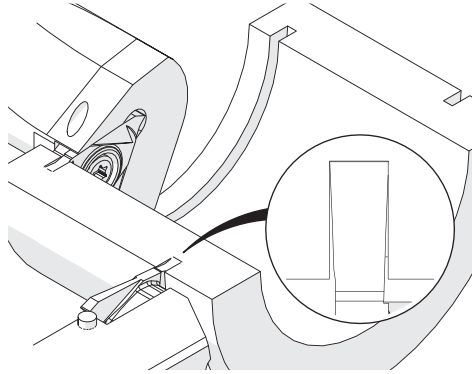
Innen // Internal

Ab Bohrungsdurchmesser 41,0 mm
As of bore diameter 41,0 mm

Standardanwendungen Standard Applications

Ab Seite
 As of page

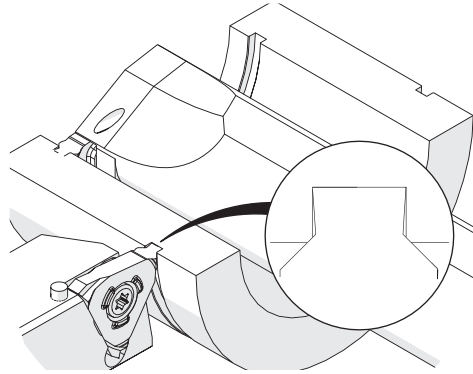
329



Stechdrehen, Sicherungsringnuten
 Grooving, Circlip Ring Grooves

Seite
 Page

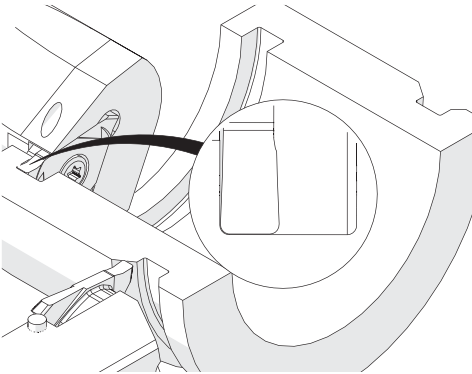
331



Stechdrehen, Sicherungsringnuten mit Fassung
 Grooving, Circlip Ring Grooves with Chamfer

Ab Seite
 As of page

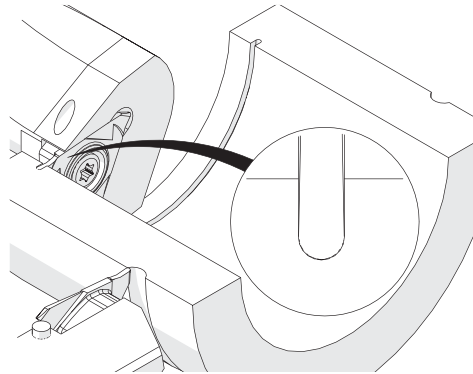
332



Einstecken und Profildrehen
 Grooving and Profiling

Seite
 Page

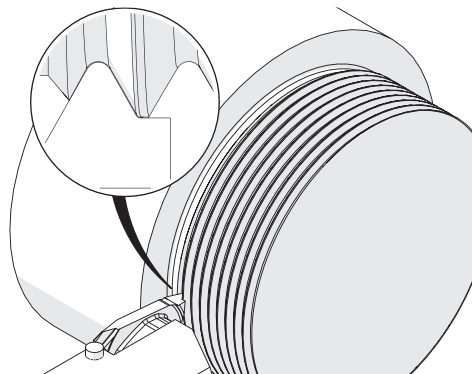
334



Einstecken und Profildrehen, Vollradius
 Grooving and Profiling, Full Radius

Seite
 Page

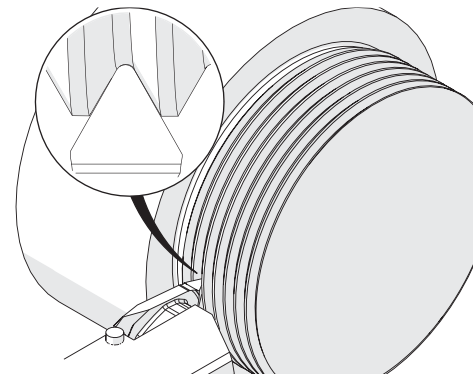
335



Gewinden: Metrisch ISO, Außen, Vollprofil
 Threading: Metric ISO, External, Full Profile

Seite
 Page

336

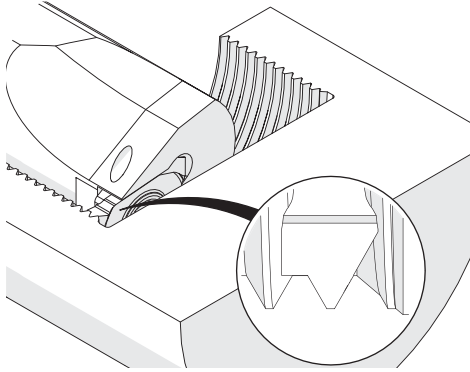


Gewinden: Metrisch ISO, Außen, Teilprofil
 Threading: Metric ISO, External, Partial Profile

Standardanwendungen Standard Applications

Seite
Page

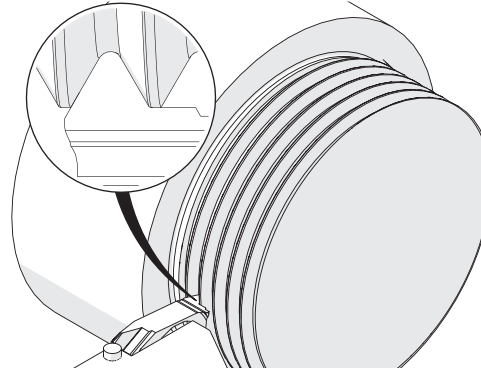
337



Gewinden: Metrisch ISO, Innen, Vollprofil
Threading: Metric ISO, Internal, Full Profile

Seite
Page

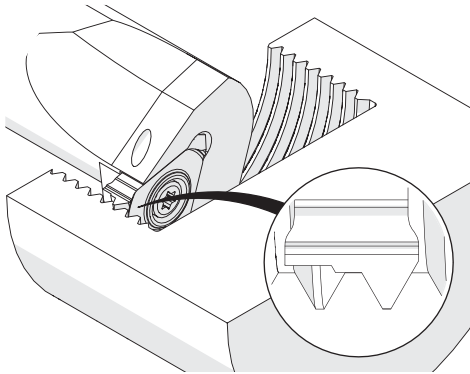
338



Gewinden: UN, Außen, Vollprofil
Threading: UN, External, Full Profile

Seite
Page

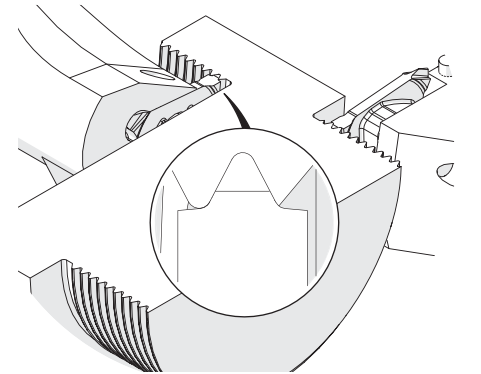
339



Gewinden: UN, Innen, Vollprofil
Threading: UN, Internal, Full Profile

Seite
Page

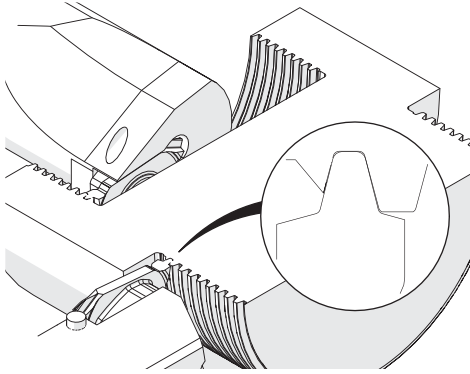
340



Gewinden: Whitworth, Vollprofil
Threading: Whitworth, Full Profile

Seite
Page

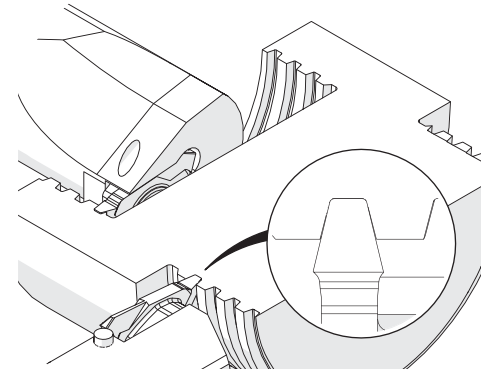
341



Gewinden: Trapezgewinde, Vollprofil
Threading: Trapezoidal Thread, Full Profile

Seite
Page

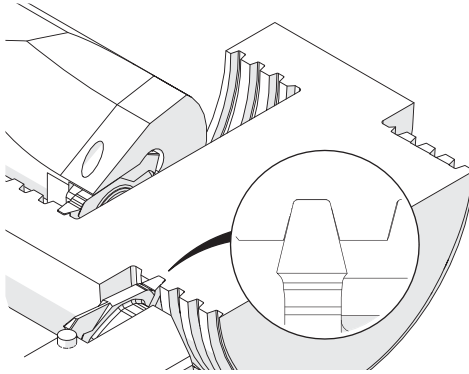
342



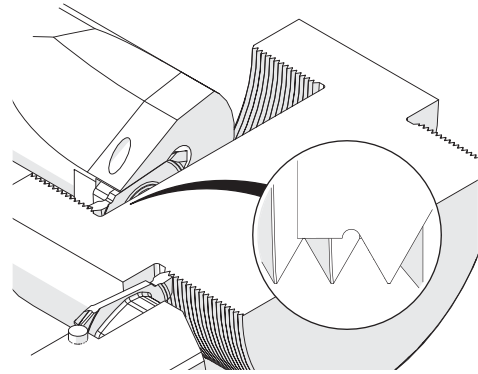
Gewinden: ACME, Teilprofil
Threading: ACME, Partial Profile

Standardanwendungen
Standard ApplicationsSeite
Page

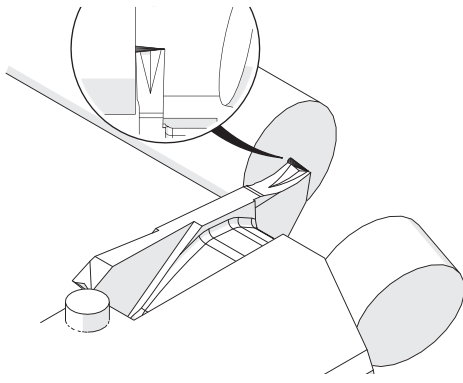
343

Gewinden: STUB ACME, Teilprofil
Threading: STUB ACME, Partial ProfileSeite
Page

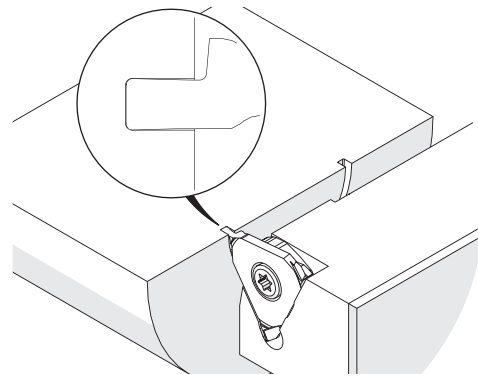
344

Gewinden: NPT, Vollprofil
Threading: NPT, Full ProfileAb Seite
As of page

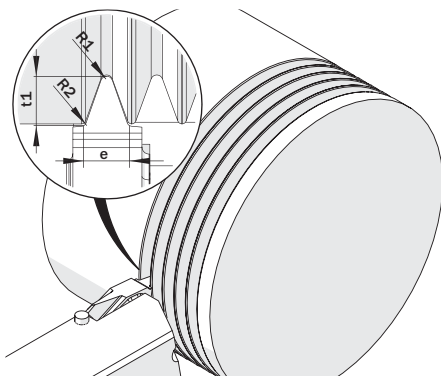
345

Abstechen
Parting offAb Seite
As of page

348

Axialstechen
Face GroovingSeite
Page

352

Poly-V-Riemennuten
Poly-V-Belt Grooves

Klemmhalter, Außenbearbeitung, Typ C

Trägerschaft für die Außenbearbeitung. Stechtiefen bis 5,0 mm.

Toolholder, for External Application, Typ C

Toolholder for external applications. Cutting depths of up to 5,0 mm.

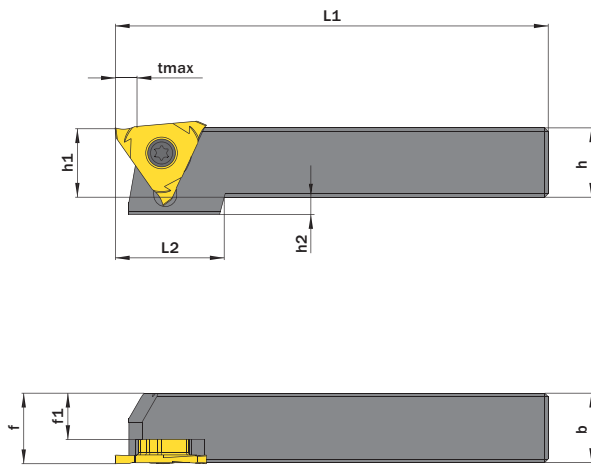
Anzugsmoment (Schraube) // Tightening torque (screw)

- “TE3 M5x11,5 T20R”: 6,0 Nm
- “TE3 M5x13 T20R”: 7,0 Nm
- “TE3 M5x15 T20R”: 6,0 Nm

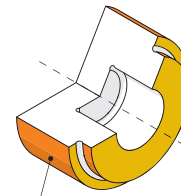


TW **ST** **R** **Legende** **354**
Legend

Scan QR-Code Oder besuchen Sie // Or Visit www.simtek.info/cp/307



tmax in Abhängigkeit vom Werkstückdurchmesser (Ød)		tmax
tmax depends on workpiece diameter (Ød)		tmax
Bis Ø100,0 mm / up to Ø3.9370"		5,0 mm / 0.1969"
Bis Ø160,0 mm / up to Ø6.2992"		4,4 mm / 0.1732"
Bis Ø250,0 mm / up to Ø9.8425"		3,7 mm / 0.1457"
Bis Ø400,0 mm / up to Ø15.7480"		3,2 mm / 0.1260"



- Hauptsächlich geeignet für diese Flächen
 Mainly designed for these surfaces
- Je nach Schneidplatte/Aufnahme ebenfalls möglich
 Also possible depending on insert/fixation type

Abbildung zeigt / Drawing shows: TE3.1616.00 R

h	b	Artikelnummer Part number	Webcode www.simtek.com/webcode	f	f1	h1 ^{s14}	h2	L1	L2	Schraube Screw	Schraubenschlüssel Screw driver	Connectcode www.simtek.com/ccode
mm	mm			mm	mm	mm	mm	mm	mm			
▼ h = 12,0 mm												
12,0	12,0	TE3.1212.00 R/L	R ACKZ L AMPP	12,3	6,7	12,0	13,0	100,0	24,0	TE3 M5x11,5 T20R	T20R	R TE3.R.5.3 L TE3.L.5.3
12,0	16,0	TE3.1216.00 R/L	R AD6G L AMTD	16,3	10,7	12,0	13,0	100,0	24,0	TE3 M5x15 T20R	T20R	R TE3.R.5.3 L TE3.L.5.3
12,0	16,0	TE3.1216.13 R/L	R AD2M L AKDQ	16,3	10,7	12,0	13,0	130,0	24,0	TE3 M5x15 T20R	T20R	R TE3.R.5.3 L TE3.L.5.3
▼ h = 12,7 mm												
12,7	12,7	TE3.0.500.00 R/L	R A2ZS L A2ZQ	13,0	7,4	12,7	12,7	100,0	24,0	TE3 M5x11,5 T20R	T20R	R TE3.R.5.3 L TE3.L.5.3 <small>inch</small>
▼ h = 15,875 mm												
15,875	15,875	TE3.0.625.00 R/L	R AEXX L AH51	16,15	10,58	15,88	9,12	100,0	22,0	TE3 M5x15 T20R	T20R	R TE3.R.5.3 L TE3.L.5.3 <small>upd inch</small>
▼ h = 16,0 mm												
16,0	16,0	TE3.1616.00 R/L	R AB6B L ADGA	16,3	10,7	16,0	9,0	100,0	22,0	TE3 M5x15 T20R	T20R	R TE3.R.5.3 L TE3.L.5.3
16,0	16,0	TE3.1616.13 R/L	R ACHT L AHFY	16,3	10,7	16,0	9,0	130,0	22,0	TE3 M5x15 T20R	T20R	R TE3.R.5.3 L TE3.L.5.3
▼ h = 19,05 mm												
19,05	19,05	TE3.0.750.00 R/L	R AH35 L AHBZ	19,35	13,75	19,05	5,95	100,0	21,0	TE3 M5x15 T20R	T20R	R TE3.R.5.3 L TE3.L.5.3 <small>inch</small>
▼ h = 20,0 mm												
20,0	20,0	TE3.2020.00 R/L	R AKQØ L AGSG	20,3	14,7	20,0	5,0	100,0	21,0	TE3 M5x15 T20R	T20R	R TE3.R.5.3 L TE3.L.5.3
20,0	20,0	TE3.2020.13 R/L	R AK6N L APMH	20,3	14,7	20,0	5,0	130,0	21,0	TE3 M5x15 T20R	T20R	R TE3.R.5.3 L TE3.L.5.3
▼ h = 25,0 mm												
25,0	25,0	TE3.2525.00 R/L	R AD35 L ANXN	25,3	19,7	25,0	-	125,0	-	TE3 M5x15 T20R	T20R	R TE3.R.5.3 L TE3.L.5.3
25,0	25,0	TE3.2525.15 R/L	R ADCH L AAP7	25,3	19,7	25,0	-	150,0	-	TE3 M5x15 T20R	T20R	R TE3.R.5.3 L TE3.L.5.3
▼ h = 25,4 mm												
25,4	25,4	TE3.1.000.00 R/L	R AUJS L AUJT	25,68	20,1	25,4	-	125,0	-	TE3 M5x15 T20R	T20R	R TE3.R.5.3 L TE3.L.5.3 <small>inch</small>
▼ h = 32,0 mm												
32,0	25,0	TE3.3225.17 R/L	R ABFD L AEDK	25,3	19,7	32,0	-	170,0	-	TE3 M5x13 T20R	T20R	R TE3.R.5.3 L TE3.L.5.3

Bestellbeispiel // Order example: **TE3.2020.00 R** (R = Rechte Ausführung // Right hand version)

simturn AX
 simturn DX
 simturn PX
 simturn H2
 simturn K2
 simturn C4
 simturn GX
 simturn E3
 simturn E12
 simturn FX
 simturn Decolletage
 simturn OA
 Index

Klemmhalter, Außenbearbeitung, Gekröpft, Typ C

Trägerschaft für die Außenbearbeitung, 90° gekröpft
 Ausführung. Stechtiefen bis 5,0 mm.

Toolholder, For External Application, Cranked, Typ C

Toolholder for external applications. 90° cranked style. Cutting depths of up to 5,0 mm.

Anzugsmoment (Schraube) // Tightening torque (screw)

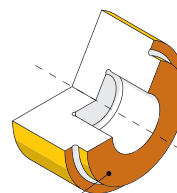
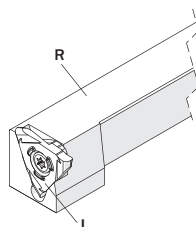
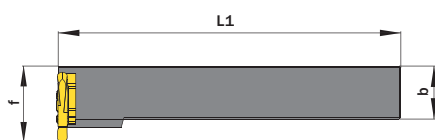
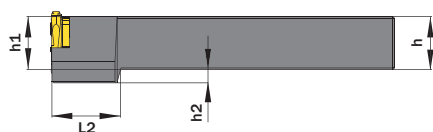
6,0 Nm



Legende **354**



Oder besuchen Sie // Or Visit www.simtek.info/cp/331



Bitte beachten: Rechter Halter wird mit linker Platte bestückt und umgekehrt.
 Please use right hand toolholder with left hand insert and vice versa.

- Hauptsächlich geeignet für diese Flächen
 Mainly designed for these surfaces
- Je nach Aufnahmetyp ebenfalls möglich
 Also possible depending on fixation type

Abbildung zeigt / Drawing shows: TE3.1616.90 R

h	b	Artikelnummer Part number	Webcode www.simtek.com/webcode		f	h1 ^{is14}	h2	L1	L2	Schraube Screw	Schraubenschlüssel Screw driver	Connectcode www.simtek.com/code		
mm	mm		R	L	mm	mm	mm	mm	mm			R	L	
15,875	15,875	TE3.0.625.90 R/L	R A5TD	L A5TF	23,0	16,0	9,0	125,0	15,0	TE3 M5x15 T20R	T20R	R TE3.L.5.3	L TE3.R.5.3	new inch
19,05	19,05	TE3.0.750.90 R/L	R A5TK	L A5TH	27,0	20,0	5,0	125,0	15,0	TE3 M5x15 T20R	T20R	R TE3.L.5.3	L TE3.R.5.3	new inch
25,4	25,4	TE3.1.000.90 R/L	R A5TN	L A5TQ	32,0	25,4	-	125,0	-	TE3 M5x15 T20R	T20R	R TE3.L.5.3	L TE3.R.5.3	new inch
16,0	16,0	TE3.1616.90 R/L	R ASD7	L ASD8	23,0	16,0	9,0	125,0	15,0	TE3 M5x15 T20R	T20R	R TE3.L.5.3	L TE3.R.5.3	
20,0	20,0	TE3.2020.90 R/L	R APXG	L AABH	27,0	20,0	5,0	125,0	15,0	TE3 M5x15 T20R	T20R	R TE3.L.5.3	L TE3.R.5.3	
25,0	25,0	TE3.2525.90 R/L	R AC7J	L AGSY	32,0	25,0	-	150,0	-	TE3 M5x15 T20R	T20R	R TE3.L.5.3	L TE3.R.5.3	

Bestellbeispiel // Order example: **TE3.2525.90 R** (R = Rechte Ausführung // Right hand version)

Klemmhalter, Innenbearbeitung, Typ A

Trägerschaft für die Innenbearbeitung. Geeignet für kleinere Bohrungen, Stechtiefen bis 5,0 mm und Schneidenbreiten bis 5,3 mm.

Toolholder, For Internal Applications, Type A

Toolholder for internal applications. For use in smaller bore diameters. Depth of cut up to 5,0 mm with maximum width of 5,3 mm.

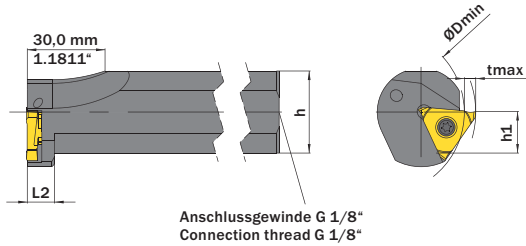
Anzugsmoment (Schraube) // Tightening torque (screw)

6,0 Nm



Legende Legend **354**

Scan QR-Code Oder besuchen Sie // Or Visit www.simtek.info/cp/318



Anschlussgewinde G 1/8" Connection thread G 1/8"

TE3.0025.A.00 R/L, TE3.0032.A.00 R/L		TE3.0040.A.00 R/L	
Bohrungsdurchmesser (ØDmin)		Bohrungsdurchmesser (ØDmin)	
Bore diameter (ØDmin)	tmax	Bore diameter (ØDmin)	tmax
Ø41,0 mm / Ø1.6142"	0,0 mm / 0.0000"	Ø48,0 mm / Ø1.8898"	0,0 mm / 0.0000"
Ø43,0 mm / Ø1.6929"	1,0 mm / 0.0394"	Ø49,0 mm / Ø1.9291"	1,0 mm / 0.0394"
Ø44,0 mm / Ø1.7323"	2,0 mm / 0.0787"	Ø50,0 mm / Ø1.9685"	2,0 mm / 0.0787"
Ø46,0 mm / Ø1.8110"	3,0 mm / 0.1181"	Ø52,0 mm / Ø2.0472"	3,0 mm / 0.1181"
Ø50,0 mm / Ø1.9685"	4,0 mm / 0.1575"	Ø54,0 mm / Ø2.1260"	4,0 mm / 0.1575"
Ø90,0 mm / Ø3.5433"	5,0 mm / 0.1969"	Ø120,0 mm / Ø4.7244"	5,0 mm / 0.1969"

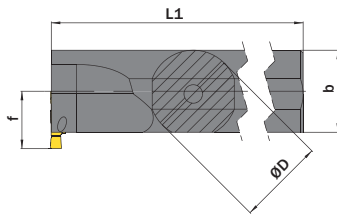
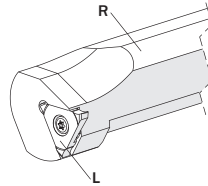
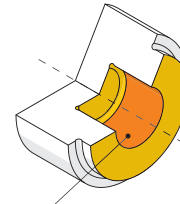


Abbildung zeigt / Drawing shows: TE3.0032.A.00 R



Bitte beachten: Rechter Halter wird mit linker Platte bestückt und umgekehrt. Please use right hand toolholder with left hand insert and vice versa.



■ Hauptsächlich geeignet für diese Flächen
 Mainly designed for these surfaces
 ■ Je nach Schneidplatte ebenfalls möglich
 Also possible depending on insert type

ØD #6 mm	Artikelnummer Part number	Webcode www.simtek.com/webcode	b	f	h	h1	L1	L2	Schraube Screw	Schraubenschlüssel Screw driver	Connectcode www.simtek.com/code	
											R	L
25,0	TE3.0025.A.00 R/L	R ACA5 L AH48	25,0	18,5	23,0	11,5	170,0	10,0	TE3 M5x15 T20R	T20R	R TE3.L.5.3	L TE3.R.5.3
32,0	TE3.0032.A.00 R/L	R ANDC L AG06	30,0	20,0	30,0	15,0	200,0	10,0	TE3 M5x15 T20R	T20R	R TE3.L.5.3	L TE3.R.5.3
40,0	TE3.0040.A.00 R/L	R AJSM L AJFN	38,0	24,0	38,0	19,0	250,0	10,0	TE3 M5x15 T20R	T20R	R TE3.L.5.3	L TE3.R.5.3

Bestellbeispiel // Order example: **TE3.0025.A.00 R** (R = Rechte Ausführung // Right hand version)

- Geeignet für Schneidenbreiten bis 5,3 mm
- Designed for cutting widths of up to 5,3 mm

simturn AX
 simturn DX
 simturn PX
 simturn H2
 simturn K2
 simturn C4
 simturn GX
 simturn E3
 simturn E12
 simturn FX
 simturn Decoletage
 simturn OA
 Index

Klemmhalter, Innenbearbeitung, Typ C

Trägerschaft für die Innenbearbeitung.
 Stechtiefen bis 3,0 mm ohne Einschränkung der Schneidenbreite.

Toolholder, For Internal Applications, Type C

Toolholder for internal applications.
 Depth of cut up to 3,0 mm without limitation toward cutting width.

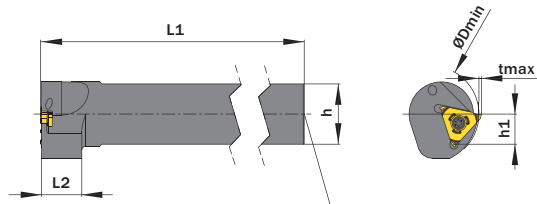
Anzugsmoment (Schraube) // Tightening torque (screw)

6,0 Nm



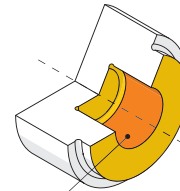
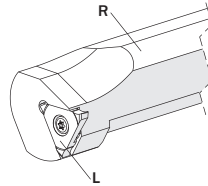
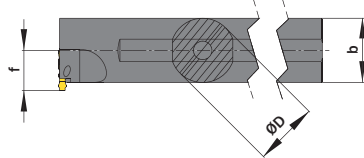
Legende
 Legend **354**

Scan QR-Code Oder besuchen Sie // Or Visit www.simtek.info/cp/484



Anschlussgewinde G 1/8"
 Connection thread G 1/8"

TE3.0025.C.00 R/L, TE3.0032.C.00 R/L		TE3.0040.C.00 R/L	
Bohrungsdurchmesser (ØDmin)		Bohrungsdurchmesser (ØDmin)	
Bore diameter (ØDmin)	tmax	Bore diameter (ØDmin)	tmax
Ø48,0 mm / Ø1.8898"	0,0 mm / 0.0000"	Ø50,0 mm / Ø1.9685"	0,0 mm / 0.0000"
Ø50,0 mm / Ø1.9685"	1,0 mm / 0.0394"	Ø52,0 mm / Ø2.0472"	1,0 mm / 0.0394"
Ø53,0 mm / Ø2.0866"	2,0 mm / 0.0787"	Ø70,0 mm / Ø2.7559"	2,0 mm / 0.0787"
Ø110,0 mm / Ø4.3307"	3,0 mm / 0.1181"	Ø150,0 mm / Ø5.9055"	3,0 mm / 0.1181"



Bitte beachten: Rechter Halter wird mit linker Platte bestückt und umgekehrt.
 Please use right hand toolholder with left hand insert and vice versa.

☑️ Hauptsächlich geeignet für diese Flächen
 Mainly designed for these surfaces
 ☑️ Je nach Schneidplatte ebenfalls möglich
 Also possible depending on insert type

Abbildung zeigt / Drawing shows: TE3.0032.C.00 R

ØD ^{±0.06}	Artikelnummer Part number	Webcode www.simtek.com/webcode		b	f	h	h1 ^{js14}	L1	L2	Schraube Screw	Schraubenschlüssel Screw driver	Connectcode www.simtek.com/code	
25,0	TE3.0025.C.00 R/L	R ASDC	L ASBT	25,0	16,5	23,0	11,5	150,0	20,0	TE3 M5x15 T20R	T20R	R TE3.L.5.3	L TE3.R.5.3
25,4	TE3.1.000.C.00 R/L	R APT1	L AE59	25,4	16,5	25,4	12,7	150,0	20,0	TE3 M5x15 T20R	T20R	R TE3.L.5.3	L TE3.R.5.3 inch
32,0	TE3.0032.C.00 R/L	R ASDE	L ASDD	32,0	20,0	30,0	15,0	200,0	20,0	TE3 M5x15 T20R	T20R	R TE3.L.5.3	L TE3.R.5.3
40,0	TE3.0040.C.00 R/L	R ASDG	L ASDF	40,0	24,0	38,0	19,0	250,0	20,0	TE3 M5x15 T20R	T20R	R TE3.L.5.3	L TE3.R.5.3
31,75	TE3.1.250.C.00 R/L	R A5TV	L A5TT	31,8	20,0	29,8	14,9	200,0	20,0	TE3 M5x15 T20R	T20R	R TE3.L.5.3	L TE3.R.5.3 new
38,1	TE3.1.500.C.00 R/L	R A5TZ	L A5TX	40,0	24,0	36,1	18,0	250,0	20,0	TE3 M5x15 T20R	T20R	R TE3.L.5.3	L TE3.R.5.3 new

Bestellbeispiel // Order example: **TE3.0025.C.00 R** (R = Rechte Ausführung // Right hand version)

Kassette für Modulares Werkzeugsystem TOA

Geeignet für SIMTEK Grundhalter mit Polygonschaft nach ISO 26623.

Cassette for Modular Tool System TOA

For use on SIMTEK base toolholder with polygon shank according to ISO 26623.

Anzugsmoment (Schraube) // Tightening torque (screw)

6,0 Nm



TW
ST

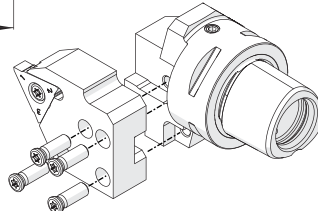
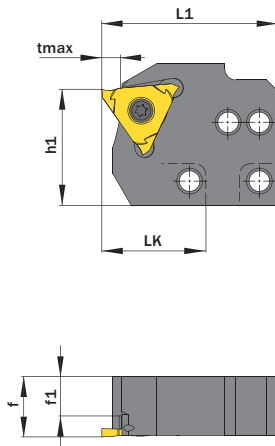
R

Legende
Legend **354**

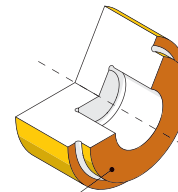


Scan
QR-Code

Oder besuchen Sie // Or Visit
www.simtek.info/cp/1184



Schrauben für Kassettenbefestigung
Screw for cassette mounting
T M5x15 T20R



- Hauptsächlich geeignet für diese Flächen
Mainly designed for these surfaces
- Je nach Aufnahmetyp ebenfalls möglich
Also possible depending on fixation type

Abbildung zeigt / Drawing shows: TOA.TE3.51.C.29.05 R

Artikelnummer Part number	Webcode www.simtek.com/webcode		b	f	f1	h1	LK	L1	tmax	Schraube Screw	Schraubenschlüssel Screw driver	Connectcode www.simtek.com/cocode		Adaptcode Adaptcode
												R	L	
TOA.TE3.51.C.19.05 R/L	R AZBG	L AZBF	16,0	16,4	10,8	31,6	19,0	37,9	5,0	TE3 M5x15 T20R	T20R	R TE3.R.5.3	L TE3.L.5.3	TOA R/L
TOA.TE3.51.C.29.05 R/L	R AZBE	L AZBD	16,0	16,4	10,8	31,6	29,0	47,9	5,0	TE3 M5x15 T20R	T20R	R TE3.R.5.3	L TE3.L.5.3	TOA R/L

Bestellbeispiel // Order example: **TOA.TE3.51.C.29.05 R** (R = Rechte Ausführung // Right hand version)

simturn AX
simturn DX
simturn PX
simturn H2
simturn K2
simturn C4
simturn GX
simturn E3
simturn E12
simturn FX
simturn Decoletage
simturn OA
Index

Höhenverstellbare Kassette, für Rückseitenbearbeitungen

Kassette für höhenverstellbare Rückseitenbearbeitung auf Grundhaltern-Typ „TOG“ der Marke precium.

Height-Adjustable Cassette for Back Operations

Cassette for height-adjustable back operations tools. Compatible to TOG-system by precium.

Anzugsmoment (Schraube) // Tightening torque (screw)

6,0 Nm



Legende
 Legend **354**



Scan
 QR-Code

Oder besuchen Sie // Or Visit
www.simtek.info/cp/975

Mehr Informationen unter www.precium.de
 More information on www.precium.de

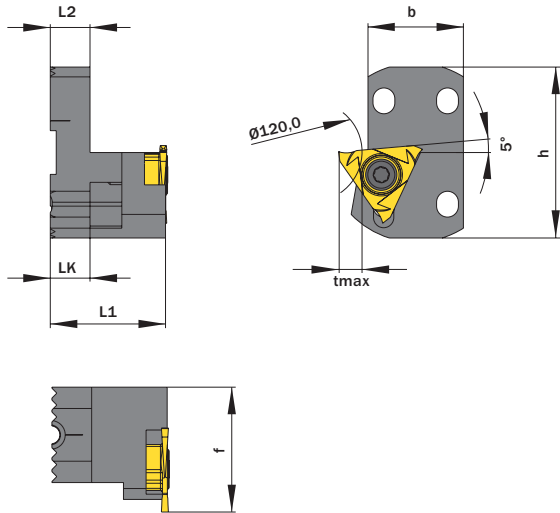


Abbildung ähnlich // Illustration only

Abbildung zeigt / Drawing shows: TOG.K.TE3.A1 R

Mit Kühlmittelzufuhr With through coolant supply	Artikelnummer Part number	Webcode www.simtek.com/webcode		b	h	f	L1	L2	LK	tmax	Schraube Screw	Schraubenschlüssel Screw driver	Connectcode www.simtek.com/code					
															mm	mm	mm	mm
Nein / No	TOG.K.TE3.A1 R/L	R	AT4D	L	AT4C	24,0	43,0	31,4	29,0	10,0	10,0	4,5	TE3 M5x15 T20R	T20R	R	TE3.R.5.3	L	TE3.L.5.3
Ja / Yes	TOG.K.TE3.B1 R/L	R	AT4H	L	AT4G	24,0	43,0	31,4	46,0	27,0	10,0	4,5	TE3 M5x15 T20R	T20R	R	TE3.R.5.3	L	TE3.L.5.3

Bestellbeispiel // Order example: **TOG.K.TE3.A1 R** (R = Rechte Ausführung // Right hand version)

Stechdrehen, Sicherungsringnuten

Sicherungsringnuten vgl. DIN 471/472 sowie DIN 983/984.

Grooving, circlip ring grooves

Circlip ring grooves comp. to DIN 471/472 and DIN 983/984.

Schnittwerte (Start) // Cutting parameters (start)		
f (außen/ext.) 0,04 mm/U	f (innen/int.) 0,03 mm/U	Vc Seite/Page 429

Passende Klemmhalter auf Seite // Suitable toolholders on page
323, 324, 325, 326, 327, 328

SP
HM
R

Legende
Legend **354**

Scan
QR-Code

Oder besuchen Sie // Or Visit
www.simtek.info/cp/308

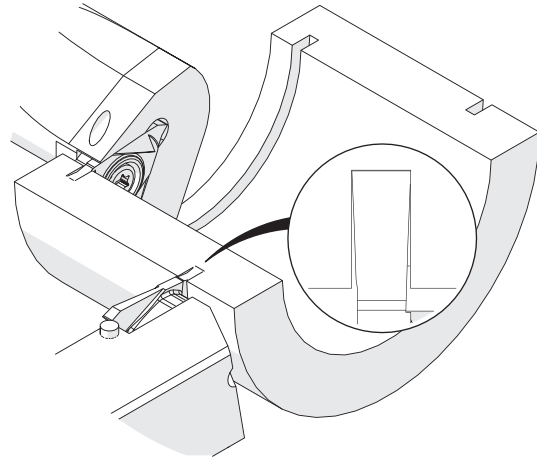
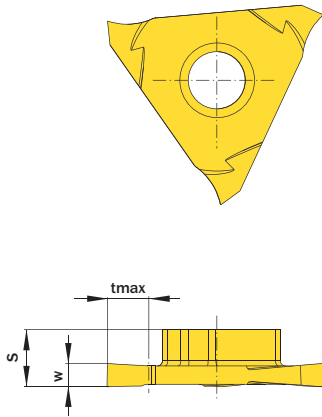


Abbildung zeigt / Drawing shows: TE3.0215.00 GR

Nennbreite Nominal width of groove	w ^{+0,03} mm	Artikelnummer Part number	Webcode www.simtek.com/webcode	Unsere erste Wahl Our first choice				S mm	tmax mm	Connectcode www.simtek.com/code
				P	K	M	S			
0,5	0,53	TE3.0050.00 G R/L	R AH0J L AF84	X808	X408			5,45	1,43	R TE3.R.5.3 L TE3.L.5.3
0,6	0,63	TE3.0060.00 G R/L	R ADA6 L ADCK	X808	X408			5,45	1,68	R TE3.R.5.3 L TE3.L.5.3
0,7	0,73	TE3.0070.00 G R/L	R AJ4V L AAUT	X808	X408			5,45	1,93	R TE3.R.5.3 L TE3.L.5.3
0,8	0,83	TE3.0080.00 G R/L	R APHD L ADJM	X808	X408			5,45	2,18	R TE3.R.5.3 L TE3.L.5.3
0,9	0,93	TE3.0090.00 G R/L	R AGBW L ANNB	X808	X408			5,45	2,43	R TE3.R.5.3 L TE3.L.5.3
1,0	1,03	TE3.0100.00 G R/L	R AFBT L AKEK	X808	X408			5,45	2,68	R TE3.R.5.3 L TE3.L.5.3
1,1	1,2	TE3.0110.00 G R/L	R AP21 L AJJB	X800	X600			5,6	5,0	R TE3.R.5.3 L TE3.L.5.3
1,1	1,2	TE3.0110.31 G R/L	R AQBUL AQBS	X800	X600			5,6	3,1	R TE3.R.5.3 L TE3.L.5.3
1,17	1,31	TE3.0117.00 GR	A4XX	X800	X600			5,6	5,0	TE3.R.5.3 <small>NEW inch</small>
1,3	1,4	TE3.0130.00 G R/L	R AHV0 L AD91	X800	X600			5,6	5,0	R TE3.R.5.3 L TE3.L.5.3
1,6	1,7	TE3.0160.00 G R/L	R AD0B L AH1Z	X800	X600			5,6	5,0	R TE3.R.5.3 L TE3.L.5.3
1,85	1,95	TE3.0185.00 G R/L	R APGF L AMV5	X800	X600			5,6	5,0	R TE3.R.5.3 L TE3.L.5.3
2,15	2,25	TE3.0215.00 G R/L	R AB92 L AKUE	X800	X600			5,6	5,0	R TE3.R.5.3 L TE3.L.5.3
2,65	2,75	TE3.0265.00 G R/L	R AKW4 L ABJZ	X800	X600			5,6	5,0	R TE3.R.5.3 L TE3.L.5.3
3,15	3,25	TE3.0315.00 G R/L	R AJQN L AHE6	X800	X600			5,6	5,0	R TE3.R.5.3 L TE3.L.5.3
4,15	4,25	TE3.0415.00 G R/L	R AFAK L AE23	X800	X600			5,6	5,0	R TE3.R.5.3 L TE3.L.5.3
5,15	5,25	TE3.0515.00 G R/L	R AE14 L AF57	X800	X600			5,6	5,0	R TE3.R.5.3 L TE3.L.5.3

Bestellbeispiel // Order example: **TE3.0130.00 G R X800** (R = Rechte Ausführung // Right hand version, X800 = Schneidstoff // Grade)



TE3. w, 1/100 mm, 4 Stellen/Digits . R, 1/100 mm, 3 Stellen/Digits Toleranz // Tolerance R/L
 Beispielartikelnummer // Example Part number: **TE3.0156.015 XN R** oder/ or **TE3.0156.015 XN L**

simturn AX
simturn DX
simturn PX
simturn H2
simturn K2
simturn C4
simturn GX
simturn E3
simturn E12
simturn FX
simturn Decolletage
simturn OA
Index

Drehbearbeitung innen & außen // Internal and External Grooving and Turning
 simturn E3 > Schneidwerkzeug // Cutting Tool

simturnE3
 SIMTEK small part machining type E3

Stechdrehen, Sicherungsringnuten, mit geschliffener Spanformrille

Sicherungsringnuten vgl. DIN 471/472 sowie DIN 983/984, mit Spanformrille.

Grooving, Circlip Ring Grooves, with ground chip form channel

Circlip ring grooves comp. to DIN 471/472 and DIN 983/984, with chip form channel.

Schnittwerte (Start) // Cutting parameters (start)

f (außen//ext.) 0,04 mm/U	f (innen//int.) 0,03 mm/U	Vc Seite/Page 429
-------------------------------------	-------------------------------------	-----------------------------

Passende Klemmhalter auf Seite // Suitable toolholders on page
323, 324, 325, 326, 327, 328

SP

HM

R

Legende
Legend **354**

Scan
QR-Code

Oder besuchen Sie // Or Visit
www.simtek.info/cp/884

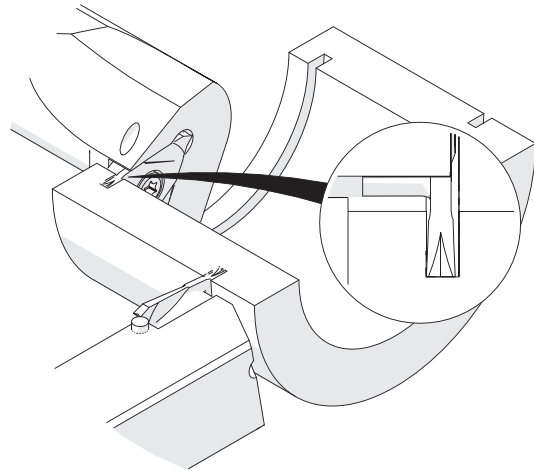
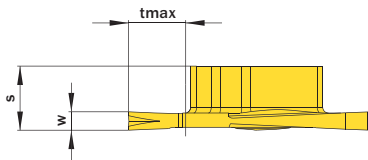
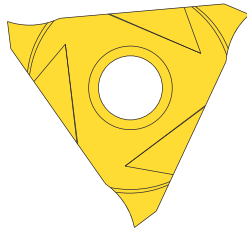


Abbildung zeigt / Drawing shows: TE3.0160.00 GT R

Nennbreite Nominal width of groove	w ^{+0,03} mm	Mit Spanformrille With chip form channel	Artikelnummer Part number	Webcode www.simtek.com/webcode		Unsere erste Wahl Our first choice	S mm	tmax mm	Connectcode www.simtek.com/code	
				P	K				M	N
1,1	1,2	Ja / Yes	TE3.0110.00 GT R/L	R AT0M	L AT0N	X800 X600	5,6	5,0	R	TE3.R.5.3 L TE3.L.5.3
1,3	1,4	Ja / Yes	TE3.0130.00 GT R/L	R AT0P	L AT0Q	X800 X600	5,6	5,0	R	TE3.R.5.3 L TE3.L.5.3
1,6	1,7	Ja / Yes	TE3.0160.00 GT R/L	R AT0S	L AT0T	X800 X600	5,6	5,0	R	TE3.R.5.3 L TE3.L.5.3
1,85	1,95	Ja / Yes	TE3.0185.00 GT R/L	R AT0U	L AT0V	X800 X600	5,6	5,0	R	TE3.R.5.3 L TE3.L.5.3
2,15	2,25	Ja / Yes	TE3.0215.00 GT R/L	R AT0W	L AT0X	X800 X600	5,6	5,0	R	TE3.R.5.3 L TE3.L.5.3

Bestellbeispiel // Order example: **TE3.0185.00 GT R X800** (R = Rechte Ausführung // Right hand version, X800 = Schneidstoff // Grade)

Stechdrehen, Sicherungsringnuten mit Fassung


Sicherungsringnuten vgl. DIN 471/472 sowie DIN 983/984, mit Nutaußenkantenfasung.

Grooving, Circlip Ring Grooves with Chamfer

Circlip ring grooves comp. to DIN 471/472 and DIN 983/984, with chamfer.

Schnittwerte (Start) // Cutting parameters (start)		
f (außen//ext.) 0,04 mm/U	f (innen//int.) 0,03 mm/U	Vc Seite/Page 429

Passende Klemmhalter auf Seite // Suitable toolholders on page
323, 324, 325, 326, 327, 328

	 SP  HM  R	Legende Legend	354
		Scan QR-Code	Oder besuchen Sie // Or Visit www.simtek.info/cp/332

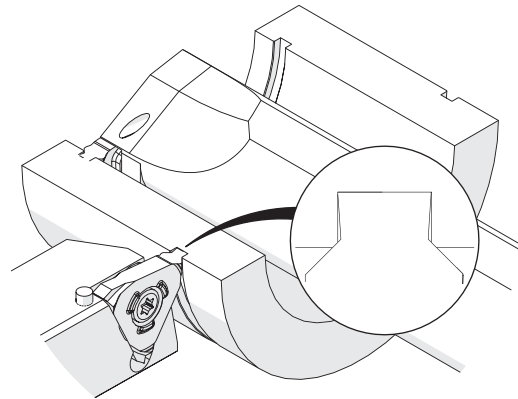
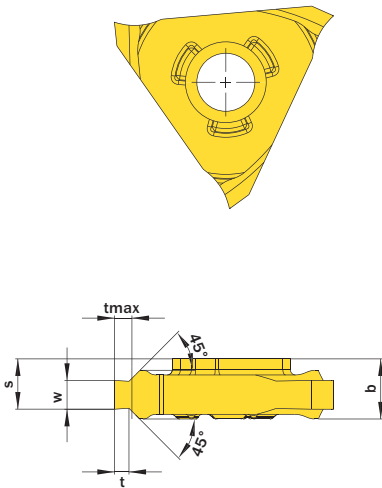


Abbildung zeigt / Drawing shows: TE3.2616.00 F R

Nutnennbreite Nominal width of groove	w ^{+0,03}	Artikelnummer Part number	Webcode www.simtek.com/webcode	Unsere erste Wahl Our first choice	b	s	t	tmax	Connectcode www.simtek.com/code	
										P
▼ Nutnennbreite // Nominal width of groove = 1,1 mm										
1,1	1,2	TE3.1105.00 F R/L	R AFC9 L AN28	X800 X600	5,8	5,37	0,36	0,4	R TE3.R.5.3 L TE3.L.5.3	
▼ Nutnennbreite // Nominal width of groove = 1,3 mm										
1,3	1,4	TE3.1306.00 F R/L	R AEQZ L AMVQ	X800 X600	5,8	5,47	0,45	0,55	R TE3.R.5.3 L TE3.L.5.3	
▼ Nutnennbreite // Nominal width of groove = 1,6 mm										
1,6	1,7	TE3.1607.00 F R/L	R AACQ L APPJ	X800 X600	5,8	5,49	0,6	0,7	R TE3.R.5.3 L TE3.L.5.3	
1,6	1,7	TE3.1608.00 F R/L	R AK00 L ABUB	X800 X600	5,8	5,49	0,75	0,85	R TE3.R.5.3 L TE3.L.5.3	
1,6	1,7	TE3.1609.00 F R/L	R AJ0M L ANCC	X800 X600	5,8	5,49	0,85	1,0	R TE3.R.5.3 L TE3.L.5.3	
▼ Nutnennbreite // Nominal width of groove = 1,85 mm										
1,85	1,95	TE3.1810.00 F R/L	R ACD6 L ANG2	X800 X600	5,8	5,47	0,85	1,0	R TE3.R.5.3 L TE3.L.5.3	
1,85	1,95	TE3.1812.00 F R/L	R ABE7 L AG5M	X800 X600	5,8	5,47	1,1	1,25	R TE3.R.5.3 L TE3.L.5.3	
▼ Nutnennbreite // Nominal width of groove = 2,15 mm										
2,15	2,25	TE3.2115.00 F R/L	R AB8G L AGPQ	X800 X600	5,8	5,17	1,35	1,5	R TE3.R.5.3 L TE3.L.5.3	
▼ Nutnennbreite // Nominal width of groove = 2,65 mm										
2,65	2,75	TE3.2616.00 F R/L	R ADY6 L ANB3	X800 X600	5,8	5,37	1,35	1,5	R TE3.R.5.3 L TE3.L.5.3	
2,65	2,75	TE3.2617.00 F R/L	R ACFT L APV8	X800 X600	5,8	5,37	1,6	1,75	R TE3.R.5.3 L TE3.L.5.3	
▼ Nutnennbreite // Nominal width of groove = 3,15 mm										
3,15	3,25	TE3.3118.00 F R/L	R AC3K L AKVF	X800 X600	5,8	5,12	1,6	1,75	R TE3.R.5.3 L TE3.L.5.3	
▼ Nutnennbreite // Nominal width of groove = 4,15 mm										
4,15	4,25	TE3.4120.00 F R/L	R AAGD L AAGN	X800 X600	5,8	5,12	1,85	2,0	R TE3.R.5.3 L TE3.L.5.3	
4,15	4,25	TE3.4125.00 F R/L	R AFPP L APTT	X800 X600	5,8	5,12	2,35	2,5	R TE3.R.5.3 L TE3.L.5.3	
▼ Nutnennbreite // Nominal width of groove = 5,15 mm										
5,15	5,25	TE3.5130.00 F R/L	R ADWB L AF7M	X800 X600	6,6	5,82	2,85	3,0	R TE3.R.5.3 L TE3.L.5.3	

Bestellbeispiel // Order example: **TE3.2115.00 F R X800** (R = Rechte Ausführung // Right hand version, X800 = Schneidstoff // Grade)

simturn AX
simturn DX
simturn PX
simturn H2
simturn K2
simturn C4
simturn GX
simturn E3
simturn E12
simturn FX
simturn Decolletage
simturn OA
Index

Einstecken und Profildrehen

CNC-Konturdrehen.

Grooving and Profiling

CNC profiling.

Schnittwerte (Start) // Cutting parameters (start)

f (außen/ext.) 0,04 mm/U	f (innen/int.) 0,03 mm/U	Vc Seite/Page 429
-----------------------------	-----------------------------	----------------------

Passende Klemmhalter auf Seite // Suitable toolholders on page
323, 324, 325, 326, 327, 328

SP
CBN

SP
HM

R

Legende
Legend

354

Scan
QR-Code

Oder besuchen Sie // Or Visit
www.simtek.info/cp/309

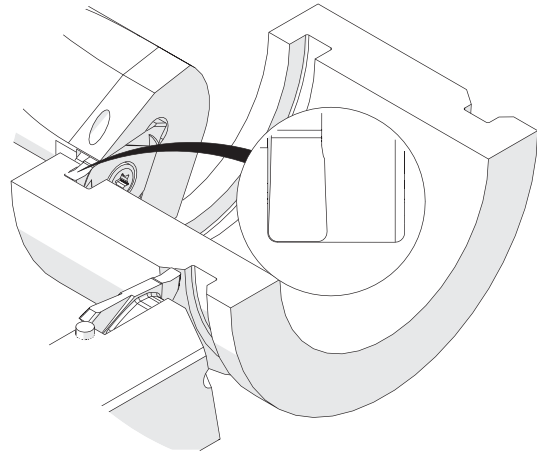
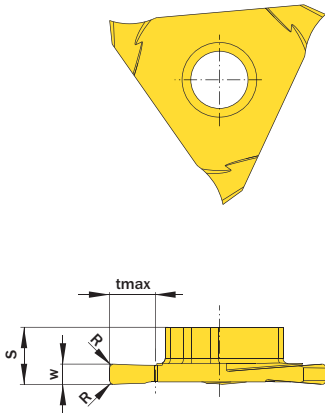


Abbildung zeigt / Drawing shows: TE3.0200.04 NR

w ±0,02 mm	R mm	Artikelnummer Part number	Webcode www.simtek.com/webcode	Unsere erste Wahl Our first choice	S mm	tmax mm	Connectcode www.simtek.com/code	
▼ R = 0,05 mm								
1,0	0,05	TE3.0100.005 N R/L	R A1T4 L A41Z	X808 X408	5,45	2,5	R TE3.R.5.3 L TE3.L.5.3 new	
▼ R = 0,2 mm								
1,0	0,2	TE3.0100.02 N R/L	R AUKW L AUKX	X808 X408	5,45	2,5	R TE3.R.5.3 L TE3.L.5.3	
1,5	0,2	TE3.0150.02 N R/L	R AGUC L AJCØ	X800 X600	5,6	5,0	R TE3.R.5.3 L TE3.L.5.3	
2,0	0,2	TE3.0200.02 N R/L	R AAFU L AMG1	X800 X600	5,6	5,0	R TE3.R.5.3 L TE3.L.5.3	
2,388	0,2	TE3.0238.02 N R	A55T	X800 X600	5,6	5,0	TE3.R.5.3 new	
2,5	0,2	TE3.0250.02 N R/L	R AQHV L AQHW	X800 X600	5,55	5,0	R TE3.R.5.3 L TE3.L.5.3	
3,0	0,2	TE3.0300.02 N R/L	R AEY1 L AJYY	X800 X600	5,55	5,0	R TE3.R.5.3 L TE3.L.5.3	
3,175	0,2	TE3.0318.02 N R	A55V	X800 X600	5,6	5,0	TE3.R.5.3 new	
4,0	0,2	TE3.0400.02 N R/L	R ABXC L AB96	X800 X600	5,6	5,0	R TE3.R.5.3 L TE3.L.5.3	
4,75	0,2	TE3.0475.02 N R	A55X	X800 X600	5,6	5,0	TE3.R.5.3 new	
▼ R = 0,4 mm								
2,0	0,4	TE3.0200.04 N R/L	R AQMV L AQMW	X800 X600	5,6	5,0	R TE3.R.5.3 L TE3.L.5.3	
2,5	0,4	TE3.0250.04 N R/L	R AG8Y L AGBH	X800 X600	5,6	5,0	R TE3.R.5.3 L TE3.L.5.3	
3,0	0,4	TE3.0300.04 N R/L	R AQHY L AQHX	X800 X600	5,6	5,0	R TE3.R.5.3 L TE3.L.5.3	
4,0	0,4	TE3.0400.04 N R/L	R ASE2 L ASE1	X800 X600	5,6	5,0	R TE3.R.5.3 L TE3.L.5.3	
▼ R = 0,6 mm								
3,0	0,6	TE3.0300.06 N R/L	R AT61 L AT60	X800 X600	5,6	5,0	R TE3.R.5.3 L TE3.L.5.3	
▼ R = 0,8 mm								
3,0	0,8	TE3.0300.08 N R/L	R AT7T L AT7S	X800 X600	5,6	5,0	R TE3.R.5.3 L TE3.L.5.3	

Bestellbeispiel // Order example: **TE3.0200.02 N R X800** (R = Rechte Ausführung // Right hand version, X800 = Schneidstoff // Grade)



TE3. w, 1/100 mm, 4 Stellen/Digits . R, 1/100 mm, 3 Stellen/Digits Toleranz // Tolerance R/L

Beispielartikelnummer // Example Part number: **TE3.0156.015 XN R** oder/ or **TE3.0156.015 XN L**

Einstecken und Profildrehen, Doppelspanformrille

Stechen und Längsdrehen. CNC-Konturdrehen.
 Mit geschliffener doppelter Spanformrille.

Grooving and Profiling, Two Ground Chip Form Channels

Grooving and turning. CNC profiling.
 With two ground chip form channels.

Schnittwerte (Start) // Cutting parameters (start)		
f (außen//ext.) 0,04 mm/U	f (innen//int.) 0,03 mm/U	Vc Seite/Page 429

Passende Klemmhalter auf Seite // Suitable toolholders on page
323, 324, 325, 326, 327, 328

SP

HM

R

Legende
Legend **354**

Scan
QR-Code

Oder besuchen Sie // Or Visit
www.simtek.info/cp/951

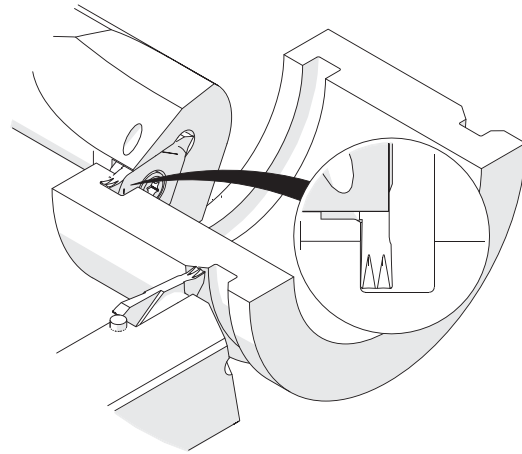
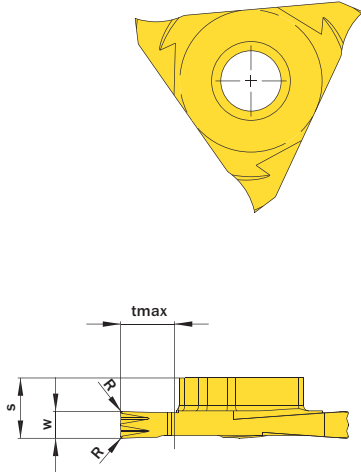


Abbildung zeigt / Drawing shows: TE3.0250.02 NW R

w^{-0,05}	R	Artikelnummer Part number	Webcode www.simtek.com/webcode	Unsere erste Wahl Our first choice	S	tmax	Connectcode www.simtek.com/ccode
mm	mm			P K M N S	mm	mm	
2,5	0,2	TE3.0250.02 NW R/L	R AUQT L AZ43	X800 X600	5,6	5,0	R TE3.R.5.3 L TE3.L.5.3

Bestellbeispiel // Order example: **TE3.0250.02 NW R X800** (R = Rechte Ausführung // Right hand version, X800 = Schneidstoff // Grade)

simturn AX
simturn DX
simturn PX
simturn H2
simturn K2
simturn C4
simturn GX
simturn E3
simturn E12
simturn FX
simturn Decolletage
simturn OA
Index

Einstecken und Profildrehen, Vollradius

Vollradiusnuten, CNC-Konturdrehen.

Grooving and Profiling, Full Radius

Full radius, CNC profiling.

Schnittwerte (Start) // Cutting parameters (start)

f (außen//ext.) 0,04 mm/U	f (innen//int.) 0,03 mm/U	Vc Seite/Page 429
-------------------------------------	-------------------------------------	-----------------------------

Passende Klemmhalter auf Seite // Suitable toolholders on page
323, 324, 325, 326, 327, 328



Legende
 Legend **354**



Oder besuchen Sie // Or Visit
www.simtek.info/cp/310

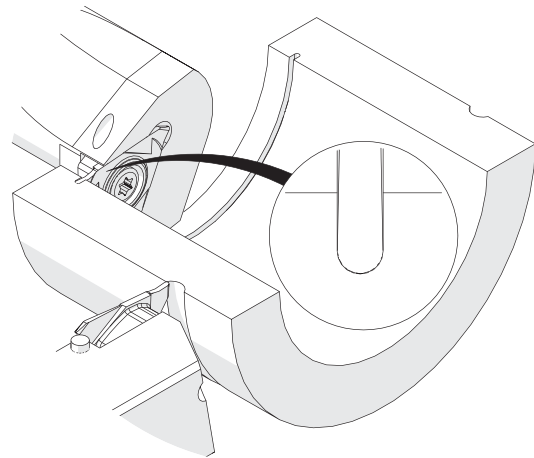
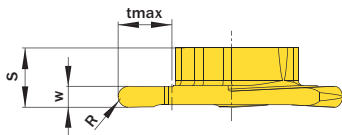
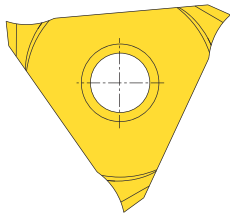


Abbildung zeigt / Drawing shows: TE3.0200.10 VR

w ^{+0,04} mm	R mm	Artikelnummer Part number	Webcode www.simtek.com/webcode	Unsere erste Wahl Our first choice				S mm	tmax mm	Connectcode www.simtek.com/code	
				P	K	M	N			S	R
1,0	0,5	TE3.0100.05 VR/L	R AA7W L ANCX	X800	X600			5,45	2,5	R TE3.R.5.3	L TE3.L.5.3
1,2	0,6	TE3.0120.06 VR/L	R AHPN L AK8F	X800	X600			5,6	3,0	R TE3.R.5.3	L TE3.L.5.3
1,5	0,75	TE3.0150.07 VR/L	R AT74 L AT73	X800	X600			5,6	5,0	R TE3.R.5.3	L TE3.L.5.3
1,575	0,79	TE3.0157.079 VR	A449	X800	X600			5,6	5,0	TE3.R.5.3 <small>new item</small>	
1,6	0,8	TE3.0160.08 VR/L	R AB6N L AJAC	X800	X600			5,6	5,0	R TE3.R.5.3	L TE3.L.5.3
1,8	0,9	TE3.0180.09 VR/L	R AFP3 L AKC9	X800	X600			5,6	5,0	R TE3.R.5.3	L TE3.L.5.3
2,0	1,0	TE3.0200.10 VR/L	R APHH L ACYV	X800	X600			5,6	5,0	R TE3.R.5.3	L TE3.L.5.3
2,2	1,1	TE3.0220.11 VR/L	R AJ0Q L ANTV	X800	X600			5,6	5,0	R TE3.R.5.3	L TE3.L.5.3
2,5	1,25	TE3.0250.12 VR/L	R AAFE L AMTK	X800	X600			5,6	5,0	R TE3.R.5.3	L TE3.L.5.3
2,8	1,4	TE3.0280.14 VR/L	R ANA5 L AMFA	X800	X600			5,6	5,0	R TE3.R.5.3	L TE3.L.5.3
3,0	1,5	TE3.0300.15 VR/L	R AB7P L AD5J	X800	X600			5,6	5,0	R TE3.R.5.3	L TE3.L.5.3
3,6	1,8	TE3.0360.18 VR/L	R AT00 L AT01	X800	X600			5,6	5,0	R TE3.R.5.3	L TE3.L.5.3
4,0	2,0	TE3.0400.20 VR/L	R ANK8 L APDZ	X800	X600			5,6	5,0	R TE3.R.5.3	L TE3.L.5.3

Bestellbeispiel // Order example: **TE3.0160.08 V R X800** (R = Rechte Ausführung // Right hand version, X800 = Schneidstoff // Grade)

Gewindedrehen, Metr. ISO, Außen, Vollprofil

Herstellung des vollständigen Gewindeprofils mit notwendiger Tiefe sowie Kopf- und Fußradien.

Threading, Metr. ISO, external, full profile

For a complete thread profile with correct depth, top radius and bottom radius.

Schnittwerte (Start) // Cutting parameters (start)

Anzahl Durchgänge // Number of passes
8 - 12

Empf. Zustellungsart // Recom. infeed method
Flankenzustellung // Flank infeed (Seite/Page 433)

Vc Seite/Page **429**

Passende Klemmhalter auf Seite // Suitable toolholders on page
323, 324, 325, 326, 327, 328

SP

HM

R

○

Legende
Legend **354**

Scan QR-Code Oder besuchen Sie // Or Visit
www.simtek.info/cp/313

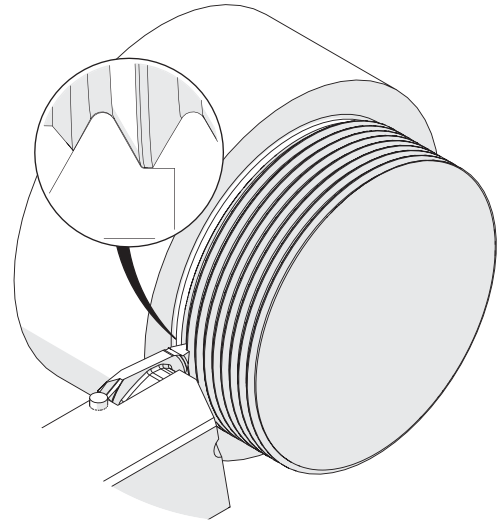
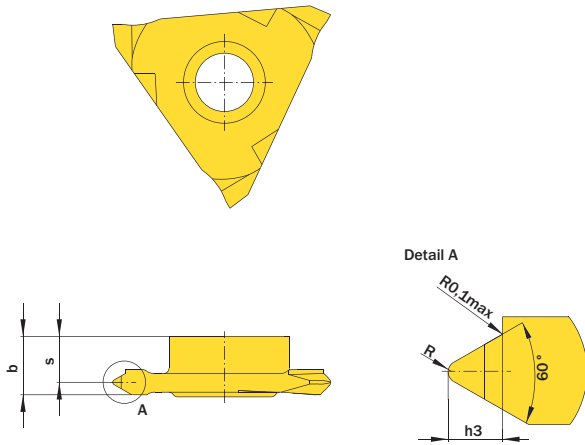


Abbildung zeigt / Drawing shows: TE3.MT20.02 EM R

Steigung (von) Pitch (as of)	Artikelnummer Part number	Webcode www.simtek.com/webcode	Unsere erste Wahl Our first choice				b	h3	R	S	Connectcode www.simtek.com/code	
			P	K	M	S					R	L
0,5	TE3.MT05.02 EM R/L	R AV91 L AV92	X800	X600		5,6	0,31	0,07	4,8	R	TE3.R.5.3 L TE3.L.5.3	
0,75	TE3.MT07.02 EM R/L	R AQVT L ATWK	X800	X600		5,6	0,46	0,11	4,8	R	TE3.R.5.3 L TE3.L.5.3	
0,8	TE3.MT08.02 EM R/L	R ASFS L ATWM	X800	X600		5,6	0,49	0,12	4,7	R	TE3.R.5.3 L TE3.L.5.3	
1,0	TE3.MT10.02 EM R/L	R AFHK L ANBA	X800	X600		5,6	0,61	0,14	4,6	R	TE3.R.5.3 L TE3.L.5.3	
1,25	TE3.MT12.02 EM R/L	R ABFQ L AEP4	X800	X600		5,6	0,77	0,18	4,5	R	TE3.R.5.3 L TE3.L.5.3	
1,5	TE3.MT15.02 EM R/L	R AKFX L ABVJ	X800	X600		5,6	0,92	0,22	4,4	R	TE3.R.5.3 L TE3.L.5.3	
1,75	TE3.MT17.02 EM R/L	R AHWM L AJFB	X800	X600		5,6	1,07	0,25	4,1	R	TE3.R.5.3 L TE3.L.5.3	
2,0	TE3.MT20.02 EM R/L	R ABX6 L AHXC	X800	X600		5,6	1,23	0,29	4,1	R	TE3.R.5.3 L TE3.L.5.3	
2,5	TE3.MT25.02 EM R/L	R ADA1 L AAXP	X800	X600		5,6	1,53	0,36	3,9	R	TE3.R.5.3 L TE3.L.5.3	
3,0	TE3.MT30.02 EM R/L	R AMUN L ANFC	X800	X600		5,6	1,84	0,43	3,8	R	TE3.R.5.3 L TE3.L.5.3	
3,5	TE3.MT35.02 EM R/L	R AP36 L AMGF	X800	X600		5,6	2,15	0,51	3,5	R	TE3.R.5.3 L TE3.L.5.3	
4,0	TE3.MT40.02 EM R/L	R AAAW L AAFC	X800	X600		5,6	2,45	0,58	3,6	R	TE3.R.5.3 L TE3.L.5.3	
5,0	TE3.MT50.02 EM R/L	R AB6F L AMYX	X800	X600		5,95	3,07	0,72	3,55	R	TE3.R.5.3 L TE3.L.5.3	
6,0	TE3.MT60.02 EM R/L	R AGXM L AMSW	X800	X600		6,6	3,68	0,87	3,5	R	TE3.R.5.3 L TE3.L.5.3	

Bestellbeispiel // Order example: **TE3.MT15.02 EM R X800** (R = Rechte Ausführung // Right hand version, X800 = Schneidstoff // Grade)

simturn AX
simturn DX
simturn PX
simturn H2
simturn K2
simturn C4
simturn GX
simturn E3
simturn E12
simturn FX
simturn Decolletage
simturn OA
Index

Gewindedrehen, Metr. ISO, Außen, Teilprofil

Mehrbereichswerkzeuge für verschiedene Steigungen.

Threading, Metr. ISO, External, Partial Profile

Multi-purpose tools, usable for different pitches.

Schnittwerte (Start) // Cutting parameters (start)
Anzahl Durchgänge // Number of passes 8 - 12
Empf. Zustellungsart // Recom. infeed method Flankenzustellung // Flank infeed (Seite/Page 433)
Vc Seite/Page 429
Passende Klemmhalter auf Seite // Suitable toolholders on page 323, 324, 325, 326, 327, 328
Bitte Hinweise im Anhang beachten // Please read add. notes T01 (Seite/Page 353)

SP
HM

R

Legende
Legend

354

Scan QR-Code

Oder besuchen Sie // Or Visit www.simtek.info/cp/312

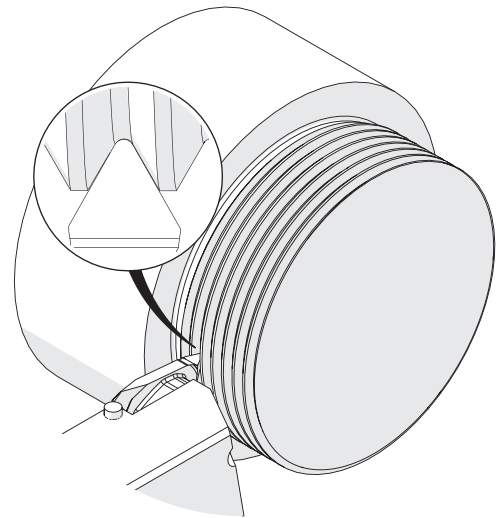
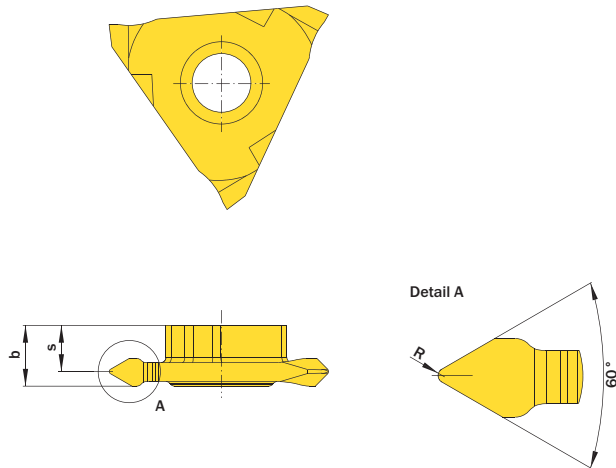


Abbildung zeigt / Drawing shows: TE3.MT20.01 EM R

Steigung (von) Pitch (as of)	Artikelnummer Part number	Webcode www.simtek.com/webcode	Unsere erste Wahl Our first choice		Steigung (bis) Pitch (up to)	b	R	S	Connectcode www.simtek.com/code			
			P	K							M	S
0,5	TE3.MT05.01 EM R/L	R ATWJ L ATTY	X800	X600	1,0	5,6	0,07	4,7	R	TE3.R.5.3	L	TE3.L.5.3
1,0	TE3.MT10.01 EM R/L	R AECT L AKJ3	X800	X600	1,5	5,6	0,14	4,6	R	TE3.R.5.3	L	TE3.L.5.3
1,25	TE3.MT12.01 EM R/L	R AJSY L AA7M	X800	X600	1,75	5,6	0,18	4,5	R	TE3.R.5.3	L	TE3.L.5.3
1,5	TE3.MT15.01 EM R/L	R AP1X L ANZ6	X800	X600	2,0	5,8	0,2	4,4	R	TE3.R.5.3	L	TE3.L.5.3
1,75	TE3.MT17.01 EM R/L	R AGJZ L AJZA	X800	X600	2,5	5,6	0,25	4,1	R	TE3.R.5.3	L	TE3.L.5.3
2,0	TE3.MT20.01 EM R/L	R AHCM L AAJY	X800	X600	2,5	5,6	0,29	4,1	R	TE3.R.5.3	L	TE3.L.5.3
2,5	TE3.MT25.01 EM R/L	R AB76 L AH2Z	X800	X600	3,0	5,6	0,36	3,9	R	TE3.R.5.3	L	TE3.L.5.3
3,0	TE3.MT30.01 EM R/L	R ANB7 L APBE	X800	X600	3,5	5,6	0,43	3,8	R	TE3.R.5.3	L	TE3.L.5.3
3,5	TE3.MT35.01 EM R/L	R AN82 L AKZ2	X800	X600	4,0	5,6	0,51	3,0	R	TE3.R.5.3	L	TE3.L.5.3
3,0	TE3.MT60.01 EM R/L	R AHBQ L AC7V	X800	X600	6,0	5,85	0,43	3,0	R	TE3.R.5.3	L	TE3.L.5.3

Bestellbeispiel // Order example: **TE3.MT10.01 EM R X800** (R = Rechte Ausführung // Right hand version, X800 = Schneidstoff // Grade)

Bitte beachten Sie die zusätzlichen Hinweise im Infobereich rechts oben.
 Please read the additional notes mentioned in the information area on the top right corner of this page.

Gewindedrehen, Metr. ISO, Innen, Vollprofil

Herstellung des vollständigen Gewindeprofils mit notwendiger Tiefe.

Threading, Metr. ISO, internal, full profile

For a complete thread profile with correct depth.

Schnittwerte (Start) // Cutting parameters (start)

Anzahl Durchgänge // Number of passes
10 - 16

Empf. Zustellungsart // Recom. infeed method
Flankenzustellung // Flank infeed (Seite/Page 433)

Vc Seite/Page **429**

Passende Klemmhalter auf Seite // Suitable toolholders on page
323, 324, 325, 326, 327, 328



SP
HM
R

Legende
 Legend **354**

Scan
 QR-Code

Oder besuchen Sie // Or Visit
www.simtek.info/cp/315

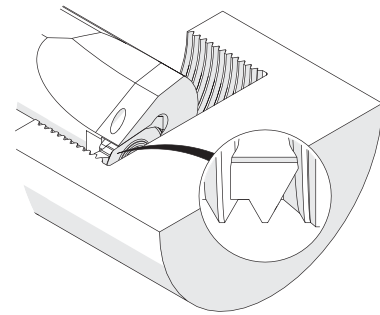
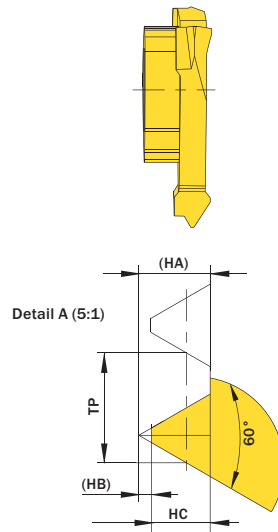
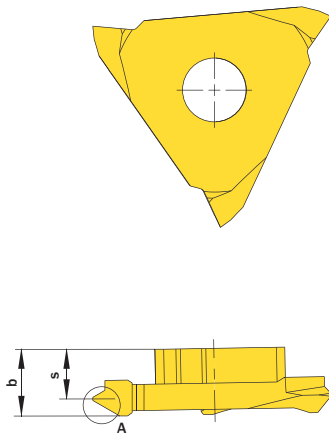


Abbildung zeigt / Drawing shows: TE3.MT20.02 IM R

Steigung TP Pitch TP	Artikelnummer Part number	Webcode www.simtek.com/webcode	Unsere erste Wahl Our first choice				b	HC	HA	HB	S	Connectcode www.simtek.com/ccode		
			P	K	M	S						R	L	
1,0	TE3.MT10.02 IM R/L	R ABMX L AGUZ	X800	X400	5,6	0,541	0,65	0,108	0,108	4,65	R TE3.R.5.3	L TE3.L.5.3	new	
1,5	TE3.MT15.02 IM R/L	R AMJ3 L AA52	X800	X400	5,6	0,812	0,974	0,162	0,162	4,45	R TE3.R.5.3	L TE3.L.5.3	new	
2,0	TE3.MT20.02 IM R/L	R AKWM L ABCA	X800	X400	5,6	1,083	1,299	0,217	0,217	4,25	R TE3.R.5.3	L TE3.L.5.3	new	
2,5	TE3.MT25.02 IM R/L	R AH53 L AM98	X800	X400	5,6	1,353	1,624	0,271	0,271	4,1	R TE3.R.5.3	L TE3.L.5.3	new	
3,0	TE3.MT30.02 IM R/L	R ABUE L AGEJ	X800	X400	5,6	1,624	1,949	0,325	0,325	3,85	R TE3.R.5.3	L TE3.L.5.3	new	
3,5	TE3.MT35.02 IM R/L	R AFW4 L AA9U	X800	X400	5,6	1,894	2,273	0,379	0,379	3,85	R TE3.R.5.3	L TE3.L.5.3	new	

Bestellbeispiel // Order example: **TE3.MT15.02 IM R X800** (R = Rechte Ausführung // Right hand version, X800 = Schneidstoff // Grade)

simturn AX
 simturn DX
 simturn PX
 simturn H2
 simturn K2
 simturn C4
 simturn GX
 simturn E3
 simturn E12
 simturn FX
 simturn Decolletage
 simturn OA
 Index

Gewindedrehen, Außen, UN Vollprofil

Herstellung des vollständigen Gewindeprofils mit notwendiger Tiefe sowie Kopf- und Fußradien. Für Außenbearbeitung.

Threading, External, UN Full Profile

For a complete thread profile with correct depth, top radius and bottom radius. For external application.

Schnittwerte (Start) // Cutting parameters (start)

Anzahl Durchgänge // Number of passes
8 - 12

Empf. Zustellungsart // Recom. infeed method
Flankenzustellung // Flank infeed (Seite/Page 433)

Vc Seite/Page **429**

Passende Klemmhalter auf Seite // Suitable toolholders on page

323, 324, 325, 326, 327, 328



Legende
 Legend **354**



Scan
 QR-Code

Oder besuchen Sie // Or Visit
www.simtek.info/cp/847

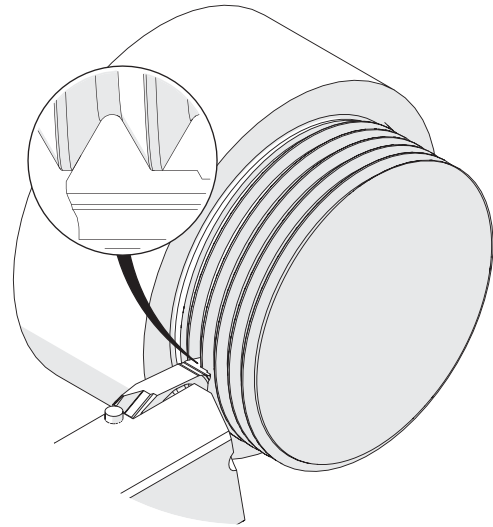
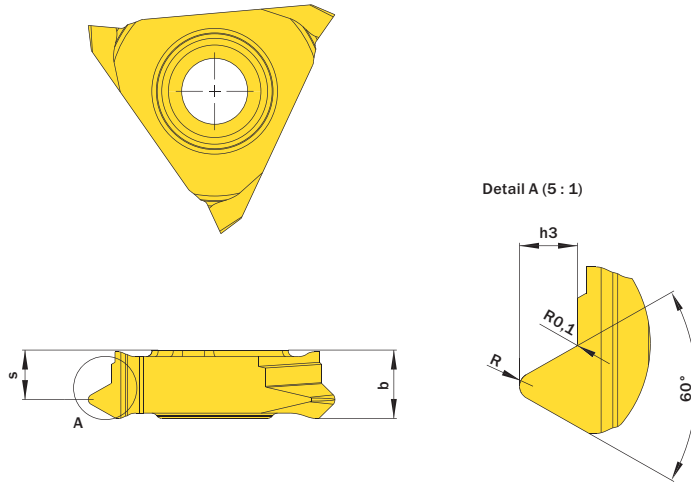


Abbildung zeigt / Drawing shows: TE3.UN08.02 EM R

Gang/Zoll Threads/inch	Artikelnummer Part number	Webcode www.simtek.com/webcode	Unsere erste Wahl Our first choice				b	h3	R	S	Connectcode www.simtek.com/code
			P	K	M	S					
8	TE3.UN08.02 EM R	AS82	X800	X600		5,8	1,95	0,46	4,1	TE3.R.5.3	
9	TE3.UN09.02 EM R	ATWP	X800	X600		5,8	1,73	0,41	4,3	TE3.R.5.3	
10	TE3.UN10.02 EM R	AS84	X800	X600		5,8	1,56	0,37	4,4	TE3.R.5.3	
11	TE3.UN11.02 EM R	ATWS	X800	X600		5,8	1,42	0,33	4,5	TE3.R.5.3	
12	TE3.UN12.02 EM R	ATWU	X800	X600		5,8	1,3	0,31	4,6	TE3.R.5.3	
14	TE3.UN14.02 EM R	AS86	X800	X600		5,8	1,11	0,26	4,7	TE3.R.5.3	
16	TE3.UN16.02 EM R	AS88	X800	X600		5,8	0,97	0,23	4,8	TE3.R.5.3	
18	TE3.UN18.02 EM R	AS9A	X800	X600		5,8	0,87	0,2	4,9	TE3.R.5.3	
20	TE3.UN20.02 EM R	AS9C	X800	X600		5,8	0,78	0,18	5,0	TE3.R.5.3	
24	TE3.UN24.02 EM R	AS9E	X800	X600		5,8	0,65	0,15	5,0	TE3.R.5.3	
28	TE3.UN28.02 EM R	AS9G	X800	X600		5,8	0,56	0,13	5,1	TE3.R.5.3	
32	TE3.UN32.02 EM R	AS9J	X800	X600		5,8	0,49	0,11	5,2	TE3.R.5.3	

Bestellbeispiel // Order example: **TE3.UN28.02 EM R X800** (R = Rechte Ausführung // Right hand version, X800 = Schneidstoff // Grade)

Gewindedrehen, Innen, UN Vollprofil

Herstellung des vollständigen Gewindeprofils mit notwendiger Tiefe. Für Innenbearbeitung.

Threading, Internal, UN Full Profile

For a complete thread profile with correct depth.
 For internal application.

Schnittwerte (Start) // Cutting parameters (start)

Anzahl Durchgänge // Number of passes
10 - 16

Empf. Zustellungsart // Recom. infeed method
Flankenzustellung // Flank infeed (Seite/Page 433)

Vc Seite/Page **429**

Passende Klemmhalter auf Seite // Suitable toolholders on page
323, 324, 325, 326, 327, 328



SP
HM

R



Legende
 Legend **354**

Scan
 QR-Code

Oder besuchen Sie // Or Visit
www.simtek.info/cp/864

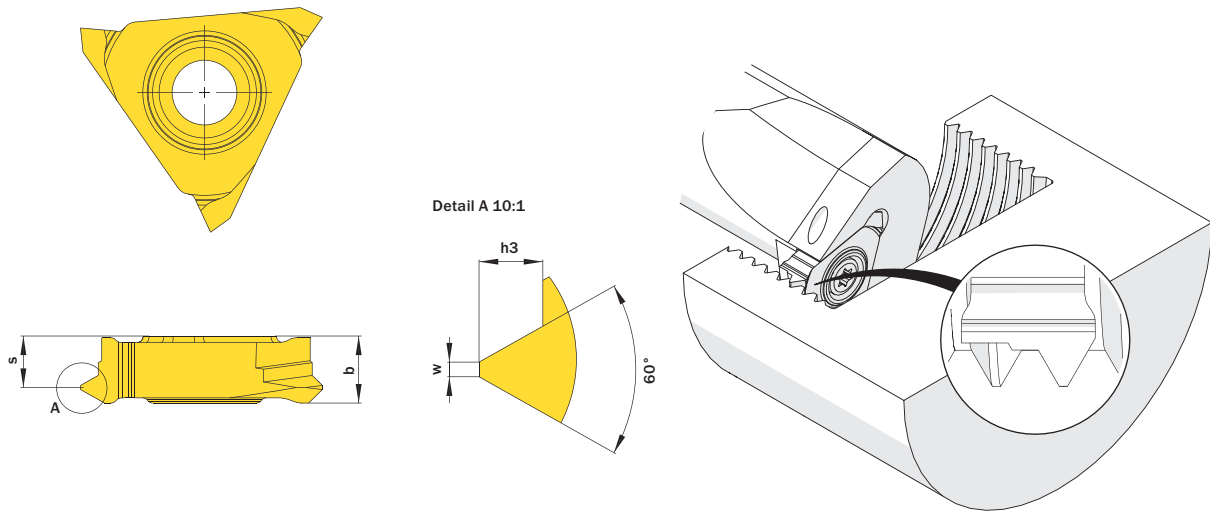


Abbildung zeigt / Drawing shows: TE3.UN09.02 IM R

Gang/Zoll Threads/Inch	Artikelnummer Part number	Webcode www.simtek.com/webcode	Unsere erste Wahl Our first choice				b	h3	S	w	Connectcode www.simtek.com/ccode
			P	K	M	S					
8	TE3.UN08.02 IM R	ATWW	X800	X400		5,8	1,72	4,3	0,4	TE3.R.5.3	
9	TE3.UN09.02 IM R	ATWY	X800	X400		5,8	1,53	4,5	0,35	TE3.R.5.3	
10	TE3.UN10.02 IM R	ATW0	X800	X400		5,8	1,37	4,6	0,32	TE3.R.5.3	
11	TE3.UN11.02 IM R	ATW2	X800	X400		5,8	1,25	4,6	0,29	TE3.R.5.3	
12	TE3.UN12.02 IM R	ATW4	X800	X400		5,8	1,15	4,7	0,26	TE3.R.5.3	

Bestellbeispiel // Order example: **TE3.UN12.02 IM R X800** (R = Rechte Ausführung // Right hand version, X800 = Schneidstoff // Grade)

simturn AX
 simturn DX
 simturn PX
 simturn H2
 simturn K2
 simturn C4
 simturn GX
 simturn E3
 simturn E12
 simturn FX
 simturn Decolletage
 simturn OA
 Index

Drehbearbeitung innen & außen // Internal and External Grooving and Turning
 simturn E3 > Schneidwerkzeug // Cutting Tool

simturnE3
 SIMTEK small part machining type E3

Gewindedrehen, Whitworth, Vollprofil

Herstellung des vollständigen Gewindeprofils mit notwendiger Tiefe sowie Kopf- und Fußradien. Für Innen- und Außenbearbeitung.

Threading, Whitworth, Full Profile

For a complete thread profile with correct depth, top radius and bottom radius. For internal and external application.

Schnittwerte (Start) // Cutting parameters (start)

Anzahl Durchgänge (außen) // Number of passes (external) **8 - 12**

Anzahl Durchgänge (innen) // Number of passes (internal) **10 - 16**

Empf. Zustellungsart // Recom. infeed method
Flankenzustellung // Flank infeed (Seite/Page 433)

Vc **Seite/Page 429**

Passende Klemmhalter auf Seite // Suitable toolholders on page
323, 324, 325, 326, 327, 328



SP
HM
L

Legende
 Legend **354**

Scan
 QR-Code

Oder besuchen Sie // Or Visit
www.simtek.info/cp/316

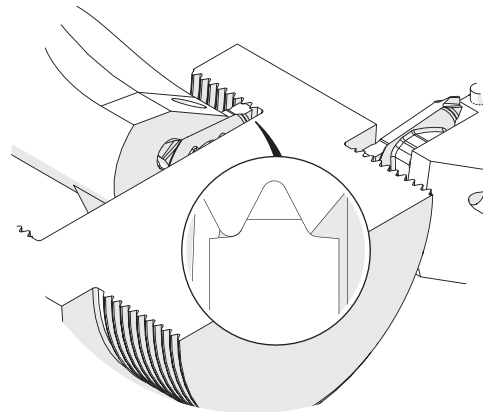
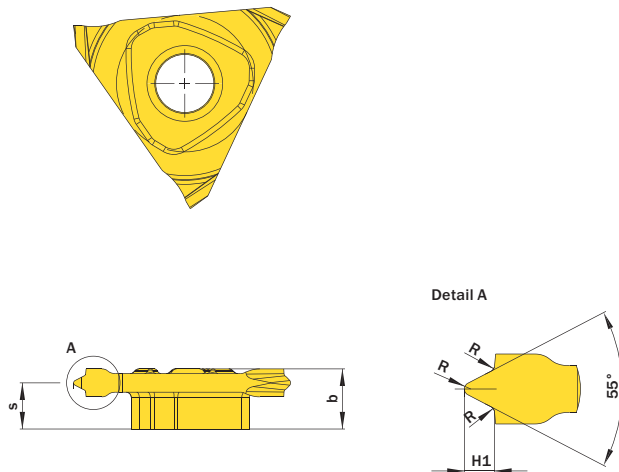


Abbildung zeigt / Drawing shows: TE3.BS14.02 ML

Gang/Zoll Threads/Inch	Artikelnummer Part number	Webcode www.simtek.com/webcode	Unsere erste Wahl Our first choice		b	H1	R	S	Connectcode www.simtek.com/ccode
			P	K M N S					
11	TE3.BS11.02 MR/L	R ANTF L ACAF	X800	X600	5,6	1,48	0,32	3,75	R TE3.R.5.3 L TE3.L.5.3
14	TE3.BS14.02 MR/L	R AJNX L AHB8	X800	X600	5,6	1,16	0,25	4,25	R TE3.R.5.3 L TE3.L.5.3
16	TE3.BS16.02 MR/L	R ACBA L AA EW	X800	X600	5,6	1,01	0,21	4,25	R TE3.R.5.3 L TE3.L.5.3
19	TE3.BS19.02 MR/L	R AJ52 L AGYG	X800	X600	5,6	0,86	0,18	4,25	R TE3.R.5.3 L TE3.L.5.3
20	TE3.BS20.02 MR/L	R ASCN L ASCP	X800	X600	5,6	0,81	0,17	4,25	R TE3.R.5.3 L TE3.L.5.3
28	TE3.BS28.02 MR/L	R ABP6 L AEMP	X800	X600	5,6	0,58	0,12	4,9	R TE3.R.5.3 L TE3.L.5.3

Bestellbeispiel // Order example: **TE3.BS14.02 MR X800** (R = Rechte Ausführung // Right hand version, X800 = Schneidstoff // Grade)

Gewindedrehen, Trapezgewinde, Vollprofil

Vollprofil mit Kantenverrundung.
 Für Innen- und Außenbearbeitung.

Threading, trapezoidal thread, full profile

Trapezoidal thread with chamfered crest.
 For internal and external application.

Schnittwerte (Start) // Cutting parameters (start)
Anzahl Durchgänge (außen) // Number of passes (external) 10 - 14
Anzahl Durchgänge (innen) // Number of passes (internal) 12 - 18
Empf. Zustellungsart // Recom. infeed method Flankenzustellung // Flank infeed (Seite/Page 433)
Vc Seite/Page 429

Passende Klemmhalter auf Seite // Suitable toolholders on page
323, 324, 325, 326, 327, 328

SP

HM

R

Legende Legend **354**

Scan QR-Code Oder besuchen Sie // Or Visit www.simtek.info/cp/317

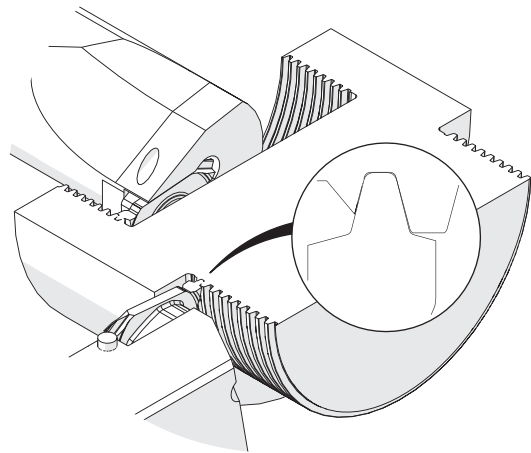
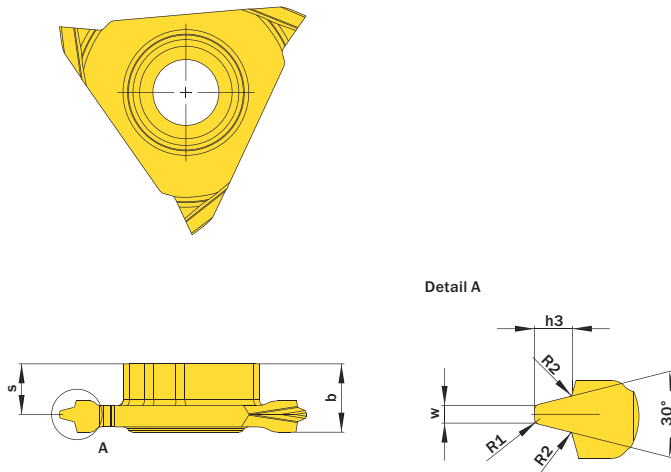


Abbildung zeigt / Drawing shows: TE3.TR20.02 MR

Steigung (von) Pitch (as of)	Artikelnummer Part number	Webcode www.simtek.com/webcode	Unsere erste Wahl Our first choice		b	h3	R1	R2	S	w	Connectcode www.simtek.com/code		
			P	K							M	S	R
1,5	TE3.TR15.02 M R/L	R AHGV L AKXY	X800	X600	5,6	0,9	0,1	0,08	4,5	0,47	R	TE3.R.5.3 L	TE3.L.5.3
2,0	TE3.TR20.02 M R/L	R AGE5 L AP3S	X800	X600	5,6	1,25	0,2	0,12	4,3	0,6	R	TE3.R.5.3 L	TE3.L.5.3
3,0	TE3.TR30.02 M R/L	R AJJA L AEXM	X800	X600	5,6	1,75	0,2	0,12	4,0	0,96	R	TE3.R.5.3 L	TE3.L.5.3
4,0	TE3.TR40.02 M R/L	R AG5K L ADDW	X800	X600	5,6	2,25	0,2	0,12	3,75	1,33	R	TE3.R.5.3 L	TE3.L.5.3
5,0	TE3.TR50.02 M R/L	R ABJQ L ABCB	X800	X600	5,6	2,75	0,2	0,12	3,25	1,7	R	TE3.R.5.3 L	TE3.L.5.3
6,0	TE3.TR60.02 M R/L	R AE29 L AD4U	X800	X600	5,6	3,5	0,4	0,25	2,75	1,93	R	TE3.R.5.3 L	TE3.L.5.3

Bestellbeispiel // Order example: **TE3.TR50.02 M R X800** (R = Rechte Ausführung // Right hand version, X800 = Schneidstoff // Grade)

simturn AX
simturn DX
simturn PX
simturn H2
simturn K2
simturn C4
simturn GX
simturn E3
simturn E12
simturn FX
simturn Decolletage
simturn OA
Index

Gewindedrehen, ACME, Teilprofil

Für ACME-Gewindeprofile. Für Innen- und Außenbearbeitung.

Threading, ACME, Partial Profile

For ACME-thread profiles. For internal and external application.

Schnittwerte (Start) // Cutting parameters (start)
Anzahl Durchgänge (außen) // Number of passes (external) 10 - 14
Anzahl Durchgänge (innen) // Number of passes (internal) 12 - 18
Empf. Zustellungsart // Recom. infeed method Flankenzustellung // Flank infeed (Seite/Page 433)
Vc Seite/Page 429

Passende Klemmhalter auf Seite // Suitable toolholders on page
323, 324, 325, 326, 327, 328

SP
HM

R

Legende Legend **354**

Scan QR-Code Oder besuchen Sie // Or Visit www.simtek.info/cp/320

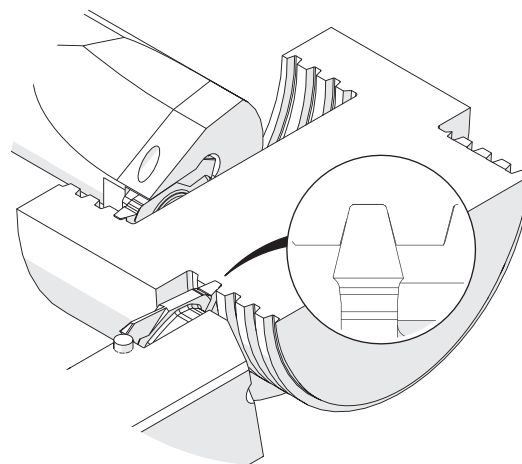
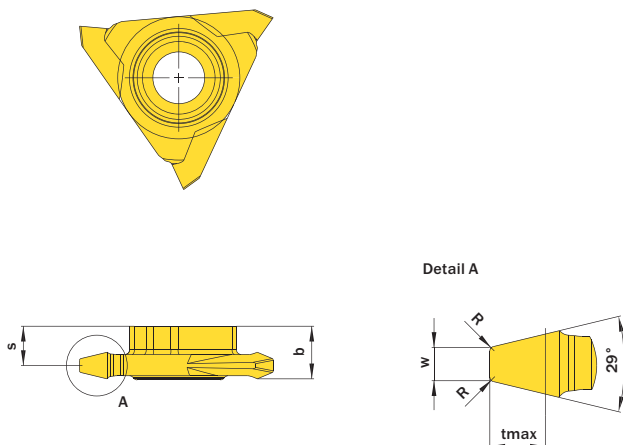


Abbildung zeigt / Drawing shows: TE3.AC06.01 MR

Gang/Zoll Threads/Inch	Artikelnummer Part number	Webcode www.simtek.com/webcode	Unsere erste Wahl Our first choice				b	R	S	tmax	w	Connectcode www.simtek.com/ccode	
			P	K	M	S						R	L
4	TE3.AC04.01 MR/L	R ANK1 L AEUB	X800	X600	5,8	0,3	3,1	3,52	2,19	R	TE3.R.5.3	L	TE3.L.5.3
5	TE3.AC05.01 MR/L	R APD5 L ANBB	X800	X600	5,8	0,2	3,65	2,83	1,74	R	TE3.R.5.3	L	TE3.L.5.3
6	TE3.AC06.01 MR/L	R AC7C L AHJK	X800	X600	5,8	0,2	4,25	2,39	1,44	R	TE3.R.5.3	L	TE3.L.5.3
8	TE3.AC08.01 MR/L	R AMJC L AA6W	X800	X600	5,8	0,15	4,6	1,83	1,06	R	TE3.R.5.3	L	TE3.L.5.3
10	TE3.AC10.01 MR/L	R AFH3 L AMHD	X800	X600	5,8	0,1	4,8	1,49	0,84	R	TE3.R.5.3	L	TE3.L.5.3
12	TE3.AC12.01 MR/L	R AKBD L ACM7	X800	X600	5,8	0,1	4,9	1,25	0,69	R	TE3.R.5.3	L	TE3.L.5.3
14	TE3.AC14.01 MR/L	R ANWB L AHFT	X800	X600	5,8	-	5,0	1,09	0,59	R	TE3.R.5.3	L	TE3.L.5.3
16	TE3.AC16.01 MR/L	R AACK L AH4V	X800	X600	5,8	-	5,1	0,96	0,51	R	TE3.R.5.3	L	TE3.L.5.3

Bestellbeispiel // Order example: **TE3.AC04.01 MR X800** (R = Rechte Ausführung // Right hand version, X800 = Schneidstoff // Grade)

Gewindedrehen, STUB ACME, Teilprofil

Für STUB ACME-Gewindeprofile. Für Innen- und Außenbearbeitung.

Threading, STUB ACME, Partial Profile

For STUB ACME-thread profiles. For internal and external application.

Schnittwerte (Start) // Cutting parameters (start)
Anzahl Durchgänge (außen) // Number of passes (external) 10 - 14
Anzahl Durchgänge (innen) // Number of passes (internal) 12 - 18
Empf. Zustellungsart // Recom. infeed method Flankenzustellung // Flank infeed (Seite/Page 433)
Vc Seite/Page 429

Passende Klemmhalter auf Seite // Suitable toolholders on page
323, 324, 325, 326, 327, 328

SP
HM **R**

Legende
Legend **354**

Scan QR-Code Oder besuchen Sie // Or Visit
www.simtek.info/cp/983

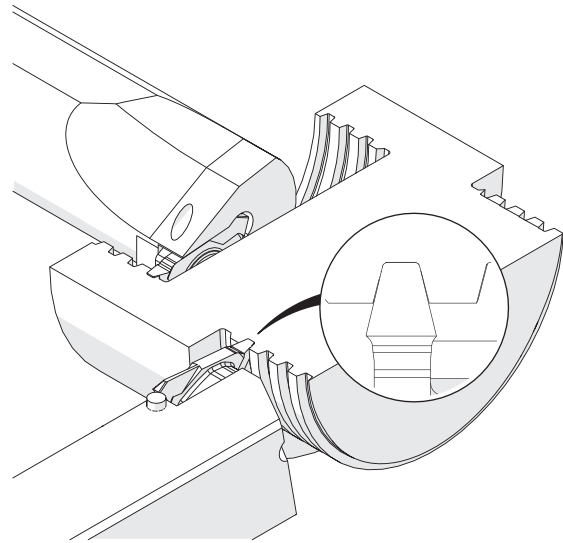
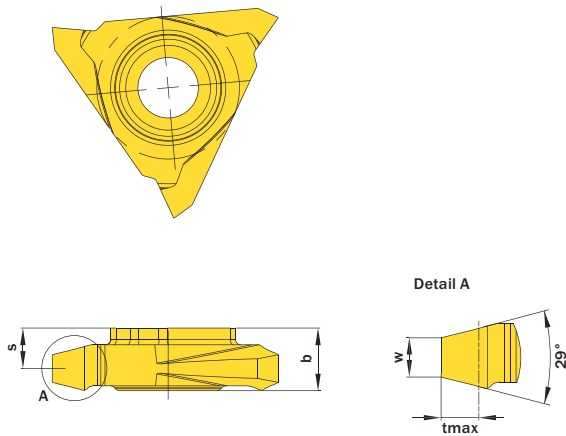


Abbildung zeigt / Drawing shows: TE3.SA04.01 MR

Gang/Zoll Threads/Inch	Artikelnummer Part number	Webcode www.simtek.com/webcode		Unsere erste Wahl Our first choice		b	S	tmax	w	Connectcode www.simtek.com/code	
		R	L	P	K					M	N
4	TE3.SA04.01 MR/L	R AVK4	L AVK3	X800	X600	5,8	3,75	2,44	2,55	R TE3.R.5.3	L TE3.L.5.3
5	TE3.SA05.01 MR/L	R AVK5	L AVK6	X800	X600	5,8	4,1	2,04	2,01	R TE3.R.5.3	L TE3.L.5.3
6	TE3.SA06.01 MR/L	R AVF7	L AVF5	X800	X600	5,8	4,4	1,76	1,65	R TE3.R.5.3	L TE3.L.5.3
8	TE3.SA08.01 MR/L	R AVF9	L AVF8	X800	X600	5,8	4,7	1,41	1,21	R TE3.R.5.3	L TE3.L.5.3
10	TE3.SA10.01 MR/L	R AVGB	L AVGA	X800	X600	5,8	4,9	1,19	0,94	R TE3.R.5.3	L TE3.L.5.3
12	TE3.SA12.01 MR/L	R AVGD	L AVGC	X800	X600	5,8	5,0	0,92	0,82	R TE3.R.5.3	L TE3.L.5.3
14	TE3.SA14.01 MR/L	R AVK8	L AVK7	X800	X600	5,8	5,1	0,82	0,7	R TE3.R.5.3	L TE3.L.5.3
16	TE3.SA16.01 MR/L	R AVMA	L AVK9	X800	X600	5,8	5,2	0,74	0,6	R TE3.R.5.3	L TE3.L.5.3

Bestellbeispiel // Order example: **TE3.SA04.01 MR X800** (R = Rechte Ausführung // Right hand version, X800 = Schneidstoff // Grade)

simturn AX
simturn DX
simturn PX
simturn H2
simturn K2
simturn C4
simturn GX
simturn E3
simturn E12
simturn FX
simturn Decolletage
simturn OA
Index

Drehbearbeitung innen & außen // Internal and External Grooving and Turning
 simturn E3 > Schneidwerkzeug // Cutting Tool

simturnE3
 SIMTEK small part machining type E3

Gewindedrehen, NPT, Vollprofil

Herstellung des vollständigen Gewindeprofils mit notwendiger Tiefe. Für Innen- und Außenbearbeitung.

Threading, NPT, Full Profile

For a complete thread profile with correct depth.
 For internal and external application.

Schnittwerte (Start) // Cutting parameters (start)

Anzahl Durchgänge (außen) // Number of passes (external) **8 - 12**

Anzahl Durchgänge (innen) // Number of passes (Internal) **10 - 16**

Empf. Zustellungsart // Recom. infeed method
Flankenzustellung // Flank infeed (Seite/Page 433)

Vc Seite/Page **429**

Passende Klemmhalter auf Seite // Suitable toolholders on page
323, 324, 325, 326, 327, 328



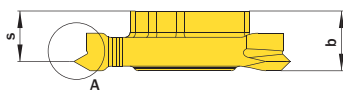
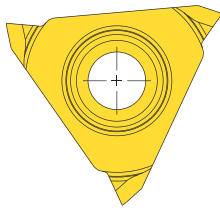
SP
HM

R

Legende
 Legend **354**

Scan
 QR-Code

Oder besuchen Sie // Or Visit
www.simtek.info/cp/345



Detail A

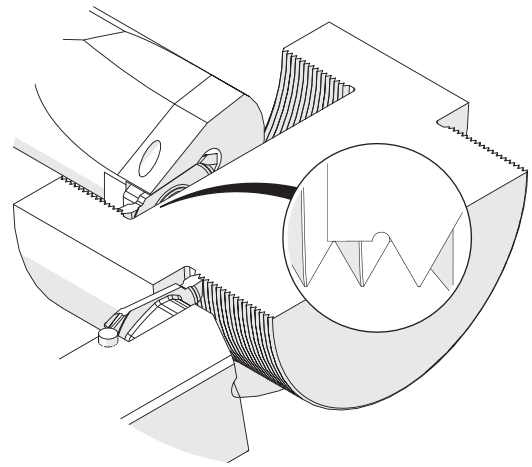
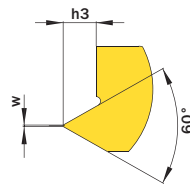


Abbildung zeigt / Drawing shows: TE3.NP18.02 M R

Gang/Zoll Threads/Inch	Artikelnummer Part number	Webcode www.simtek.com/webcode	Unsere erste Wahl Our first choice	b	h3	S	w	Connectcode www.simtek.com/code
			P K M N S	mm	mm	mm	mm	
14	TE3.NP14.02 MR	AQA4	X800 X400	5,8	1,45	4,7	0,07	TE3.R.5.3
18	TE3.NP18.02 MR	AQA6	X800 X400	5,8	1,13	4,9	0,05	TE3.R.5.3
27	TE3.NP27.02 MR	AQA9	X800 X400	5,8	0,75	5,1	0,04	TE3.R.5.3

Bestellbeispiel // Order example: **TE3.NP18.02 MR X400** (R = Rechte Ausführung // Right hand version, X400 = Schneidstoff // Grade)

Abstechen

Verfügbar in verschiedenen Winkeln,
 Breiten und mit/ohne geschliffener Spanformrinne.

Parting Off

Available in different angles,
 widths and with/without ground chip form channel.

Schnittwerte (Start) // Cutting parameters (start)	
f (außen//ext.) 0,08 mm/U	Vc Seite/Page 429

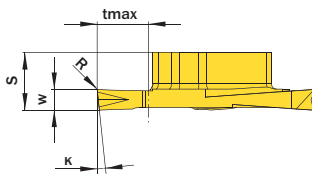
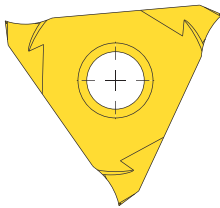
Passende Klemmhalter auf Seite // Suitable toolholders on page
323, 324, 325, 326, 327, 328

SP
HM **R**

Scan QR-Code

Legende
Legend **354**

Oder besuchen Sie // Or Visit
www.simtek.info/cp/311



Abbildungen ähnlich // Similar illustrations



! Bearbeitbare Materialien. Siehe unten.
 Machineable materials. See below.

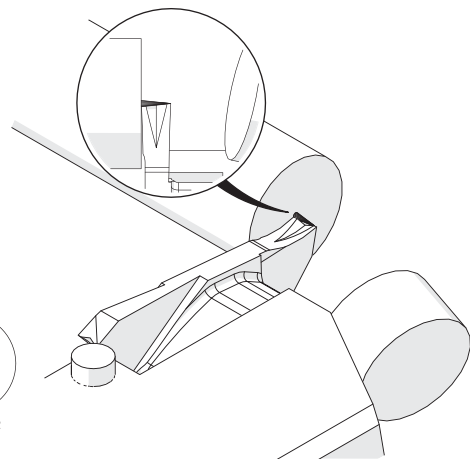


Abbildung zeigt / Drawing shows: TE3.R200.05 PT R

W ^{-0,05} mm	K	Mit Spanformrinne With chip form channel	Artikelnummer Part number	Webcode www.simtek.com/webcode	Unsere erste Wahl Our first choice	R	S	tmax	Connectcode www.simtek.com/code
					P K M N S	mm	mm	mm	
▼ w = 1,0 mm									
1,0	6°	Nein / No	TE3.R100.06 PS R	AH0U	X800 X600	0,1	5,45	5,0	TE3.R.5.3
1,0	6°	Ja / Yes	TE3.R100.06 PT R	AGJH	X800 X600	0,1	5,45	5,0	TE3.R.5.3
1,0	6°	Ja / Yes	TE3.R100.06 PV R	AU7D	X800 X600	0,1	5,45	5,0	TE3.R.5.3
1,0	12°	Nein / No	TE3.R100.12 PS R	AP4T	X800 X600	0,1	5,45	5,0	TE3.R.5.3
1,0	12°	Ja / Yes	TE3.R100.12 PT R	ACYU	X800 X600	0,1	5,45	5,0	TE3.R.5.3
1,0	12°	Ja / Yes	TE3.R100.12 PV R	AU7B	X800 X600	0,1	5,45	5,0	TE3.R.5.3
▼ w = 1,6 mm									
1,6	6°	Nein / No	TE3.R160.06 PS R	AJ3Y	X800 X600	0,1	5,6	5,0	TE3.R.5.3
1,6	6°	Ja / Yes	TE3.R160.06 PT R	AMWZ	X800 X600	0,1	5,6	5,0	TE3.R.5.3
1,6	6°	Ja / Yes	TE3.R160.06 PV R	AU7A	X800 X600	0,1	5,6	5,0	TE3.R.5.3
▼ w = 2,0 mm									
2,0	5°	Nein / No	TE3.R200.05 PS R	ANAS	X800 X600	0,1	5,6	5,0	TE3.R.5.3
2,0	5°	Ja / Yes	TE3.R200.05 PT R	AGZ7	X800 X600	0,1	5,6	5,0	TE3.R.5.3
2,0	5°	Ja / Yes	TE3.R200.05 PV R	AU69	X800 X600	0,1	5,6	5,0	TE3.R.5.3
2,0	12°	Nein / No	TE3.R200.12 PS R	A3DD	X800 X600	0,1	5,45	5,0	TE3.R.5.3 new

Bestellbeispiel // Order example: **TE3.R200.05 PT R X800** (R = Rechte Ausführung // Right hand version, X800 = Schneidstoff // Grade)

TE3.R...PS R: Für die Bearbeitung eines breiten Materialspektrums // For a wide variety of workpiece materials.

TE3.R...PT R / TE3.R...PV R:

Für die Bearbeitung eines breiten Materialspektrums sowie besonders für langspanendes Material. Bitte stimmen Sie sich im Zweifel mit unserer technischen Fachberatung ab: +49 7473 9517-140 oder support@simtek.com // For a wide variety of workpiece materials as well as especially for long-chipping materials. Please contact our technical support in case of doubt: +49 7473 9517-140 or support@simtek.com

Abstechen

Verfügbar in verschiedenen Winkeln,
 Breiten und mit/ohne geschliffener Spanformrinne.

Parting Off

Available in different angles,
 widths and with/without ground chip form channel.

Schnittwerte (Start) // Cutting parameters (start)

f (außen//ext.) 0,08 mm/U	Vc Seite/Page 429
-------------------------------------	-----------------------------

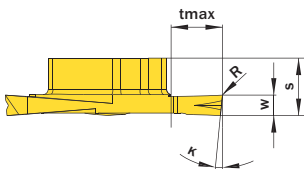
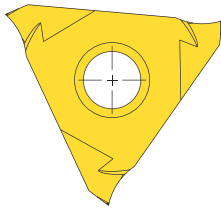
Passende Klemmhalter auf Seite // Suitable toolholders on page
323, 324, 325, 326, 327, 328



Legende
 Legend **354**

Scan
 QR-Code

Oder besuchen Sie // Or Visit
www.simtek.info/cp/324



Abbildungen ähnlich // Similar illustrations



TE3.L...PS L



TE3.L...PT L



TE3.L...PV L

! Bearbeitbare Materialien. Siehe unten.
 Machineable materials. See below.

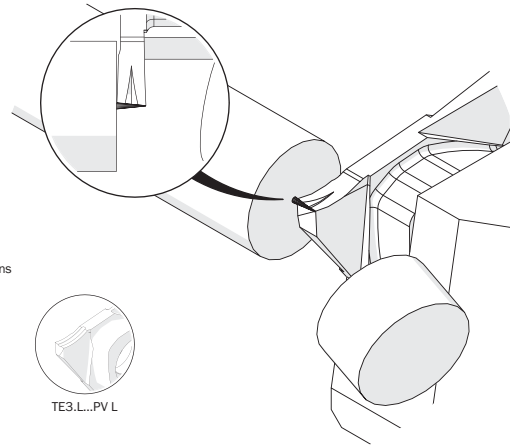


Abbildung zeigt / Drawing shows: TE3.L200.05 PT L

W ^{-0,05} mm	K	Mit Spanformrinne With chip form channel	Artikelnummer Part number	Webcode www.simtek.com/webcode	Unsere erste Wahl Our first choice	R	S	tmax	Connectcode www.simtek.com/code
					P K M N S	mm	mm	mm	
▼ w = 1,0 mm									
1,0	6°	Nein / No	TE3.L100.06 PS L	ABKC	X800 X600	0,1	5,45	5,0	TE3.L.5.3
1,0	6°	Ja / Yes	TE3.L100.06 PT L	ATXW	X800 X600	0,1	5,45	5,0	TE3.L.5.3
1,0	6°	Ja / Yes	TE3.L100.06 PV L	AU7M	X800 X600	0,1	5,45	5,0	TE3.L.5.3
1,0	12°	Nein / No	TE3.L100.12 PS L	AP4S	X800 X600	0,1	5,45	5,0	TE3.L.5.3
1,0	12°	Ja / Yes	TE3.L100.12 PT L	ATXV	X800 X600	0,1	5,45	5,0	TE3.L.5.3
▼ w = 1,6 mm									
1,6	6°	Nein / No	TE3.L160.06 PS L	APPB	X800 X600	0,1	5,6	5,0	TE3.L.5.3
1,6	6°	Ja / Yes	TE3.L160.06 PT L	AMW5	X800 X600	0,1	5,6	5,0	TE3.L.5.3
1,6	6°	Ja / Yes	TE3.L160.06 PV L	AU7K	X800 X600	0,1	5,6	5,0	TE3.L.5.3
1,6	12	Ja / Yes	TE3.L160.12 PT L	A2P0	X800 X600	0,1	5,6	5,0	TE3.L.5.3
▼ w = 2,0 mm									
2,0	5°	Nein / No	TE3.L200.05 PS L	AH4K	X800 X600	0,1	5,6	5,0	TE3.L.5.3
2,0	5°	Ja / Yes	TE3.L200.05 PT L	AHAU	X800 X600	0,1	5,6	5,0	TE3.L.5.3
2,0	5°	Ja / Yes	TE3.L200.05 PV L	AU7F	X800 X600	0,1	5,6	5,0	TE3.L.5.3
2,0	12	Ja / Yes	TE3.L200.12 PT L	A2P1	X800 X600	0,1	5,6	5,0	TE3.L.5.3

! Bestellbeispiel // Order example: **TE3.L160.06 PT L X800** (L = Linke Ausführung // Left hand version, X800 = Schneidstoff // Grade)

! TE3.L...PS L: Für die Bearbeitung eines breiten Materialspektrums // For a wide variety of workpiece materials.

! TE3.L...PT L / TE3.L...PV L:

Für die Bearbeitung eines breiten Materialspektrums sowie besonders für langspanendes Material. Bitte stimmen Sie sich im Zweifel mit unserer technischen Fachberatung ab: +49 7473 9517-140 oder support@simtek.com // For a wide variety of workpiece materials as well as especially for long-chipping materials. Please contact our technical support in case of doubt: +49 7473 9517-140 or support@simtek.com

Abstechen

Verfügbar in verschiedenen Winkeln,
 Breiten und mit/ohne geschliffene Spanformrinne.

Parting Off

Available in different angles,
 widths and with/without ground chip form channel.

Schnittwerte (Start) // Cutting parameters (start)	
f (außen//ext.) 0,08 mm/U	Vc Seite/Page 429

Passende Klemmhalter auf Seite // Suitable toolholders on page
323, 324, 325, 326, 327, 328

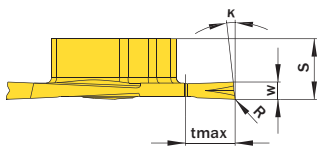
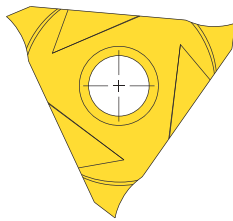
SP
HM

L

Legende
Legend

354

Scan QR-Code
 Oder besuchen Sie // Or Visit www.simtek.info/cp/326



Abbildungen ähnlich // Similar illustrations



! Bearbeitbare Materialien. Siehe unten.
 Machineable materials. See below.

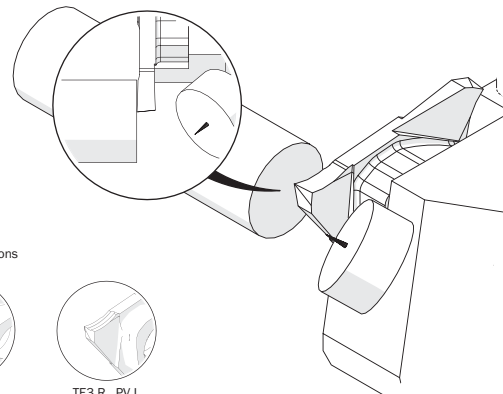


Abbildung zeigt / Drawing shows: TE3.R160.06 PT L

w ^{-0,05} mm	K	Mit Spanformrinne With chip form channel	Artikelnummer Part number	Webcode www.simtek.com/webcode	Unsere erste Wahl Our first choice	R	S	tmax	Connectcode www.simtek.com/code
					P K M N S	mm	mm	mm	
▼ w = 1,0 mm									
1,0	6°	Nein / No	TE3.R100.06 PS L	AE0Y	X800 X600	0,1	5,45	5,0	TE3.L.5.3
▼ w = 1,6 mm									
1,6	6°	Nein / No	TE3.R160.06 PS L	AHQ A	X800 X600	0,1	5,6	5,0	TE3.L.5.3
1,6	6°	Ja / Yes	TE3.R160.06 PT L	AJNP	X800 X600	0,1	5,6	5,0	TE3.L.5.3
1,6	6°	Ja / Yes	TE3.R160.06 PV L	AU7C	X800 X600	0,1	5,6	5,0	TE3.L.5.3
▼ w = 2,0 mm									
2,0	5°	Nein / No	TE3.R200.05 PS L	AA8H	X800 X600	0,1	5,6	5,0	TE3.L.5.3
2,0	5°	Ja / Yes	TE3.R200.05 PT L	AHYQ	X800 X600	0,1	5,6	5,0	TE3.L.5.3
2,0	5°	Ja / Yes	TE3.R200.05 PV L	AU7E	X800 X600	0,1	5,6	5,0	TE3.L.5.3

Bestellbeispiel // Order example: **TE3.R160.06 PS L X800** (L = Linke Ausführung // Left hand version, X800 = Schneidstoff // Grade)

TE3.R...PS L: Für die Bearbeitung eines breiten Materialspektrums // For a wide variety of workpiece materials.

TE3.R...PT L / TE3.R...PV L:

Für die Bearbeitung eines breiten Materialspektrums sowie besonders für langspanendes Material. Bitte stimmen Sie sich im Zweifel mit unserer technischen Fachberatung ab: +49 7473 9517-140 oder support@simtek.com // For a wide variety of workpiece materials as well as especially for long-chipping materials. Please contact our technical support in case of doubt: +49 7473 9517-140 or support@simtek.com

Axialstechen

Für die Herstellung von Axialnuten.
 Bitte beachten Sie die Freiwinkel.

Face Grooving

For face grooves in different widths.
 Available with different clearance angles.

Schnittwerte (Start) // Cutting parameters (start)

f (außen//ext.) 0,04 mm/U	Vc Seite/Page 429
------------------------------	----------------------

Passende Klemmhalter auf Seite // Suitable toolholders on page
323, 324, 325, 326, 327, 328

SP
HM

R

Legende
Legend

354

Scan QR-Code

Oder besuchen Sie // Or Visit
www.simtek.info/cp/327

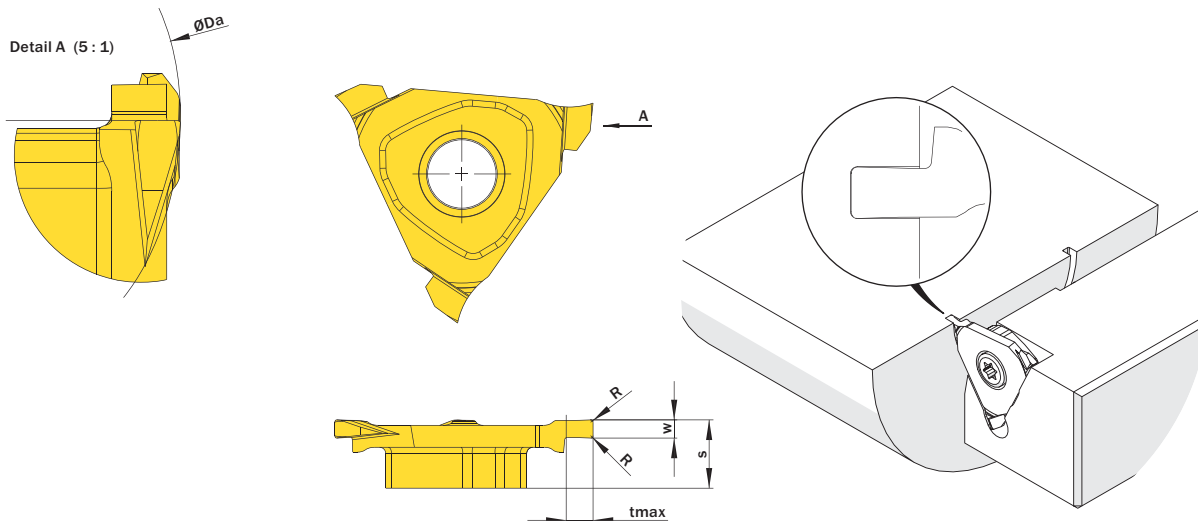


Abbildung zeigt / Drawing shows: TE3.R150.020 AG R

$w \pm 0,02$ mm	R mm	Artikelnummer Part number	Webcode www.simtek.com/webcode	Unsere erste Wahl Our first choice	$\varnothing Da$ mm	S mm	$tmax$ mm	Connectcode www.simtek.com/code
1,5	0,2	TE3.R150.020 AG R	AF5U	P K M N S	30,0	5,6	2,0	TE3.R.5.3
2,0	0,2	TE3.R200.020 AG R	AFVU	X800 X600	30,0	5,6	3,0	TE3.R.5.3
3,0	0,2	TE3.R300.020 AG R	ANNM	X800 X600	30,0	5,6	3,0	TE3.R.5.3

Bestellbeispiel // Order example: **TE3.R300.020 AG R X800** (R = Rechte Ausführung // Right hand version, X800 = Schneidstoff // Grade)

Axialstechen

Für die Herstellung von Axialnuten.
 Bitte beachten Sie die Freiwinkel.

Face Grooving

For face grooves in different widths.
 Please pay attention to the clearance angles.

Schnittwerte (Start) // Cutting parameters (start)

f (außen//ext.) 0,04 mm/U	Vc Seite/Page 429
-------------------------------------	-----------------------------

Passende Klemmhalter auf Seite // Suitable toolholders on page
323, 324, 325, 326, 327, 328

SP

HM

L

354

Legende
Legend

Scan QR-Code Oder besuchen Sie // Or Visit
www.simtek.info/cp/328

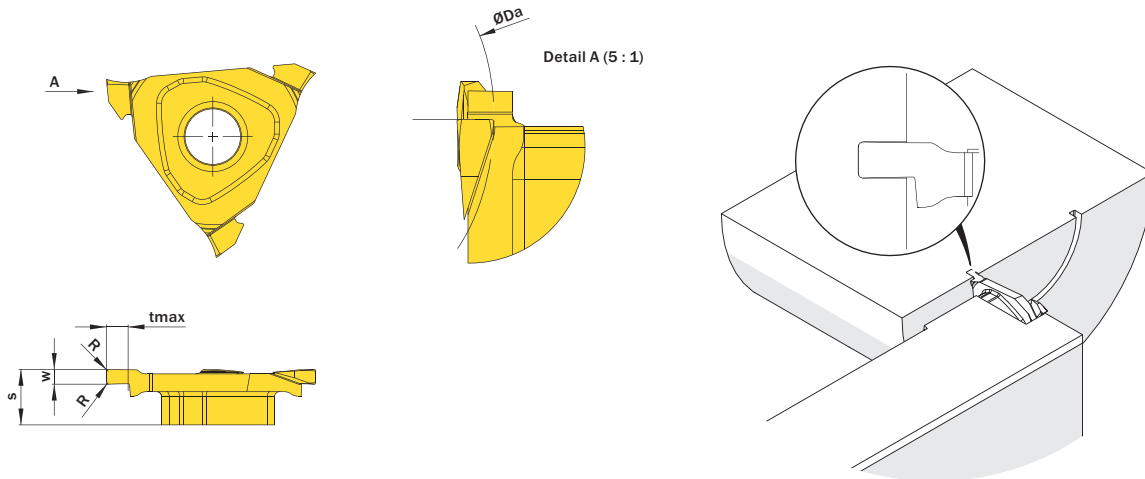


Abbildung zeigt / Drawing shows: TE3.R150.020 AG L

$w \pm 0,02$	R	Artikelnummer Part number	Webcode www.simtek.com/webcode	Unsere erste Wahl Our first choice	$\varnothing Da$	S	tmax	Connectcode www.simtek.com/ccode
mm	mm			P K M N S	mm	mm	mm	
1,5	0,2	TE3.R150.020 AG L	AE96	X800 X600	20,0	5,6	2,0	TE3.L.5.3
2,0	0,2	TE3.R200.020 AG L	ADYQ	X800 X600	30,0	5,6	3,0	TE3.L.5.3
3,0	0,2	TE3.R300.020 AG L	APTH	X800 X600	30,0	5,6	3,0	TE3.L.5.3

Bestellbeispiel // Order example: **TE3.R200.020 AG L X800** (L = Linke Ausführung // Left hand version, X800 = Schneidstoff // Grade)

Axialstechen

Für die Herstellung von Axialnuten.
 Bitte beachten Sie die Freiwinkel.

Face Grooving

For face grooves in different widths.
 Please pay attention to the clearance angles.

Schnittwerte (Start) // Cutting parameters (start)

f (außen//ext.) 0,04 mm/U	Vc Seite/Page 429
------------------------------	----------------------

Passende Klemmhalter auf Seite // Suitable toolholders on page
323, 324, 325, 326, 327, 328

SP
HM

L

Legende
Legend

354

Scan QR-Code Oder besuchen Sie // Or Visit
www.simtek.info/cp/330

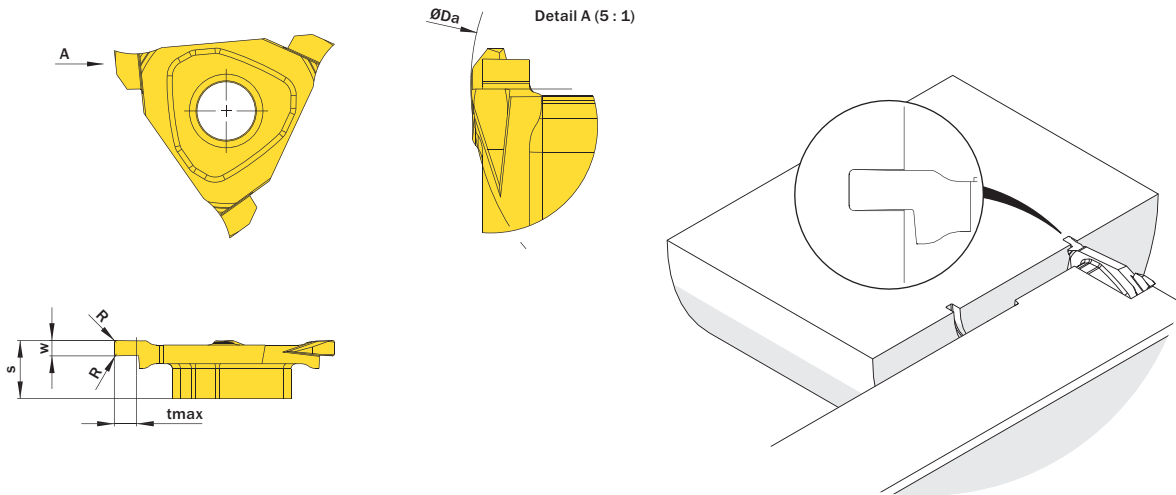


Abbildung zeigt / Drawing shows: TE3.L150.020 AG L

$w \pm 0,02$ mm	R mm	Artikelnummer Part number	Webcode www.simtek.com/webcode	Unsere erste Wahl Our first choice	$\varnothing Da$ mm	S mm	tmax mm	Connectcode www.simtek.com/code
				P K M N S				
1,5	0,2	TE3.L150.020 AG L	AAU1	X800 X600	20,0	5,6	2,0	TE3.L.5.3
2,0	0,2	TE3.L200.020 AG L	AB5A	X800 X600	30,0	5,6	3,0	TE3.L.5.3
3,0	0,2	TE3.L300.020 AG L	ACF5	X800 X600	30,0	5,6	3,0	TE3.L.5.3

Bestellbeispiel // Order example: **TE3.L150.020 AG L X800** (L = Linke Ausführung // Left hand version, X800 = Schneidstoff // Grade)

Axialstechen

Für die Herstellung von Axialnuten.
 Bitte beachten Sie die Freiwinkel.

Face Grooving

For face grooves in different widths.
 Please pay attention to the clearance angles.

Schnittwerte (Start) // Cutting parameters (start)

f (außen//ext.) 0,04 mm/U	Vc Seite/Page 429
------------------------------	----------------------

Passende Klemmhalter auf Seite // Suitable toolholders on page
323, 324, 325, 326, 327, 328

SP

HM

R

Legende
Legend

354

Scan QR-Code
 Oder besuchen Sie // Or Visit
www.simtek.info/cp/329

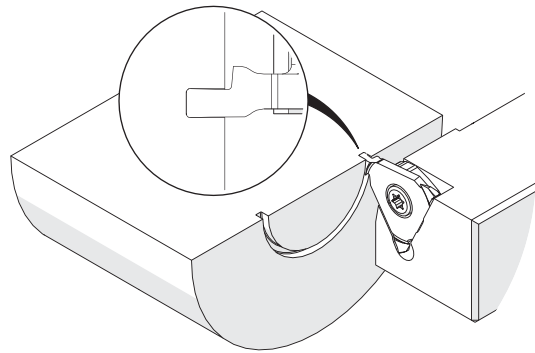
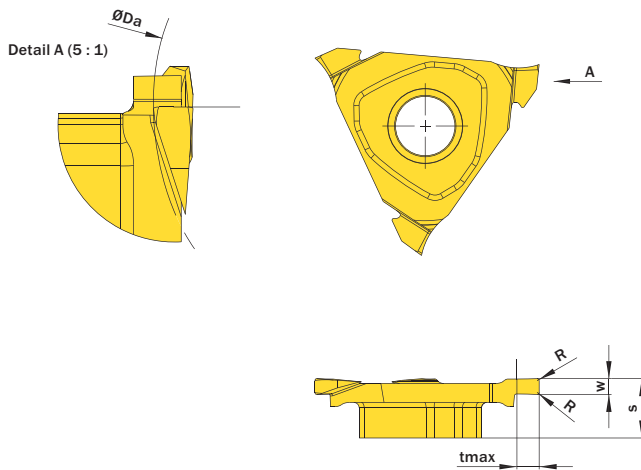


Abbildung zeigt / Drawing shows: TE3.L150.020 AG R

$w \pm 0,02$	R	Artikelnummer Part number	Webcode www.simtek.com/webcode	Unsere erste Wahl Our first choice	$\varnothing Da$	S	t_{max}	Connectcode www.simtek.com/ccode
mm	mm			P K M N S	mm	mm	mm	
1,5	0,2	TE3.L150.020 AG R	ABWV	X800 X600	20,0	5,6	2,0	TE3.R.5.3
2,0	0,2	TE3.L200.020 AG R	AACH	X800 X600	30,0	5,6	3,0	TE3.R.5.3
3,0	0,2	TE3.L300.020 AG R	AK3P	X800 X600	30,0	5,6	3,0	TE3.R.5.3

Bestellbeispiel // Order example: **TE3.L200.020 AG R X800** (R = Rechte Ausführung // Right hand version, X800 = Schneidstoff // Grade)

Poly-V-Riemennuten

Für Poly-V-Profile J, K und L.

Poly-V-Belt Grooves

For Poly-V-profiles J, K and L.

Schnittwerte (Start) // Cutting parameters (start)

f (außen//ext.) 0,04 mm/U	Vc Seite/Page 429
-------------------------------------	-----------------------------

Passende Klemmhalter auf Seite // Suitable toolholders on page
323, 324, 325, 326, 327, 328

SP

HM

R

Legende
 Legend

354

Oder besuchen Sie // Or Visit
www.simtek.info/cp/344

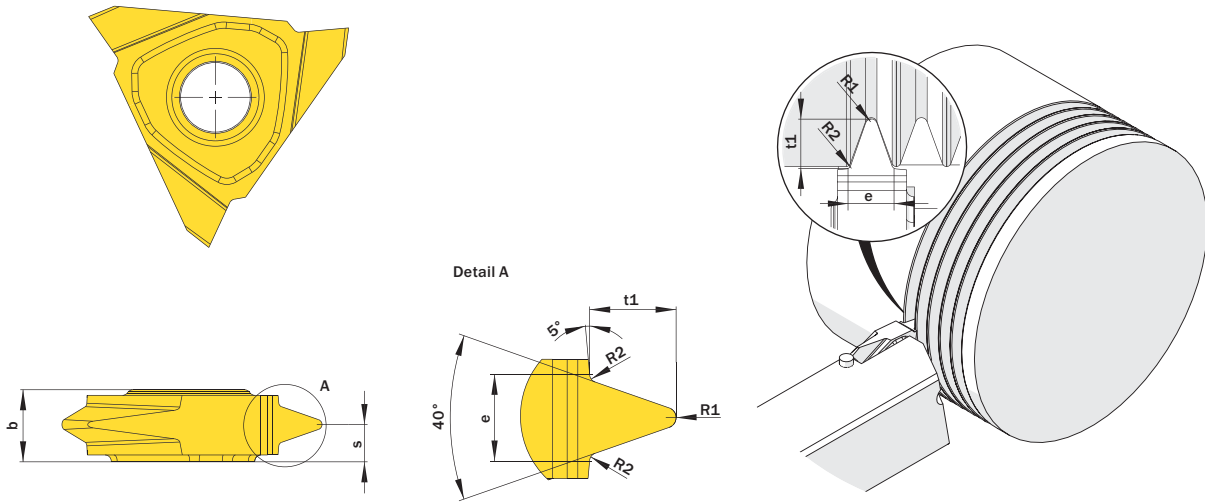


Abbildung zeigt / Drawing shows: TE3.0356.00 JR

e ±0,025 mm	Artikelnummer Part number	Webcode www.simtek.com/webcode		Unsere erste Wahl Our first choice		Profil Profile	b mm	R1 mm	R2 mm	S mm	t1 mm	Connectcode www.simtek.com/code	
		R	L	P	K							M	N
2,34	TE3.0223.00 JR/L	R AHDF	L AK8P	X800	X600	J	5,8	0,25	0,2	4,25	2,3	R TE3.R.5.3	L TE3.L.5.3
3,56	TE3.0356.00 JR/L	R AB95	L AP4U	X800	X600	K	5,8	0,35	0,25	3,45	3,69	R TE3.R.5.3	L TE3.L.5.3
4,7	TE3.0470.00 JR/L	R AP4W	L AP4V	X800	X600	L	5,45	0,33	0,4	2,72	5,02	R TE3.R.5.3	L TE3.L.5.3

Bestellbeispiel // Order example: **TE3.0356.00 JR X800** (R = Rechte Ausführung // Right hand version, X800 = Schneidstoff // Grade)

Hinweisliste Additional information

T01

Bei den simturn Teilprofil-Gewindeschneidplatten für metrische ISO-Gewinde handelt es sich um Mehrbereichswerkzeuge, d.h. dass mit einem Werkzeug unterschiedliche Steigungen gefertigt werden können.

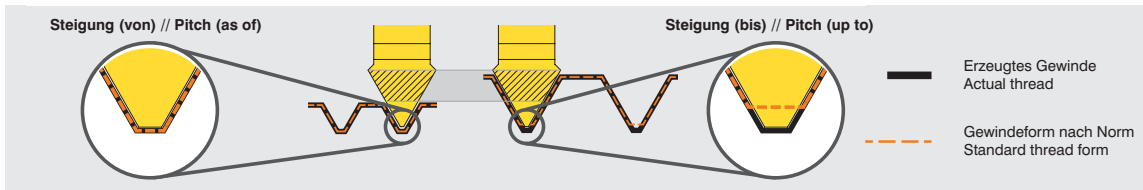
Das Schneidwerkzeug ist dabei immer auf die angegebene „Steigung (von)“ ausgelegt, wodurch ein normgerechtes Gewinde beim Fertigen dieser Steigung entsteht.

Die ebenfalls angegebene „Steigung (bis)“ kann mit diesem Werkzeug ebenfalls gefertigt werden. Es entsteht hierbei jedoch ein - gegenüber der Norm - geringfügig tieferes Gewinde. Die geringfügig höhere Gewindetiefe ist i.d.R. akzeptabel, es muss jedoch immer der Einzelfall beurteilt werden.

The simturn threading inserts with partial profile for metric ISO-threads are multi-purpose tools. This means that each insert is offering the possibility to machine different pitches.

The insert is always designed to meet the pitch given as „Pitch (as of)“: Machining this pitch will result in a standard conform thread form.




The given „Pitch (up to)“ can be machined too with this insert at the expense of standard conformity: The resulting thread will be slightly deeper than the standard. The deeper thread is usually acceptable, but the application and use needs to be evaluated.



Beispiel // Example

Info

Legende
Legend

- SP**
CBN Schneidwerkzeug aus CBN // CBN insert // Outils coupants en CBN // Inserto CBN // Inserto CBN // CBN kesici uç
- SP** Schneidwerkzeug aus Hartmetall // Carbide insert // Outils coupants en carbure de tungstène // Inserto in metallo duro
HM Inserto de carburo // Karbür kesici uç
- TW** Trägerwerkzeug aus Stahl // Steel toolholder // Porte-outils en acier // Porta inserto in acciaio
ST Porta-herramientas de acero // Çelik tutucu
- L** Links wie gezeichnet // Left hand version shown // A gauche comme présenté // In figura utensile sinistro
Versión izquierda, como se muestra // Sol model
- R** Rechts wie gezeichnet // Right hand version shown, left hand version inversely // A droite comme présenté // In figura utensile destro
Modelo derecho // Sağ model
-  Innere Kühlmittelzufuhr // Through coolant // Refroidissement interne // Lubrificazione interna
Con refrigeración interna // İçten soğutmalı
-  Nur für die Außenbearbeitung geeignet // Only suitable for external applications // Seulement pour opérations extérieures
Solo per lavorazione esterna // Soló para mecanizado externo // Dış çaplar için
-  Nur für die Innenbearbeitung geeignet // Only suitable for internal applications // Seulement pour opérations intérieures
Solo per lavorazione interna // Soló para mecanizado interno // İç çaplar için

Index

simturn E3 Produktverzeichnis
simturn E3 Product List

Artikelnr. // Part Nr.	S/P	Artikelnr. // Part Nr.	S/P	Artikelnr. // Part Nr.	S/P	Artikelnr. // Part Nr.	S/P	Artikelnr. // Part Nr.	S/P
TE3.0.500.00 L	323	TE3.0185.00 G L	329	TE3.1.000.C.00 R	326	TE3.AC08.01 MR	342	TE3.MT17.02 EM L	335
TE3.0.500.00 R	323	TE3.0185.00 G R	329	TE3.1.250.C.00 L	326	TE3.AC10.01 ML	342	TE3.MT17.02 EM R	335
TE3.0.625.00 L	323	TE3.0185.00 GT L	330	TE3.1.250.C.00 R	326	TE3.AC10.01 MR	342	TE3.MT20.01 EM L	336
TE3.0.625.00 R	323	TE3.0185.00 GT R	330	TE3.1.500.C.00 L	326	TE3.AC12.01 ML	342	TE3.MT20.01 EM R	336
TE3.0.625.90 L	324	TE3.0200.02 N L	332	TE3.1.500.C.00 R	326	TE3.AC12.01 MR	342	TE3.MT20.02 EM L	335
TE3.0.625.90 R	324	TE3.0200.02 N R	332	TE3.1105.00 F L	331	TE3.AC14.01 ML	342	TE3.MT20.02 EM R	335
TE3.0.750.00 L	323	TE3.0200.04 N L	332	TE3.1105.00 F R	331	TE3.AC14.01 MR	342	TE3.MT20.02 IM L	337
TE3.0.750.00 R	323	TE3.0200.04 N R	332	TE3.1212.00 L	323	TE3.AC16.01 ML	342	TE3.MT20.02 IM R	337
TE3.0.750.90 L	324	TE3.0200.10 V L	334	TE3.1212.00 R	323	TE3.AC16.01 MR	342	TE3.MT25.01 EM L	336
TE3.0.750.90 R	324	TE3.0200.10 V R	334	TE3.1216.00 L	323	TE3.BS11.02 ML	340	TE3.MT25.01 EM R	336
TE3.0025.A.00 L	325	TE3.0215.00 G L	329	TE3.1216.00 R	323	TE3.BS11.02 MR	340	TE3.MT25.02 EM L	335
TE3.0025.A.00 R	325	TE3.0215.00 G R	329	TE3.1216.13 L	323	TE3.BS14.02 ML	340	TE3.MT25.02 EM R	335
TE3.0025.C.00 L	326	TE3.0215.00 GT L	330	TE3.1216.13 R	323	TE3.BS14.02 MR	340	TE3.MT25.02 IM L	337
TE3.0025.C.00 R	326	TE3.0215.00 GT R	330	TE3.1306.00 F L	331	TE3.BS16.02 ML	340	TE3.MT25.02 IM R	337
TE3.0032.A.00 L	325	TE3.0220.11 V L	334	TE3.1306.00 F R	331	TE3.BS16.02 MR	340	TE3.MT30.01 EM L	336
TE3.0032.A.00 R	325	TE3.0220.11 V R	334	TE3.1607.00 F L	331	TE3.BS19.02 ML	340	TE3.MT30.01 EM R	336
TE3.0032.C.00 L	326	TE3.0223.00 J L	352	TE3.1607.00 F R	331	TE3.BS19.02 MR	340	TE3.MT30.02 EM L	335
TE3.0032.C.00 R	326	TE3.0223.00 J R	352	TE3.1608.00 F L	331	TE3.BS20.02 ML	340	TE3.MT30.02 EM R	335
TE3.0040.A.00 L	325	TE3.0238.02 N R	332	TE3.1608.00 F R	331	TE3.BS20.02 MR	340	TE3.MT30.02 IM L	337
TE3.0040.A.00 R	325	TE3.0250.02 N L	332	TE3.1609.00 F L	331	TE3.BS28.02 ML	340	TE3.MT30.02 IM R	337
TE3.0040.C.00 L	326	TE3.0250.02 N R	332	TE3.1609.00 F R	331	TE3.BS28.02 MR	340	TE3.MT35.01 EM L	336
TE3.0040.C.00 R	326	TE3.0250.02 NW L	333	TE3.1616.00 L	323	TE3.L100.06 PS L	346	TE3.MT35.01 EM R	336
TE3.0050.00 G L	329	TE3.0250.02 NW R	333	TE3.1616.00 R	323	TE3.L100.06 PT L	346	TE3.MT35.02 EM L	335
TE3.0050.00 G R	329	TE3.0250.04 N L	332	TE3.1616.13 L	323	TE3.L100.06 PV L	346	TE3.MT35.02 EM R	335
TE3.0060.00 G L	329	TE3.0250.04 N R	332	TE3.1616.13 R	323	TE3.L100.12 PS L	346	TE3.MT35.02 IM L	337
TE3.0060.00 G R	329	TE3.0250.12 V L	334	TE3.1616.90 L	324	TE3.L100.12 PT L	346	TE3.MT35.02 IM R	337
TE3.0070.00 G L	329	TE3.0250.12 V R	334	TE3.1616.90 R	324	TE3.L150.020 AG L	350	TE3.MT40.02 EM L	335
TE3.0070.00 G R	329	TE3.0265.00 G L	329	TE3.1810.00 F L	331	TE3.L150.020 AG R	351	TE3.MT40.02 EM R	335
TE3.0080.00 G L	329	TE3.0265.00 G R	329	TE3.1810.00 F R	331	TE3.L160.06 PS L	346	TE3.MT50.02 EM L	335
TE3.0080.00 G R	329	TE3.0280.14 V L	334	TE3.1812.00 F L	331	TE3.L160.06 PT L	346	TE3.MT50.02 EM R	335
TE3.0090.00 G L	329	TE3.0280.14 V R	334	TE3.1812.00 F R	331	TE3.L160.06 PV L	346	TE3.MT60.01 EM L	336
TE3.0090.00 G R	329	TE3.0300.02 N L	332	TE3.2020.00 L	323	TE3.L160.12 PT L	346	TE3.MT60.01 EM R	336
TE3.0100.00 G L	329	TE3.0300.02 N R	332	TE3.2020.00 R	323	TE3.L200.020 AG L	350	TE3.MT60.02 EM L	335
TE3.0100.00 G R	329	TE3.0300.04 N L	332	TE3.2020.13 L	323	TE3.L200.020 AG R	351	TE3.MT60.02 EM R	335
TE3.0100.005 N L	332	TE3.0300.04 N R	332	TE3.2020.13 R	323	TE3.L200.05 PS L	346	TE3.NP14.02 MR	344
TE3.0100.005 N R	332	TE3.0300.06 N L	332	TE3.2020.90 L	324	TE3.L200.05 PT L	346	TE3.NP18.02 MR	344
TE3.0100.02 N L	332	TE3.0300.06 N R	332	TE3.2020.90 R	324	TE3.L200.05 PV L	346	TE3.NP27.02 MR	344
TE3.0100.02 N R	332	TE3.0300.08 N L	332	TE3.2115.00 F L	331	TE3.L200.12 PT L	346	TE3.R100.06 PS L	347
TE3.0100.05 V L	334	TE3.0300.08 N R	332	TE3.2115.00 F R	331	TE3.L300.020 AG L	350	TE3.R100.06 PS R	345
TE3.0100.05 V R	334	TE3.0300.15 V L	334	TE3.2525.90 L	323	TE3.L300.020 AG R	351	TE3.R100.06 PT R	345
TE3.0110.00 G L	329	TE3.0300.15 V R	334	TE3.2525.90 R	323	TE3.MT05.01 EM L	336	TE3.R100.06 PV R	345
TE3.0110.00 G R	329	TE3.0315.00 G L	329	TE3.2525.15 L	323	TE3.MT05.01 EM R	336	TE3.R100.12 PS R	345
TE3.0110.00 GT L	330	TE3.0315.00 G R	329	TE3.2525.15 R	323	TE3.MT05.02 EM L	335	TE3.R100.12 PT R	345
TE3.0110.00 GT R	330	TE3.0318.02 N R	332	TE3.2525.90 L	324	TE3.MT05.02 EM R	335	TE3.R100.12 PV R	345
TE3.0110.31 G L	329	TE3.0356.00 J L	352	TE3.2525.90 R	324	TE3.MT07.02 EM L	335	TE3.R150.020 AG L	349
TE3.0110.31 G R	329	TE3.0356.00 J R	352	TE3.2616.00 F L	331	TE3.MT07.02 EM R	335	TE3.R150.020 AG R	348
TE3.0117.00 GR	329	TE3.0360.18 V L	334	TE3.2616.00 F R	331	TE3.MT08.02 EM L	335	TE3.R160.06 PS L	347
TE3.0120.06 V L	334	TE3.0360.18 V R	334	TE3.2617.00 F L	331	TE3.MT08.02 EM R	335	TE3.R160.06 PS R	345
TE3.0120.06 V R	334	TE3.0400.02 N L	332	TE3.2617.00 F R	331	TE3.MT10.01 EM L	336	TE3.R160.06 PT L	347
TE3.0130.00 G L	329	TE3.0400.02 N R	332	TE3.3118.00 F L	331	TE3.MT10.01 EM R	336	TE3.R160.06 PT R	345
TE3.0130.00 G R	329	TE3.0400.04 N L	332	TE3.3118.00 F R	331	TE3.MT10.02 EM L	335	TE3.R160.06 PV L	347
TE3.0130.00 GT L	330	TE3.0400.04 N R	332	TE3.3225.17 L	323	TE3.MT10.02 EM R	335	TE3.R160.06 PV R	345
TE3.0130.00 GT R	330	TE3.0400.20 V L	334	TE3.3225.17 R	323	TE3.MT10.02 IM L	337	TE3.R200.020 AG L	349
TE3.0150.02 N L	332	TE3.0400.20 V R	334	TE3.4120.00 F L	331	TE3.MT10.02 IM R	337	TE3.R200.020 AG R	348
TE3.0150.02 N R	332	TE3.0415.00 G L	329	TE3.4120.00 F R	331	TE3.MT12.01 EM L	336	TE3.R200.05 PS L	347
TE3.0150.07 V L	334	TE3.0415.00 G R	329	TE3.4125.00 F L	331	TE3.MT12.01 EM R	336	TE3.R200.05 PS R	345
TE3.0150.07 V R	334	TE3.0470.00 J L	352	TE3.4125.00 F R	331	TE3.MT12.02 EM L	335	TE3.R200.05 PT L	347
TE3.0157.079 VR	334	TE3.0470.00 J R	352	TE3.5130.00 F L	331	TE3.MT12.02 EM R	335	TE3.R200.05 PT R	345
TE3.0160.00 G L	329	TE3.0515.00 G L	329	TE3.5130.00 F R	331	TE3.MT15.01 EM L	336	TE3.R200.05 PV L	347
TE3.0160.00 G R	329	TE3.0515.00 G R	329	TE3.AC04.01 ML	342	TE3.MT15.01 EM R	336	TE3.R200.05 PV R	345
TE3.0160.00 GT L	330	TE3.0515.00 GT R	329	TE3.AC04.01 MR	342	TE3.MT15.02 EM L	335	TE3.R200.12 PS R	345
TE3.0160.00 GT R	330	TE3.1.000.00 L	323	TE3.AC05.01 ML	342	TE3.MT15.02 EM R	335	TE3.R200.020 AG L	349
TE3.0160.08 V L	334	TE3.1.000.00 R	323	TE3.AC05.01 MR	342	TE3.MT15.02 IM L	337	TE3.R300.020 AG R	348
TE3.0160.08 V R	334	TE3.1.000.90 L	324	TE3.AC06.01 ML	342	TE3.MT15.02 IM R	337	TE3.SA04.01 ML	343
TE3.0180.09 V L	334	TE3.1.000.90 R	324	TE3.AC06.01 MR	342	TE3.MT17.01 EM L	336	TE3.SA04.01 MR	343
TE3.0180.09 V R	334	TE3.1.000.C.00 L	326	TE3.AC08.01 ML	342	TE3.MT17.01 EM R	336	TE3.SA05.01 ML	343

simturn AX

simturn DX

simturn PX

simturn H2

simturn K2

simturn C4

simturn GX

simturn E3

simturn E12

simturn FX

simturn Decolletage

simturn OA

Index

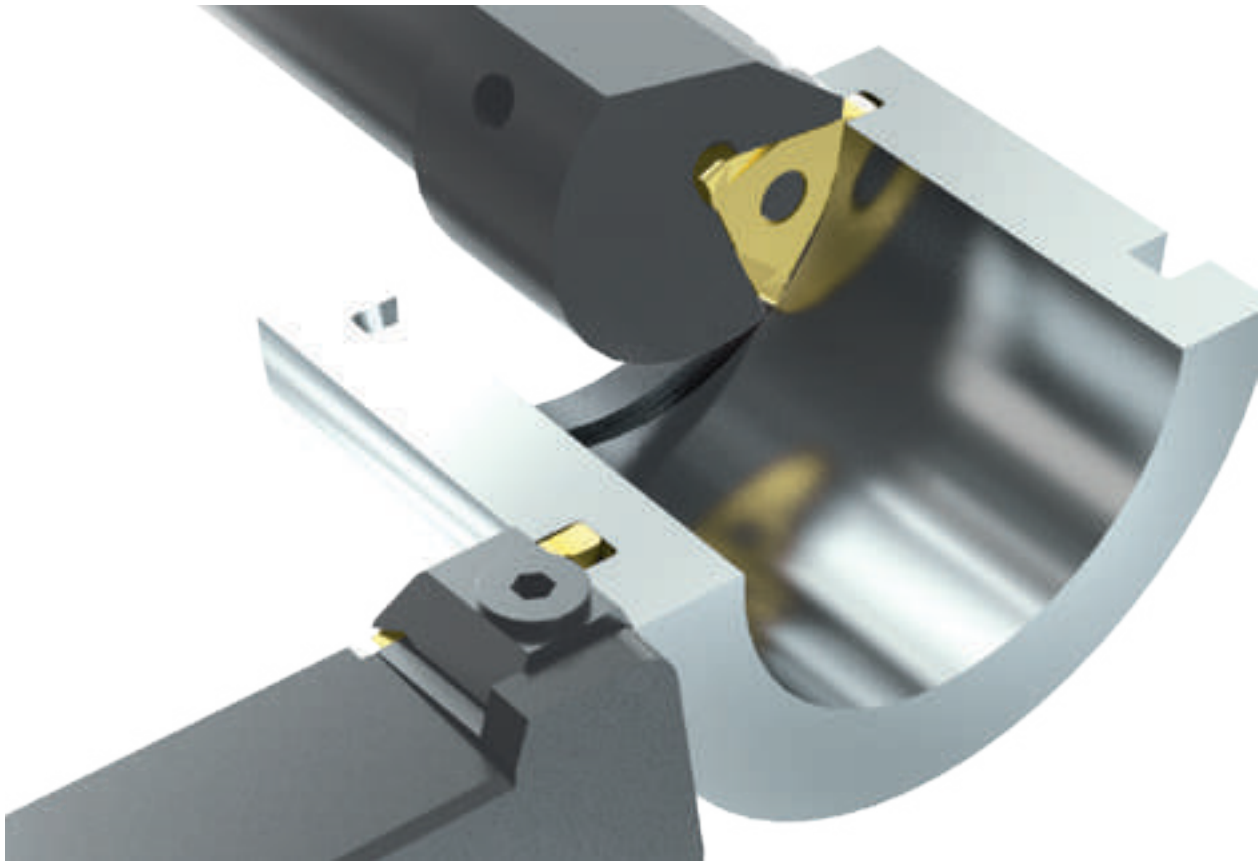
Index

simturn E3 Produktverzeichnis
simturn E3 Product List

Artikelnr. // Part Nr.	S/P
TE3.SA06.01 ML	343
TE3.SA06.01 MR	343
TE3.SA08.01 ML	343
TE3.SA08.01 MR	343
TE3.SA10.01 ML	343
TE3.SA10.01 MR	343
TE3.SA12.01 ML	343
TE3.SA12.01 MR	343
TE3.SA14.01 ML	343
TE3.SA14.01 MR	343
TE3.SA16.01 ML	343
TE3.SA16.01 MR	343
TE3.TR15.02 M L	341
TE3.TR15.02 M R	341
TE3.TR20.02 M L	341
TE3.TR20.02 M R	341
TE3.TR30.02 M L	341
TE3.TR30.02 M R	341
TE3.TR40.02 M L	341
TE3.TR40.02 M R	341
TE3.TR50.02 M L	341
TE3.TR50.02 M R	341
TE3.TR60.02 M L	341
TE3.TR60.02 M R	341
TE3.UN08.02 EM R	338
TE3.UN08.02 IM R	339
TE3.UN09.02 EM R	338
TE3.UN09.02 IM R	339
TE3.UN10.02 EM R	338
TE3.UN10.02 IM R	339
TE3.UN11.02 EM R	338
TE3.UN11.02 IM R	339
TE3.UN12.02 EM R	338
TE3.UN12.02 IM R	339
TE3.UN14.02 EM R	338
TE3.UN16.02 EM R	338
TE3.UN18.02 EM R	338
TE3.UN20.02 EM R	338
TE3.UN24.02 EM R	338
TE3.UN28.02 EM R	338
TE3.UN32.02 EM R	338
TOA.TE3.51.C.19.05 L	327
TOA.TE3.51.C.19.05 R	327
TOA.TE3.51.C.29.05 L	327
TOA.TE3.51.C.29.05 R	327
TOG.K.TE3.A1 L	328
TOG.K.TE3.A1 R	328
TOG.K.TE3.B1 L	328
TOG.K.TE3.B1 R	328

Das Werkzeugsystem im Überblick The Tool System Overview

Sehr weit verbreitetes Stechsystem.
Wide-spread grooving system.



Werkzeugsystem bestehend aus dreischneidiger Hartmetall-Wendeschneidplatte und einer Auswahl an Stahl-Trägerwerkzeugen.

Mögliche Stechtiefen bis 8,0 mm bei der Außenbearbeitung. Verschiedene geschliffene Spanformgeometrien verfügbar.

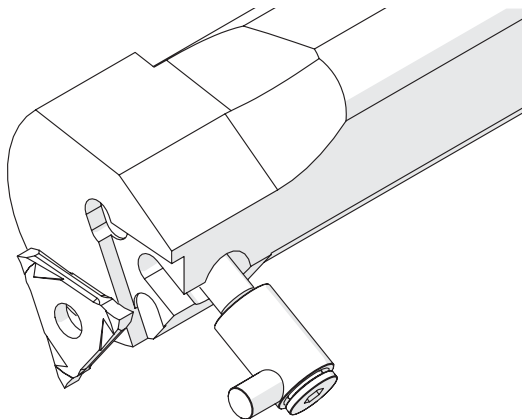
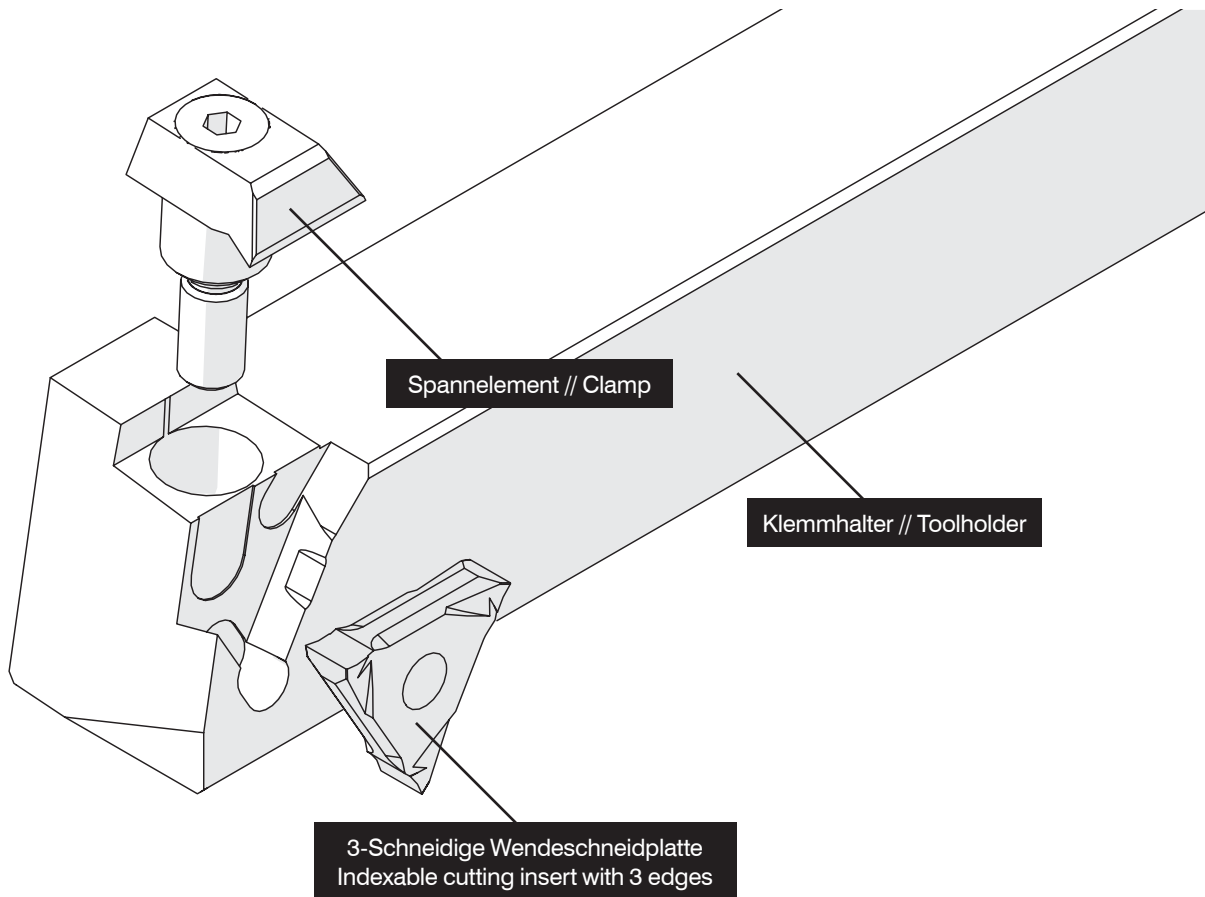
Tool system of triple-edged indexable carbide cutting insert and steel toolholders.

Possible depth of cut up to 8,0 mm for external applications. Range of ground cutting edge geometries available.

Das System im Detail The System Details

Bitte beachten Sie die allgemeinen Gebrauchshinweise auf Seite
 Please read the general instructions for use on page

433



**Verfügbar für die Innen- und Außenbearbeitung
 Available for internal and external applications**

Außen // External

Maximale Stechtiefe 8,0 mm

Maximum cutting depth 8,0 mm

Innen // Internal

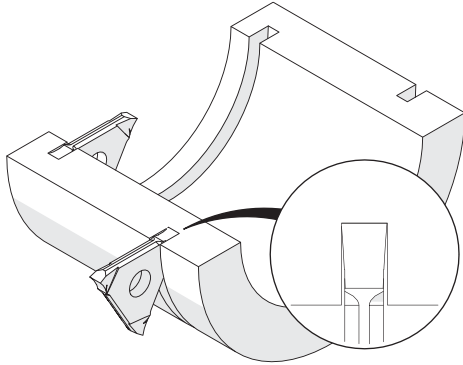
Ab Bohrungsdurchmesser 46,0 mm

As of bore diameter 46,0 mm

Standardanwendungen Standard Applications

Ab Seite
 As of page

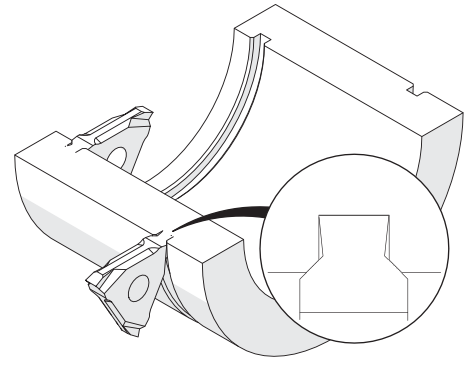
369



Stechdrehen, Sicherungsringnuten
 Grooving, Circlip Ring Grooves

Ab Seite
 As of page

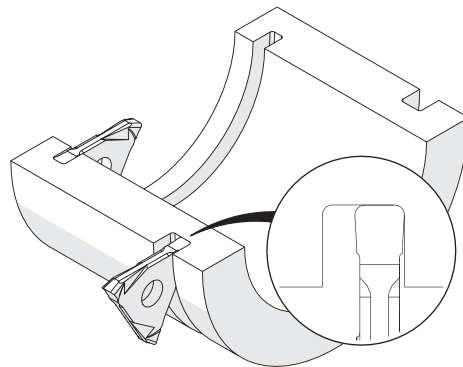
376



Stechdrehen, Sicherungsringnuten mit Fassung
 Grooving, Circlip Ring Grooves with Chamfer

Ab Seite
 As of page

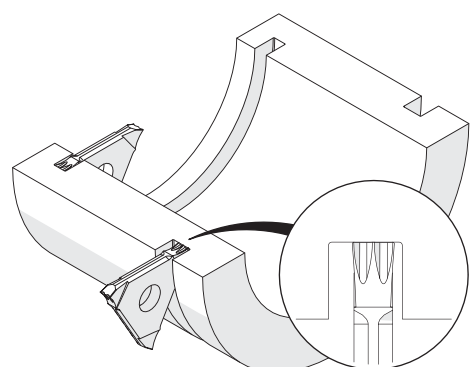
378



Einstecken und Profildrehen
 Grooving and Profiling

Seite
 Page

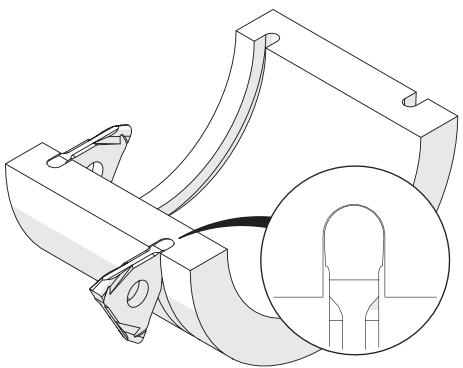
380



Stech- und Längsdrehen
 Grooving and Turning

Seite
 Page

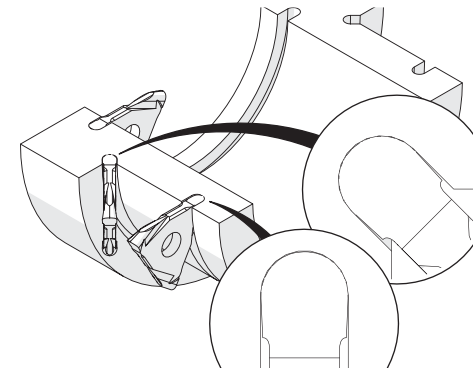
381



Einstecken und Profildrehen, Vollradius
 Grooving and Profiling, Full Radius

Seite
 Page

382

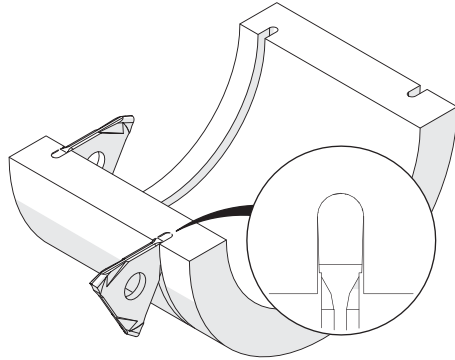


Eckenfreistiche, Einstecken und
 Profildrehen, Vollradius
 Corner Reliefs, Grooving and Profiling,
 Full Radius

Standardanwendungen Standard Applications

Ab Seite
 As of page

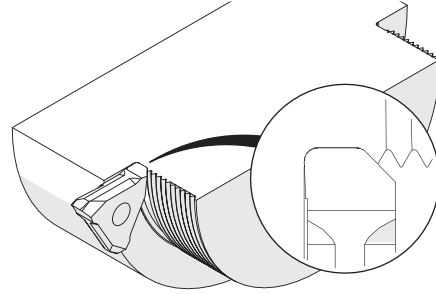
383



Stechdrehen, Runddrahtsprengringe
 Grooving, Round-Wire Snap-Ring

Ab Seite
 As of page

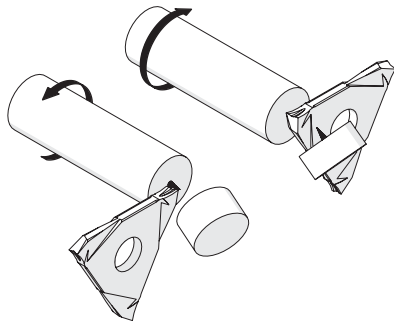
385



Gewindefreistriche
 Thread Reliefs

Seite
 Page

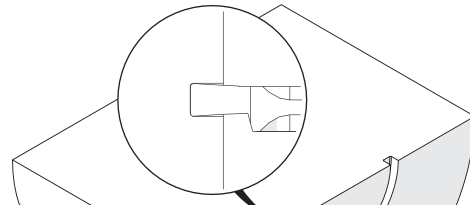
386



Abstechen
 Parting off

Seite
 Page

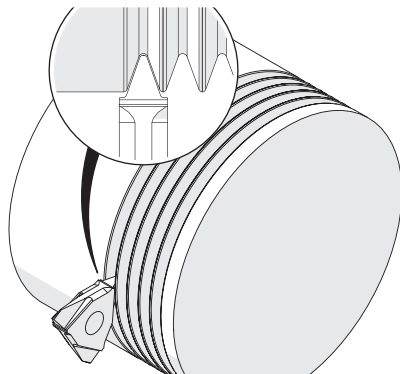
387



Axialstechen
 Face Grooving

Seite
 Page

388



Poly-V-Riemennuten
 Poly-V-Belt-Grooves

Klemmhalter, Außenbearbeitung

Trägerschaft für die Außenbearbeitung.

Toolholder, External Applications

Toolholder for external applications.

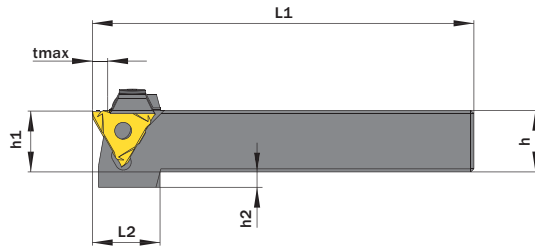
Anzugsmoment (Schraube) // Tightening torque (screw)

6,0 Nm



Legende
Legend **389**

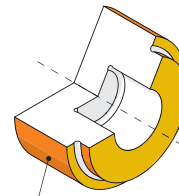
Scan QR-Code Oder besuchen Sie // Or Visit
www.simtek.info/cp/487



Maße f und w in Abhängigkeit der Schneidplatte
Measures f and w depend on cutting insert

Abbildung zeigt / Drawing shows: E60.2020.04 R

tmax in Abhängigkeit vom
Werkstückdurchmesser (Ød)
tmax depends on
workpiece diameter (Ød) tmax
≤ Ø40,0 mm / ≤ Ø1.5748" 6,0 mm / 0.2362"
> Ø40,0 mm / > Ø1.5748" 4,0 mm / 0.1575"



- Hauptsächlich geeignet für diese Flächen
Mainly designed for these surfaces
- Je nach Schneidplatte/Aufnahme ebenfalls möglich
Also possible depending on insert/fixation type

h	b	Artikelnummer Part number	Webcode www.simtek.com/webcode	f1	h1 ^{js14}	h2	L1	L2	tmax	w ≥	w ≤	Spannelement Clamp	Connectcode www.simtek.com/code
mm	mm			mm	mm	mm	mm	mm	mm	mm	mm		
▼ h = 12,0 mm													
12,0	12,0	E60.1212.01 R/L	R AFXZ L AG4T	10,5	12,0	13,0	100,0	24,0	4,0	0,5	2,0	E12.1.3	E12.A1
12,0	12,0	E60.1212.23 R/L	R ACFC L ADF8	10,0	12,0	13,0	100,0	24,0	6,0	1,0	2,5	E12.1.3	E12.A2
12,0	12,0	E60.1212.02 R/L	R AD5Ø L AAPU	9,5	12,0	13,0	100,0	24,0	6,0	2,0	3,0	E12.1.3	E12.B2
12,0	12,0	E60.1212.03 R/L	R ABS4 L AG3U	8,5	12,0	13,0	100,0	24,0	6,0	3,0	4,0	E12.1.3	E12.C3
▼ h = 12,7 mm													
12,7	12,7	E60.0.500.01 R/L	R AWCU L AWCA	14,5	16,0	9,0	125,0	22,0	4,0	0,5	2,0	E16.1.4	E12.A1
12,7	12,7	E60.0.500.02 R/L	R AEVD L AGVD	13,5	16,0	9,0	125,0	22,0	6,0	2,0	3,0	E16.1.4	E12.B2
12,7	12,7	E60.0.500.03 R/L	R AC8N L AEUW	12,5	16,0	9,0	125,0	22,0	6,0	3,0	4,0	E16.1.4	E12.C3
12,7	12,7	E60.0.500.23 R/L	R AA63 L AJYE	14,0	16,0	9,0	125,0	22,0	6,0	1,0	2,5	E16.1.4	E12.A2
▼ h = 16,0 mm													
16,0	16,0	E60.1616.01 R/L	R ABB3 L AAY4	14,5	16,0	9,0	125,0	22,0	4,0	0,5	2,0	E16.1.4	E12.A1
16,0	16,0	E60.1616.23 R/L	R AE9Q L AM6Z	14,0	16,0	9,0	125,0	22,0	6,0	1,0	2,5	E16.1.4	E12.A2
16,0	16,0	E60.1616.02 R/L	R AEHG L AAE1	13,5	16,0	9,0	125,0	22,0	6,0	2,0	3,0	E16.1.4	E12.B2
16,0	16,0	E60.1616.03 R/L	R AE36 L AGDN	12,5	16,0	9,0	125,0	22,0	6,0	3,0	4,0	E16.1.4	E12.C3
16,0	16,0	E60.1616.04 R/L	R AFØS L AHTØ	11,5	16,0	9,0	125,0	22,0	6,0	4,0	6,3	E16.1.4	E12.D4
▼ h = 20,0 mm													
20,0	20,0	E60.2020.01 R/L	R ADXD L AG3J	18,5	20,0	5,0	125,0	21,0	4,0	0,5	2,0	E20.1.4	E12.A1
20,0	20,0	E60.2020.23 R/L	R AMQ8 L AM2P	18,0	20,0	5,0	125,0	21,0	6,0	1,0	2,5	E20.1.4	E12.A2
20,0	20,0	E60.2020.02 R/L	R APY1 L APX5	17,5	20,0	5,0	125,0	21,0	6,0	2,0	3,0	E20.1.4	E12.B2
20,0	20,0	E60.2020.03 R/L	R APWN L ANGÇ	16,5	20,0	5,0	125,0	21,0	6,0	3,0	4,0	E20.1.4	E12.C3
20,0	20,0	E60.2020.04 R/L	R AH26 L AAWF	14,8	20,0	5,0	125,0	21,0	6,0	4,0	6,3	E20.1.4	E12.D4

Verwandte Werkzeuge finden Sie auch auf der folgenden Seite!
Related Items can be found on the following page as well!

Fortgesetzte Tabelle
Continued Table

Bestellbeispiel // Order example: **E60.2020.01 R** (R = Rechte Ausführung // Right hand version)

Ersatzschraube // Spare screw: E M6x25 SW3

Klemmhalter, Außenbearbeitung

Trägerschaft für die Außenbearbeitung.

Toolholder, External Applications

Toolholder for external applications.

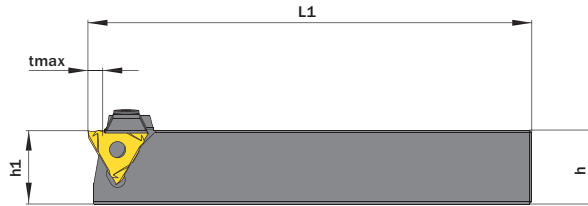
Anzugsmoment (Schraube) // Tightening torque (screw)

6,0 Nm



TW ST R Legende Legend **389**

Scan QR-Code Oder besuchen Sie // Or Visit www.simtek.info/cp/863

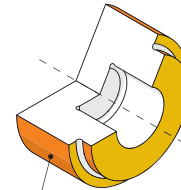


tmax in Abhängigkeit vom Werkstückdurchmesser (Ød)
 tmax depends on workpiece diameter (Ød)

≤ Ø40,0 mm / ≤ Ø1.5748"	tmax
6,0 mm / 0.2362"	
> Ø40,0 mm / > Ø1.5748"	4,0 mm / 0.1575"



Maße f und w in Abhängigkeit der Schneidplatte
 Measures f and w depend on cutting insert



- Hauptsächlich geeignet für diese Flächen
 Mainly designed for these surfaces
- Je nach Schneidplatte/Aufnahme ebenfalls möglich
 Also possible depending on insert/fixation type

Abbildung zeigt / Drawing shows: E60.2525.04 R

h	b	Artikelnummer Part number	Webcode www.simtek.com/webcode	f1	h1 ^{is14}	L1	tmax	w ≥	w ≤	Spannelement Clamp	Connectcode www.simtek.com/ccode
mm	mm			mm	mm	mm	mm	mm	mm		

◀ Fortgesetzte Tabelle Continued Table **Verwandte Werkzeuge finden Sie auch auf der vorhergehenden Seite!**
 Related items can be found on the previous page as well!

▼ h = 25,0 mm												
25,0	25,0	E60.2525.01 R/L	R AA2H L ADW8	23,5	25,0	150,0	4,0	0,5	2,0	E20.1.4	E12.A1	
25,0	25,0	E60.2525.23 R/L	R AGZ9 L AMA6	23,1	25,0	150,0	6,0	1,0	2,5	E20.1.4	E12.A2	
25,0	25,0	E60.2525.02 R/L	R AG39 L AEV0	22,5	25,0	150,0	6,0	2,0	3,0	E20.1.4	E12.B2	
25,0	25,0	E60.2525.03 R/L	R AD97 L APFP	21,5	25,0	150,0	6,0	3,0	4,0	E20.1.4	E12.C3	
25,0	25,0	E60.2525.04 R/L	R APYG L ABNF	19,8	25,0	150,0	6,0	4,0	6,3	E20.1.4	E12.D4	
▼ h = 32,0 mm												
32,0	32,0	E60.3232.01 R/L	R AD0M L APH0	30,5	32,0	170,0	4,0	0,5	2,0	E20.1.4	E12.A1	
32,0	32,0	E60.3232.02 R/L	R AMKM L AD7B	29,5	32,0	170,0	6,0	2,0	3,0	E20.1.4	E12.B2	
32,0	32,0	E60.3232.03 R/L	R AHJQ L AAXU	28,5	32,0	170,0	6,0	3,0	4,0	E20.1.4	E12.C3	
32,0	32,0	E60.3232.04 R/L	R AA5F L AN3K	26,8	32,0	170,0	6,0	4,0	6,3	E20.1.4	E12.D4	

■ Bestellbeispiel // Order example: **E60.2525.01 R** (R = Rechte Ausführung // Right hand version)

■ Ersatzschraube // Spare screw: E M6x25 SW3

Klemmhalter, Außenbearbeitung

Trägerschaft für die Außenbearbeitung.

Toolholder, External Applications

Toolholder for external applications.

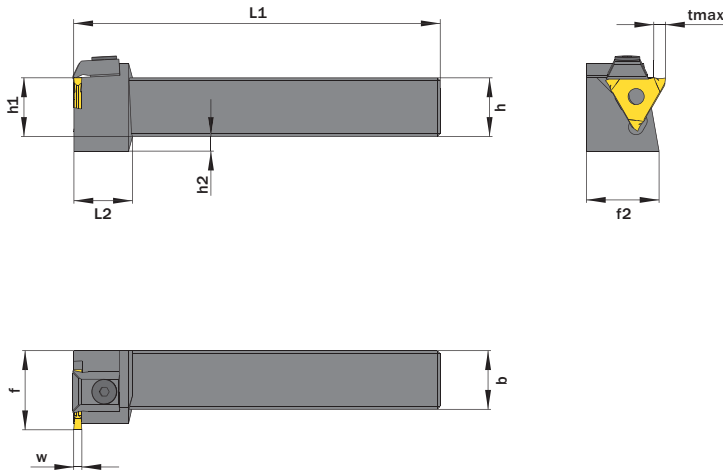
Anzugsmoment (Schraube) // Tightening torque (screw)

6,0 Nm

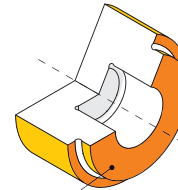


Legende
 Legend **389**

Scan QR-Code Oder besuchen Sie // Or Visit
www.simtek.info/cp/492



tmax in Abhängigkeit vom Werkstückdurchmesser (Ød)	
tmax depends on workpiece diameter (Ød)	
≤ Ø40,0 mm / ≤ Ø1.5748"	tmax 4,0 mm / 0.1575"
> Ø40,0 mm / > Ø1.5748"	tmax 6,0 mm / 0.2362"



- Hauptsächlich geeignet für diese Flächen
 Mainly designed for these surfaces
- Je nach Aufnahmetyp ebenfalls möglich
 Also possible depending on fixation type

Abbildung zeigt / Drawing shows: E69.2020.03 R

h	b	Artikelnummer Part number	Webcode www.simtek.com/webcode	f	f2	h1 ^{js14}	h2	L1	L2	tmax	w ≥	w ≤	Spannelement Clamp	Connectcode www.simtek.com/code
mm	mm			mm	mm	mm	mm	mm	mm	mm	mm	mm		
▼ h = 20,0 mm														
20,0	20,0	E69.2020.01 R/L	R ANHQ L AATF	27,0	24,5	20,0	5,0	125,0	20,0	4,0	0,5	2,0	E20.1-4	E12.A1
20,0	20,0	E69.2020.02 R/L	R APFK L AGGY	27,0	24,5	20,0	5,0	125,0	20,0	6,0	2,0	3,0	E20.1-4	E12.B2
20,0	20,0	E69.2020.03 R/L	R AKW8 L AH05	27,0	24,5	20,0	5,0	125,0	20,0	6,0	3,0	4,0	E20.1-4	E12.C3
20,0	20,0	E69.2020.04 R/L	R AM7V L AFFX	27,0	24,5	20,0	5,0	125,0	20,0	6,0	4,0	6,3	E20.1-4	E12.D4
▼ h = 25,0 mm														
25,0	25,0	E69.2525.01 R/L	R AJCG L AE5D	32,0	29,5	25,0	-	150,0	-	4,0	0,5	2,0	E20.1-4	E12.A1
25,0	25,0	E69.2525.02 R/L	R ADXZ L AAUK	32,0	29,5	25,0	-	150,0	-	6,0	2,0	3,0	E20.1-4	E12.B2
25,0	25,0	E69.2525.03 R/L	R AE5X L AD8H	32,0	29,5	25,0	-	150,0	-	6,0	3,0	4,0	E20.1-4	E12.C3
25,0	25,0	E69.2525.04 R/L	R AG37 L AFHN	32,0	29,5	25,0	-	150,0	-	6,0	4,0	6,3	E20.1-4	E12.D4

Bestellbeispiel // Order example: **E69.2020.02 R** (R = Rechte Ausführung // Right hand version)

Ersatzschraube // Spare screw: E M6x25 SW3

simturn AX
 simturn DX
 simturn PX
 simturn H2
 simturn K2
 simturn C4
 simturn GX
 simturn E3
 simturn E12
 simturn FX
 simturn Decolletage
 simturn OA
 Index

Klemmhalter, Innenbearbeitung

Trägerschaft für die Innenbearbeitung.

Toolholder, Internal Applications

Toolholder for internal applications.

Anzugsmoment (Schraube) // Tightening torque (screw)

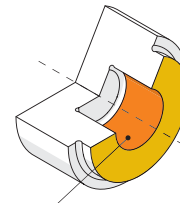
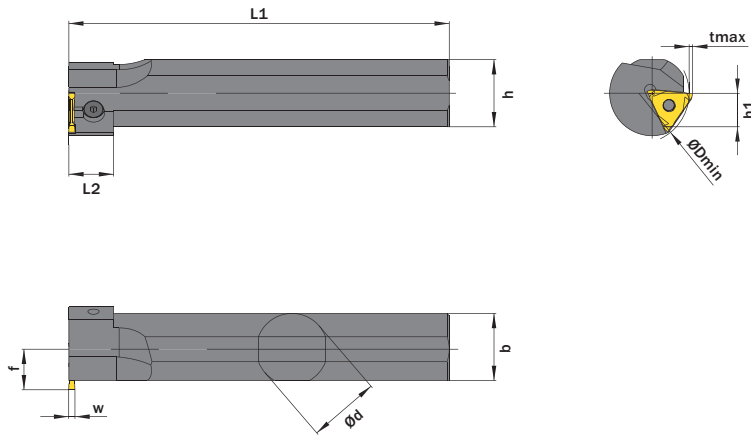
6,0 Nm



Legende
 Legend **389**

Scan QR-Code Oder besuchen Sie // Or Visit www.simtek.info/cp/493

Bohrungsdurchmesser (ØDmin) Bore diameter (ØDmin)	tmax
Ø46 mm / Ø1.8110"	2,0 mm / 0.0787"
Ø50 mm / Ø1.9685"	3,0 mm / 0.1181"
Ø60 mm / Ø2.3622"	4,0 mm / 0.1575"
Ø100 mm / Ø3.9370"	5,0 mm / 0.1969"



- Hauptsächlich geeignet für diese Flächen
Mainly designed for these surfaces
- Je nach Schneidplatte ebenfalls möglich
Also possible depending on insert type

Abbildung zeigt / Drawing shows: E30.0032.02 R

Ød ^{g6} mm	Artikelnummer Part number	Webcode www.simtek.com/webcode	b mm	ØDmin (Min. Bohrung) ØDmin (min. bore) mm	f mm	h mm	h1 ^{js14} mm	L1 mm	L2 mm	w ≥ mm	w ≤ mm	Spannelement Clamp	Connectcode www.simtek.com/code
▼ Ød = 25,0 mm													
25,0	E30.0025.01 R/L	R ADSN L AP39	25,0	46,0	19,0	23,0	11,5	170,0	20,0	0,5	2,0	E30.14	E12.A1
25,0	E30.0025.02 R/L	R ACMØ L AE7B	25,0	46,0	19,0	23,0	11,5	170,0	20,0	2,0	3,0	E30.14	E12.B2
25,0	E30.0025.03 R/L	R AHB6 L AHFE	25,0	46,0	19,0	23,0	11,5	170,0	20,0	3,0	4,0	E30.14	E12.C3
25,0	E30.0025.04 R/L	R AADX L Anew	25,0	46,0	19,0	23,0	11,5	170,0	20,0	4,0	6,3	E30.14	E12.D4
▼ Ød = 32,0 mm													
32,0	E30.0032.01 R/L	R AH4Z L AGQB	30,0	46,0	20,0	30,0	15,0	200,0	20,0	0,5	2,0	E30.14	E12.A1
32,0	E30.0032.02 R/L	R AK56 L AC57	30,0	46,0	20,0	30,0	15,0	200,0	20,0	2,0	3,0	E30.14	E12.B2
32,0	E30.0032.03 R/L	R ADSM L AFS6	30,0	46,0	20,0	30,0	15,0	200,0	20,0	3,0	4,0	E30.14	E12.C3
32,0	E30.0032.04 R/L	R ACSM L ACYE	30,0	46,0	20,0	30,0	15,0	200,0	20,0	4,0	6,3	E30.14	E12.D4
▼ Ød = 40,0 mm													
40,0	E30.0040.01 R/L	R AGEG L AD3H	38,0	46,0	24,0	38,0	19,0	250,0	-	0,5	2,0	E30.14	E12.A1
40,0	E30.0040.02 R/L	R AJ7U L AEP5	38,0	46,0	24,0	38,0	19,0	250,0	-	2,0	3,0	E30.14	E12.B2
40,0	E30.0040.03 R/L	R AEKC L ADT8	38,0	46,0	24,0	38,0	19,0	250,0	-	3,0	4,0	E30.14	E12.C3
40,0	E30.0040.04 R/L	R ACM3 L AJ7G	38,0	46,0	24,0	38,0	19,0	250,0	-	4,0	6,3	E30.14	E12.D4

Bestellbeispiel // Order example: **E30.0025.01 R** (R = Rechte Ausführung // Right hand version)

Ersatzschraube // Spare screw: E M6x25 SW3

Klemmhalter, Außenbearb., Eckenfreistriche

Trägerschaft für Eckenfreistriche, außen.

Toolholder, External, Corner Reliefs

Toolholder for external corner reliefs.

Anzugsmoment (Schraube) // Tightening torque (screw)

6,0 Nm



TW
ST

R

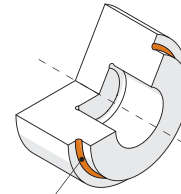
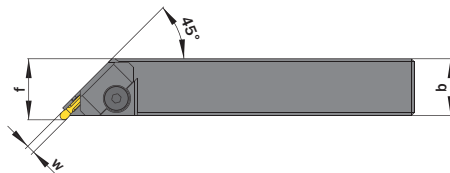
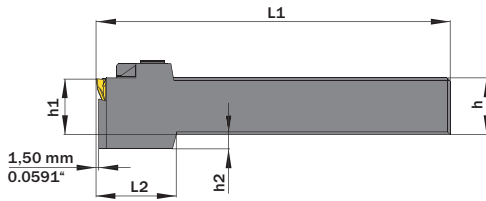
Legende
Legend

389



Scan
QR-Code

Oder besuchen Sie // Or Visit
www.simtek.info/cp/491



■ **Hauptsächlich geeignet für diese Flächen**
 Mainly designed for these surfaces

Abbildung zeigt / Drawing shows: E09.2020.03 R

h	b	Artikelnummer Part number	Webcode www.simtek.com/webcode	f	h1 ^{js14}	h2	L1	L2	w ≥	w ≤	Spannelement Clamp	Connectcode www.simtek.com/ccode
mm	mm			mm	mm	mm	mm	mm	mm	mm		
▼ h = 20,0 mm												
20,0	20,0	E09.2020.02 R/L	R AD3B L AB9H	21,5	20,0	5,0	125,0	30,0	1,9	3,0	E09.1.4	E12.A2 E12.B2
20,0	20,0	E09.2020.03 R/L	R AC9H L APDV	21,5	20,0	5,0	125,0	30,0	3,0	4,0	E09.1.4	E12.C3
20,0	20,0	E09.2020.04 R/L	R AK9N L AE7D	21,5	20,0	5,0	125,0	30,0	4,0	6,3	E09.1.4	E12.D4
▼ h = 25,0 mm												
25,0	25,0	E09.2525.02 R/L	R AEZA L ADD1	26,5	25,0	-	150,0	-	1,9	3,0	E09.1.4	E12.A2 E12.B2
25,0	25,0	E09.2525.03 R/L	R AFYU L ABUY	26,5	25,0	-	150,0	-	3,0	4,0	E09.1.4	E12.C3
25,0	25,0	E09.2525.04 R/L	R AJCA L AN1F	26,5	25,0	-	150,0	-	4,0	6,3	E09.1.4	E12.D4
▼ h = 32,0 mm												
32,0	32,0	E09.3232.02 R/L	R AD3N L AMD5	33,5	32,0	-	170,0	-	1,9	3,0	E09.1.4	E12.A2 E12.B2
32,0	32,0	E09.3232.03 R/L	R AJ6X L APZS	33,5	32,0	-	170,0	-	3,0	4,0	E09.1.4	E12.C3
32,0	32,0	E09.3232.04 R/L	R AP4P L APG0	33,5	32,0	-	170,0	-	4,0	6,3	E09.1.4	E12.D4

■ Bestellbeispiel // Order example: **E09.2020.02 R** (R = Rechte Ausführung // Right hand version)

■ Ersatzschraube // Spare screw: E M6x25 SW3

simturn AX

simturn DX

simturn PX

simturn H2

simturn K2

simturn C4

simturn GX

simturn E3

simturn E12

simturn FX

simturn Decolletage

simturn OA

Index

Klemmhalter, Außenbearbeitung

Ideal für Traub-Doppelspindelmaschinen (bspw. TNL12).

Toolholder, External Applications

First choice for Traub double spindle machines (e.g. TNL12).

Anzugsmoment (Schraube) // Tightening torque (screw)

4,5 Nm



TW
ST

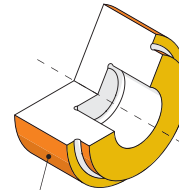
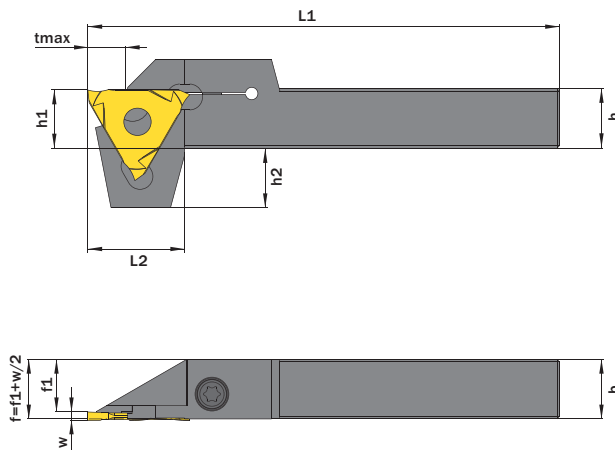
R

Legende
 Legend **389**



Scan
 QR-Code

Oder besuchen Sie // Or Visit
www.simtek.info/cp/1005



- Hauptsächlich geeignet für diese Flächen
 Mainly designed for these surfaces
- Je nach Schneidplatte/Aufnahme ebenfalls möglich
 Also possible depending on insert/fixation type

Abbildung zeigt / Drawing shows: E68.1212.08 R

h	b	Artikelnummer Part number	Webcode www.simtek.com/webcode	f1	h1 ^{is14}	h2	L1	L2	tmax	w ≥	w ≤	Schraube Screw	Schraubenschlüssel Screw driver	Connectcode www.simtek.com/code
mm	mm			mm	mm	mm	mm	mm	mm	mm	mm			
▼ h = 12,0 mm														
12,0	12,0	E68.1212.08 R/L	R AGVQ L APZ7	11,0	12,0	12,0	95,0	19,5	8,0	0,5	1,5	E M4x12T15F	T15F	E68.A1
12,0	12,0	E68.1212.11 R/L	R AHGA L ACTS	10,7	12,0	12,0	95,0	19,5	8,0	1,0	2,0	E M4x12T15F	T15F	E68.A1
▼ h = 16,0 mm														
16,0	16,0	E68.1616.11 R/L	R AE95 L AJXG	14,7	16,0	16,0	95,0	19,5	8,0	0,5	2,0	E M4x12T15F	T15F	E68.A1

Bestellbeispiel // Order example: **E68.1212.11 R** (R = Rechte Ausführung // Right hand version)

Kassette für Modulares Werkzeugsystem TOA

Geeignet für SIMTEK Grundhalter mit Polygonschaft nach ISO 26623.

Cassette for Modular Tool System TOA

For use on SIMTEK base toolholder with polygon shank according to ISO 26623.

Anzugsmoment (Schraube) // Tightening torque (screw)

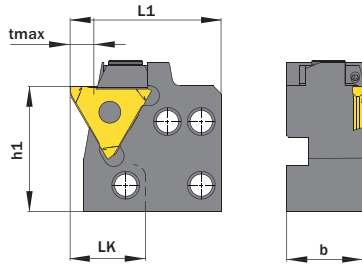
6,0 Nm



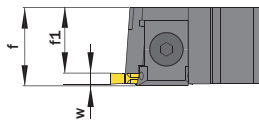
TW
ST
R

Legende
 Legend **389**

Scan QR-Code Oder besuchen Sie // Or Visit
www.simtek.info/cp/1180

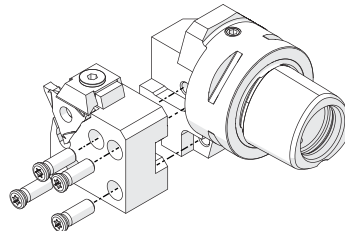


tmax in Abhängigkeit vom Werkstückdurchmesser (Ød)
 tmax depends on workpiece diameter (Ød) tmax
 < Ø40,0 mm / ≤ Ø1.5748" 6,0 mm / 0.2362"

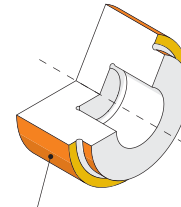


Maße f und w in Abhängigkeit der Schneidplatte
 Measures f and w depend on cutting insert

Abbildung zeigt / Drawing shows: TOA.E60.19.02 R



Schrauben für Kassettenbefestigung
 Screw for cassette mounting
T M5x15 T20R



■ Hauptsächlich geeignet für diese Flächen
 Mainly designed for these surfaces
 ■ Je nach Schneidplatte/Aufnahme ebenfalls möglich
 Also possible depending on insert/fixation type

Grundhalter finden Sie ab Seite 425
 Base toolholder can be found on page 425

w ≥	w ≤	Artikelnummer Part number	Webcode www.simtek.com/webcode	b	f1	h1	LK	L1	tmax	Spannelement Clamp	Connectcode www.simtek.com/code	Adaptcode Adaptcode
mm	mm			mm	mm	mm	mm	mm	mm			
▼ Connectcode = E12.A1												
0,5	2,0	TOA.E60.19.01 R/L	R AY99 L AY98	19,2	17,7	31,6	19,0	37,9	6,0	E16.1-4 ICR/L	E12.A1	TOA
▼ Connectcode = E12.A2												
1,0	2,5	TOA.E60.19.23 R/L	R AZAF L AZAE	19,2	17,2	31,6	19,0	37,9	6,0	E16.1-4 ICR/L	E12.A2	TOA
▼ Connectcode = E12.B2												
2,0	3,0	TOA.E60.19.02 R/L	R AZAB L AZAA	19,2	16,7	31,6	19,0	37,9	6,0	E16.1-4 ICR/L	E12.B2	TOA
▼ Connectcode = E12.C3												
3,0	4,0	TOA.E60.19.03 R/L	R AZAD L AZAC	19,2	15,7	31,6	19,0	37,9	6,0	E16.1-4 ICR/L	E12.C3	TOA
▼ Connectcode = E12.D4												
4,0	6,3	TOA.E60.19.04 R/L	R A08W L A08X	19,2	14,0	31,6	19,0	37,9	6,0	E16.1-4 ICR/L	E12.D4	TOA

Bestellbeispiel // Order example: **TOA.E60.19.23 R** (R = Rechte Ausführung // Right hand version)

simturn AX
 simturn DX
 simturn PX
 simturn H2
 simturn K2
 simturn C4
 simturn GX
 simturn E3
 simturn E12
 simturn FX
 simturn Decolletage
 simturn OA
 Index

Drehbearbeitung, vorwiegend außen // Mainly External Grooving and Turning
 simturn E12 > Trägerwerkzeug // Toolholder

simturnE12
 SIMTEK small part machining type E12

Höhenverstellbare Kassette, für Rückseitenbearbeitungen

Kassette für höhenverstellbare Rückseitenbearbeitung auf Grundhaltern-Typ „TOG“ der Marke precium.

Height-Adjustable Cassette for Back Operations

Cassette for height-adjustable back operations tools. Compatible to TOG-system by precium.



TW Legende
ST Legend

389



Scan QR-Code

Oder besuchen Sie // Or Visit www.simtek.info/cp/977

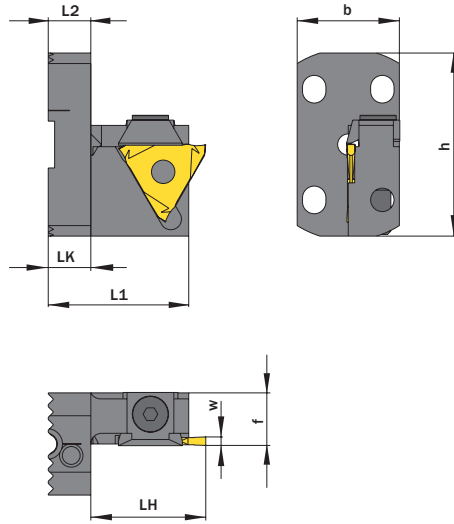


Abbildung zeigt / Drawing shows: TOG.K.E12.C1.01 R

Mehr Informationen unter www.precium.de
 More information on www.precium.de



Abbildung ähnlich // Illustration only

w	Artikelnummer Part number	Webcode www.simtek.com/webcode	b	h	f	L1	L2	LK	LH	Spannelement Clamp	Connectcode www.simtek.com/code
mm			mm	mm	mm	mm	mm	mm	mm		
1,5	TOG.K.E12.C1.01 R	AT3W	24,0	43,0	12,35	33,0	10,0	10,0	27,0	E12.1-3	E12.A1

Bestellbeispiel // Order example: **TOG.K.E12.C1.01 R** (R = Rechte Ausführung // Right hand version)

Ersatzschraube // Spare screw: E M6x25 SW3

Stechen, schmale Sicherungsringnuten, reduzierte Stechtiefe

Sicherungsringnuten, vgl. DIN 471/472 sowie DIN 983/984.
Reduzierte Stechtiefe.

Grooving, Circlip Ring Grooves, Slim Widths, With Reduced Cutting depth

Circlip ring grooves comp. to DIN 471/472 and DIN 983/984.
Reduced cutting depth.

Schnittwerte (Start) // Cutting parameters (start)	
f 0,04 mm/U	Vc Seite/Page 429

Passende Klemmhalter auf Seite // Suitable toolholders on page
361, 362, 363, 364, 365, 367, 368

	SP Legende	389
	HM Legend	
	Scan QR-Code	Oder besuchen Sie // Or Visit www.simtek.info/cp/499

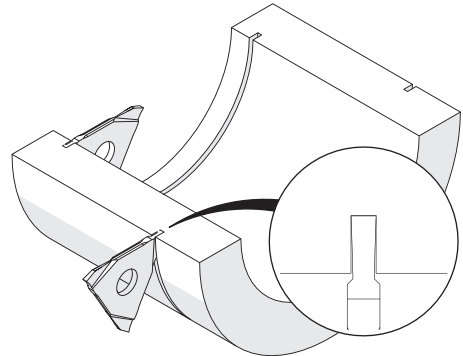
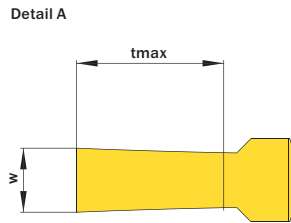
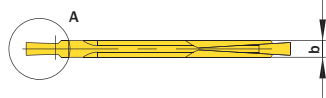
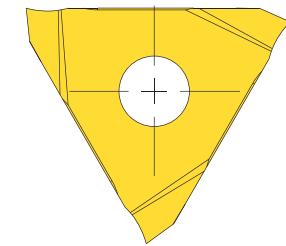


Abbildung zeigt / Drawing shows: E12.1094.00 Z

b ±0,02 mm	Nennbreite Nominal width of groove mm	Artikelnummer Part number	Webcode www.simtek.com/webcode	Unsere erste Wahl Our first choice	tmax mm	w -0,05 mm	Connectcode www.simtek.com/ccode
1,3	0,34	E12.1034.00 Z	AHE9	X808 X408	0,6	0,4	E12.A1 E12.A2
1,3	0,44	E12.1044.00 Z	AJAV	X808 X408	0,7	0,5	E12.A1 E12.A2
1,3	0,5	E12.1050.00 Z	ANE0	X808 X408	0,9	0,57	E12.A1 E12.A2
1,3	0,54	E12.1054.00 Z	AHZF	X808 X408	0,8	0,6	E12.A1 E12.A2
1,3	0,6	E12.1060.00 Z	APXN	X808 X408	1,1	0,67	E12.A1 E12.A2
1,3	0,64	E12.1064.00 Z	AC2C	X808 X408	1,0	0,7	E12.A1 E12.A2
1,3	0,7	E12.1070.00 Z	AD4M	X808 X408	1,7	0,77	E12.A1 E12.A2
1,3	0,74	E12.1074.00 Z	ANH3	X808 X408	1,7	0,8	E12.A1 E12.A2
1,3	0,8	E12.1080.00 Z	ADDH	X808 X408	2,3	0,87	E12.A1 E12.A2
1,3	0,85	E12.1085.00 Z	AAUW	X808 X408	2,3	0,91	E12.A1 E12.A2
1,3	0,9	E12.1090.00 Z	ADHX	X808 X408	2,3	0,97	E12.A1 E12.A2
1,3	0,94	E12.1094.00 Z	AMUD	X808 X408	2,3	1,0	E12.A1 E12.A2
1,3	1,0	E12.1100.00 Z	AB93	X808 X408	2,3	1,07	E12.A1 E12.A2
1,3	1,05	E12.1105.00 Z	AH3J	X808 X408	2,3	1,12	E12.A1 E12.A2
1,3	1,1	E12.1115.00 Z	AEHY	X808 X408	2,5	1,22	E12.A1 E12.A2

Bestellbeispiel // Order example: **E12.1094.00 Z X808** (X808 = Schneidstoff // Grade)

simturn AX
simturn DX
simturn PX
simturn H2
simturn H2
simturn K2
simturn C4
simturn GX
simturn E3
simturn E12
simturn FX
simturn Decoletage
simturn OA
Index

Stechen, schmale Sicherungsringnuten

Sicherungsringnuten, vgl. DIN 471/472 sowie DIN 983/984.

Grooving, Circlip Ring Grooves, slim widths

Circlip ring grooves comp. to DIN 471/472 and DIN 983/984.

Schnittwerte (Start) // Cutting parameters (start)

f	Vc
0,04 mm/U	Seite/Page 429

Passende Klemmhalter auf Seite // Suitable toolholders on page

361, 362, 363, 364, 365, 367, 368



SP Legende
HM Legend

389

Scan QR-Code

Oder besuchen Sie // Or Visit
www.simtek.info/cp/498

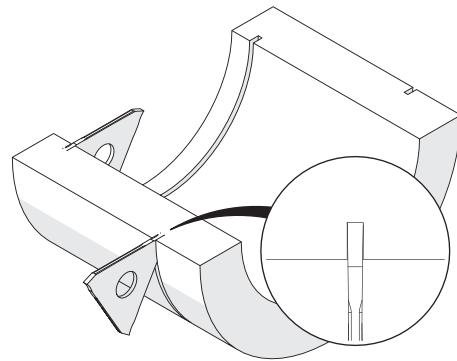
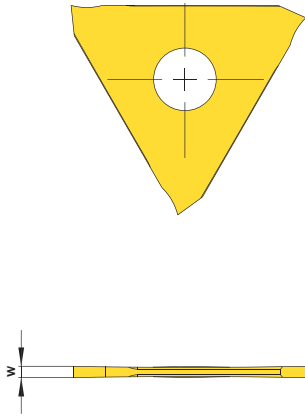


Abbildung zeigt / Drawing shows: E12.0100.00 H

Nennbreite Nominal width of groove mm	Artikelnummer Part number	Webcode www.simtek.com/webcode	Unsere erste Wahl Our first choice	w ^{+0,03} mm		Connectcode www.simtek.com/code
				P	K M N S	
0,5	E12.0050.00 H	AM9A	X808 X408		0,53	E12.A1
0,6	E12.0060.00 H	ABMF	X808 X408		0,63	E12.A1
0,7	E12.0070.00 H	AHDK	X808 X408		0,73	E12.A1
0,8	E12.0080.00 H	AKMH	X808 X408		0,83	E12.A1
0,9	E12.0090.00 H	AA2Z	X808 X408		0,93	E12.A1
1,0	E12.0100.00 H	APFD	X808 X408		1,03	E12.A1 E12.A2

Bestellbeispiel // Order example: **E12.0100.00 H X808** (X808 = Schneidstoff // Grade)

Stechen, Sicherungsringnuten

Sicherungsringnuten, vgl. DIN 471/472 sowie DIN 983/984.

Grooving, Circlip Ring Grooves

Circlip ring grooves comp. to DIN 471/472 and DIN 983/984.

Schnittwerte (Start) // Cutting parameters (start)	
f 0,04 mm/U	Vc Seite/Page 429

Passende Klemmhalter auf Seite // Suitable toolholders on page
361, 362, 363, 364, 365, 367, 368

SP

Legende

HM

Legende

Scan QR-Code

389

Oder besuchen Sie // Or Visit
www.simtek.info/cp/500

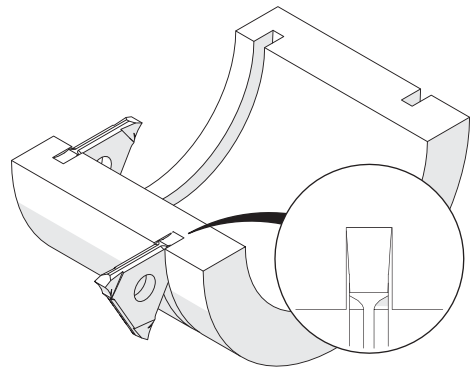
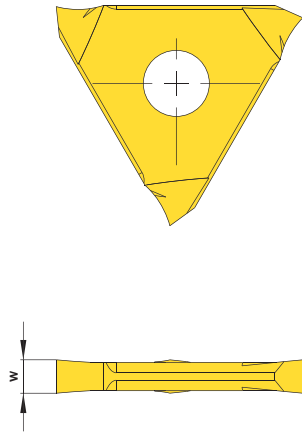


Abbildung zeigt / Drawing shows: E12.0265.00 G

Nennbreite Nominal width of groove mm	Artikelnummer Part number	Webcode www.simtek.com/webcode	Unsere erste Wahl Our first choice	w ^{+0,03} mm		Connectcode www.simtek.com/ccode
				P	K	
1,1	E12.0110.00 G	AN0Z	X800 X600		1,2	E12.A1 E12.A2
1,3	E12.0130.00 G	AG7C	X800 X600		1,4	E12.A1 E12.A2
1,6	E12.0160.00 G	AE2Y	X800 X600		1,7	E12.A1 E12.A2
1,85	E12.0185.00 G	AMUJ	X800 X600		1,95	E12.A1 E12.A2
2,15	E12.0215.00 G	ANBG	X800 X600		2,25	E12.A2 E12.B2
2,65	E12.0265.00 G	AKPW	X800 X600		2,75	E12.B2
3,15	E12.0315.00 G	AFFJ	X800 X600		3,25	E12.C3
4,15	E12.0415.00 G	AEBD	X800 X600		4,25	E12.D4
5,15	E12.0515.00 G	AJMV	X800 X600		5,25	E12.D4

Bestellbeispiel // Order example: **E12.0110.00 G X800** (X800 = Schneidstoff // Grade)



E12. w, 1/100 mm, 4 Stellen/Digits . R, 1/100 mm, 3 Stellen/Digits Toleranz // Tolerance
 Beispielartikelnummer // Example Part number: **E12.0156.015 XN**

simturn AX
simturn DX
simturn PX
simturn H2
simturn K2
simturn C4
simturn GX
simturn E3
simturn E12
simturn FX
simturn Decolletage
simturn OA
Index

Einstecken

Für allgemeines Nutenstechen.

Grooving

For general grooving.

Schnittwerte (Start) // Cutting parameters (start)

f	Vc
0,04 mm/U	Seite/Page 429

Passende Klemmhalter auf Seite // Suitable toolholders on page

361, 362, 363, 364, 365, 367, 368



SP Legende
HM Legend

389

Scan QR-Code

Oder besuchen Sie // Or Visit
www.simtek.info/cp/1249

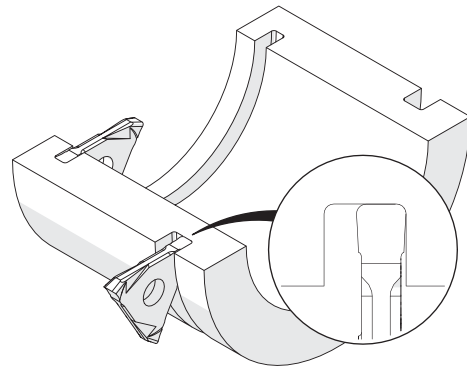
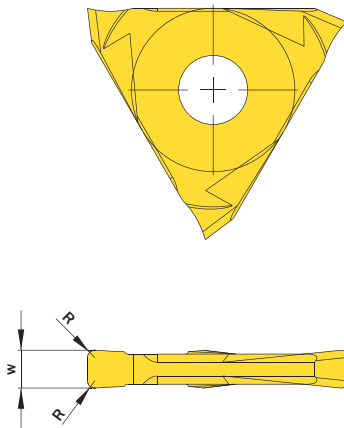


Abbildung zeigt / Drawing shows: E12.0300.06 N

$w^{+0,02}$ mm	R mm	Artikelnummer Part number	Webcode www.simtek.com/webcode	Unsere erste Wahl Our first choice P K M N S	Connectcode www.simtek.com/code	
▼ w = 1,168 mm						
1,168	-	E12.0117.00 G	AJEW	X800 X600	E12.A1 E12.A2	Inch
▼ w = 1,422 mm						
1,422	-	E12.0142.00 G	AF62	X800 X600	E12.A1 E12.A2	Inch
▼ w = 1,575 mm						
1,575	-	E12.0157.00 G	AC0A	X800 X600	E12.A1 E12.A2	Inch
▼ w = 2,388 mm						
2,388	-	E12.0238.00 G	AFU1	X800 X600	E12.B2	Inch
▼ w = 3,175 mm						
3,175	-	E12.0318.00 G	ADJ8	X800 X600	E12.C3	Inch

Bestellbeispiel // Order example: **E12.0142.00 G X800** (X800 = Schneidstoff // Grade)

Stechen, Sicherungsringnuten, mit geschliffener Spanformrille

Sicherungsringnuten, vgl. DIN 471/472 sowie DIN 983/984. Mit geschliffener Spanformrille.

Grooving, Circlip Ring Grooves, With Ground Chip Form Channel

Circlip ring grooves comp. to DIN 471/472 and DIN 983/984. With ground chip form channel.

Schnittwerte (Start) // Cutting parameters (start)

f	Vc
0,08 mm/U	Seite/Page 429

Passende Klemmhalter auf Seite // Suitable toolholders on page

361, 362, 363, 364, 365, 367, 368

SP
Legende

HM
Legende

Scan QR-Code

389

Oder besuchen Sie // Or Visit
www.simtek.info/cp/503

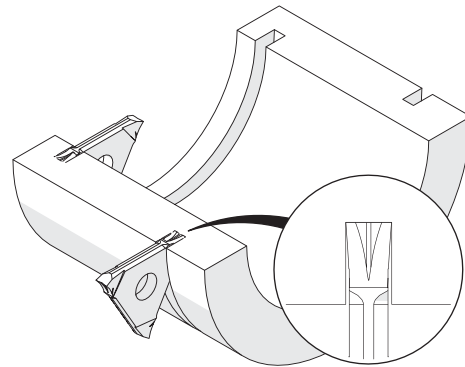
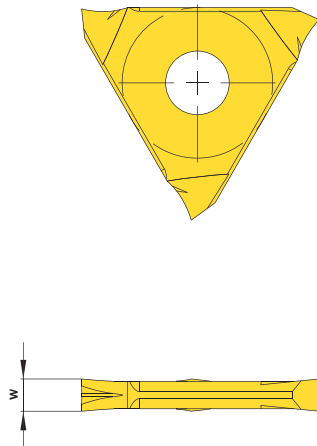


Abbildung zeigt / Drawing shows: E12.0265.11 K

Nennbreite Nominal width of groove	Artikelnummer Part number	Webcode www.simtek.com/webcode	Unsere erste Wahl Our first choice	w ^{+0,03}		Connectcode www.simtek.com/ccode
				mm	mm	
1,1	E12.0110.11 K	AJBT	X800 X600	1,2		E12.A1 E12.A2
1,3	E12.0130.11 K	AJJ3	X800 X600	1,4		E12.A1 E12.A2
1,6	E12.0160.11 K	ACKU	X800 X600	1,7		E12.A1 E12.A2
1,85	E12.0185.11 K	AK7B	X800 X600	1,95		E12.A1 E12.A2
2,15	E12.0215.11 K	AH5U	X800 X600	2,25		E12.A2 E12.B2
2,65	E12.0265.11 K	AH76	X800 X600	2,75		E12.B2
3,15	E12.0315.11 K	AE79	X800 X600	3,25		E12.C3

Bestellbeispiel // Order example: **E12.0185.11 K X800** (X800 = Schneidstoff // Grade)

simturn AX
simturn DX
simturn PX
simturn H2
simturn K2
simturn C4
simturn GX
simturn E3
simturn E12
simturn FX
simturn Decolletage
simturn OA
Index

Drehbearbeitung, vorwiegend außen // Mainly External Grooving and Turning
 simturn E12 > Schneidwerkzeug // Cutting Tool

Stechen, Sicherungsringnuten, mit 0° Spanwinkel

Sicherungsringnuten, vgl. DIN 471/472 sowie DIN 983/984. Mit 0° Spanwinkel.

Grooving, Circlip Ring Grooves, With 0° Rake Angle

Circlip ring grooves comp. to DIN 471/472 and DIN 983/984. With 0° rake angle.

Schnittwerte (Start) // Cutting parameters (start)

f	Vc
0,04 mm/U	Seite/Page 429

Passende Klemmhalter auf Seite // Suitable toolholders on page

361, 362, 363, 364, 365, 367, 368



SP Legende
HM Legend

389

Scan QR-Code

Oder besuchen Sie // Or Visit www.simtek.info/cp/502

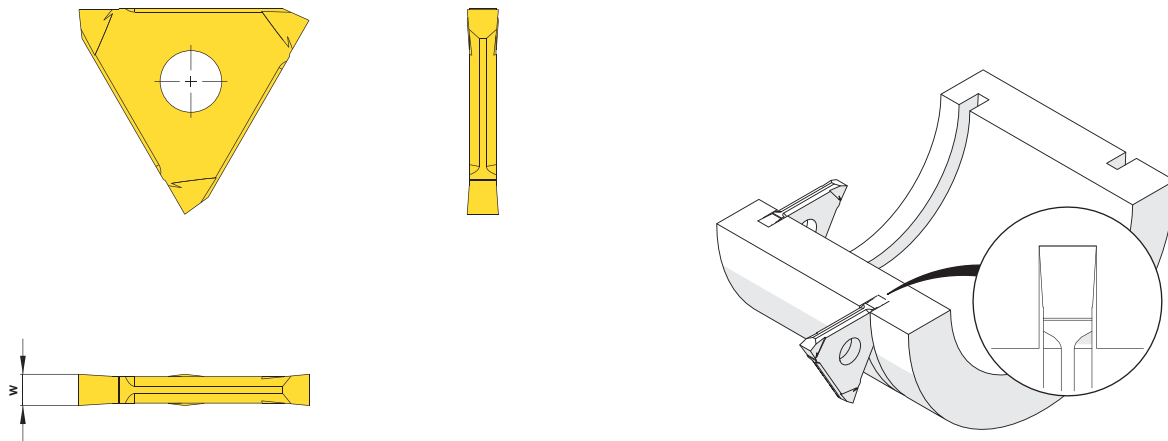


Abbildung zeigt / Drawing shows: E12.0265.00 GU

Nennbreite Nominal width of groove mm	Artikelnummer Part number	Webcode www.simtek.com/webcode	Unsere erste Wahl Our first choice	w ^{+0,03}		Connectcode www.simtek.com/code
				mm	mm	
1,1	E12.0110.00 GU	AAEQ	X808 X408	1,2		E12.A1 E12.A2
1,3	E12.0130.00 GU	AFC2	X808 X408	1,4		E12.A1 E12.A2
1,6	E12.0160.00 GU	AK23	X808 X408	1,7		E12.A1 E12.A2
1,85	E12.0185.00 GU	ABVN	X808 X408	1,95		E12.A1 E12.A2
2,15	E12.0215.00 GU	AMH2	X808 X408	2,25		E12.A2 E12.B2
2,65	E12.0265.00 GU	ABGY	X808 X408	2,75		E12.B2
3,15	E12.0315.00 GU	AE6N	X808 X408	3,25		E12.C3
4,15	E12.0415.00 GU	AGP6	X808 X408	4,25		E12.D4
5,15	E12.0515.00 GU	AC2Q	X808 X408	5,25		E12.D4

Bestellbeispiel // Order example: **E12.0185.00 GU X808** (X808 = Schneidstoff // Grade)

Stechen, Sicherungsringnuten, mit hochpositivem Spanwinkel

Sicherungsringnuten, vgl. DIN 471/472 sowie DIN 983/984.
 Mit hochpositivem Spanwinkel, besonders geeignet für Leichtmetalle.

Grooving, Circlip Ring Grooves, with high positive rake angle

Circlip ring grooves comp. to DIN 471/472 and DIN 983/984.
 With high positive rake angle, especially for light alloys.

Schnittwerte (Start) // Cutting parameters (start)	
f 0,04 mm/U	Vc Seite/Page 429

Passende Klemmhalter auf Seite // Suitable toolholders on page
361, 362, 363, 364, 365, 367, 368

SP

HM

LM

Legende Legend **389**

Scan QR-Code Oder besuchen Sie // Or Visit
www.simtek.info/cp/501

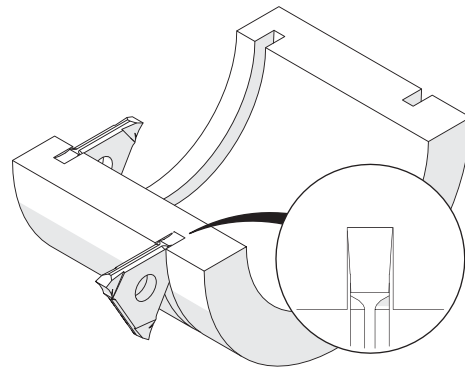
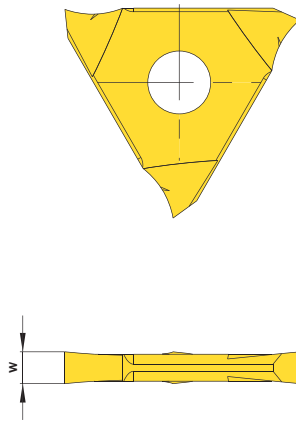


Abbildung zeigt / Drawing shows: E12.0265.40 C

Nennbreite Nominal width of groove mm	Artikelnummer Part number	Webcode www.simtek.com/webcode	Unsere erste Wahl Our first choice	w ^{+0,03} mm		Connectcode www.simtek.com/ccode
				P	K M N S	
1,1	E12.0110.40 C	AGD1	X808 X408		1,2	E12.A1 E12.A2
1,3	E12.0130.40 C	AA6C	X808 X408		1,4	E12.A1 E12.A2
1,6	E12.0160.40 C	AGFW	X808 X408		1,7	E12.A1 E12.A2
1,85	E12.0185.40 C	ACVX	X808 X408		1,95	E12.A1 E12.A2
2,15	E12.0215.40 C	AENS	X808 X408		2,25	E12.A2 E12.B2
2,65	E12.0265.40 C	AFXA	X808 X408		2,75	E12.B2
3,15	E12.0315.40 C	AA3S	X808 X408		3,25	E12.C3
4,15	E12.0415.40 C	AK3D	X808 X408		4,25	E12.D4
5,15	E12.0515.40 C	AM1M	X808 X408		5,25	E12.D4

Bestellbeispiel // Order example: **E12.0130.40 C X808** (X808 = Schneidstoff // Grade)

simturn AX
simturn DX
simturn PX
simturn H2
simturn K2
simturn C4
simturn GX
simturn E3
simturn E12
simturn FX
simturn Decolletage
simturn OA
Index

Stechdrehen, Sicherungsringnuten mit Fassung

Sicherungsringnuten vgl. DIN 471/472 sowie DIN 983/984, mit Nutaußenkantenfasung.

Grooving, Circlip Ring Grooves with Chamfer

Circlip ring grooves comp. to DIN 471/472 and DIN 983/984, with chamfer.

Schnittwerte (Start) // Cutting parameters (start)

f	Vc
0,04 mm/U	Seite/Page 429

Passende Klemmhalter auf Seite // Suitable toolholders on page
361, 362, 363, 364, 365, 367



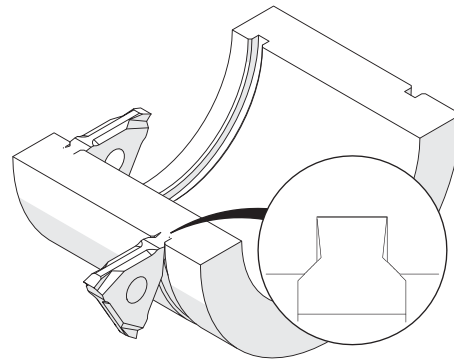
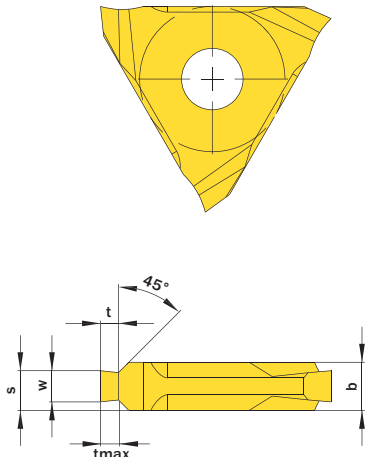
SP Legende
HM Legend

389



Scan QR-Code

Oder besuchen Sie // Or Visit
www.simtek.info/cp/504



Nutnenbreite Nominal width of groove	t _{max}	b ±0,02	Artikelnummer Part number	Webcode www.simtek.com/webcode	Unsere erste Wahl Our first choice	S	t	w ^{+0,03}	Connectcode www.simtek.com/ccode
mm	mm	mm			P K M N S	mm	mm	mm	
▼ Nutnenbreite // Nominal width of groove = 1,1 mm									
1,1	0,25	2,5	E12.1102.25 F	ACC7	X800 X600	1,88	0,24	1,2	E12.A2 E12.B2
1,1	0,3	2,5	E12.1103.25 F	AC0T	X800 X600	1,88	0,29	1,2	E12.A2 E12.B2
1,1	0,35	2,5	E12.1104.25 F	AE1Y	X800 X600	1,88	0,33	1,2	E12.A2 E12.B2
1,1	0,4	2,5	E12.1105.25 F	AJ1V	X800 X600	1,88	0,36	1,2	E12.A2 E12.B2
▼ Nutnenbreite // Nominal width of groove = 1,3 mm									
1,3	0,55	2,5	E12.1306.25 F	ACN1	X800 X600	1,98	0,45	1,4	E12.A2 E12.B2
▼ Nutnenbreite // Nominal width of groove = 1,6 mm									
1,6	0,7	3,3	E12.1607.33 F	AJY0	X800 X600	2,53	0,6	1,7	E12.C3
1,6	0,85	3,3	E12.1608.33 F	AF23	X800 X600	2,53	0,75	1,7	E12.C3
1,6	1,0	3,3	E12.1609.33 F	AM03	X800 X600	2,53	0,85	1,7	E12.C3
▼ Nutnenbreite // Nominal width of groove = 1,85 mm									
1,85	1,0	3,3	E12.1810.33 F	AD4J	X800 X600	2,66	0,85	1,95	E12.C3
1,85	1,25	3,3	E12.1812.33 F	APZ1	X800 X600	2,66	1,1	1,95	E12.C3
▼ Nutnenbreite // Nominal width of groove = 2,15 mm									
2,15	1,5	4,3	E12.2115.43 F	AK5Q	X800 X600	3,31	1,35	2,25	E12.D4

Verwandte Werkzeuge finden Sie auch auf der folgenden Seite!
 Related Items can be found on the following page as well!

Fortgesetzte Tabelle
 Continued Table

Bestellbeispiel // Order example: **E12.1812.33 F X800** (X800 = Schneidstoff // Grade)

Stechdrehen, Sicherungsringnuten mit Fassung

Sicherungsringnuten vgl. DIN 471/472 sowie DIN 983/984, mit Nutaußenkantenfasung.

Grooving, Circlip Ring Grooves with Chamfer

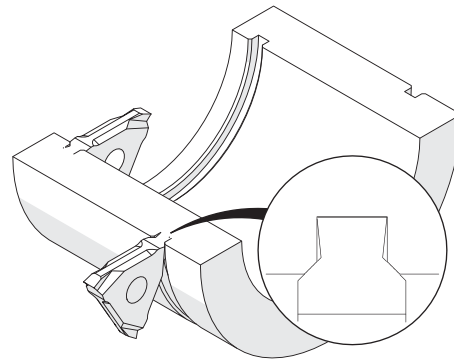
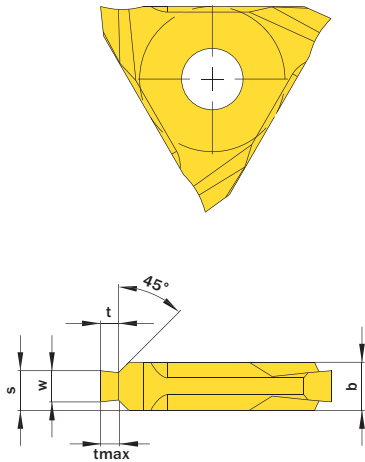
Circlip ring grooves comp. to DIN 471/472 and DIN 983/984, with chamfer.

Schnittwerte (Start) // Cutting parameters (start)

f	Vc
0,04 mm/U	Seite/Page 429

Passende Klemmhalter auf Seite // Suitable toolholders on page
361, 362, 363, 364, 365, 367

	SP	Legende	389
	HM	Legende	
	Scan QR-Code	Oder besuchen Sie // Or Visit www.simtek.info/cp/514	



Nutnenbreite Nominal width of groove	tmax	b ±0,02	Artikelnummer Part number	Webcode www.simtek.com/webcode	Unsere erste Wahl Our first choice	S	t	w +0,03	Connectcode www.simtek.com/code
mm	mm	mm			P K M N S	mm	mm	mm	

◀ Fortgesetzte Tabelle Continued Table **Verwandte Werkzeuge finden Sie auch auf der vorhergehenden Seite!**
Related items can be found on the previous page as well!

▼ Nutnenbreite // Nominal width of groove = 2,65 mm									
2,65	1,5	3,3	E12.2516.33 F	AGJG	X800 X600	3,06	1,35	2,75	E12.C3
2,65	1,5	4,3	E12.2616.43 F	ABGF	X800 X600	3,56	1,35	2,75	E12.D4
2,65	1,75	4,3	E12.2617.43 F	AKMC	X800 X600	3,56	1,6	2,75	E12.D4
▼ Nutnenbreite // Nominal width of groove = 3,15 mm									
3,15	1,75	5,3	E12.3118.53 F	AKWW	X800 X600	4,31	1,6	3,25	E12.D4
▼ Nutnenbreite // Nominal width of groove = 4,15 mm									
4,15	2,0	5,3	E12.4120.53 F	AFQG	X800 X600	4,81	1,85	4,25	E12.D4
4,15	2,5	5,3	E12.4125.53 F	APSU	X800 X600	4,81	2,35	4,25	E12.D4
▼ Nutnenbreite // Nominal width of groove = 5,15 mm									
5,15	3,0	6,3	E12.5130.63 F	AK6G	X800 X600	5,81	2,85	5,25	E12.D4

■ Bestellbeispiel // Order example: **E12.4125.53 F X800** (X800 = Schneidstoff // Grade)

simturn AX
simturn DX
simturn PX
simturn H2
simturn K2
simturn C4
simturn GX
simturn E3
simturn E12
simturn FX
simturn Decolletage
simturn OA
Index

Einstecken und Profildrehen

CNC-Feindrehen.

Grooving and Profiling

CNC profiling.

Schnittwerte (Start) // Cutting parameters (start)

f	Vc
0,04 mm/U	Seite/Page 429

Passende Klemmhalter auf Seite // Suitable toolholders on page
361, 362, 363, 364, 365, 367, 368



SP SP
 CBN HM
 Legende Legend **389**

Scan QR-Code Oder besuchen Sie // Or Visit
www.simtek.info/cp/506

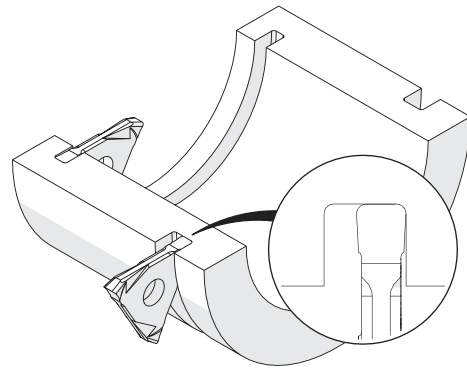
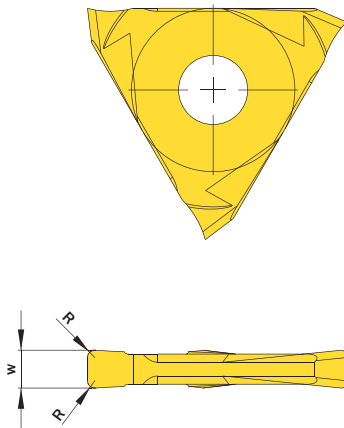


Abbildung zeigt / Drawing shows: E12.0300.06 N

w ^{+0,03} mm	R mm	Artikelnummer Part number	Webcode www.simtek.com/webcode	Unsere erste Wahl Our first choice P K M N S	Connectcode www.simtek.com/code
▼ w = 1,0 mm					
1,0	0,05	E12.0100.00 N	AMFH	X800 X600	E12.A1 E12.A2
1,0	0,2	E12.0100.02 N	AP31	X800 X600	E12.A1 E12.A2
▼ w = 1,5 mm					
1,5	0,05	E12.0150.00 N	AKVM	X800 X600	E12.A1 E12.A2
1,5	0,2	E12.0150.02 N	AEWQ	X800 X600	E12.A1 E12.A2
▼ w = 2,0 mm					
2,0	0,05	E12.0200.00 N	AEVK	X800 X600	E12.A1 E12.A2
2,0	0,2	E12.0200.02 N	AB41	X800 X600	E12.A1 E12.A2
2,0	0,4	E12.0200.04 N	AFS9	X800 X600	E12.A1 E12.A2
▼ w = 2,5 mm					
2,5	0,05	E12.0250.00 N	AG51	X800 X600	E12.A2 E12.B2
2,5	0,2	E12.0250.02 N	AGZ8	X800 X600	E12.A2 E12.B2
2,5	0,4	E12.0250.04 N	AECQ	X800 X600	E12.A2 E12.B2

Verwandte Werkzeuge finden Sie auch auf der folgenden Seite!
 Related Items can be found on the following page as well!

Fortgesetzte Tabelle
 Continued Table

Bestellbeispiel // Order example: **E12.0100.00 N X800** (X800 = Schneidstoff // Grade)



E12. w, 1/100 mm, 4 Stellen/Digits . R, 1/100 mm, 3 Stellen/Digits Toleranz // Tolerance
 Beispielartikelnummer // Example Part number: **E12.0156.015 XN**

Einstecken und Profildrehen

CNC-Feindrehen.

Grooving and Profiling

CNC profiling.

Schnittwerte (Start) // Cutting parameters (start)	
f	Vc
0,04 mm/U	Seite/Page 429

Passende Klemmhalter auf Seite // Suitable toolholders on page
361, 362, 363, 364, 365, 367

SP

Legende

HM

Legende

389

Scan QR-Code

Oder besuchen Sie // Or Visit www.simtek.info/cp/865

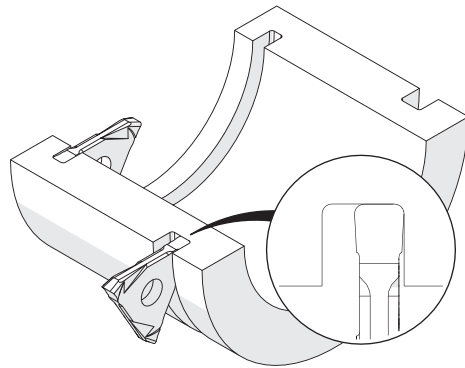
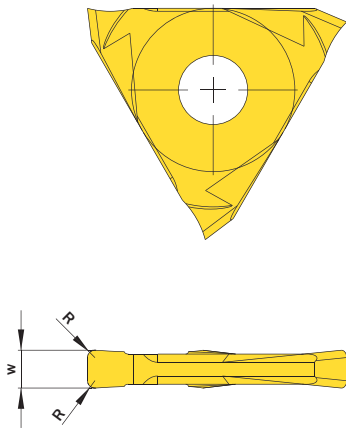


Abbildung zeigt / Drawing shows: E12.0300.06 N

w +0,03 mm	R mm	Artikelnummer Part number	Webcode www.simtek.com/webcode	Unsere erste Wahl Our first choice P K M N S	Connectcode www.simtek.com/code
----------------------	----------------	------------------------------	---	---	---

◀ Fortgesetzte Tabelle Continued Table Verwandte Werkzeuge finden Sie auch auf der vorhergehenden Seite! Related items can be found on the previous page as well!

▼ w = 3,0 mm						
	3,0	0,05	E12.0300.00 N	AGUD	X800 X600	E12.B2
	3,0	0,2	E12.0300.02 N	ABEQ	X800 X600	E12.B2
	3,0	0,4	E12.0300.04 N	AA6U	X800 X600	E12.B2
	3,0	0,6	E12.0300.06 N	AMZM	X800 X600	E12.B2
	3,0	0,8	E12.0300.08 N	AJV3	X800 X600	E12.B2
▼ w = 4,0 mm						
	4,0	0,05	E12.0400.00 N	AP2K	X800 X600	E12.C3
	4,0	0,2	E12.0400.02 N	ADXN	X800 X600	E12.C3
	4,0	0,4	E12.0400.04 N	AFJK	X800 X600	E12.C3
	4,0	0,8	E12.0400.08 N	AJP0	X800 X600	E12.C3
	4,0	1,2	E12.0400.12 N	AKU8	X800 X600	E12.C3

Bestellbeispiel // Order example: **E12.0300.02 N X800** (X800 = Schneidstoff // Grade)



E12. w, 1/100 mm, 4 Stellen/Digits . R, 1/100 mm, 3 Stellen/Digits Toleranz // Tolerance
 Beispielartikelnummer // Example Part number: **E12.0156.015 XN**

simturn AX
simturn DX
simturn PX
simturn H2
simturn K2
simturn C4
simturn GX
simturn E3
simturn E12
simturn FX
simturn Decolletage
simturn OA
Index

Drehbearbeitung, vorwiegend außen // Mainly External Grooving and Turning
 simturn E12 > Schneidwerkzeug // Cutting Tool

Stech- und Längsdrehen, Doppelspanformrille

Stechen und Längsdrehen, außen.
 Mit geschliffener doppelter Spanformrille.

Grooving and Turning, Two Ground Chip Form Channels

Grooving and turning, external.
 With two ground chip form channels.

Schnittwerte (Start) // Cutting parameters (start)

f	Vc
0,08 mm/U	Seite/Page 429

Passende Klemmhalter auf Seite // Suitable toolholders on page
361, 362, 363, 364, 365, 367

	SP	Legende	389
	HM	Legend	
	Scan QR-Code	Oder besuchen Sie // Or Visit www.simtek.info/cp/505	

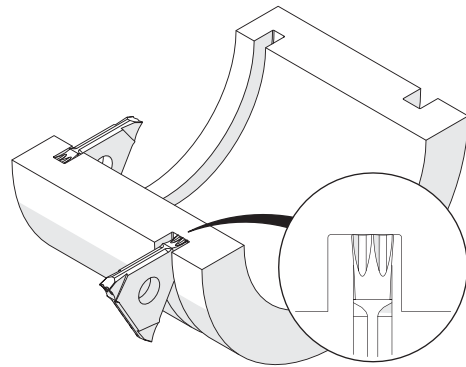
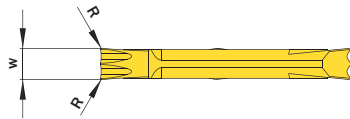
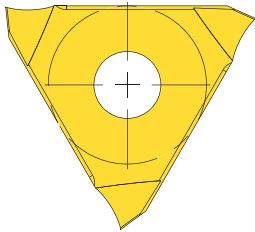


Abbildung zeigt / Drawing shows: E12.0025.44 W

w ^{-0,05}	Artikelnummer Part number	Webcode www.simtek.com/webcode	Unsere erste Wahl Our first choice	R	Connectcode www.simtek.com/code
mm	E12.0025.44 W	AHYP	P K M N S X800 X600	mm	E12.A2 E12.B2
2,5				0,2	

Bestellbeispiel // Order example: **E12.0025.44 W X800** (X800 = Schneidstoff // Grade)

simturn AX

simturn DX

simturn PX

simturn H2

simturn K2

simturn C4

simturn GX

simturn E3

simturn E12

simturn FX

simturn Decolletage

simturn OA

Index

Einstecken und Profildrehen, Vollradius

Vollradiusnuten, CNC-Konturdrehen.

Grooving and Profiling, Full Radius

Full radius, CNC profiling.

Schnittwerte (Start) // Cutting parameters (start)

f	Vc
0,04 mm/U	Seite/Page 429

Passende Klemmhalter auf Seite // Suitable toolholders on page

361, 362, 363, 364, 365, 367, 368



SP Legende
HM Legend

389

Scan QR-Code

Oder besuchen Sie // Or Visit
www.simtek.info/cp/507

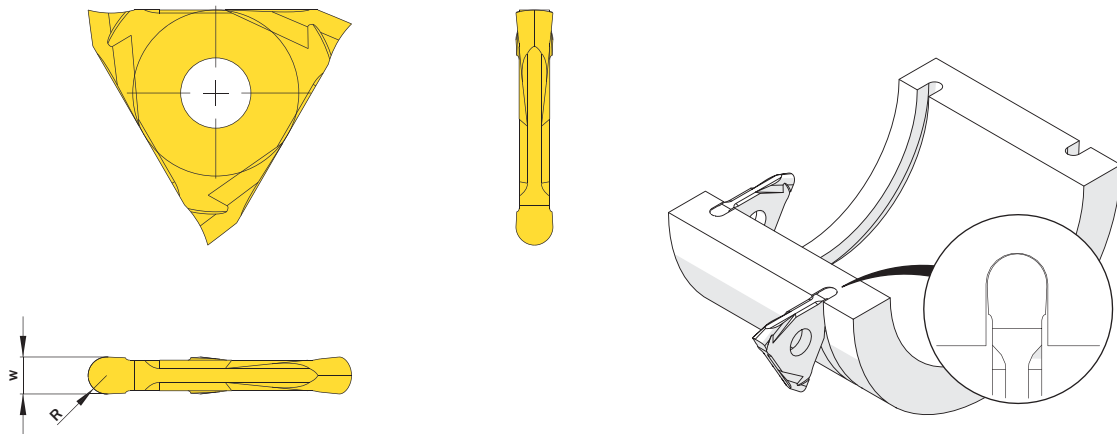


Abbildung zeigt / Drawing shows: E12.0300.15 V

w ^{+0,04}	R	Artikelnummer Part number	Webcode www.simtek.com/webcode	Unsere erste Wahl Our first choice		Connectcode www.simtek.com/ccode
				P	K M N S	
1,0	0,5	E12.0100.05 V	ADKV	X800	X600	E12.A1 E12.A2
1,2	0,6	E12.0120.06 V	AKTC	X800	X600	E12.A1 E12.A2
1,5	0,75	E12.0150.07 V	AMYT	X800	X600	E12.A1 E12.A2
2,0	1,0	E12.0200.10 V	AFZA	X800	X600	E12.A1 E12.A2
2,38	1,19	E12.0238.12 V	A1PG	X800	X600	E12.A1 E12.A2
2,5	1,25	E12.0250.12 V	AH44	X800	X600	E12.A2 E12.B2
3,0	1,5	E12.0300.15 V	AAW2	X800	X600	E12.B2
4,0	2,0	E12.0400.20 V	AFGY	X800	X600	E12.C3

inch

Bestellbeispiel // Order example: **E12.0150.07 V X800** (X800 = Schneidstoff // Grade)

simturn AX
 simturn DX
 simturn PX
 simturn H2
 simturn K2
 simturn C4
 simturn GX
 simturn E3
 simturn E12
 simturn FX
 simturn Decolletage
 simturn OA
 Index

Eckenfreistiche, Vollradius

Eckenfreistiche, Vollradius mit hohen seitlichen Freiwinkeln.

Corner Relief, Full Radius

Corner relief, full radius with increased lateral relief angles.

Schnittwerte (Start) // Cutting parameters (start)

f	Vc
0,04 mm/U	Seite/Page 429

Passende Klemmhalter auf Seite // Suitable toolholders on page

361, 362, 363, 364, 365, 367, 368



SP Legende
HM Legend

389

Scan QR-Code

Oder besuchen Sie // Or Visit
www.simtek.info/cp/508

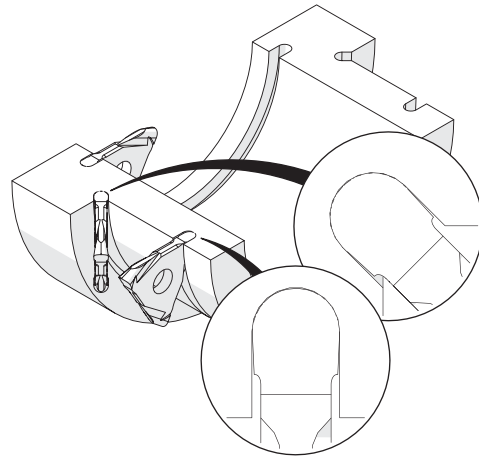
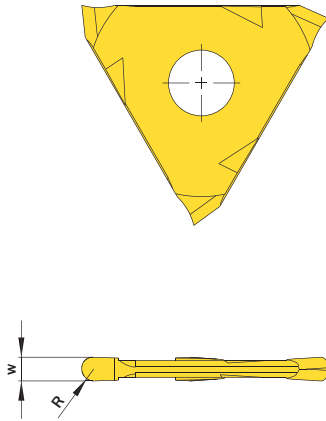


Abbildung zeigt / Drawing shows: E12.0010.20 V

R	w ±0,03	Artikelnummer Part number	Webcode www.simtek.com/webcode	Unsere erste Wahl Our first choice	Connectcode www.simtek.com/code
mm	mm			P K M N S	
1,0	2,0	E12.0010.20 V	AGXF	X800 X600	E12.A1 E12.A2
1,2	2,4	E12.0012.24 V	AM15	X800 X600	E12.A2 E12.B2
1,5	3,0	E12.0015.30 V	APVW	X800 X600	E12.B2
2,0	4,0	E12.0020.40 V	ANJ2	X800 X600	E12.C3
2,5	5,0	E12.0025.50 V	AHJ2	X800 X600	E12.D4
3,0	6,0	E12.0030.60 V	AJ0T	X800 X600	E12.D4

Bestellbeispiel // Order example: **E12.0012.24 V X800** (X800 = Schneidstoff // Grade)

Stechen, Runddrahtsprengringe

Runddrahtsprengringe, vgl. DIN 7993.

Grooving, Round-Wire Snap-Ring

Round-wire snap-ring, comparing to DIN 7993.

Schnittwerte (Start) // Cutting parameters (start)

f	Vc
0,04 mm/U	Seite/Page 429

Passende Klemmhalter auf Seite // Suitable toolholders on page

361, 362, 363, 364, 365, 367, 368



SP Legende
HM Legend

389



Scan
 QR-Code

Oder besuchen Sie // Or Visit
www.simtek.info/cp/497

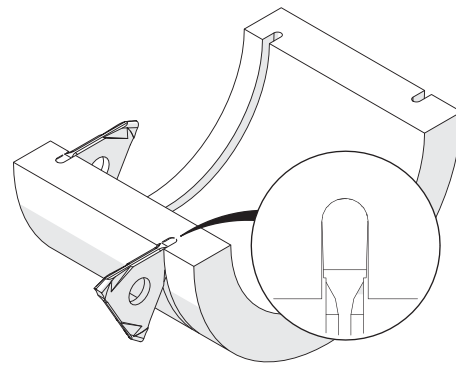
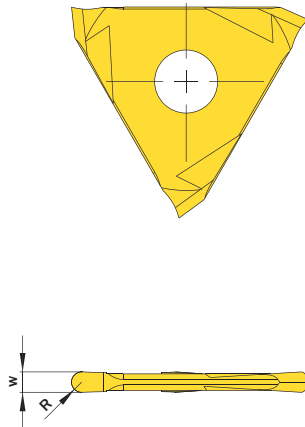


Abbildung zeigt / Drawing shows: E12.0009.00 V

R	Artikelnummer Part number	Webcode www.simtek.com/webcode	Unsere erste Wahl Our first choice	w ±0,03	Connectcode www.simtek.com/ccode
mm			P K M N S	mm	
0,8	E12.0008.00 V	AAUG	X800 X600	1,6	E12.A1 E12.A2
0,9	E12.0009.00 V	AGCW	X800 X600	1,8	E12.A1 E12.A2
1,1	E12.0011.00 V	AM8P	X800 X600	2,2	E12.A2 E12.B2
1,4	E12.0014.00 V	AG9V	X800 X600	2,8	E12.B2
1,8	E12.0018.00 V	ABHS	X800 X600	3,6	E12.C3

Bestellbeispiel // Order example: **E12.0008.00 V X800** (X800 = Schneidstoff // Grade)

Stechen, schmale Runddrahtsprengringe

Runddrahtsprengringe, vgl. DIN 7993.

Grooving, Slim Round-Wire Snap-Ring

Round-wire snap-ring, comparing to DIN 7993.

Schnittwerte (Start) // Cutting parameters (start)

f	Vc
0,04 mm/U	Seite/Page 429

Passende Klemmhalter auf Seite // Suitable toolholders on page

361, 362, 363, 364, 365, 367, 368



SP Legende
HM Legend

389

Scan QR-Code

Oder besuchen Sie // Or Visit
www.simtek.info/cp/496

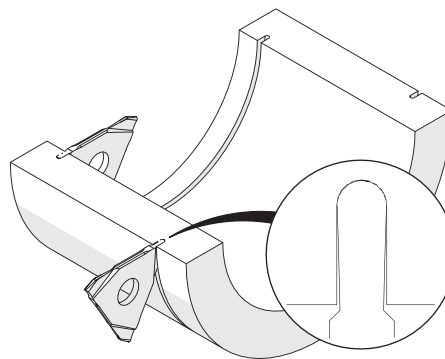
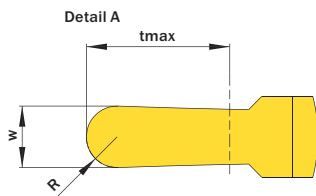
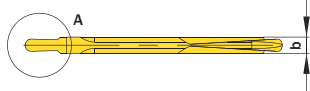
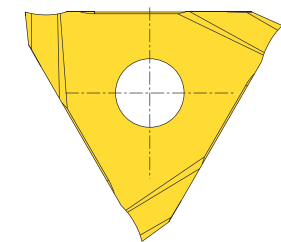


Abbildung zeigt / Drawing shows: E12.1305.00 V

$b \pm 0,02$	R	Artikelnummer Part number	Webcode www.simtek.com/webcode	Unsere erste Wahl Our first choice	tmax	$w \pm 0,03$	Connectcode www.simtek.com/ccode
mm	mm			P K M N S	mm	mm	
1,3	0,2	E12.1302.00 V	AMYV	X800 X600	0,6	0,4	E12.A1 E12.A2
1,3	0,25	E12.1302.05 V	A2WD	X800 X600	0,85	0,5	E12.A1 E12.A2
1,3	0,3	E12.1303.00 V	AC92	X800 X600	1,1	0,6	E12.A1 E12.A2
1,3	0,4	E12.1304.00 V	AA2Q	X800 X600	1,8	0,8	E12.A1 E12.A2
1,3	0,5	E12.1305.00 V	AMD3	X800 X600	2,3	1,0	E12.A1 E12.A2
1,3	0,6	E12.1306.00 V	AN0T	X800 X600	2,5	1,2	E12.A1 E12.A2

Bestellbeispiel // Order example: **E12.1304.00 V X800** (X800 = Schneidstoff // Grade)

Gewindfreistriche

Gewindfreistriche, vgl. DIN 76 Form B.

Thread Reliefs

Thread reliefs, comp. to DIN 76 profil B.

Schnittwerte (Start) // Cutting parameters (start)	
f	Vc
0,04 mm/U	Seite/Page 429

Passende Klemmhalter auf Seite // Suitable toolholders on page
361, 362, 363, 364, 365, 367, 368

SP

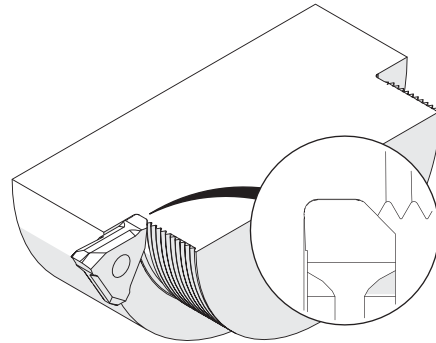
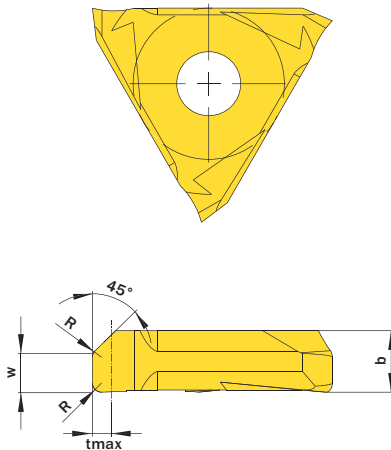
HM

R

Legende
Legend **389**

Scan
QR-Code

Oder besuchen Sie // Or Visit
www.simtek.info/cp/873



Gewindfreistriche nach DIN 76 Form A auf Anfrage erhältlich. // Thread reliefs according to DIN 76 profile A available upon request.

Abbildung zeigt / Drawing shows: E12.3150.53 E R

Steigung (von) Pitch (as of)	b	Artikelnummer Part number	Webcode www.simtek.com/webcode	Unsere erste Wahl Our first choice					R	tmax	w	Connectcode www.simtek.com/ccode
				P	K	M	N	S				
▼ Steigung (von) // Pitch (as of) = 0,5 mm												
0,5	1,7	E12.1050.17 E R/L	R AKSN L AF3B X800 X600				0,2	0,4	0,6	E12.A1 E12.A2		
▼ Steigung (von) // Pitch (as of) = 0,8 mm												
0,8	2,7	E12.1080.27 E R/L	R AATG L ADUS X800 X600				0,4	0,65	0,95	E12.B2		
▼ Steigung (von) // Pitch (as of) = 1,0 mm												
1,0	2,7	E12.1100.27 E R/L	R AG81 L ANYY X800 X600				0,6	0,8	1,2	E12.B2		
▼ Steigung (von) // Pitch (as of) = 1,25 mm												
1,25	2,7	E12.1125.27 E R/L	R AAJH L AG1Y X800 X600				0,6	1,0	1,5	E12.B2		
▼ Steigung (von) // Pitch (as of) = 1,5 mm												
1,5	3,7	E12.1150.37 E R/L	R AGCV L AK0V X800 X600				0,8	1,15	1,85	E12.C3		
▼ Steigung (von) // Pitch (as of) = 1,75 mm												
1,75	3,7	E12.1175.37 E R/L	R AP4F L AEWN X800 X600				1,0	1,3	2,2	E12.C3		
▼ Steigung (von) // Pitch (as of) = 2,0 mm												
2,0	5,3	E12.1200.53 E R/L	R AJXB L AFHY X800 X600				1,0	1,5	2,5	E12.D4		
▼ Steigung (von) // Pitch (as of) = 2,5 mm												
2,5	5,3	E12.1250.53 E R/L	R AMPE L AMXK X800 X600				1,2	1,8	3,2	E12.D4		
▼ Steigung (von) // Pitch (as of) = 3,0 mm												
3,0	6,3	E12.1300.63 E R/L	R AH9W L AFPX X800 X600				1,6	2,2	3,8	E12.D4		

Verwandte Werkzeuge finden Sie auch auf der folgenden Seite!
Related Items can be found on the following page as well!

Fortgesetzte Tabelle
Continued Table

Bestellbeispiel // Order example: **E12.1080.27 E R X800** (R = Rechte Ausführung // Right hand version, X800 = Schneidstoff // Grade)

Abstechen

Verfügbar in verschiedenen Winkeln,
 Breiten und mit/ohne geschliffener Spanformrinne.

Parting Off

Available in different angles,
 widths and with/without ground chip form channel.

Schnittwerte (Start) // Cutting parameters (start)

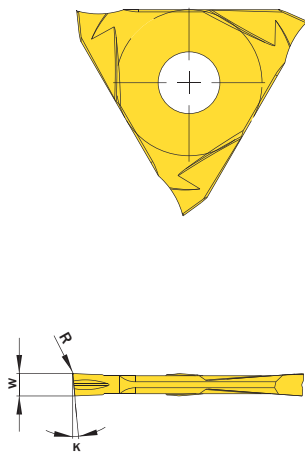
f	Vc
0,08 mm/U	Seite/Page 429

Passende Klemmhalter auf Seite // Suitable toolholders on page
361, 362, 363, 364, 365, 366, 367, 368

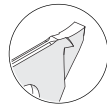


SP
HM
R Legende
 Legend **389**

Scan QR-Code Oder besuchen Sie // Or Visit
www.simtek.info/cp/513



Abbildungen ähnlich // Similar illustrations



E12...00 P R
 E12...PS R



E12...11 P R
 E12...PT R

! Bearbeitbare Materialien. Siehe unten.
 Machineable materials. See below.

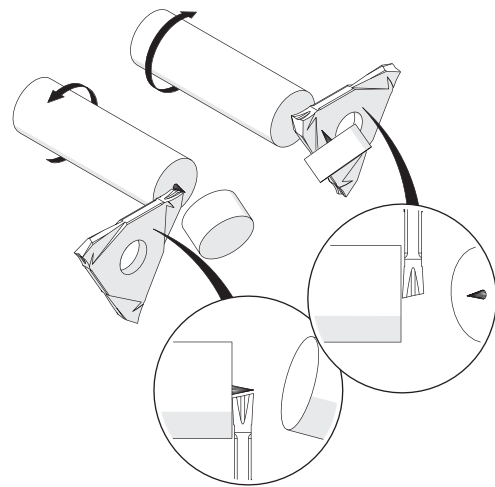


Abbildung zeigt / Drawing shows: E12.1520.11 P R

K	w ^{-0,05} mm	Artikelnummer Part number	Webcode www.simtek.com/webcode	Unsere erste Wahl Our first choice	Mit Spanformrinne With chip form channel	R	Connectcode www.simtek.com/code
▼ w = 1,0 mm							
12°	1,0	E12.1210.00 P R/L	R AFQD L AB4M X800 X600	Nein / No	0,1	E12.A1 E12.A2	
12°	1,0	E12.1210.11 P R/L	R ANDX L AMEB X800 X600	Ja / Yes	0,1	E12.A1 E12.A2	
▼ w = 1,3 mm							
6°-7°	1,3	E12.0613.11 P R/L	R ABPV L AEZZ X800 X600	Ja / Yes	0,1	E12.A1 E12.A2	
▼ w = 1,6 mm							
6°-7°	1,6	E12.0516.00 P R/L	R ACV8 L AF73 X800 X600	Nein / No	0,1	E12.A1 E12.A2	
6°-7°	1,6	E12.0516.11 P R/L	R AMGM L ACKA X800 X600	Ja / Yes	0,1	E12.A1 E12.A2	
6°-7°	1,6	E12.0516.68 PS R/L	R AWEK L AWEN X800 X600	Nein / No	0,1	E68.A1	
6°-7°	1,6	E12.0516.68 PT R/L	R AWEQ L AWEP X800 X600	Ja / Yes	0,1	E68.A1	
▼ w = 2,0 mm							
5°-6°	2,0	E12.0520.00 P R/L	R AC2J L ACEX X800 X600	Nein / No	0,1	E12.A1 E12.A2	
5°-6°	2,0	E12.0520.11 P R/L	R ANDM L AJEN X800 X600	Ja / Yes	0,1	E12.A1 E12.A2	
15°	2,0	E12.1520.11 P R/L	R AFED L APJT X800 X600	Ja / Yes	0,1	E12.A1 E12.A2	
▼ w = 2,1 mm							
5°-6°	2,1	E12.0521.11 P R/L	R AN1B L AHHT X800 X600	Ja / Yes	0,1	E12.A2 E12.B2	

! Bestellbeispiel // Order example: **E12.1210.11 P R X800** (R = Rechte Ausführung // Right hand version, X800 = Schneidstoff // Grade)

! E12...00 P R / E12...PS R: Für die Bearbeitung eines breiten Metarialspektrums // For a wide variety of workpiece materials.

! E12...11 P R / E12...PT R: Für die Bearbeitung eines breiten Metarialspektrums sowie besonders für langspanendes Material und hohe Stechtiefen.
 For a wide variety of workpiece materials as well as especially for long-chipping materials and high cutting depths.

Axialstechen

Für die Herstellung von Axialnuten.

Face Grooving

For face grooves in different widths.

Schnittwerte (Start) // Cutting parameters (start)

f	Vc
0,04 mm/U	Seite/Page 429

Passende Klemmhalter auf Seite // Suitable toolholders on page
361, 362, 363, 364, 365, 367

SP

HM

R

Legende
Legend

389

Scan
QR-Code

Oder besuchen Sie // Or Visit
www.simtek.info/cp/509

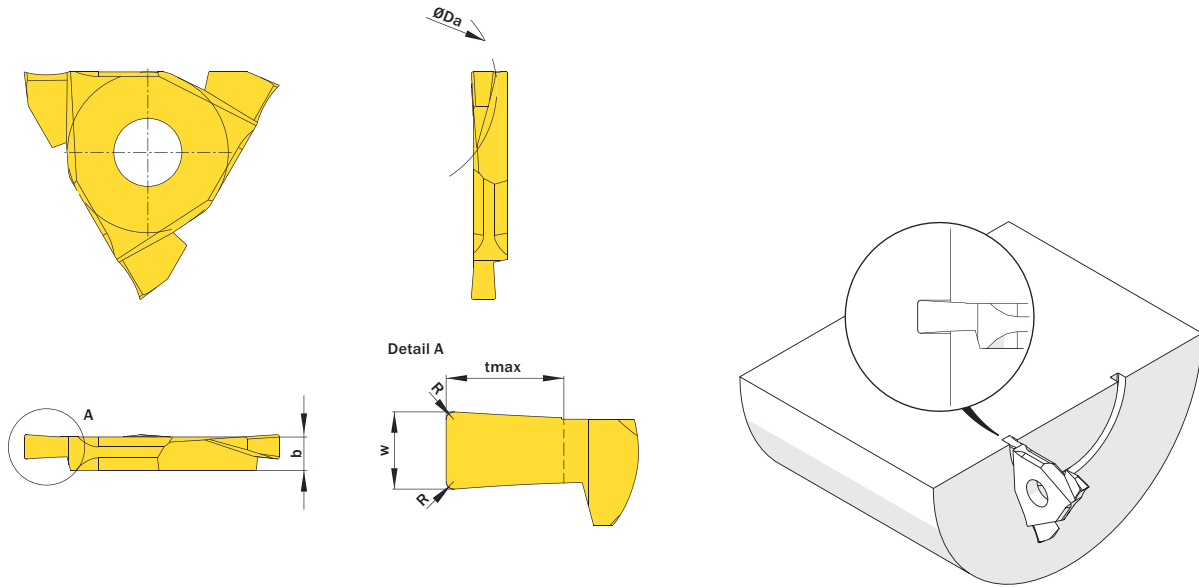


Abbildung zeigt / Drawing shows: E12.3020.02 A R

w ±0,02 mm	Artikelnummer Part number	Webcode www.simtek.com/webcode	Unsere erste Wahl Our first choice	b mm	ØDa mm	R mm	tmax mm	Connectcode www.simtek.com/code
1,5	E12.2015.02 A R/L	R AM85 L AMEV	X800 X600	2,7	30,0	0,2	2,0	E12.B2
2,0	E12.3020.02 A R/L	R ADEQ L APQJ	X800 X600	2,7	30,0	0,2	3,0	E12.B2
3,0	E12.3030.02 A R/L	R ADK0 L AK9X	X800 X600	3,7	30,0	0,2	3,0	E12.C3

Bestellbeispiel // Order example: **E12.3020.02 A R X800** (R = Rechte Ausführung // Right hand version, X800 = Schneidstoff // Grade)

simturn AX
simturn DX
simturn PX
simturn H2
simturn K2
simturn C4
simturn GX
simturn E3
simturn E12
simturn FX
simturn Decolletage
simturn OA
Index

Poly-V-Riemennuten

Für Poly-V-Profile J und K.

Poly-V-Belt Grooves

For Poly-V-profiles J and K.

Schnittwerte (Start) // Cutting parameters (start)

f	Vc
0,04 mm/U	Seite/Page 429

Passende Klemmhalter auf Seite // Suitable toolholders on page

361, 362, 363, 364, 365, 367



SP Legende
HM Legend

389

Scan QR-Code

Oder besuchen Sie // Or Visit
www.simtek.info/cp/512

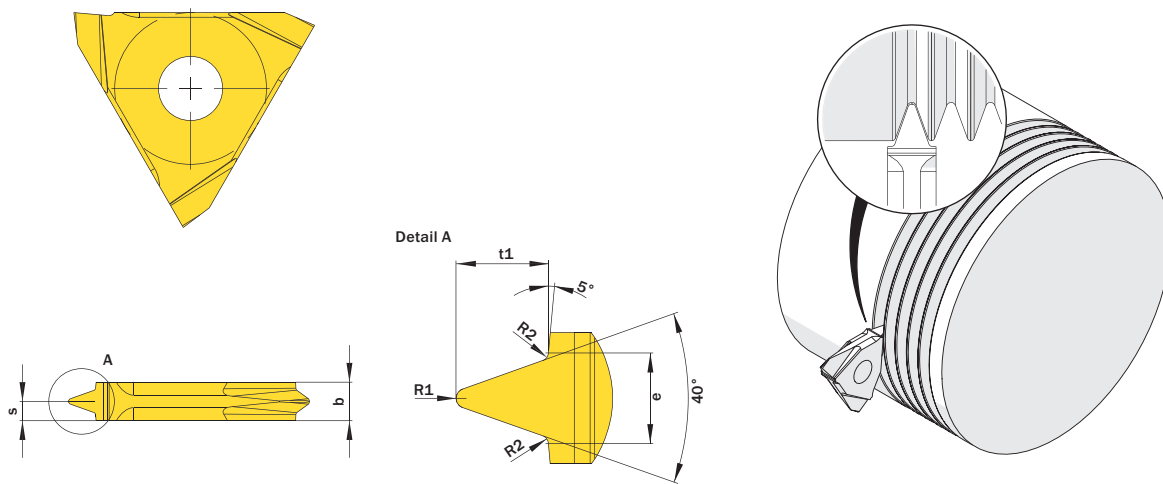


Abbildung zeigt / Drawing shows: E12.0223.30 J

e	R1	R2	b ±0,02	Artikelnummer Part number	Webcode www.simtek.com/webcode	Unsere erste Wahl Our first choice	Profil Profile	s	t1	Connectcode www.simtek.com/code
mm	mm	mm	mm			P K M N S		mm	mm	
2,34	0,25	0,2	3,3	E12.0223.30 J	ADQ4	X800 X600	J	1,65	2,3	E12.C3
3,56	0,35	0,25	4,3	E12.0356.43 J	AFAV	X800 X600	K	2,15	3,69	E12.D4

Bestellbeispiel // Order example: **E12.0356.43 J X800** (X800 = Schneidstoff // Grade)

Info

Legende Legend

- SP** Schneidwerkzeug aus CBN // CBN insert // Outils coupants en CBN // Insetto CBN
- CBN** Insetto CBN // CBN kesici uç
- SP** Schneidwerkzeug aus Hartmetall // Carbide insert // Outils coupants en carbure de tungstène // Insetto in metallo duro
- HM** Insetto de carburo // Karbür kesici uç
- TW** Trägerwerkzeug aus Stahl // Steel toolholder // Porte-outils en acier // Porta inserto in acciaio
- ST** Porta-herramientas de acero // Çelik tutucu
- R** Rechts wie gezeichnet // Right hand version shown, left hand version inversely // A droite comme présenté // In figura utensile destro
Modelo derecho // Sağ model
- LM** Speziell für Leichtmetall // For light-alloys // Pour métaux légers // Per metallo leggero
Para aleaciones ligeras // Hafif alaşımli metallər

simturn AX

simturn DX

simturn PX

simturn H2

simturn K2

simturn C4

simturn GX

simturn E3

simturn E12

simturn FX

simturn
Decolletage

simturn OA

Index

389

Index

simturn E12 Produktverzeichnis
simturn E12 Product List

Artikelnr. // Part Nr.	S/P	Artikelnr. // Part Nr.	S/P	Artikelnr. // Part Nr.	S/P	Artikelnr. // Part Nr.	S/P	Artikelnr. // Part Nr.	S/P
E09.2020.02 L	365	E12.0215.00 G	371	E12.1080.27 E L	385	E30.0032.01 L	364	E60.3232.03 L	362
E09.2020.02 R	365	E12.0215.00 GU	374	E12.1080.27 E R	385	E30.0032.01 R	364	E60.3232.03 R	362
E09.2020.03 L	365	E12.0215.11 K	373	E12.1085.00 Z	369	E30.0032.02 L	364	E60.3232.04 L	362
E09.2020.03 R	365	E12.0215.40 C	375	E12.1090.00 Z	369	E30.0032.02 R	364	E60.3232.04 R	362
E09.2020.04 L	365	E12.0223.30 J	388	E12.1094.00 Z	369	E30.0032.03 L	364	E68.1212.08 L	366
E09.2020.04 R	365	E12.0238.00 G	372	E12.1100.00 Z	369	E30.0032.03 R	364	E68.1212.08 R	366
E09.2525.02 L	365	E12.0238.12 V	381	E12.1100.27 E L	385	E30.0032.04 L	364	E68.1212.11 L	366
E09.2525.02 R	365	E12.0250.00 N	378	E12.1100.27 E R	385	E30.0032.04 R	364	E68.1212.11 R	366
E09.2525.03 L	365	E12.0250.02 N	378	E12.1102.25 F	376	E30.0040.01 L	364	E68.1616.11 L	366
E09.2525.03 R	365	E12.0250.04 N	378	E12.1103.25 F	376	E30.0040.01 R	364	E68.1616.11 R	366
E09.2525.04 L	365	E12.0250.12 V	381	E12.1104.25 F	376	E30.0040.02 L	364	E69.2020.01 L	363
E09.2525.04 R	365	E12.0265.00 G	371	E12.1105.00 Z	369	E30.0040.02 R	364	E69.2020.01 R	363
E09.3232.02 L	365	E12.0265.00 GU	374	E12.1105.25 F	376	E30.0040.03 L	364	E69.2020.02 L	363
E09.3232.02 R	365	E12.0265.11 K	373	E12.1115.00 Z	369	E30.0040.03 R	364	E69.2020.02 R	363
E09.3232.03 L	365	E12.0265.40 C	375	E12.1125.27 E L	385	E30.0040.04 L	364	E69.2020.03 L	363
E09.3232.03 R	365	E12.0300.00 N	379	E12.1125.27 E R	385	E30.0040.04 R	364	E69.2020.03 R	363
E09.3232.04 L	365	E12.0300.02 N	379	E12.1150.37 E L	385	E60.0.500.01 L	361	E69.2020.04 L	363
E09.3232.04 R	365	E12.0300.04 N	379	E12.1150.37 E R	385	E60.0.500.01 R	361	E69.2020.04 R	363
E12.0008.00 V	383	E12.0300.06 N	379	E12.1175.37 E L	385	E60.0.500.02 L	361	E69.2525.01 L	363
E12.0009.00 V	383	E12.0300.08 N	379	E12.1175.37 E R	385	E60.0.500.02 R	361	E69.2525.01 R	363
E12.0010.20 V	382	E12.0300.15 V	381	E12.1200.53 E L	385	E60.0.500.03 L	361	E69.2525.02 L	363
E12.0011.00 V	383	E12.0315.00 G	371	E12.1200.53 E R	385	E60.0.500.03 R	361	E69.2525.02 R	363
E12.0012.24 V	382	E12.0315.00 GU	374	E12.1210.00 P L	386	E60.0.500.23 L	361	E69.2525.03 L	363
E12.0014.00 V	383	E12.0315.11 K	373	E12.1210.00 P R	386	E60.0.500.23 R	361	E69.2525.03 R	363
E12.0015.30 V	382	E12.0315.40 C	375	E12.1210.11 P L	386	E60.1212.01 L	361	E69.2525.04 L	363
E12.0018.00 V	383	E12.0318.00 G	372	E12.1210.11 P R	386	E60.1212.01 R	361	E69.2525.04 R	363
E12.0020.40 V	382	E12.0356.43 J	388	E12.1250.53 E L	385	E60.1212.02 L	361	TOA.E60.19.01 L	367
E12.0025.44 W	380	E12.0400.00 N	379	E12.1250.53 E R	385	E60.1212.02 R	361	TOA.E60.19.01 R	367
E12.0025.50 V	382	E12.0400.02 N	379	E12.1300.63 E L	385	E60.1212.03 L	361	TOA.E60.19.02 L	367
E12.0030.60 V	382	E12.0400.04 N	379	E12.1300.63 E R	385	E60.1212.03 R	361	TOA.E60.19.02 R	367
E12.0050.00 H	370	E12.0400.08 N	379	E12.1302.00 V	384	E60.1212.23 L	361	TOA.E60.19.03 L	367
E12.0060.00 H	370	E12.0400.12 N	379	E12.1302.05 V	384	E60.1212.23 R	361	TOA.E60.19.03 R	367
E12.0070.00 H	370	E12.0400.20 V	381	E12.1303.00 V	384	E60.1616.01 L	361	TOA.E60.19.04 L	367
E12.0080.00 H	370	E12.0415.00 G	371	E12.1304.00 V	384	E60.1616.01 R	361	TOA.E60.19.04 R	367
E12.0090.00 H	370	E12.0415.00 GU	374	E12.1305.00 V	384	E60.1616.02 L	361	TOA.E60.19.23 L	367
E12.0100.00 H	370	E12.0415.40 C	375	E12.1306.00 V	384	E60.1616.02 R	361	TOA.E60.19.23 R	367
E12.0100.00 N	378	E12.0515.00 G	371	E12.1306.25 F	376	E60.1616.03 L	361	TOG.K.E12.C1.01 R	368
E12.0100.02 N	378	E12.0515.00 GU	374	E12.1520.11 P L	386	E60.1616.03 R	361		
E12.0100.05 V	381	E12.0515.40 C	375	E12.1520.11 P R	386	E60.1616.04 L	361		
E12.0110.00 G	371	E12.0516.00 P L	386	E12.1607.33 F	376	E60.1616.04 R	361		
E12.0110.00 GU	374	E12.0516.00 P R	386	E12.1608.33 F	376	E60.1616.23 L	361		
E12.0110.11 K	373	E12.0516.11 P L	386	E12.1609.33 F	376	E60.1616.23 R	361		
E12.0110.40 C	375	E12.0516.11 P R	386	E12.1810.33 F	376	E60.2020.01 L	361		
E12.0117.00 G	372	E12.0516.68 P S L	386	E12.1812.33 F	376	E60.2020.01 R	361		
E12.0120.06 V	381	E12.0516.68 P S R	386	E12.2015.02 A L	387	E60.2020.02 L	361		
E12.0130.00 G	371	E12.0516.68 P T L	386	E12.2015.02 A R	387	E60.2020.02 R	361		
E12.0130.00 GU	374	E12.0516.68 P T R	386	E12.2115.43 F	376	E60.2020.03 L	361		
E12.0130.11 K	373	E12.0520.00 P L	386	E12.2516.33 F	377	E60.2020.03 R	361		
E12.0130.40 C	375	E12.0520.00 P R	386	E12.2616.43 F	377	E60.2020.04 L	361		
E12.0142.00 G	372	E12.0520.11 P L	386	E12.2617.43 F	377	E60.2020.04 R	361		
E12.0150.00 N	378	E12.0520.11 P R	386	E12.3020.02 A L	387	E60.2020.23 L	361		
E12.0150.02 N	378	E12.0521.11 P L	386	E12.3020.02 A R	387	E60.2020.23 R	361		
E12.0150.07 V	381	E12.0521.11 P R	386	E12.3030.02 A L	387	E60.2525.01 L	362		
E12.0157.00 G	372	E12.0613.11 P L	386	E12.3030.02 A R	387	E60.2525.01 R	362		
E12.0160.00 G	371	E12.0613.11 P R	386	E12.3118.53 F	377	E60.2525.02 L	362		
E12.0160.00 GU	374	E12.1034.00 Z	369	E12.4120.53 F	377	E60.2525.02 R	362		
E12.0160.11 K	373	E12.1044.00 Z	369	E12.4125.53 F	377	E60.2525.03 L	362		
E12.0160.40 C	375	E12.1050.00 Z	369	E12.5130.63 F	377	E60.2525.03 R	362		
E12.0185.00 G	371	E12.1050.17 E L	385	E30.0025.01 L	364	E60.2525.04 L	362		
E12.0185.00 GU	374	E12.1050.17 E R	385	E30.0025.01 R	364	E60.2525.04 R	362		
E12.0185.11 K	373	E12.1054.00 Z	369	E30.0025.02 L	364	E60.2525.23 L	362		
E12.0185.40 C	375	E12.1060.00 Z	369	E30.0025.02 R	364	E60.2525.23 R	362		
E12.0200.00 N	378	E12.1064.00 Z	369	E30.0025.03 L	364	E60.3232.01 L	362		
E12.0200.02 N	378	E12.1070.00 Z	369	E30.0025.03 R	364	E60.3232.01 R	362		
E12.0200.04 N	378	E12.1074.00 Z	369	E30.0025.04 L	364	E60.3232.02 L	362		
E12.0200.10 V	381	E12.1080.00 Z	369	E30.0025.04 R	364	E60.3232.02 R	362		

Das Werkzeugsystem im Überblick
The Tool System Overview

Kompromisslose Leistung für besondere Anwendungen. Performance without compromise for special applications.

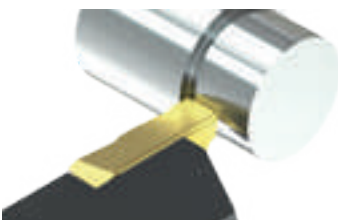
Alle Anwendungen auf einen Blick // All applications at one glance

Längsdrehen · Konturdrehen · Rückwärtsdrehen · Einstechen · Axial Gewindefreistriche
Turning · Profiling · Back Turning · Grooving and Profiling · Face Thread Reliefs

Detaillierte Übersicht aller Anwendungen ab Seite 393
Detailed overview of all applications as of page 393

Hauptanwendungen // Main Applications

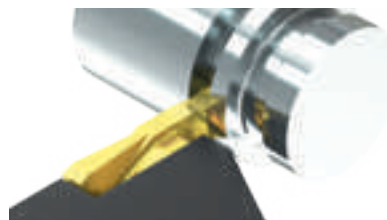
Längsdrehen Turning



Präzisionsgeschliffene Wendeschneidplatten für das Längsdrehen mit spezieller Spantreppe für optimale Leistung und Spanbildung. Auch für das Rückwärtsdrehen bzw. Längsdrehen „hinter Bund“ verfügbar.

Precision-ground indexable inserts for turning applications with special chip breaking geometry for optimum performance and chip formation. Also available for back turning „behind shoulder“.

Einstechen und Profildrehen Grooving and Profiling



Große Auswahl an Wendeschneidplatten für das Einstechen und Profildrehen. Schneidenbreiten zwischen 1,0 mm und 5,0 mm und verschiedenen Schneidengeometrien für optimale Ergebnisse und Spankontrolle.

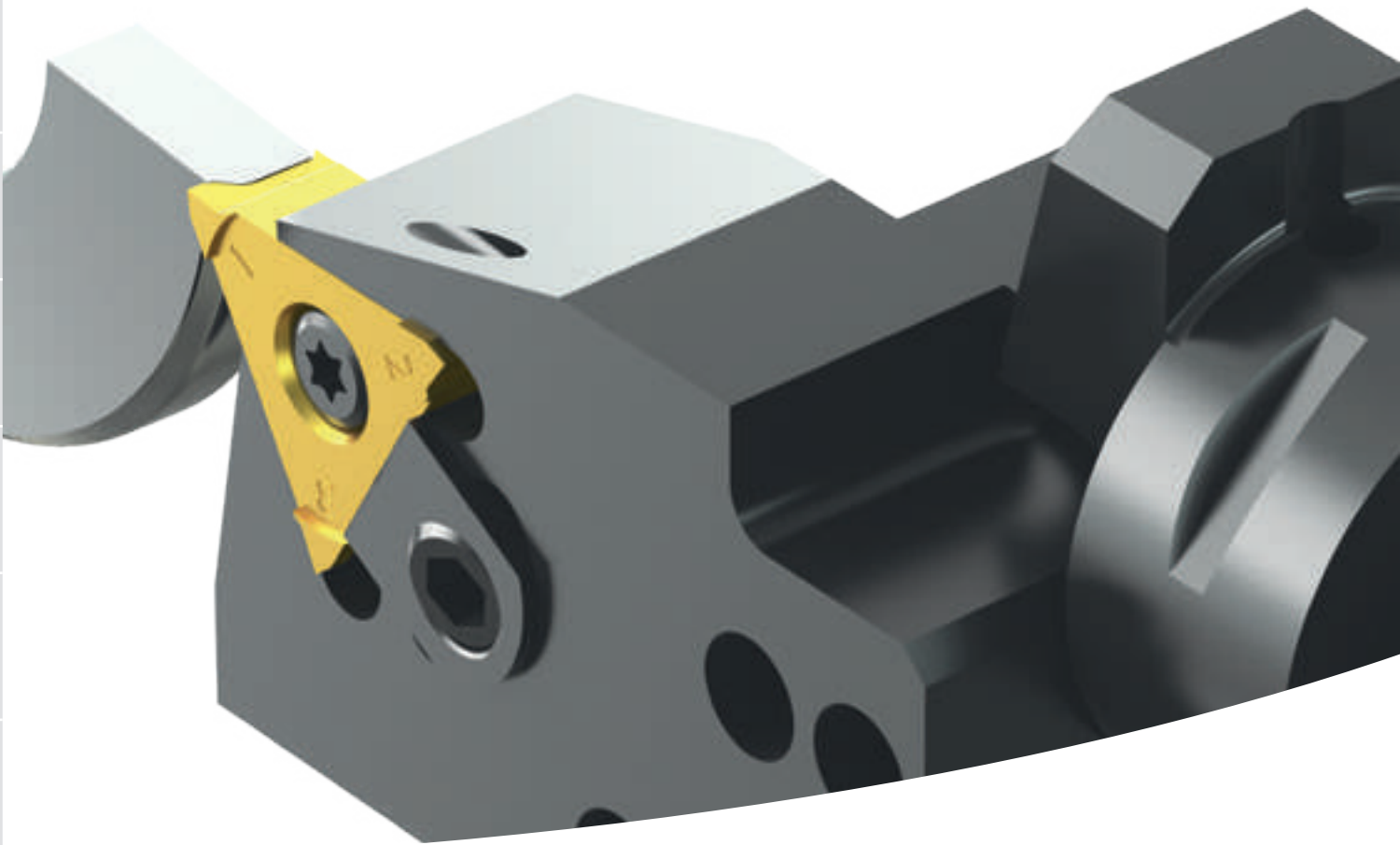
Wide range of indexable inserts for grooving and profiling applications. Cutting edge widths between 1.0 mm and 5.0 mm and various cutting edge geometries for optimum results and chip control.

Individualwerkzeuge Customized tools



Aufgrund seiner stabilen und vielseitig bearbeitbaren Bauform bietet das Werkzeugsystem simturn FX eine ideale Grundlage für Individualwerkzeuge, welche perfekt an die spezifischen Anforderungen Ihres Bauteils angepasst werden können.

Based on its stable and versatile machineable design, the tool system simturn FX offers an ideal basis for individual tools that can be perfectly adapted to the specific requirements of your component.



Für kundenindividuelle Anforderungen an höchste Präzision, Wiederholgenauigkeit, Leistung und Stabilität bieten wir mit diesen Werkzeugsystemen eine passende Lösung.

Dreischneidige, vollständig präzisionsgeschliffene Wendeschneidplatte für Standard- und Sonderanwendungen. Umfangreiche Auswahl an Standardträgerwerkzeugen und wenn das passende nicht dabei sein sollte, ist auch das Trägerwerkzeug als Sonderausführung verfügbar.

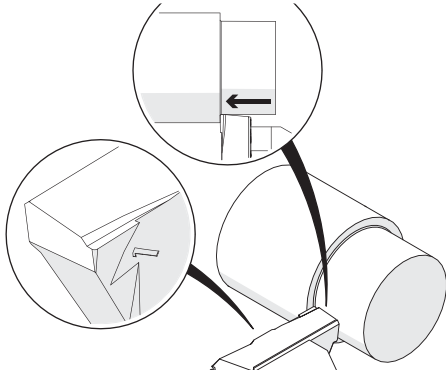
These systems are the first choice for individual needs towards highest precision, repeatability, performance and stability - without compromise.

Triple-edged, fully ground and indexable carbide cutting insert for standard- and special applications. Wide range of standard toolholders – and a matching special solution in case there is no standard given.

Standardanwendungen Standard Applications

Ab Seite
As of Page

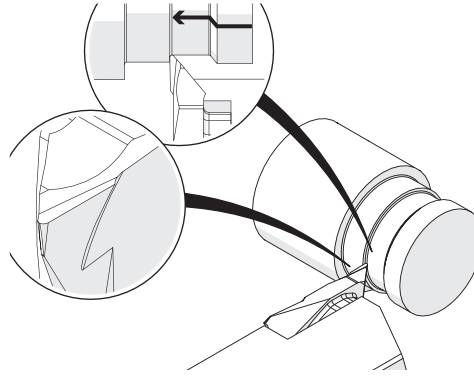
402



Längsdrehen
Turning

Seite
Page

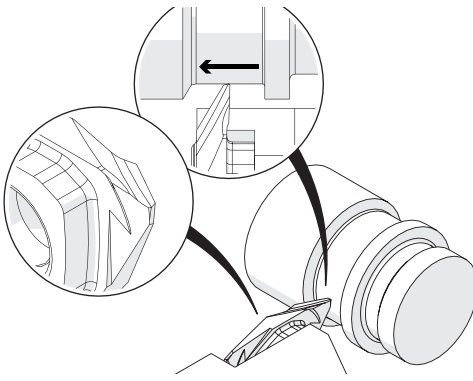
403



Längs- und Konturdrehen
Turning and Profiling

Seite
Page

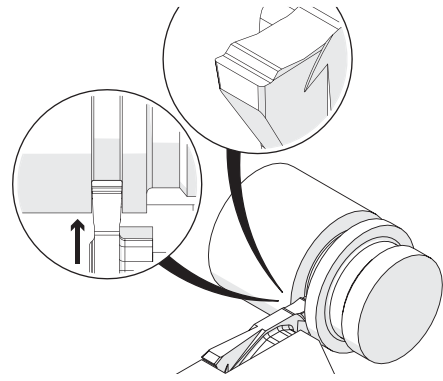
404



Rückwärtsdrehen
Back Turning

Ab Seite
As of Page

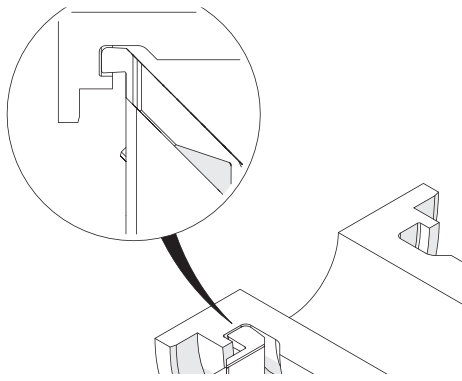
406



Einstechdrehen
Grooving and Profiling

Seite
Page

409



Axial Gewindefreistriche
Face Thread Reliefs

Klemmhalter, Außenbearbeitung, Typ A

Trägerschaft für die Außenbearbeitung, bei Formbreiten bis etwa 6,0 mm.

Toolholder, External Applications, Type A

Toolholder for external applications and form widths up to 6,0 mm.

Anzugsmoment (Schraube) // Tightening torque (screw)

"F M5x11,5 T20R": 6,0 Nm
"F M5x12 T20R": 6,0 Nm
"F M5x13 T20R": 6,0 Nm

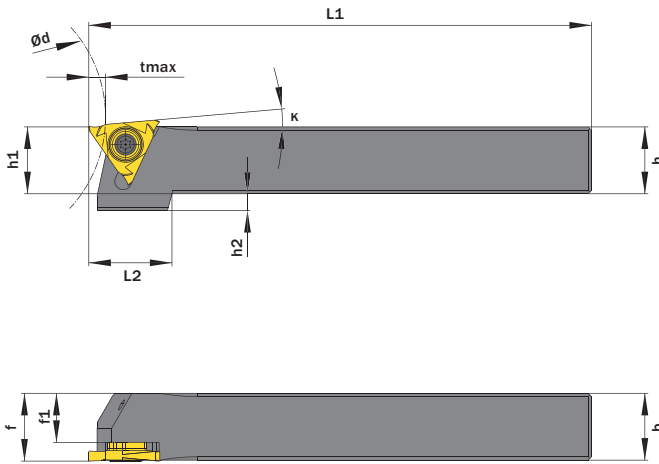


Legende
Legend **410**



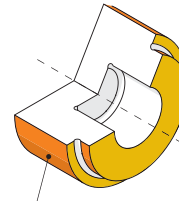
Scan
QR-Code

Oder besuchen Sie // Or Visit
www.simtek.info/cp/619



tmax in Abhängigkeit vom Werkstückdurchmesser (Ød)
tmax depends on workpiece diameter (Ød)

workpiece diameter (Ød)	tmax
Bis Ø63,0 mm / up to Ø2.4803"	5,5 mm / 0.2165"
Bis Ø80,0 mm / up to Ø3.1496"	5,0 mm / 0.1969"
Bis Ø100,0 mm / up to Ø3.9370"	5,0 mm / 0.1969"
Bis Ø160,0 mm / up to Ø6.2992"	4,5 mm / 0.1772"
Bis Ø200,0 mm / up to Ø7.8740"	4,0 mm / 0.1575"



- Hauptsächlich geeignet für diese Flächen
Mainly designed for these surfaces
- Je nach Schneidplatte/Aufnahme ebenfalls möglich
Also possible depending on insert/fixation type

Abbildung zeigt / Drawing shows: TF3.50.2020.A.12.00 R

K	h	b	L1	Artikelnummer Part number	Webcode www.simtek.com/webcode	f	f1	h1 ^{js14}	h2	L2	Schraube Screw	Schraubenschlüssel Screw driver	Connectcode www.simtek.com/code
▼ h = 12,0 mm													
0°	12,0	12,0	100,0	TF3.01.1212.A.10.00 R/L	R AXU9 L AXU8	12,4	6,9	12,0	9,0	24,0	F M5x11,5 T20R	T20R	R TF3.R.01.00 L TF3.L.01.00 ^{upd}
▼ h = 15,875 mm													
0°	15,875	15,875	125,0	TF3.01.0.625.A.12.00 R	A33K	16,3	10,78	15,9	9,1	24,0	F M5x12 T20R	T20R	TF3.R.01.00 ^{new}
▼ h = 16,0 mm													
0°	16,0	16,0	125,0	TF3.01.1616.A.12.00 R/L	R AWC5 L AWC4	16,4	10,9	16,0	9,0	24,0	F M5x13 T20R	T20R	R TF3.R.01.00 L TF3.L.01.00
0°	16,0	16,0	125,0	TF3.01.1616.A.12.08 R/L	R AZF5 L AZF4	16,4	8,55	16,0	9,0	24,0	F M5x13 T20R	T20R	R TF3.R.01.08 L TF3.L.01.08
▼ h = 20,0 mm													
0°	20,0	20,0	125,0	TF3.01.2020.A.12.00 R/L	R AWC7 L AWC6	20,4	14,9	20,0	5,0	24,0	F M5x13 T20R	T20R	R TF3.R.01.00 L TF3.L.01.00
0°	20,0	20,0	125,0	TF3.01.2020.A.12.08 R/L	R AWNU L AWNV	20,4	12,55	20,0	5,0	24,0	F M5x13 T20R	T20R	R TF3.R.01.08 L TF3.L.01.08
0°	20,0	20,0	125,0	TF3.01.2020.A.12.10 R/L	R AWNX L AWNW	20,4	9,6	20,0	5,0	24,0	F M5x13 T20R	T20R	R TF3.R.01.10 L TF3.L.01.10
▼ h = 25,0 mm													
0°	25,0	25,0	150,0	TF3.01.2525.A.15.00 R/L	R AWC9 L AWC8	25,4	19,9	25,0	-	-	F M5x13 T20R	T20R	R TF3.R.01.00 L TF3.L.01.00
0°	25,0	25,0	150,0	TF3.01.2525.A.15.08 R/L	R AZ5C L AZ5D	25,4	17,55	25,0	-	-	F M5x13 T20R	T20R	R TF3.R.01.08 L TF3.L.01.08
▼ h = 25,4 mm													
0°	25,4	25,4	150,0	TF3.01.1.000.A.15.00 R	A3X7	25,8	20,3	25,4	-	-	F M5x13 T20R	T20R	TF3.R.01.00 ^{new}

■ Bestellbeispiel // Order example: **TF3.01.2020.A.12.00 R** (R = Rechte Ausführung // Right hand version)

- Connectcode TF3.R.01.08 | TF3.L.01.08 | TF3.R.01.10 | TF3.L.01.10 sind für Individual-Schneidwerkzeuge vorgesehen.
- Connectcode TF3.R.01.08 | TF3.L.01.08 | TF3.R.01.10 | TF3.L.01.10 are provided for customized cutting tools.

Klemmhalter, Außenbearbeitung, Gekröpft, Typ D

Trägerschaft für die Außenbearbeitung, 45° und 90° gekröpft Ausführung.

Toolholder, For External Application, Cranked, Type D

Toolholder for external applications. 45° and 90° cranked style.

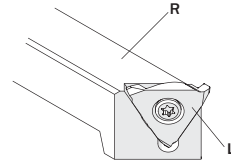
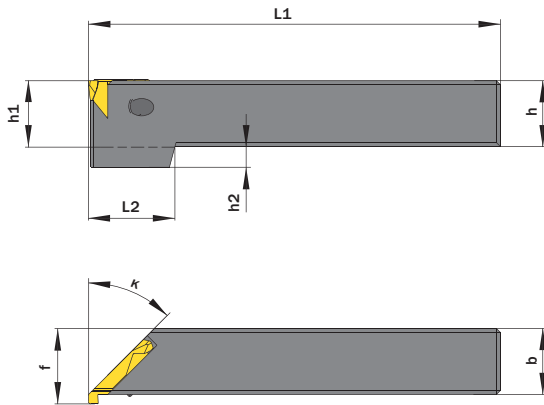
Anzugsmoment (Schraube) // Tightening torque (screw)

"F M5x13 T20R": 6,0 Nm
"M M5x0,5x7,5 T20R": 6,0 Nm

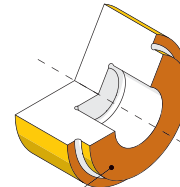


Legende Legend 410

Scan QR-Code Oder besuchen Sie // Or Visit www.simtek.info/cp/940



Bitte beachten: Rechter Halter wird mit linker Platte bestückt und umgekehrt. Please use right hand toolholder with left hand insert and vice versa.



- Hauptsächlich geeignet für diese Flächen
Mainly designed for these surfaces
- Je nach Aufnahmetyp ebenfalls möglich
Also possible depending on fixation type

TF3.51.2020.D.90.12.00 R

Abbildung zeigt / Drawing shows: TF3.00.1616.D.45.10.00 R

h	b	κ	L1	Artikelnummer Part number	Webcode www.simtek.com/webcode	f	h1 ^{js14}	h2	L2	Schraube Screw	Schraubenschlüssel Screw driver	Connectcode www.simtek.com/code	
mm	mm		mm			mm	mm	mm	mm				
▼ κ = 45°													
15,875	15,875	45°	100,0	TF3.00.062S.D.45.10.00 R	A4XF	18,2	15,9	5,1	21,0	M M5x0,5x7,5 T20R	T20R	TF3.R.45.00.03	new
19,05	19,05	45°	125,0	TF3.00.075S.D.45.12.00 R	A4P9	21,4	19,0	6,0	21,0	M M5x0,5x7,5 T20R	T20R	TF3.R.45.00.03	new
25,4	25,4	45°	150,0	TF3.00.100S.D.45.15.00 R	A4QB	27,7	25,4	-	-	M M5x0,5x7,5 T20R	T20R	TF3.R.45.00.03	new
16,0	16,0	45°	100,0	TF3.00.1616.D.45.10.00 R/L	A4P9 L A4PN	18,3	16,0	5,0	21,0	M M5x0,5x7,5 T20R	T20R	R TF3.R.45.00.03 L TF3.L.45.00.03	new
20,0	20,0	45°	125,0	TF3.00.2020.D.45.12.00 R/L	A4P9 L A4PQ	22,3	20,0	5,0	21,0	M M5x0,5x7,5 T20R	T20R	R TF3.R.45.00.03 L TF3.L.45.00.03	new
25,0	25,0	45°	150,0	TF3.00.2525.D.45.15.00 R/L	A4P9 L A4PT	27,3	25,0	-	-	M M5x0,5x7,5 T20R	T20R	R TF3.R.45.00.03 L TF3.L.45.00.03	new
▼ κ = 90°													
25,4	25,4	90°	150,0	TF3.01.100S.D.90.15.00 R/L	A6VD L A6VB	32,4	25,4	-	-	F M5x13 T20R	T20R	R TF3.L.51.00 TF3.R.51.00 L TF3.L.51.00 TF3.R.51.00	new
20,0	20,0	90°	125,0	TF3.01.2020.D.90.12.00 R/L	A6VH L A6VF	27,0	20,0	-	-	F M5x13 T20R	T20R	R TF3.L.51.00 TF3.R.51.00 L TF3.L.51.00 TF3.R.51.00	new
25,0	25,0	90°	150,0	TF3.01.2525.D.90.15.00 R/L	A6VN L A6VK	32,0	25,0	-	-	F M5x13 T20R	T20R	R TF3.L.51.00 TF3.R.51.00 L TF3.L.51.00 TF3.R.51.00	new

Bestellbeispiel // Order example: **TF3.00.2020.D.45.12.00 R** (R = Rechte Ausführung // Right hand version)

Connectcode TF3.R.51.00 und TF3.L.51.00 sind für Individual-Schneidwerkzeuge vorgesehen.

Connectcode TF3.R.51.00 und TF3.L.51.00 are provided for customized cutting tools.

Drehbearbeitung außen // External Grooving and Turning
 simturn F3 > Trägerwerkzeug // Toolholder



Klemmhalter, Außenbearbeitung, Typ A, mit verstellbarer Kühlmitteldüse

Trägerschaft für die Außenbearbeitung. Mit verstellbarer Kühlmitteldüse zur optimalen Kühlung je nach Anwendungsfall und drei nutzbaren Anschlussgewinden für die Kühlmittelzufuhr.

Toolholder, External Applications, Type A, with adjustable coolant nozzle

Toolholder for external applications. With adjustable coolant nozzle for an optimized cooling according to the application and three usable connection threads for the coolant supply.

Anzugsmoment (Schraube) // Tightening torque (screw)

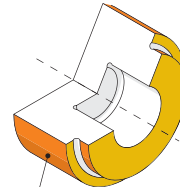
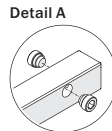
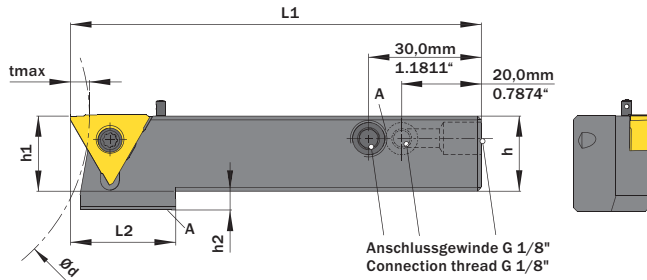
"F M5x11,5 T20R": 6,0 Nm
 "F M5x13 T20R": 6,0 Nm



Legende Legend 410



Oder besuchen Sie // Or Visit www.simtek.info/cp/1192



tmax in Abhängigkeit vom Werkstückdurchmesser (Ød)
 tmax depends on Workpiece diameter (Ød)

Workpiece diameter (Ød)	tmax
Bis Ø63,0 mm / up to Ø2.4803"	5,5 mm / 0.2165"
Bis Ø80,0 mm / up to Ø3.1496"	5,0 mm / 0.1969"
Bis Ø100,0 mm / up to Ø3.9370"	5,0 mm / 0.1969"
Bis Ø125,0 mm / up to Ø4.9213"	4,5 mm / 0.1772"
Bis Ø160,0 mm / up to Ø6.2992"	4,5 mm / 0.1772"
Bis Ø200,0 mm / up to Ø7.8740"	4,0 mm / 0.1575"

Kühlmitteldüse / Coolant nozzle
 TOC.A.5X13.PIN IC

- Hauptsächlich geeignet für diese Flächen
 Mainly designed for these surfaces
- Je nach Schneidplatte/Aufnahme ebenfalls möglich
 Also possible depending on insert/fixation type

Abbildung zeigt / Drawing shows: TF3.01.2020.A.10.00 CG R

K	h	b	L1	Artikelnummer Part number	Webcode www.simtek.com/webcode	f	f1	h1 ^{js14}	h2	L2	Schraube Screw	Schraubenschlüssel Screw driver	Connectcode www.simtek.com/code
▼ h = 12,0 mm													
0°	12,0	12,0	100,0	TF3.01.1212.A.10.00 CG R/L	R AZGB L AZGA	12,4	6,9	12,0	9,0	28,0	F M5x11,5 T20R	T20R	R TF3.R.01.00 L TF3.L.01.00
▼ h = 16,0 mm													
0°	16,0	16,0	100,0	TF3.01.1616.A.10.00 CG R/L	R AZGD L AZGC	16,4	10,9	16,0	9,0	28,0	F M5x13 T20R	T20R	R TF3.R.01.00 L TF3.L.01.00
▼ h = 19,05 mm													
0°	19,05	19,05	100,0	TF3.01.075S.A.10.08 CG R	A4YN	19,4	12,55	19,0	6,0	28,0	F M5x13 T20R	T20R	TF3.R.01.08 new
▼ h = 20,0 mm													
0°	20,0	20,0	100,0	TF3.01.2020.A.10.00 CG R/L	R AZGF L AZGE	20,4	14,9	20,0	5,0	28,0	F M5x13 T20R	T20R	R TF3.R.01.00 L TF3.L.01.00
0°	20,0	20,0	100,0	TF3.01.2020.A.10.08 CG R/L	R AZGH L AZGG	20,4	12,55	20,0	5,0	28,0	F M5x13 T20R	T20R	R TF3.R.01.08 L TF3.L.01.08
0°	20,0	20,0	100,0	TF3.01.2020.A.10.10 CG R/L	R AZGK L AZGJ	20,4	9,6	20,0	5,0	28,0	F M5x13 T20R	T20R	R TF3.R.01.10 L TF3.L.01.10
▼ h = 25,0 mm													
0°	25,0	25,0	100,0	TF3.01.2525.A.10.00 CG R/L	R AZGN L AZGM	25,4	19,9	25,0	-	-	F M5x13 T20R	T20R	R TF3.R.01.00 L TF3.L.01.00
0°	25,0	25,0	100,0	TF3.01.2525.A.10.08 CG R/L	R A1QK L A1S9	25,4	17,55	25,0	-	-	F M5x13 T20R	T20R	R TF3.R.01.08 L TF3.L.01.08
▼ h = 25,4 mm													
0°	25,4	25,4	100,0	TF3.01.100S.A.10.08 CG R	A4YK	25,8	17,95	25,4	-	-	F M5x13 T20R	T20R	TF3.R.01.08 new
0°	25,4	25,4	100,0	TF3.01.100S.A.10.10 CG R	A42K	25,8	15,0	25,4	-	-	F M5x13 T20R	T20R	TF3.R.01.10 new

Bestellbeispiel // Order example: TF3.01.075S.A.10.08 CG R (R = Rechte Ausführung // Right hand version)

Connectcode TF3.R.01.08 | TF3.L.01.08 | TF3.R.01.10 | TF3.L.01.10 sind für Individual-Schneidwerkzeuge vorgesehen.

Connectcode TF3.R.01.08 | TF3.L.01.08 | TF3.R.01.10 | TF3.L.01.10 are provided for customized cutting tools.

Kassette für Modulares Werkzeugsystem TOA

Geeignet für SIMTEK Grundhalter mit Polygonschaft nach ISO 26623.

Cassette for Modular Tool System TOA

For use on SIMTEK base toolholder with polygon shank according to ISO 26623.

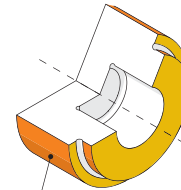
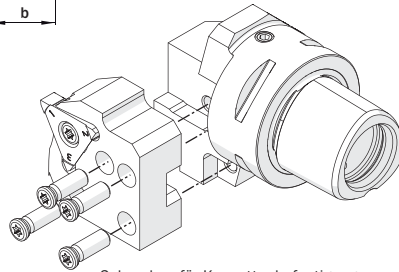
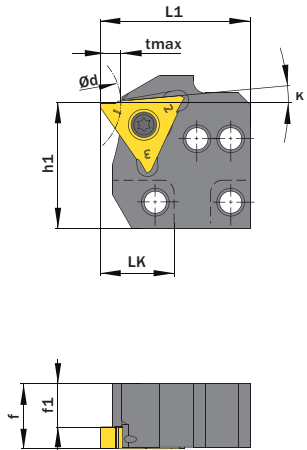
Anzugsmoment (Schraube) // Tightening torque (screw)

6,0 Nm



Legende
 Legend **410**

Scan QR-Code Oder besuchen Sie // Or Visit www.simtek.info/cp/1190



Schrauben für Kassettenbefestigung
 Screw for cassette mounting
T M5x15 T20R

- Hauptsächlich geeignet für diese Flächen
 Mainly designed for these surfaces
- Je nach Schneidplatte/Aufnahme ebenfalls möglich
 Also possible depending on insert/fixation type

Abbildung zeigt / Drawing shows: TOA.TF3.50.A.19.05 R

κ	LK mm	Artikelnummer Part number	Webcode www.simtek.com/webcode	b mm	ød mm	f mm	f1 mm	h1 mm	L1 mm	tmax mm	Schraube Screw	Schraubenschlüssel Screw driver	Connectcode www.simtek.com/code	Adaptcode Adaptcode
0°	19,0	TOA.TF3.00.A.19.05 R/L	R AY97 L AZAS	16,0	100,0	16,4	10,9	31,6	37,9	5,0	F M5x13 T20R	T20R	R TF3.R.00.00 L TF3.L.00.00	TOA R/L
0°	19,0	TOA.TF3.01.A.19.05 R/L	R AY55 L AZBQ	16,0	100,0	16,4	10,9	31,6	37,9	5,0	F M5x13 T20R	T20R	R TF3.R.01.00 L TF3.L.01.00	TOA R/L
0°	29,0	TOA.TF3.01.A.29.05 R/L	R AZBT L AZBS	16,0	100,0	16,4	10,9	31,6	37,9	5,0	F M5x13 T20R	T20R	R TF3.R.01.00 L TF3.L.01.00	TOA R/L
5°	19,0	TOA.TF3.50.A.19.05 R/L	R AZAU L AZAT	16,0	100,0	16,4	10,9	31,6	37,9	5,0	F M5x13 T20R	T20R	R TF3.R.50.00 L TF3.L.50.00	TOA R/L

Bestellbeispiel // Order example: **TOA.TF3.01.A.19.05 R** (R = Rechte Ausführung // Right hand version)

Connectcode TF3.R.00.00 | TF3.L.00.00 | TF3.R.50.00 | TF3.L.50.00 sind für Individual-Schneidwerkzeuge vorgesehen.

Connectcode TF3.R.00.00 | TF3.L.00.00 | TF3.R.50.00 | TF3.L.50.00 are provided for customized cutting tools.

Kassette für Modulares Werkzeugsystem TOA

Geeignet für SIMTEK Grundhalter mit Polygonschaft nach ISO 26623.

Cassette for Modular Tool System TOA

For use on SIMTEK base toolholder with polygon shank according to ISO 26623.

Anzugsmoment (Schraube) // Tightening torque (screw)

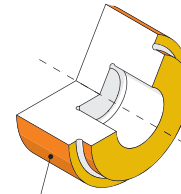
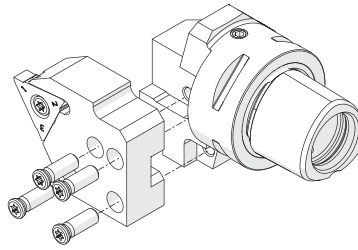
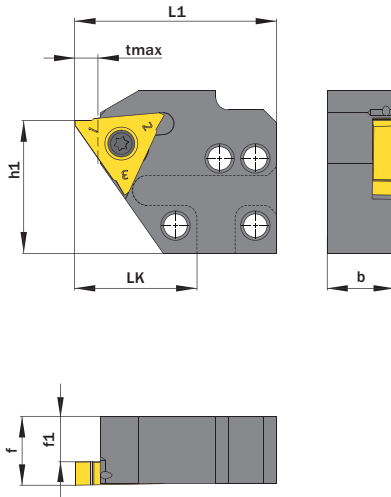
6,0 Nm



Legende
Legend **410**



Oder besuchen Sie // Or Visit
www.simtek.info/cp/1188



Schrauben für Kassettenbefestigung
Screw for cassette mounting
T M5x15 T20R

- Hauptsächlich geeignet für diese Flächen
Mainly designed for these surfaces
- Je nach Schneidplatte/Aufnahme ebenfalls möglich
Also possible depending on insert/fixation type

Abbildung zeigt / Drawing shows: TOA.TF3.51.C.29.05 R

Artikelnummer Part number	Webcode www.simtek.com/webcode	b	f	f1	h1	LK	L1	tmax	Schraube Screw	Schraubenschlüssel Screw driver	Connectcode www.simtek.com/ccode		Adaptcode Adaptcode
											R	L	
TOA.TF3.51.C.29.05 R/L	R AZAQ L AZAP	16,0	16,4	10,9	31,6	29,0	47,9	5,5	F M5x13 T20R	T20R	R TF3.R.51.00 L TF3.L.51.00	TOA R/L	

Bestellbeispiel // Order example: **TOA.TF3.51.C.29.05 R** (R = Rechte Ausführung // Right hand version)

- Kassette mit Connectcode „TF3.R.51.00“ und „TF3.L.51.00“ sind für Individual-Schneidwerkzeuge vorgesehen.
- Cassette with Connectcode „TF3.R.51.00“ and „TF3.L.51.00“ are provided for customized cutting tools.

Kassette für Modulares Werkzeugsystem TOA

Geeignet für SIMTEK Grundhalter mit Polygonschaft nach ISO 26623.

Cassette for Modular Tool System TOA

For use on SIMTEK base toolholder with polygon shank according to ISO 26623.

Anzugsmoment (Schraube) // Tightening torque (screw)

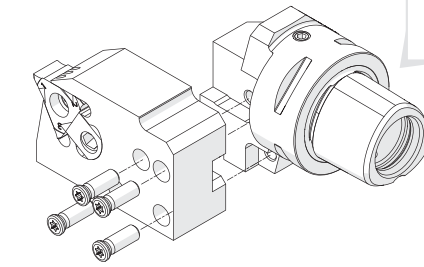
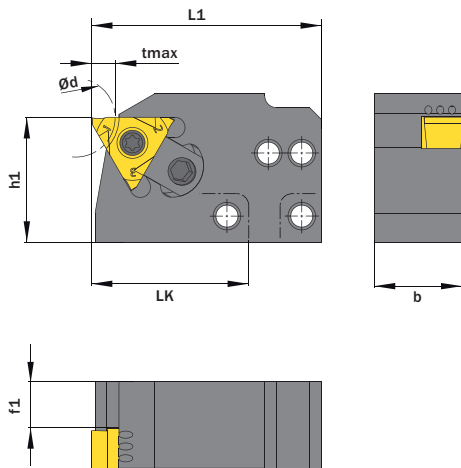
6,0 Nm



Legende
Legend **410**

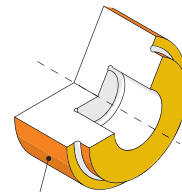
Scan QR-Code Oder besuchen Sie // Or Visit www.simtek.info/cp/1185

Grundhalter finden Sie ab Seite 425
Base toolholder can be found on page 425



Schrauben für Kassettenbefestigung
Screw for cassette mounting
T M5x15 T20R

tmax in Abhängigkeit vom Werkstückdurchmesser (Ød) tmax depends from Workpiece diameter (Ød)	
Werkstückdurchmesser (Ød) Workpiece diameter (Ød)	tmax
Bis Ø20,0 mm / up to Ø0.7874"	6,0 mm / 0.2362"
Bis Ø30,0 mm / up to Ø1.1811"	4,5 mm / 0.1772"
Bis Ø40,0 mm / up to Ø1.5748"	4,0 mm / 0.1575"
Bis Ø50,0 mm / up to Ø1.9685"	3,5 mm / 0.1378"
Bis Ø60,0 mm / up to Ø2.3622"	3,5 mm / 0.1378"
Bis Ø100,0 mm / up to Ø3.9370"	3,0 mm / 0.1181"



- Hauptsächlich geeignet für diese Flächen
Mainly designed for these surfaces
- Je nach Schneidplatte/Aufnahme ebenfalls möglich
Also possible depending on insert/fixation type

Abbildung zeigt / Drawing shows: TOA.TF3.00.B.39.10 R

Artikelnummer Part number	Webcode www.simtek.com/webcode		b	f1	h1	LK	L1	Schraube Screw	Schraubenschlüssel Screw driver	Spannelement Clamp	Connectcode www.simtek.com/code		Adaptcode Adaptcode
											R	L	
TOA.TF3.00.B.39.06 R/L	R AZAH	L AZAG	22,0	15,7	31,6	39,5	58,4	F M5x13 T20R	T20R	F22.06.11	R TF3.L.00.06	L TF3.R.00.06	TOA R/L
TOA.TF3.00.B.39.08 R/L	R AZAK	L AZAJ	22,0	13,7	31,6	39,5	58,4	F M5x13 T20R	T20R	F22.08.11	R TF3.L.00.08	L TF3.R.00.08	TOA R/L
TOA.TF3.00.B.39.10 R/L	R AZAN	L AZAM	22,0	11,7	31,6	39,5	58,4	F M5x13 T20R	T20R	F22.10.11	R TF3.L.00.10	L TF3.R.00.10	TOA R/L

Bestellbeispiel // Order example: **TOA.TF3.00.B.39.10 R** (R = Rechte Ausführung // Right hand version)

simturn AX
simturn DX
simturn PX
simturn H2
simturn H2
simturn K2
simturn C4
simturn GX
simturn E3
simturn E12
simturn FX
simturn Decolletage
simturn OA
Index

Höhenverstellbare Kassette, für Rückseitenbearbeitungen

Kassette für höhenverstellbare Rückseitenbearbeitung auf Grundhaltern-Typ „TOG“ der Marke precium.

Height-Adjustable Cassette for back operations

Cassette for height-adjustable back operations tools. Compatible to TOG-system by precium.

Anzugsmoment (Schraube) // Tightening torque (screw)

7,0 Nm



Legende
Legend **410**

Scan QR-Code

Oder besuchen Sie // Or Visit www.simtek.info/cp/1222

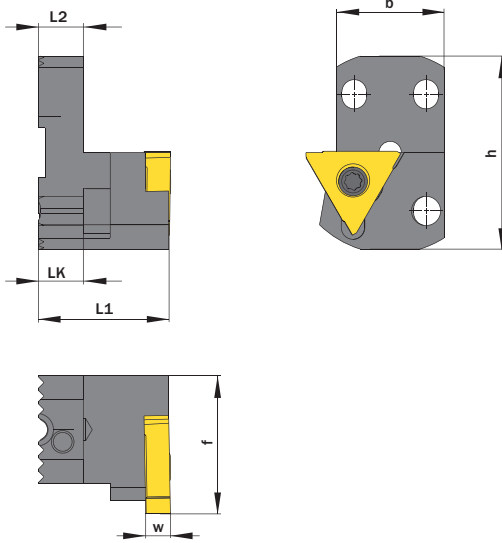


Abbildung zeigt / Drawing shows: TOG.K.TF3.01.A1 R

Mehr Informationen unter www.precium.de
 More information on www.precium.de



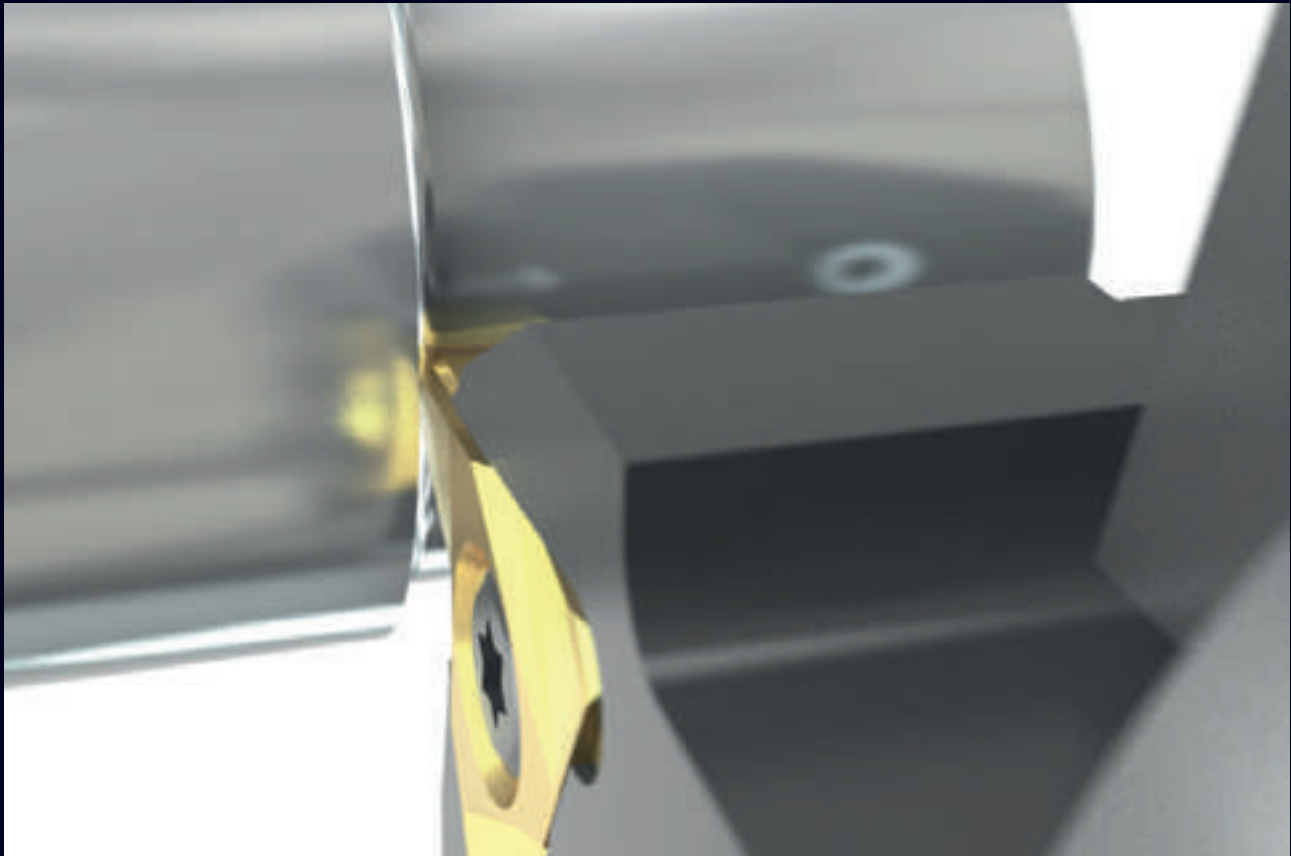
Abbildung ähnlich // Illustration only

Mit Kühlmittelzufuhr With through coolant supply	Artikelnummer Part number	Webcode www.simtek.com/webcode		b	h	f	L1	L2	LK	w	Schraube Screw	Schraubenschlüssel Screw driver	Connectcode www.simtek.com/ccode	
		R	L										R	L
Nein / No	TOG.K.TF3.01.A1 R/L	AZHN	AZHM	24,0	43,0	30,75	29,0	10,0	10,0	5,5	TF3 M5x15 T20R	T20R	TF3.R.01.00	TF3.L.01.00
Ja / Yes	TOG.K.TF3.01.B1 R/L	AZHS	AZHQ	24,0	43,0	30,75	46,0	27,0	10,0	5,5	TF3 M5x15 T20R	T20R	TF3.R.01.00	TF3.L.01.00

Bestellbeispiel // Order example: **TOG.K.TF3.01.A1 R** (R = Rechte Ausführung // Right hand version)

Individualwerkzeuge // Customized tools

Kundenindividuelle Werkzeuglösungen Customer-specific tooling solutions



Maximale Spankontrolle dank kontrolliertem Spanbruch durch die auf das bearbeitete Material abgestimmte Spantreppe.

Maximum chip control and controlled chip breaking thanks to the chip forming geometry, perfectly matched to the material to be machined.

SIMTEK Individualwerkzeuge bieten unzählige Vorteile! Neben unserem Anspruch, jeweils die qualitativ bestmögliche Werkzeuglösung für Ihre Anwendung anzubieten, ist es auch unser Bestreben Ihnen durch ein SIMTEK Individualwerkzeug den größtmöglichen wirtschaftlichen Nutzen zu liefern! Tausende, aktuell erfolgreich eingesetzte Individualwerkzeuge bestätigen dies!

SIMTEK individual tools offer countless advantages! In addition to our goal to offer the qualitatively best possible tooling solution for your application, we also aspire to provide you with the greatest possible economic benefit from a customized SIMTEK tool! Thousands of currently successfully used SIMTEK individual tools confirm this!

Kontaktieren Sie uns und lassen auch Sie sich von den Vorteilen mit SIMTEK Individualwerkzeugen überzeugen!

Contact us and convince yourself of the advantages of SIMTEK individual tools!

simturnFX
SIMTEK small part machining type FX

Längsdrehen, mit Spantreppe Typ E

Typ „E“ Spantreppe, für optimale Leistung und Spanbildung.

Turning, Cutting Edge Design „E“

Cutting edge design „E“, for high performance and chip control.

Schnittwerte (Start) // Cutting parameters (start)

f	Vc
0,08 mm/U	Seite/Page 429

Passende Klemmhalter auf Seite // Suitable toolholders on page
 394, 396, 397, 400

SP

HM

R

Legende
Legend

410

Scan
QR-Code

Oder besuchen Sie // Or Visit
www.simtek.info/cp/1018

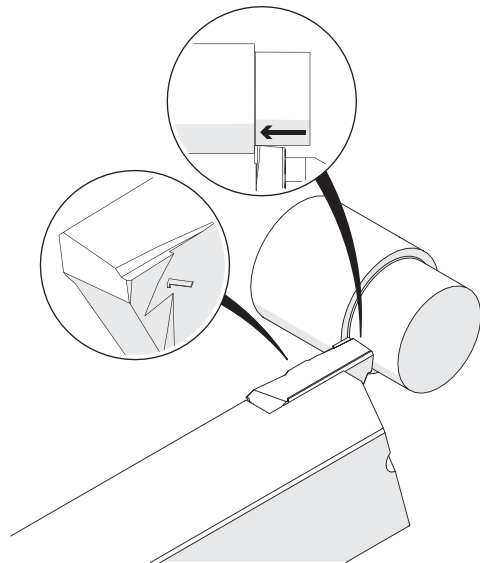
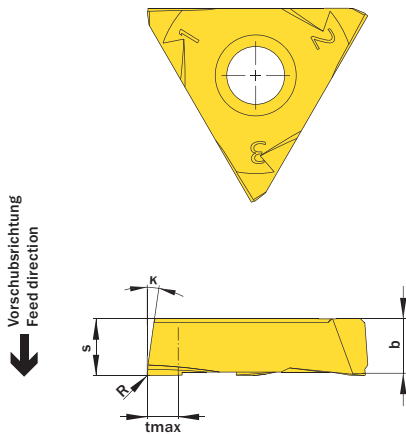


Abbildung zeigt / Drawing shows: TF3.01.008.10.020 YER

K	R	Artikelnummer Part number	Webcode www.simtek.com/webcode		Unsere erste Wahl Our first choice		b	s	tmax	Connectcode www.simtek.com/ccode	
			R	L	P	K				M	N
8°	0,2	TF3.01.008.10.020 YER/L	AWZD	AWZC	X808	X802	5,2	5,5	3,0	R TF3.R.01.00	L TF3.L.01.00
8°	0,4	TF3.01.008.10.040 YER/L	AWZF	AWZE	X600	X602	5,2	5,5	3,0	R TF3.R.01.00	L TF3.L.01.00

Bestellbeispiel // Order example: **TF3.01.008.10.040 YER X600** (R = Rechte Ausführung // Right hand version, X600 = Schneidstoff // Grade)

Längs- und Konturdrehen, mit Spantreppe Typ E

Typ „E“ Spantreppe, für optimale Leistung und Spanbildung.

Turning and Profiling, Cutting Edge Design „E“

Cutting edge design „E“, for high performance and chip control.

Schnittwerte (Start) // Cutting parameters (start)

f	Vc
0,08 mm/U	Seite/Page 429

Passende Klemmhalter auf Seite // Suitable toolholders on page
394, 396, 397, 400

SP

HM

R

Legende
Legend

410

Scan
QR-Code

Oder besuchen Sie // Or Visit
www.simtek.info/cp/1028

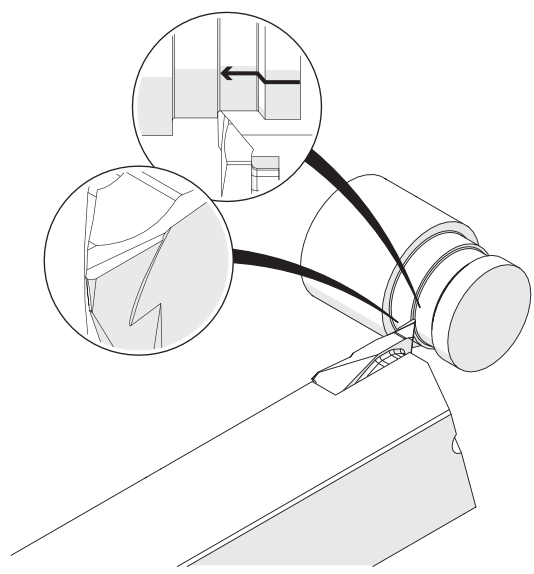
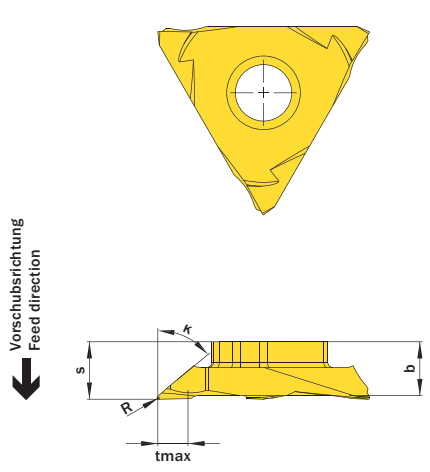


Abbildung zeigt / Drawing shows: TF3.01.050.10.020 YER

K	R mm	Artikelnummer Part number	Webcode www.simtek.com/webcode	Unsere erste Wahl Our first choice				b mm	S mm	tmax mm	Connectcode www.simtek.com/ccode
				P	K	M	N				
▼ κ=30°											
30°	0,2	TF3.01.030.10.020 YER/L	R AWZV L AWZU	X802	X602	5,2	5,5	3,0	R TF3.R.01.00 L TF3.L.01.00		
30°	0,4	TF3.01.030.10.040 YER/L	R AWZX L AWZW	X802	X602	5,2	5,5	3,0	R TF3.R.01.00 L TF3.L.01.00		
▼ κ=50°											
50°	0,2	TF3.01.050.10.020 YER/L	R AWZ3 L AWZ2	X802	X602	5,3	5,6	3,0	R TF3.R.01.00 L TF3.L.01.00		
50°	0,4	TF3.01.050.10.040 YER/L	R AWZ5 L AWZ4	X802	X602	5,3	5,6	3,0	R TF3.R.01.00 L TF3.L.01.00		

Bestellbeispiel // Order example: TF3.01.050.10.020 YER X802 (R = Rechte Ausführung // Right hand version, X802 = Schneidstoff // Grade)

simturn AX
simturn DX
simturn PX
simturn H2
simturn K2
simturn C4
simturn GX
simturn E3
simturn E12
simturn FX
simturn Decolletage
simturn OA
Index

Rückwärtsdrehen

Wendeschneidplatte für das Rückwärtsdrehen bzw. Längsdrehen „hinter Bund“.

Back Turning

Indexable insert for back turning as well as for turning „behind shoulder“.

Schnittwerte (Start) // Cutting parameters (start)

f	Vc
0,08 mm/U	Seite/Page 429

Passende Klemmhalter auf Seite // Suitable toolholders on page
394, 396, 397, 400



Legende
 Legend 410



Scan QR-Code
 Oder besuchen Sie // Or Visit
www.simtek.info/cp/1075

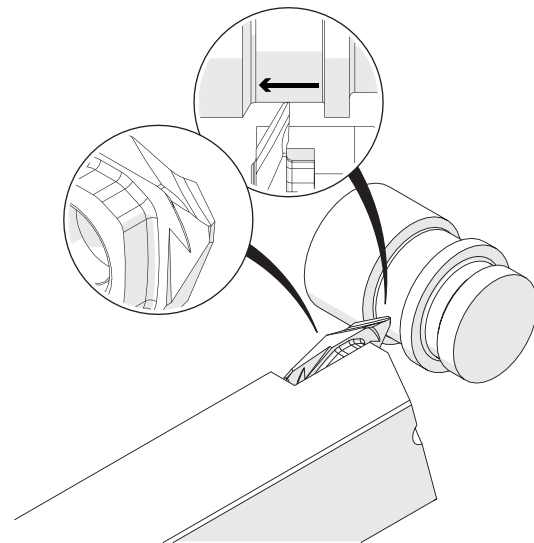
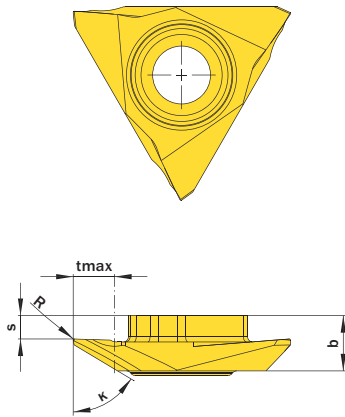


Abbildung zeigt / Drawing shows: TF3.059.02.06.020 YY R

K	R	Artikelnummer Part number	Webcode www.simtek.com/webcode	Unsere erste Wahl Our first choice				b	S	tmax	Connectcode www.simtek.com/ccode
				P	K	M	S				
59°	0,2	TF3.01.059.26.020 YYR/L	R AXTH L AXTJ	X800	X600		5,35	2,26	4,0	R TF3.R.01.00 L TF3.L.01.00	
59°	0,4	TF3.01.059.26.040 YYR/L	R AXTK L AXTM	X800	X600		5,35	2,26	4,0	R TF3.R.01.00 L TF3.L.01.00	

Bestellbeispiel // Order example: **TF3.01.059.26.020 YYR X800** (R = Rechte Ausführung // Right hand version, X800 = Schneidstoff // Grade)

Einstechdrehen, mit Spantreppe Typ „E“

Typ „E“ Spantreppe, für optimale Leistung und Spanbildung.

Grooving, Cutting Edge Design Type „E“

Cutting edge design type „E“, for high performance and chip control.

Schnittwerte (Start) // Cutting parameters (start)

f	Vc
0,08 mm/U	Seite/Page 429

Passende Klemmhalter auf Seite // Suitable toolholders on page
 394, 396, 397, 400

SP

HM

R

Legende
 Legend

410

Scan
QR-Code

Oder besuchen Sie // Or Visit
www.simtek.info/cp/1029

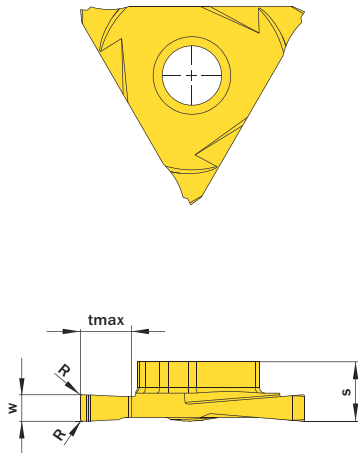
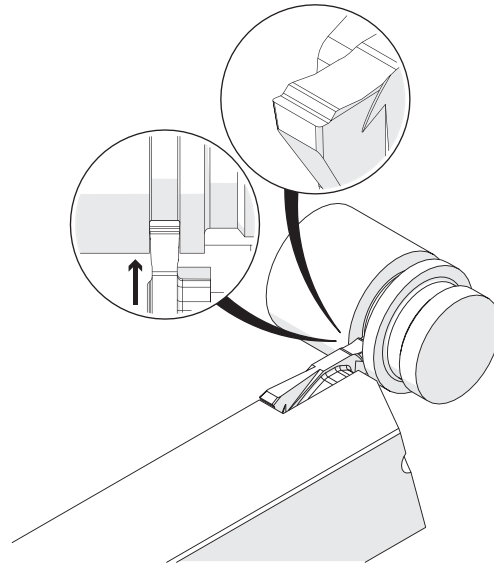


Abbildung zeigt / Drawing shows: TF3.01.0250.020 NER



w ±0.02 mm	R mm	Artikelnummer Part number	Webcode www.simtek.com/webcode		Unsere erste Wahl Our first choice		S mm	tmax mm	Connectcode www.simtek.com/ccode	
			P	K	M	N			S	R
1,5	0,2	TF3.01.0150.020 NER/L	R AWZN	L AWZM	X802	X602	5,5	5,0	R TF3.R.01.00	L TF3.L.01.00
1,8	0,2	TF3.01.0180.020 NER/L	R AX72	L AYW4	X802	X602	5,5	5,0	R TF3.R.01.00	L TF3.L.01.00
2,0	0,2	TF3.01.0200.020 NER/L	R AWZQ	L AWZP	X802	X602	5,5	5,0	R TF3.R.01.00	L TF3.L.01.00
2,5	0,2	TF3.01.0250.020 NER/L	R AWZT	L AWZS	X802	X602	5,5	5,0	R TF3.R.01.00	L TF3.L.01.00
3,0	0,2	TF3.01.0300.020 NER/L	R AWZZ	L AWZY	X802	X602	5,5	5,0	R TF3.R.01.00	L TF3.L.01.00
4,0	0,2	TF3.01.0400.020 NER/L	R AWZ1	L AWZ0	X802	X602	5,5	5,0	R TF3.R.01.00	L TF3.L.01.00
5,0	0,2	TF3.01.0500.020 NER/L	R AWZ7	L AWZ6	X802	X602	5,5	5,0	R TF3.R.01.00	L TF3.L.01.00

Bestellbeispiel // Order example: **TF3.01.0400.020 NER X802** (R = Rechte Ausführung // Right hand version, X802 = Schneidstoff // Grade)

simturn AX
simturn DX
simturn PX
simturn H2
simturn K2
simturn C4
simturn GX
simturn E3
simturn E12
simturn FX
simturn Decolletage
simturn OA
Index

Einstecken und Profildrehen

CNC-Konturdrehen.

Grooving and Profiling

CNC Profiling.

Schnittwerte (Start) // Cutting parameters (start)

f	Vc
0,08 mm/U	Seite/Page 429

Passende Klemmhalter auf Seite // Suitable toolholders on page
394, 396, 397, 400

SP

HM

R

Legende
Legend

410

Scan
QR-Code

Oder besuchen Sie // Or Visit
www.simtek.info/cp/1262

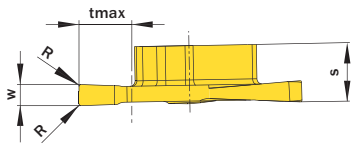
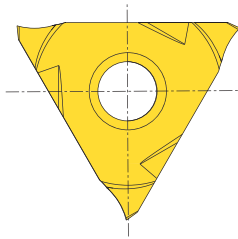
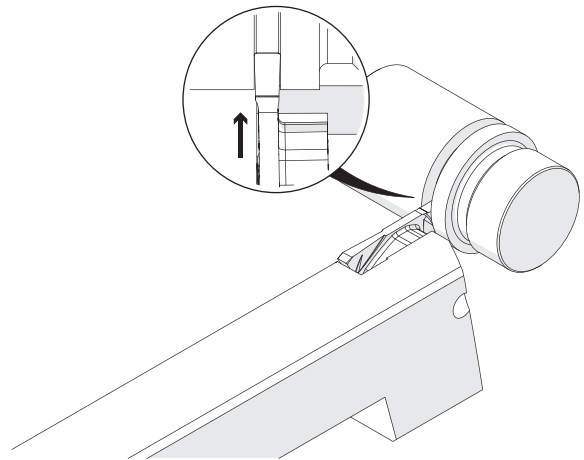


Abbildung zeigt / Drawing shows: TF3.01.0200.020 NS R



$w \pm 0.02$	R	Artikelnummer Part number	Webcode www.simtek.com/webcode	Unsere erste Wahl Our first choice	S	tmax	Connectcode www.simtek.com/ccode
mm	mm			P K M N S	mm	mm	
1,0	0,2	TF3.01.0100.020 NSR/L	R A10V L A197	X808 X408	5,35	5,0	R TF3.R.01.00 L TF3.L.01.00
1,5	0,2	TF3.01.0150.020 NSR/L	R A06Q L A06S	X800 X600	5,5	5,0	R TF3.R.01.00 L TF3.L.01.00
2,0	0,2	TF3.01.0200.020 NSR/L	R A06N L A06P	X800 X600	5,5	5,0	R TF3.R.01.00 L TF3.L.01.00
2,5	0,2	TF3.01.0250.020 NSR/L	R A06K L A06M	X800 X600	5,5	5,0	R TF3.R.01.00 L TF3.L.01.00

Bestellbeispiel // Order example: **TF3.01.0100.020 NSR X808** (R = Rechte Ausführung // Right hand version, X808 = Schneidstoff // Grade)

Einstecken und Profildrehen in Leichtmetallen

CNC-Konturdrehen mit spezieller Geometrie für die Bearbeitung von Leichtmetallen.



Grooving and Profiling in light alloys

CNC profiling with special geometry for applications in light alloys.

Schnittwerte (Start) // Cutting parameters (start)

f	Vc
0,08 mm/U	Seite/Page 429

Passende Klemhalter auf Seite // Suitable toolholders on page
394, 396, 397, 400

 Legende Legend 410
 Scan QR-Code Oder besuchen Sie // Or Visit www.simtek.info/cp/1263

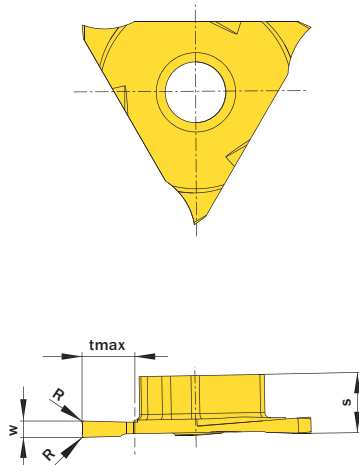
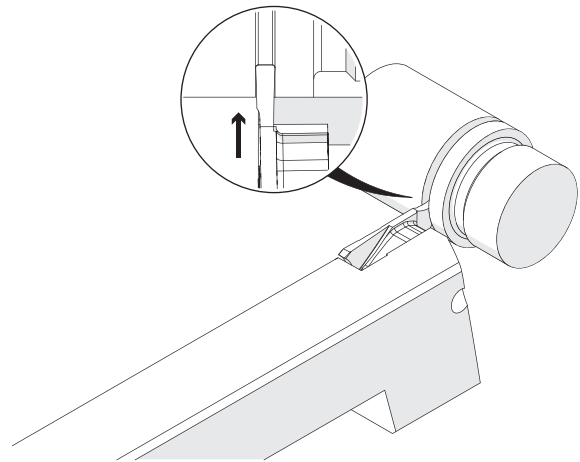


Abbildung zeigt / Drawing shows: TF3.01.0150.020 NC R



w ±0,02	R	Artikelnummer Part number	Webcode www.simtek.com/webcode	Unsere erste Wahl Our first choice	S	tmax	Connectcode www.simtek.com/code
mm	mm			P K M N S	mm	mm	
1,5	0,2	TF3.01.0150.020 NCR	A101	X808 X408	5,5	5,0	TF3.R.01.00
2,0	0,2	TF3.01.0200.020 NCR	A102	X808 X408	5,5	5,0	TF3.R.01.00

Bestellbeispiel // Order example: **TF3.01.0200.020 NCR X808** (R = Rechte Ausführung // Right hand version, X808 = Schneidstoff // Grade)

Einstechdrehen, mit Spanformgeometrie Typ „D“

Einstechdrehen mit geschliffener Spanformgeometrie
Typ „D“ für kontrollierte Spanbildung.

Grooving, Cutting Edge Design Type „D“

Grooving with ground geometry type „D“ for improved chip control.

Schnittwerte (Start) // Cutting parameters (start)

f	Vc
0,08 mm/U	Seite/Page 429

Passende Klemmhalter auf Seite // Suitable toolholders on page
394, 396, 397, 400

SP	HM	R	Legende Legend	410
-----------	-----------	----------	-------------------	------------

Scan QR-Code Oder besuchen Sie // Or Visit
www.simtek.info/cp/1226

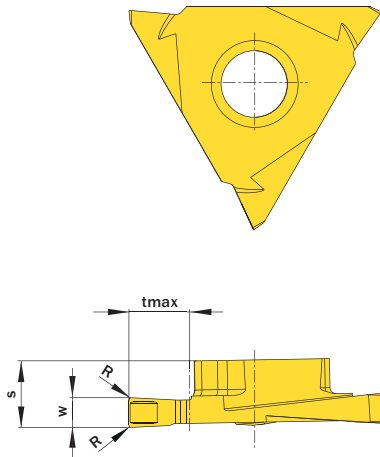
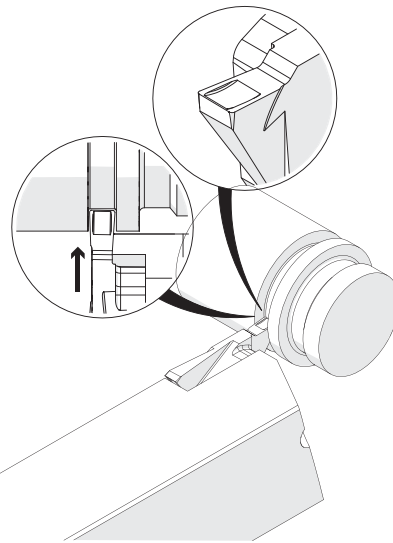


Abbildung zeigt / Drawing shows: TF3.01.0250.020 ND R



w ±0,02	R	Artikelnummer Part number	Webcode www.simtek.com/webcode		Unsere erste Wahl Our first choice		S	tmax	Connectcode www.simtek.com/code	
mm	mm		P	K	M	N	mm	mm		
1,5	0,2	TF3.01.0150.020 NDR/L	R AZXD	L AZXC	X800	X600	5,5	5,0	R TF3.R.01.00	L TF3.L.01.00
1,8	0,2	TF3.01.0180.020 NDR/L	R AZXE	L AZXF	X800	X600	5,5	5,0	R TF3.R.01.00	L TF3.L.01.00
2,0	0,2	TF3.01.0200.020 NDR/L	R AZXH	L AZXG	X800	X600	5,5	5,0	R TF3.R.01.00	L TF3.L.01.00
2,5	0,2	TF3.01.0250.020 NDR/L	R AZXJ	L AZXK	X800	X600	5,5	5,0	R TF3.R.01.00	L TF3.L.01.00
3,0	0,2	TF3.01.0300.020 NDR/L	R AZXN	L AZXM	X800	X600	5,5	5,0	R TF3.R.01.00	L TF3.L.01.00
4,0	0,2	TF3.01.0400.020 NDR/L	R AZXP	L AZXQ	X800	X600	5,5	5,0	R TF3.R.01.00	L TF3.L.01.00
5,0	0,2	TF3.01.0500.020 NDR/L	R AZXT	L AZXS	X800	X600	5,5	5,0	R TF3.R.01.00	L TF3.L.01.00

Bestellbeispiel // Order example: **TF3.01.0150.020 NDR X800** (R = Rechte Ausführung // Right hand version, X800 = Schneidstoff // Grade)

Axiale Gewindefreistiche

Geeignet für axiale Gewindefreistiche. Eingebaut unter 45°.

Face Thread Reliefs

Suitable for thread reliefs. Mounted in a 45° toolholder.

Schnittwerte (Start) // Cutting parameters (start)

f	Vc
0,08 mm/U	Seite/Page 429

Passende Klemmhalter auf Seite // Suitable toolholders on page
 395

SP

HM

L

Legende
Legend

410

Scan
QR-Code

Oder besuchen Sie // Or Visit
www.simtek.info/cp/1127

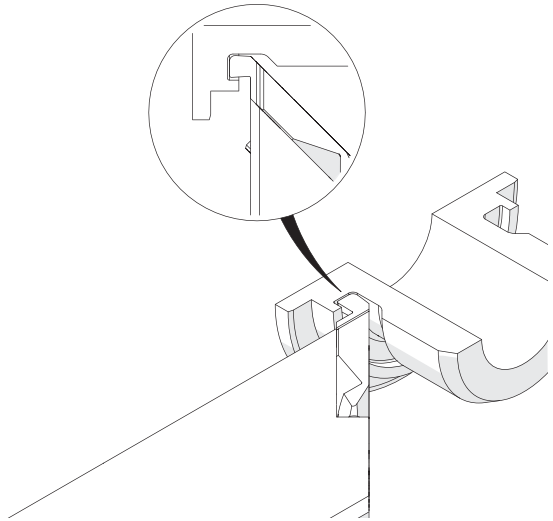
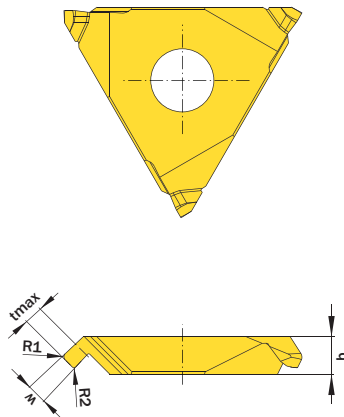


Abbildung zeigt / Drawing shows: TF3.00.0815.45.04 E L


ØDmin (Min. Bohrung) ØDmin (min. bore)	w	R1	Artikelnummer Part number	Webcode www.simtek.com/webcode	Unsere erste Wahl Our first choice				R2	b	tmax	Connectcode www.simtek.com/code
					P	K	M	S				
8,0	1,5	0,2	TF3.00.0815.45.02 E R/L	R A4TF	L A1GA	X800	X600	0,2	3,3	1,6	R TF3.L.45.00.03 L TF3.R.45.00.03 new	
8,0	1,5	0,4	TF3.00.0815.45.04 E R/L	R A4TH	L AYJV	X800	X600	0,2	3,3	1,6	R TF3.L.45.00.03 L TF3.R.45.00.03 new	
12,0	2,0	0,2	TF3.00.1220.45.02 E R/L	R A4TK	L A1EJ	X800	X600	0,2	3,3	2,0	R TF3.L.45.00.03 L TF3.R.45.00.03 new	
12,0	2,0	0,5	TF3.00.1220.45.05 E R/L	R A4TN	L AYJW	X800	X600	0,2	3,3	2,0	R TF3.L.45.00.03 L TF3.R.45.00.03 new	
20,0	2,4	0,6	TF3.00.2024.45.06 E R/L	R A4TQ	L AYJX	X800	X600	0,2	3,3	2,0	R TF3.L.45.00.03 L TF3.R.45.00.03 new	

Bestellbeispiel // Order example: **TF3.00.2024.45.06 E R X800** (R = Rechte Ausführung // Right hand version, X800 = Schneidstoff // Grade)

simturn AX
simturn DX
simturn PX
simturn H2
simturn K2
simturn C4
simturn GX
simturn E3
simturn E12
simturn FX
simturn Decolletage
simturn OA
Index

Info

Legende
Legend

- SP** Schneidwerkzeug aus Hartmetall // Carbide insert // Outils coupants en carbure de tungstène // Inserto in metallo duro
HM Inserto de carburo // Karbür kesici uç
- TW** Trägerwerkzeug aus Stahl // Steel toolholder // Porte-outils en acier // Porta inserto in acciaio
ST Porta-herramientas de acero // Çelik tutucu
- L** Links wie gezeichnet // Left hand version shown // A gauche comme présenté // In figura utensile sinistro
 Versión izquierda, como se muestra // Sol model
- R** Rechts wie gezeichnet // Right hand version shown, left hand version inversely // A droite comme présenté // In figura utensile destro
 Modelo derecho // Sağ model
-  Innere Kühlmittelzufuhr // Through coolant // Refroidissement interne // Lubrificazione interna
 Con refrigeración interna // İçten soğutmalı

Index

simturn FX Produktverzeichnis
simturn FX Product list

Artikelnr. // Part Nr.	S/P	Artikelnr. // Part Nr.	S/P	Artikelnr. // Part Nr.	S/P
TF3.00.062S.D.45.10.00 R	395	TF3.01.0500.020 NDL	408	TOG.K.TF3.01.B1 L	400
TF3.00.075S.D.45.12.00 R	395	TF3.01.0500.020 NDR	408	TOG.K.TF3.01.B1 R	400
TF3.00.0815.45.02 E L	409	TF3.01.0500.020 NEL	405		
TF3.00.0815.45.02 E R	409	TF3.01.0500.020 NER	405		
TF3.00.0815.45.04 E L	409	TF3.01.059.26.020 YYL	404		
TF3.00.0815.45.04 E R	409	TF3.01.059.26.020 YYR	404		
TF3.00.100S.D.45.15.00 R	395	TF3.01.059.26.040 YYL	404		
TF3.00.1220.45.02 E L	409	TF3.01.059.26.040 YYR	404		
TF3.00.1220.45.02 E R	409	TF3.01.075S.A.10.08 CG R	396		
TF3.00.1220.45.05 E L	409	TF3.01.1.000.A.15.00 R	394		
TF3.00.1220.45.05 E R	409	TF3.01.100S.A.10.08 CG R	396		
TF3.00.1616.D.45.10.00 L	395	TF3.01.100S.A.10.10 CG R	396		
TF3.00.1616.D.45.10.00 R	395	TF3.01.100S.D.90.15.00 L	395		
TF3.00.2020.D.45.12.00 L	395	TF3.01.100S.D.90.15.00 R	395		
TF3.00.2020.D.45.12.00 R	395	TF3.01.1212.A.10.00 CG L	396		
TF3.00.2024.45.06 E L	409	TF3.01.1212.A.10.00 CG R	396		
TF3.00.2024.45.06 E R	409	TF3.01.1212.A.10.00 L	394		
TF3.00.2525.D.45.15.00 L	395	TF3.01.1212.A.10.00 R	394		
TF3.00.2525.D.45.15.00 R	395	TF3.01.1616.A.10.00 CG L	396		
TF3.01.0.625.A.12.00 R	394	TF3.01.1616.A.10.00 CG R	396		
TF3.01.008.10.020 YEL	402	TF3.01.1616.A.12.00 L	394		
TF3.01.008.10.020 YER	402	TF3.01.1616.A.12.00 R	394		
TF3.01.008.10.040 YEL	402	TF3.01.1616.A.12.08 L	394		
TF3.01.008.10.040 YER	402	TF3.01.1616.A.12.08 R	394		
TF3.01.0100.020 NSL	406	TF3.01.2020.A.10.00 CG L	396		
TF3.01.0100.020 NSR	406	TF3.01.2020.A.10.00 CG R	396		
TF3.01.0150.020 NCR	407	TF3.01.2020.A.10.08 CG L	396		
TF3.01.0150.020 NDL	408	TF3.01.2020.A.10.08 CG R	396		
TF3.01.0150.020 NDR	408	TF3.01.2020.A.10.10 CG L	396		
TF3.01.0150.020 NEL	405	TF3.01.2020.A.10.10 CG R	396		
TF3.01.0150.020 NER	405	TF3.01.2020.A.12.00 L	394		
TF3.01.0150.020 NSL	406	TF3.01.2020.A.12.00 R	394		
TF3.01.0150.020 NSR	406	TF3.01.2020.A.12.08 L	394		
TF3.01.0180.020 NDL	408	TF3.01.2020.A.12.08 R	394		
TF3.01.0180.020 NDR	408	TF3.01.2020.A.12.10 L	394		
TF3.01.0180.020 NEL	405	TF3.01.2020.A.12.10 R	394		
TF3.01.0180.020 NER	405	TF3.01.2020.D.90.12.00 L	395		
TF3.01.0200.020 NCR	407	TF3.01.2020.D.90.12.00 R	395		
TF3.01.0200.020 NDL	408	TF3.01.2525.A.10.00 CG L	396		
TF3.01.0200.020 NDR	408	TF3.01.2525.A.10.00 CG R	396		
TF3.01.0200.020 NEL	405	TF3.01.2525.A.10.08 CG L	396		
TF3.01.0200.020 NER	405	TF3.01.2525.A.10.08 CG R	396		
TF3.01.0200.020 NSL	406	TF3.01.2525.A.15.00 L	394		
TF3.01.0200.020 NSR	406	TF3.01.2525.A.15.00 R	394		
TF3.01.0250.020 NDL	408	TF3.01.2525.A.15.08 L	394		
TF3.01.0250.020 NDR	408	TF3.01.2525.A.15.08 R	394		
TF3.01.0250.020 NEL	405	TF3.01.2525.D.90.15.00 L	395		
TF3.01.0250.020 NER	405	TF3.01.2525.D.90.15.00 R	395		
TF3.01.0250.020 NSL	406	TOA.TF3.00.A.19.05 L	397		
TF3.01.0250.020 NSR	406	TOA.TF3.00.A.19.05 R	397		
TF3.01.030.10.020 YEL	403	TOA.TF3.00.B.39.06 L	399		
TF3.01.030.10.020 YER	403	TOA.TF3.00.B.39.06 R	399		
TF3.01.030.10.040 YEL	403	TOA.TF3.00.B.39.08 L	399		
TF3.01.030.10.040 YER	403	TOA.TF3.00.B.39.08 R	399		
TF3.01.0300.020 NDL	408	TOA.TF3.00.B.39.10 L	399		
TF3.01.0300.020 NDR	408	TOA.TF3.00.B.39.10 R	399		
TF3.01.0300.020 NEL	405	TOA.TF3.01.A.19.05 L	397		
TF3.01.0300.020 NER	405	TOA.TF3.01.A.19.05 R	397		
TF3.01.0400.020 NDL	408	TOA.TF3.01.A.29.05 L	397		
TF3.01.0400.020 NDR	408	TOA.TF3.01.A.29.05 R	397		
TF3.01.0400.020 NEL	405	TOA.TF3.50.A.19.05 L	397		
TF3.01.0400.020 NER	405	TOA.TF3.50.A.19.05 R	397		
TF3.01.050.10.020 YEL	403	TOA.TF3.51.C.29.05 L	398		
TF3.01.050.10.020 YER	403	TOA.TF3.51.C.29.05 R	398		
TF3.01.050.10.040 YEL	403	TOG.K.TF3.01.A1 L	400		
TF3.01.050.10.040 YER	403	TOG.K.TF3.01.A1 R	400		

Das Werkzeugsystem im Überblick
The Tool System Overview

Formwerkzeuge bieten **immense Einsparpotenziale.**

Form tools provide **immense potential** savings.

Formwerkzeuge bis 66,0 mm Breite.
Form tools up to 66,0 mm wide.

Nutzen Sie diese Einsparpotenziale durch den Einsatz spezieller Profil- und Formwerkzeuge.

Generate these savings by using special form and profiling tools.

Gerne bieten wir Ihnen auf Anfrage, mit diesem System das fertige Hochleistungs-Formwerkzeug aus dem Hause SIMTEK vollständig geschliffen an. Alternativ stehen auch Halbzeuge zur Verfügung, die Sie eigenständig nach Ihren Anforderungen nacharbeiten können.

You can choose between the fully ground form insert made by SIMTEK and the semi-finished inserts from the following pages. These semi-finished inserts can be used to produce individual form tools on your own.

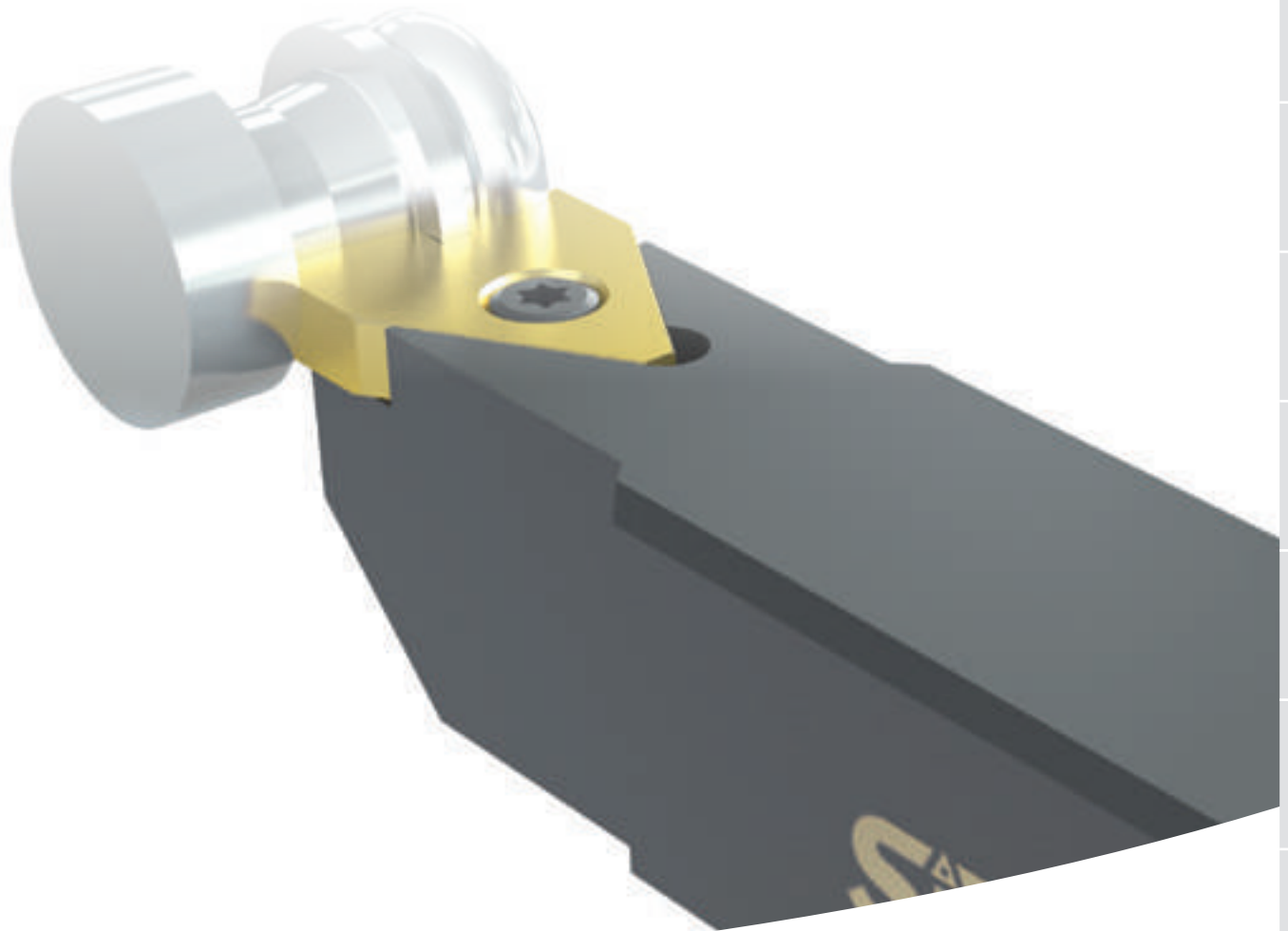
SIMTEK-Decolletage-Schneidwerkzeuge sind in verschiedenen Breiten bis zu 66,0 mm verfügbar!

SIMTEK Decolletage cutting tools are available in widths up to 66,0 mm.

» Sonderprofile erhalten Sie auf Anfrage. // Special cutting inserts are available upon request.

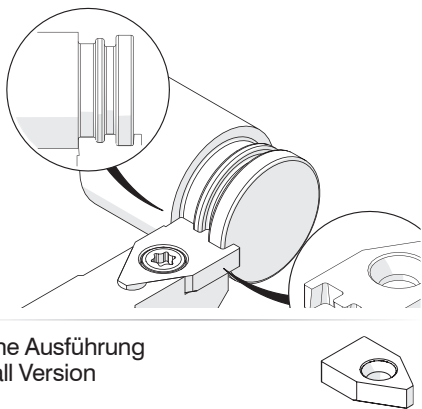
Bitte beachten Sie die allgemeinen Gebrauchshinweise auf Seite
Please read the general instructions for use on page

433



Seite
Page

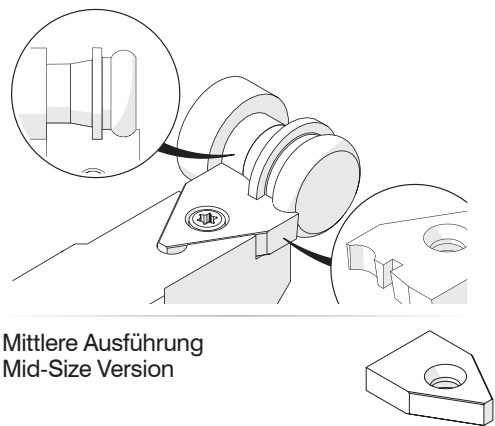
420



Kleine Ausführung
Small Version

Seite
Page

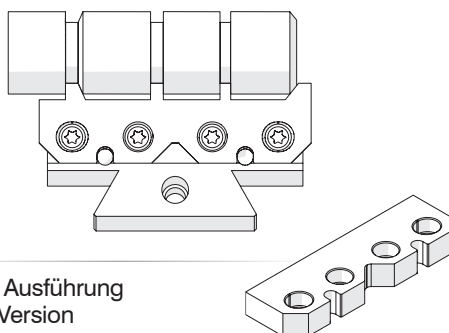
421



Mittlere Ausführung
Mid-Size Version

Seite
Page

422



Breite Ausführung
Wide Version

simturn AX

simturn DX

simturn PX

simturn H2

simturn K2

simturn C4

simturn GX

simturn E3

simturn E12

simturn FX

simturn
Decolletage

simturn OA

Index

413

Klemmhalter, Formstechen

Quadratschaft-Trägerwerkzeug für den Einbau von F10-Decolletageplatten unter 0°.

Toolholder, Profiling

Square shank 0°-toolholder for mounting F10-Decolletage-inserts.

Anzugsmoment (Schraube) // Tightening torque (screw)

"F M4x11 T15F": 4,5 Nm
 "F M4x8,5 T15F": 4,5 Nm



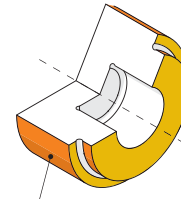
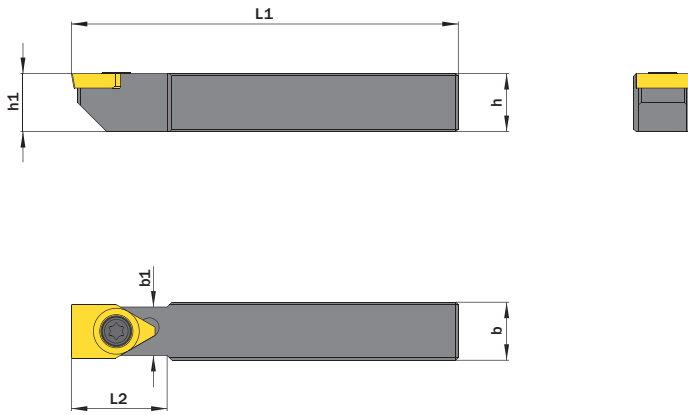
TW Legende
ST Legend

423



Scan QR-Code

Oder besuchen Sie // Or Visit www.simtek.info/cp/729



- Hauptsächlich geeignet für diese Flächen
 Mainly designed for these surfaces
- Je nach Schneidplatte/Aufnahme ebenfalls möglich
 Also possible depending on insert/fixation type

Abbildung zeigt / Drawing shows: F10.1212.A11.08.03

h	b	L1	Artikelnummer Part number	Webcode www.simtek.com/webcode	b1	h1	L2	Schraube Screw	Schraubenschlüssel Screw driver	Connectcode www.simtek.com/code
mm	mm	mm			mm	mm	mm			
▼ Connectcode = TF10.A.30										
10,0	10,0	80,0	F10.1010.A11.08.03	ATSK	10,0	10,0	-	FM4x8,5T15F	T15F	TF10.A.30
12,0	12,0	80,0	F10.1212.A11.08.03	ATSG	10,0	12,0	20,0	FM4x11T15F	T15F	TF10.A.30
▼ Connectcode = TF10.A.45										
10,0	10,0	80,0	F10.1010.A11.08.04	ATSJ	10,0	10,0	-	FM4x8,5T15F	T15F	TF10.A.45
12,0	12,0	80,0	F10.1212.A11.08.04	ATSH	10,0	12,0	20,0	FM4x11T15F	T15F	TF10.A.45

Bestellbeispiel // Order example: **F10.1010.A11.08.03**

Klemmhalter, Formstechen

Quadratschaft-Trägerwerkzeug für den Einbau von F10-Decolletageplatten unter 6°.

Toolholder, Profiling

Square shank 6°-toolholder for mounting F10-Decolletage-inserts.

Anzugsmoment (Schraube) // Tightening torque (screw)

4,5 Nm



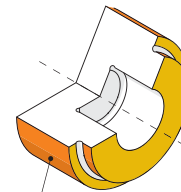
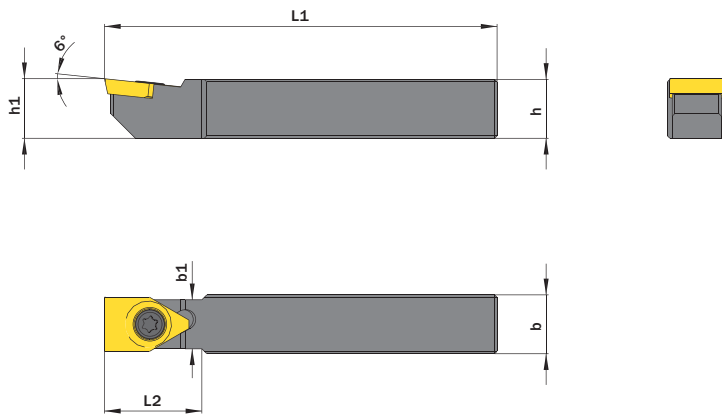
TW Legende
ST Legend

423



Scan QR-Code

Oder besuchen Sie // Or Visit www.simtek.info/cp/730



- Hauptsächlich geeignet für diese Flächen
 Mainly designed for these surfaces
- Je nach Schneidplatte/Aufnahme ebenfalls möglich
 Also possible depending on insert/fixation type

Abbildung zeigt / Drawing shows: F10.1212.B11.08.03

h	b	L1	Artikelnummer Part number	Webcode www.simtek.com/webcode	b1	h1	L2	Schraube Screw	Schraubenschlüssel Screw driver	Connectcode www.simtek.com/ccode
mm	mm	mm			mm	mm	mm			
▼ Connectcode = TF10.B.30										
10,0	10,0	80,0	F10.1010.B11.08.03	ATSM	10,0	10,0	-	FM4x8,5T15F	T15F	TF10.B.30
12,0	12,0	80,0	F10.1212.B11.08.03	ATSP	10,0	12,0	20,0	FM4x8,5T15F	T15F	TF10.B.30 <small>upd</small>
▼ Connectcode = TF10.B.45										
10,0	10,0	80,0	F10.1010.B11.08.04	ATSN	10,0	10,0	-	FM4x8,5T15F	T15F	TF10.B.45
12,0	12,0	80,0	F10.1212.B11.08.04	ATSQ	10,0	12,0	20,0	FM4x8,5T15F	T15F	TF10.B.45 <small>upd</small>

Bestellbeispiel // Order example: **F10.1010.B11.08.04**

simturn AX
 simturn DX
 simturn PX
 simturn H2
 simturn K2
 simturn C4
 simturn GX
 simturn E3
 simturn E12
 simturn FX
 simturn Decolletage
 simturn OA
 Index

Klemmhalter, Formstechen

Quadratschaft-Trägerwerkzeug für den Einbau von F12-Decolletageplatten unter 0°.

Toolholder, Profiling

Square shank 0°-toolholder for mounting F12-Decolletage-inserts.

Anzugsmoment (Schraube) // Tightening torque (screw)

"F M5x11,5 T20R": 6,0 Nm
 "F M5x13 T20R": 6,0 Nm



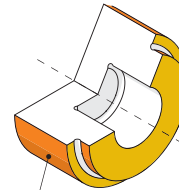
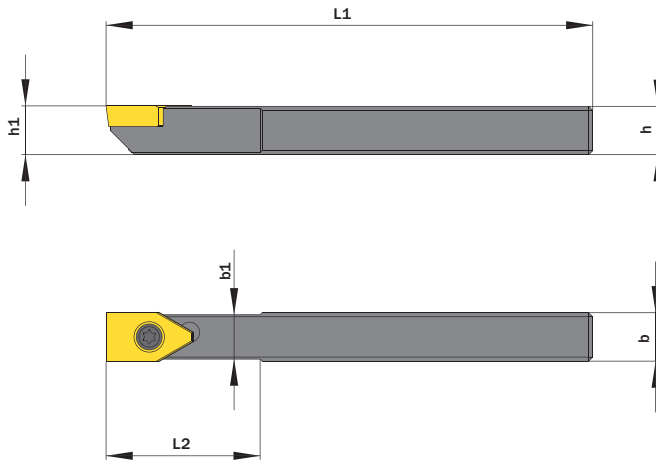
TW Legende
ST Legend

423



Scan QR-Code

Oder besuchen Sie // Or Visit
www.simtek.info/cp/1162



■ Hauptsächlich geeignet für diese Flächen
 Mainly designed for these surfaces

■ Je nach Schneidplatte/Aufnahme ebenfalls möglich
 Also possible depending on insert/fixation type

Abbildung zeigt / Drawing shows: F12.1212.A12.10

h	b	Artikelnummer Part number	Webcode www.simtek.com/webcode	L1	b1	h1 ^{js14}	L2	Schraube Screw	Schraubenschlüssel Screw driver	Connectcode www.simtek.com/code
mm	mm			mm	mm	mm	mm			
▼ Connectcode = TF12.A.12.10										
12,0	12,0	F12.1212.A12.10	AYV9	120,5	11,0	12,0	35,0	F M5x11,5 T20R	T20R	TF12.A.12.10
16,0	16,0	F12.1616.A12.10	AYWD	120,5	11,0	16,0	35,0	F M5x13 T20R	T20R	TF12.A.12.10
20,0	20,0	F12.2020.A12.10	AYWJ	145,5	11,0	20,0	35,0	F M5x13 T20R	T20R	TF12.A.12.10
▼ Connectcode = TF12.A.12.15										
19,05	19,05	F12.0.750.S.A12.15	A4B3	150,0	11,0	19,0	35,0	F M5x13 T20R	T20R	TF12.A.12.15 new inch
12,0	12,0	F12.1212.A12.15	AYWA	125,0	11,0	12,0	35,0	F M5x11,5 T20R	T20R	TF12.A.12.15
16,0	16,0	F12.1616.A12.15	AYWE	125,0	11,0	16,0	35,0	F M5x13 T20R	T20R	TF12.A.12.15
20,0	20,0	F12.2020.A12.15	AYWK	150,0	11,0	20,0	35,0	F M5x13 T20R	T20R	TF12.A.12.15
25,0	25,0	F12.2525.A12.15	AYWQ	150,0	11,0	25,0	35,0	F M5x13 T20R	T20R	TF12.A.12.15
▼ Connectcode = TF12.A.16.12										
12,0	12,0	F12.1212.A16.12	AYWB	122,0	15,0	12,0	35,0	F M5x11,5 T20R	T20R	TF12.A.16.12
16,0	16,0	F12.1616.A16.12	AYWF	122,0	15,0	16,0	35,0	F M5x13 T20R	T20R	TF12.A.16.12
20,0	20,0	F12.2020.A16.12	AYWM	147,0	15,0	20,0	35,0	F M5x13 T20R	T20R	TF12.A.16.12
▼ Connectcode = TF12.A.16.15										
12,0	12,0	F12.1212.A16.15	AYWC	125,0	15,0	12,0	35,0	F M5x11,5 T20R	T20R	TF12.A.16.15
16,0	16,0	F12.1616.A16.15	AYWG	125,0	15,0	16,0	35,0	F M5x13 T20R	T20R	TF12.A.16.15
20,0	20,0	F12.2020.A16.15	AYWN	150,0	15,0	20,0	35,0	F M5x13 T20R	T20R	TF12.A.16.15
25,0	25,0	F12.2525.A16.15	AYWS	150,0	15,0	25,0	35,0	F M5x13 T20R	T20R	TF12.A.16.15
▼ Connectcode = TF12.A.20.15										
16,0	16,0	F12.1616.A20.15	AYWH	125,0	19,0	16,0	35,0	F M5x13 T20R	T20R	TF12.A.20.15
20,0	20,0	F12.2020.A20.15	AYWP	150,0	19,0	20,0	35,0	F M5x13 T20R	T20R	TF12.A.20.15
25,0	25,0	F12.2525.A20.15	AYWT	150,0	19,0	25,0	35,0	F M5x13 T20R	T20R	TF12.A.20.15
▼ Connectcode = TF12.A.25.15										
25,0	25,0	F12.2525.A25.15	AYWU	150,0	24,0	25,0	35,0	F M5x13 T20R	T20R	TF12.A.25.15

Bestellbeispiel // Order example: **F12.1212.A12.10**

Klemmhalter, Formstechen

Quadratschaft-Trägerwerkzeug für den Einbau von F12-Decolletageplatten unter 6°.

Toolholder, Profiling

Square shank 6°-toolholder for mounting F12-Decolletage-inserts.

Anzugsmoment (Schraube) // Tightening torque (screw)

"F M5x11,5 T20R": 6,0 Nm
 "F M5x13 T20R": 6,0 Nm



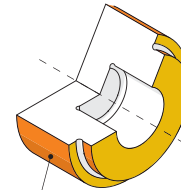
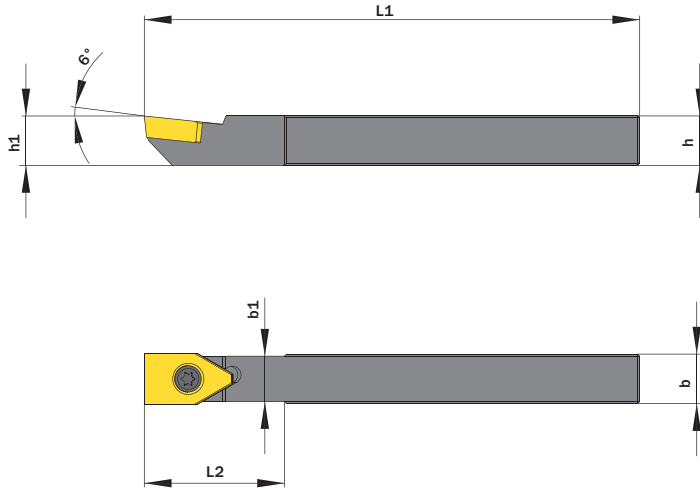
TW Legende
ST Legend

423



Scan QR-Code

Oder besuchen Sie // Or Visit www.simtek.info/cp/1163



- Hauptsächlich geeignet für diese Flächen
 Mainly designed for these surfaces
- Je nach Schneidplatte/Aufnahme ebenfalls möglich
 Also possible depending on insert/fixation type

Abbildung zeigt / Drawing shows: F12.1212.B12.10

h	b	Artikelnummer Part number	Webcode www.simtek.com/webcode	L1	b1	h1 ^{js14}	L2	Schraube Screw	Schraubenschlüssel Screw driver	Connectcode www.simtek.com/code
mm	mm			mm	mm	mm	mm			
▼ Connectcode = TF12.B.12.10										
12,0	12,0	F12.1212.B12.10	AYWV	120,5	11,0	12,0	35,0	F M5x11,5 T20R	T20R	TF12.B.12.10
16,0	16,0	F12.1616.B12.10	AYWZ	120,5	11,0	16,0	35,0	F M5x13 T20R	T20R	TF12.B.12.10
20,0	20,0	F12.2020.B12.10	AYW4	145,5	11,0	20,0	35,0	F M5x13 T20R	T20R	TF12.B.12.10
25,0	25,0	F12.2525.B12.10	AYW9	145,5	11,0	25,0	35,0	F M5x13 T20R	T20R	TF12.B.12.10
▼ Connectcode = TF12.B.12.15										
12,0	12,0	F12.1212.B12.15	AYWW	125,0	11,0	12,0	35,0	F M5x11,5 T20R	T20R	TF12.B.12.15
16,0	16,0	F12.1616.B12.15	AYW0	125,0	11,0	16,0	35,0	F M5x13 T20R	T20R	TF12.B.12.15
20,0	20,0	F12.2020.B12.15	AYW5	150,0	11,0	20,0	35,0	F M5x13 T20R	T20R	TF12.B.12.15
25,0	25,0	F12.2525.B12.15	AYXA	150,0	11,0	25,0	35,0	F M5x13 T20R	T20R	TF12.B.12.15
▼ Connectcode = TF12.B.16.12										
12,0	12,0	F12.1212.B16.12	AYWX	122,0	15,0	12,0	35,0	F M5x11,5 T20R	T20R	TF12.B.16.12
16,0	16,0	F12.1616.B16.12	AYW1	122,0	15,0	16,0	35,0	F M5x13 T20R	T20R	TF12.B.16.12
20,0	20,0	F12.2020.B16.12	AYW6	147,0	15,0	20,0	35,0	F M5x13 T20R	T20R	TF12.B.16.12
▼ Connectcode = TF12.B.16.15										
12,0	12,0	F12.1212.B16.15	AYWY	125,0	15,0	12,0	35,0	F M5x11,5 T20R	T20R	TF12.B.16.15
16,0	16,0	F12.1616.B16.15	AYW2	125,0	15,0	16,0	35,0	F M5x13 T20R	T20R	TF12.B.16.15
20,0	20,0	F12.2020.B16.15	AYW7	150,0	15,0	20,0	35,0	F M5x13 T20R	T20R	TF12.B.16.15
25,0	25,0	F12.2525.B16.15	AYXB	150,0	15,0	25,0	35,0	F M5x13 T20R	T20R	TF12.B.16.15
▼ Connectcode = TF12.B.20.15										
16,0	16,0	F12.1616.B20.15	AYW3	125,0	19,0	16,0	35,0	F M5x13 T20R	T20R	TF12.B.20.15
20,0	20,0	F12.2020.B20.15	AYW8	150,0	19,0	20,0	35,0	F M5x13 T20R	T20R	TF12.B.20.15
25,0	25,0	F12.2525.B20.15	AYXC	150,0	19,0	25,0	35,0	F M5x13 T20R	T20R	TF12.B.20.15
▼ Connectcode = TF12.B.25.15										
25,0	25,0	F12.2525.B25.15	AYXD	150,0	24,0	25,0	35,0	F M5x13 T20R	T20R	TF12.B.25.15

Bestellbeispiel // Order example: F12.2525.B25.15

simturn AX
 simturn DX
 simturn PX
 simturn H2
 simturn K2
 simturn C4
 simturn GX
 simturn E3
 simturn E12
 simturn FX
 simturn Decolletage
 simturn OA
 Index

Klemmhalter, Formstechen

Quadratschaft-Trägerwerkzeug für den Einbau von F12-Decolletageplatten.

Toolholder, Profiling

Square shank toolholder for mounting F12-Decolletage-inserts.

Anzugsmoment (Schraube) // Tightening torque (screw)

6,0 Nm



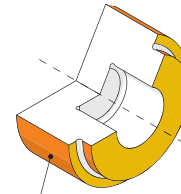
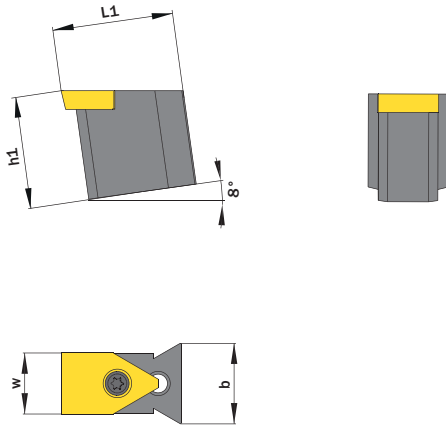
TW Legende
ST Legend

423



Scan QR-Code

Oder besuchen Sie // Or Visit
www.simtek.info/cp/849



- Hauptsächlich geeignet für diese Flächen
 Mainly designed for these surfaces
- Je nach Schneidplatte/Aufnahme ebenfalls möglich
 Also possible depending on insert/fixation type

Abbildung zeigt / Drawing shows: F25AW22.16

b	w	Artikelnummer Part number	Webcode www.simtek.com/webcode	h1	L1	Schraube Screw	Schraubenschlüssel Screw driver	Connectcode www.simtek.com/ccode
mm	mm			mm	mm			
▼ Connectcode = TF12.A.12.15								
22,0	12,0	F25.AW22.12	ATYJ	28,0	23,0	F M5x13 T20R	T20R	TF12.A.12.15
▼ Connectcode = TF12.A.16.15								
22,0	16,0	F25.AW22.16	AHNZ	30,0	32,0	F M5x13 T20R	T20R	TF12.A.16.15
28,0	16,0	F25.AW28.16	AQK3	30,0	32,0	F M5x13 T20R	T20R	TF12.A.16.15
▼ Connectcode = TF12.A.20.15								
22,0	20,0	F25.AW22.20	AQ39	30,0	32,0	F M5x13 T20R	T20R	TF12.A.20.15
28,0	20,0	F25.AW28.20	AFH7	30,0	32,0	F M5x13 T20R	T20R	TF12.A.20.15
▼ Connectcode = TF12.A.25.15								
28,0	25,0	F25.AW28.25	AMPJ	30,0	32,0	F M5x13 T20R	T20R	TF12.A.25.15

Bestellbeispiel // Order example: **F25.AW28.25**

Klemmhalter, Formstechen

Trägerwerkzeug für den Einbau von F12-Decolletageplatten.

Toolholder, Profiling

Toolholder for mounting F12-Decolletage-inserts.

Anzugsmoment (Schraube) // Tightening torque (screw)

7,0 Nm



TW
ST

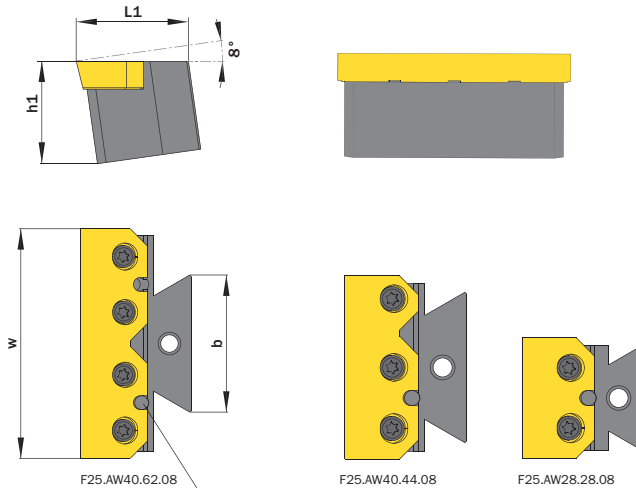
Legende
Legend

423



Scan
QR-Code

Oder besuchen Sie // Or Visit
www.simtek.info/cp/848



Zylinderstift F D4M6x10 DIN6325
 Pin F D4M6x10 DIN6325

- Hauptsächlich geeignet für diese Flächen
 Mainly designed for these surfaces
- Je nach Schneidplatte/Aufnahme ebenfalls möglich
 Also possible depending on insert/fixation type

b	Artikelnummer Part number	Webcode www.simtek.com/webcode	h1	L1	w	Schraube Screw	Schraubenschlüssel Screw driver	Connectcode www.simtek.com/ccode	
mm			mm	mm	mm				
▼ Connectcode = TF12.A.32									
28,0	F25.AW28.28.08	AS90	30,0	32,0	32,0	D M5x12 T20T	T20T	TF12.A.32	upd
▼ Connectcode = TF12.A.48									
40,0	F25.AW40.44.08	AS9Z	30,0	32,0	48,0	D M5x12 T20T	T20T	TF12.A.48	upd
▼ Connectcode = TF12.A.66									
40,0	F25.AW40.62.08	AS9Y	30,0	32,0	66,0	D M5x12 T20T	T20T	TF12.A.66	upd

Bestellbeispiel // Order example: **F25.AW40.44.08**

simturn AX
simturn DX
simturn PX
simturn H2
simturn K2
simturn C4
simturn GX
simturn E3
simturn E12
simturn FX
simturn Decolletage
simturn OA
Index

Halbzeuge, Formstechen

Halbzeuge für komponenten- und kundenspezifische Formeinstiche.

Semi-Finished-Insert, Profiling

Semi-finished-insert for component and client specific forms.

Passende Klemmhalter auf Seite // Suitable toolholders on page
414, 415

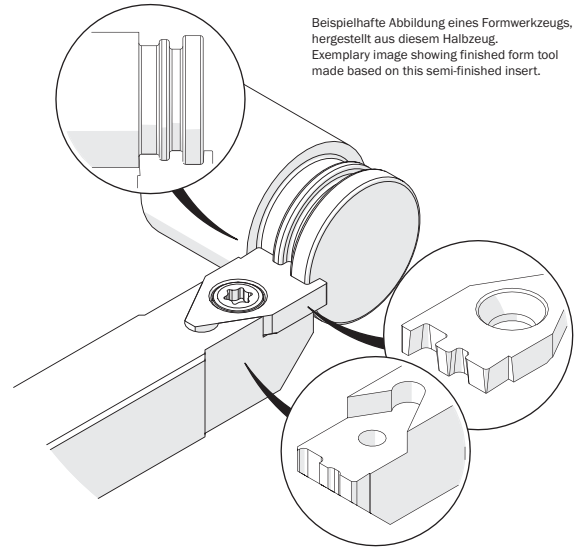
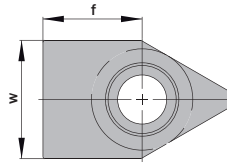
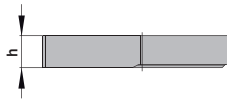


SP Legende
HM Legend

423

Scan
 QR-Code

Oder besuchen Sie // Or Visit
www.simtek.info/cp/727



Beispielhafte Abbildung eines Formwerkzeugs, hergestellt aus diesem Halbzeug.
 Exemplary image showing finished form tool made based on this semi-finished insert.

Abbildung zeigt / Drawing shows: F10.1109.30 M

w mm	h ^{+0,05} mm	Artikelnummer Part number	Webcode www.simtek.com/webcode	Unsere erste Wahl Our first choice	f mm	Connectcode www.simtek.com/code
▼ Connectcode = TF10.A.30 TF10.B.30						
11,1	2,95	F10.1109.30 M	ASAU	X800 X400	9,3	TF10.A.30 TF10.B.30
▼ Connectcode = TF10.A.45 TF10.B.45						
11,1	4,4	F10.1109.45 M	ASAY	X800 X400	9,3	TF10.A.45 TF10.B.45

Bestellbeispiel // Order example: **F10.1109.45 M GF25** (GF25 = Schneidstoff // Grade)

Halbzeuge, Formstechen

Halbzeuge für komponenten- und kundenspezifische Formeinstiche.

Semi-Finished-Insert, Profiling

Semi-finished-insert for component and client specific forms.

Passende Klemmhalter auf Seite // Suitable toolholders on page
416, 417, 418

SP

Legende

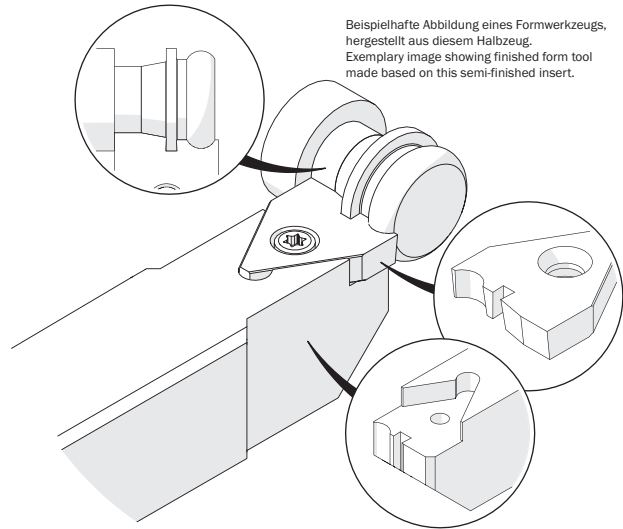
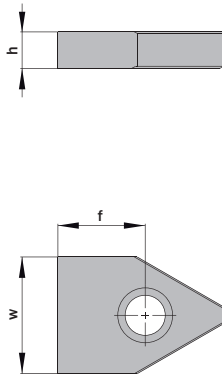
HM

Legend

423

Scan QR-Code

Oder besuchen Sie // Or Visit www.simtek.info/cp/728



Beispielhafte Abbildung eines Formwerkzeugs, hergestellt aus diesem Halbzeug.
 Exemplary image showing finished form tool made based on this semi-finished insert.

Abbildung zeigt / Drawing shows: F12.1612.00 M

w	f	Artikelnummer Part number	Webcode www.simtek.com/webcode	Unsere erste Wahl Our first choice	h ^{+0,05}	Connectcode www.simtek.com/ccode
mm	mm			P K M N S	mm	
▼ w = 12,3 mm						
12,3	10,7	F12.1210.00 M	AMWH	X800 X400	5,0	TF12.A.12.10 TF12.B.12.10
12,3	15,2	F12.1215.00 M	AG2E	X800 X400	5,0	TF12.A.12.15 TF12.B.12.15
▼ w = 16,3 mm						
16,3	12,2	F12.1612.00 M	AKWQ	X800 X400	5,0	TF12.A.16.12 TF12.B.16.12
16,3	15,2	F12.1615.00 M	AECD	X800 X400	5,0	TF12.A.16.15 TF12.B.16.15
▼ w = 20,3 mm						
20,3	15,2	F12.2015.00 M	AA30	X800 X400	5,0	TF12.A.20.15 TF12.B.20.15
▼ w = 25,3 mm						
25,3	15,2	F12.2515.00 M	AGXU	X800 X400	5,0	TF12.A.25.15 TF12.B.25.15

Bestellbeispiel // Order example: **F12.1210.00 M X800** (X800 = Schneidstoff // Grade)

simturn AX
simturn DX
simturn PX
simturn H2
simturn K2
simturn C4
simturn GX
simturn E3
simturn E12
simturn FX
simturn OA
Index

Halbzeuge, Formstechen, breite Ausführung

Halbzeuge für komponenten- und kundenspezifische Formeinstiche.

Semi-Finished-Insert, Profiling

Semi-finished-insert for component and client specific forms.

Passende Klemmhalter auf Seite // Suitable toolholders on page
419



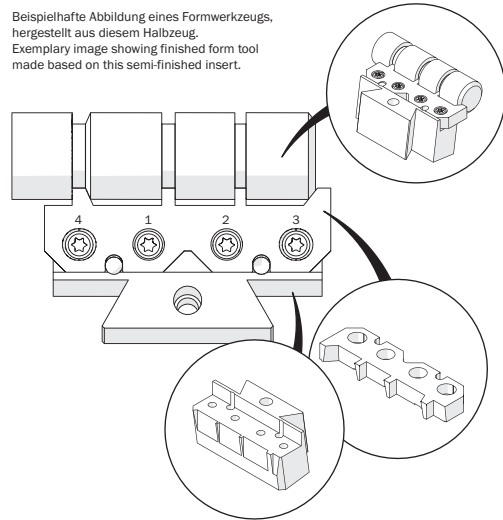
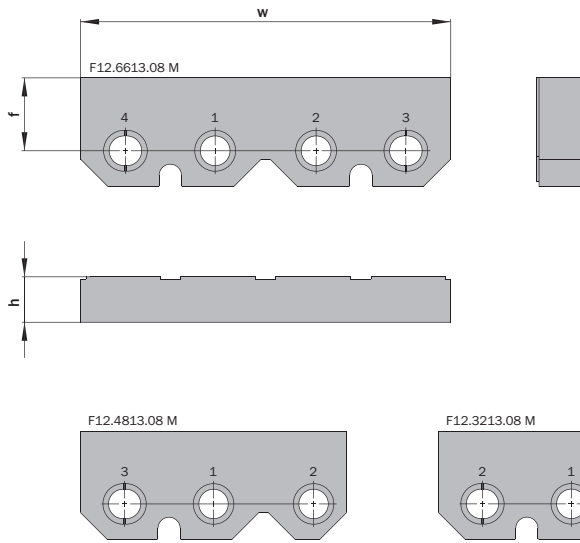
SP Legende
HM Legend

423

Scan QR-Code

Oder besuchen Sie // Or Visit
www.simtek.info/cp/850

Beispielhafte Abbildung eines Formwerkzeugs, hergestellt aus diesem Halbzeug.
 Exemplary image showing finished form tool made based on this semi-finished insert.



Die Reihenfolge des Schraubenanzuges ist auf den Halbzeugen nummeriert!
 Please tighten the screws in the order marked on the semi-finished-insert!

	w mm	Artikelnummer Part number	Webcode www.simtek.com/webcode	Unsere erste Wahl Our first choice P K M N S	h mm	f mm	Connectcode www.simtek.com/ccode
▼ Connectcode = TF12.A.32	32,0	F12.3213.08 M	AVFS	X800 X400	8,1	13,2	TF12.A.32
▼ Connectcode = TF12.A.48	48,0	F12.4813.08 M	ATT4	X800 X400	8,1	13,2	TF12.A.48
▼ Connectcode = TF12.A.66	66,0	F12.6613.08 M	ATT5	X800 X400	8,1	13,2	TF12.A.66

Bestellbeispiel // Order example: **F12.3213.08 M GK10** (GK10 = Schneidstoff // Grade)

Info

Legende
Legend

- SP** Schneidwerkzeug aus Hartmetall // Carbide insert // Outils coupants en carbure de tungstène // Inserto in metallo duro // Inserto de carburo
- HM** // Karbür kesici uç
- TW** Trägerwerkzeug aus Stahl // Steel toolholder // Porte-outils en acier // Porta inserto in acciaio
- ST** Porta-herramientas de acero // Çelik tutucu

simturn AX

simturn DX

simturn PX

simturn H2

simturn K2

simturn C4

simturn GX

simturn E3

simturn E12

simturn FX

simturn
Deco/letage

simturn OA

Index

423

Index

simturn Decolletage Produktverzeichnis
simturn Decolletage Product List

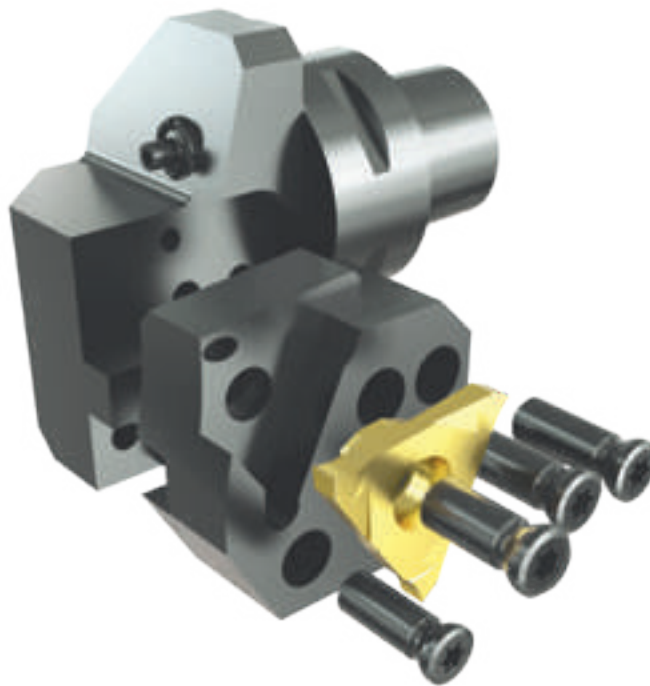
Artikelnr. // Part Nr.	S/P
F10.1010.A11.08.03	414
F10.1010.A11.08.04	414
F10.1010.B11.08.03	415
F10.1010.B11.08.04	415
F10.1109.30 M	420
F10.1109.45 M	420
F10.1212.A11.08.03	414
F10.1212.A11.08.04	414
F10.1212.B11.08.03	415
F10.1212.B11.08.04	415
F12.0750.S.A12.15	416
F12.1210.00 M	421
F12.1212.A12.10	416
F12.1212.A12.15	416
F12.1212.A16.12	416
F12.1212.A16.15	416
F12.1212.B12.10	417
F12.1212.B12.15	417
F12.1212.B16.12	417
F12.1212.B16.15	417
F12.1215.00 M	421
F12.1612.00 M	421
F12.1615.00 M	421
F12.1616.A12.10	416
F12.1616.A12.15	416
F12.1616.A16.12	416
F12.1616.A16.15	416
F12.1616.A20.15	416
F12.1616.B12.10	417
F12.1616.B12.15	417
F12.1616.B16.12	417
F12.1616.B16.15	417
F12.1616.B20.15	417
F12.2015.00 M	421
F12.2020.A12.10	416
F12.2020.A12.15	416
F12.2020.A16.12	416
F12.2020.A16.15	416
F12.2020.A20.15	416
F12.2020.B12.10	417
F12.2020.B12.15	417
F12.2020.B16.12	417
F12.2020.B16.15	417
F12.2020.B20.15	417
F12.2515.00 M	421
F12.2525.A12.15	416
F12.2525.A16.15	416
F12.2525.A20.15	416
F12.2525.A25.15	416
F12.2525.B12.10	417
F12.2525.B12.15	417
F12.2525.B16.15	417
F12.2525.B20.15	417
F12.2525.B25.15	417
F12.3213.08 M	422
F12.4813.08 M	422
F12.6613.08 M	422
F25.AW22.12	418
F25.AW22.16	418
F25.AW22.20	418
F25.AW28.16	418
F25.AW28.20	418
F25.AW28.25	418
F25.AW28.28.08	419
F25.AW40.44.08	419
F25.AW40.62.08	419

Das Werkzeugsystem im Überblick The Tool System Overview

Bitte beachten Sie die allgemeinen Gebrauchshinweise auf Seite
Please read the general instructions for use on page

433

Modulares System aus Grundträger und Kassette.
Modular system of basic toolholder and cassette.



System bestehend aus modularen Grundhaltern und passenden Kassetten für verschiedene simturn Produktgruppen.

Die Grundträger mit Polygonschäften nach ISO 26623 sind verfügbar für die Innen- und Außenbearbeitung

System of modular basic toolholders and matching cassettes for a variety of simturn product groups.

The basic toolholders with polygonal shanks according to ISO 26623 are available for internal and external applications.

Modularer Grundhalter mit Polygonschaft nach ISO 26623, Radiale Bearbeitung

SIMTEK Trägerwerkzeug mit Polygonschaft aus Stahl nach ISO 26623 für TOA-Kassetten.

Modular Base Toolholder with Polygon Shank According to ISO 26623, Radial Application

SIMTEK toolholder with polygon shank according to ISO 26623 for TOA-cassettes.

Anzugsmoment (Schraube) // Tightening torque (screw)

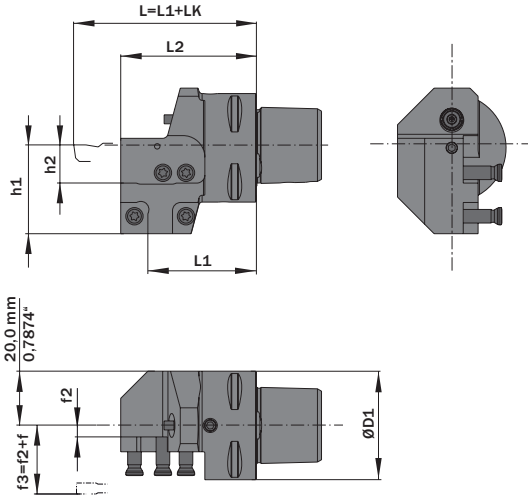
7,0 Nm



Legende
Legend **428**

Scan QR-Code

Oder besuchen Sie // Or Visit www.simtek.info/cp/334



Maße f und LK in Abhängigkeit der Kassette
Measures f and LK depend on cassette

Abbildung zeigt / Drawing shows: TOA.00C4 R

Passende Kassetten // Available cassettes

simturn GX
Seite/Page 297, Seite/Page 299, Seite/Page 301

simturn E3
Seite/Page 327

simturn E12
Seite/Page 367

simturn FX
Seite/Page 397, Seite/Page 398, Seite/Page 399

ØD1	Artikelnummer Part number	Webcode www.simtek.com/webcode	h1	h2	f2	L1	L2	Schraube Screw	Schraubenschlüssel Screw driver	Connectcode www.simtek.com/ccode	Adaptcode Adaptcode
mm			mm	mm	mm	mm	mm				
32,0	TOA.00C3 R/L	R AAAD L AJUB	31,6	12,95	4,2	36,0	46,0	TM5x15 T20R	T20R	-	R: TOA.R L: TOA.L <small>upd</small>
40,0	TOA.00C4 R/L	R AAXØ L AEEX	31,6	12,95	4,2	40,0	50,0	TM5x15 T20R	T20R	-	R: TOA.R L: TOA.L <small>upd</small>
50,0	TOA.00C5 R/L	R AEN3 L AKM8	31,6	12,95	4,2	40,0	50,0	TM5x15 T20R	T20R	-	R: TOA.R L: TOA.L <small>upd</small>
63,0	TOA.00C6 R/L	R AFJP L APM3	31,6	12,95	4,2	42,0	52,0	TM5x15 T20R	T20R	-	R: TOA.R L: TOA.L <small>upd</small>

Bestellbeispiel // Order example: **TOA.00C4 R** (R = Rechte Ausführung // Right hand version)

Technische Änderungen vorbehalten
Technical changes reserved

Die Stabilität der Kühlmitteldüse sollte regelmäßig überprüft werden.
The stability of the coolant nozzle should be checked regularly.

Modularer Grundhalter mit Polygonschaft nach ISO 26623, Axiale Bearbeitung

SIMTEK Trägerwerkzeug mit Polygonschaft aus Stahl nach ISO 26623 für TOA-Kassetten.

Modular Base Toolholder with Polygon Shank According to ISO 26623, Face Application

SIMTEK toolholder with polygon shank according to ISO 26623 for TOA-cassettes.

Anzugsmoment (Schraube) // Tightening torque (screw)

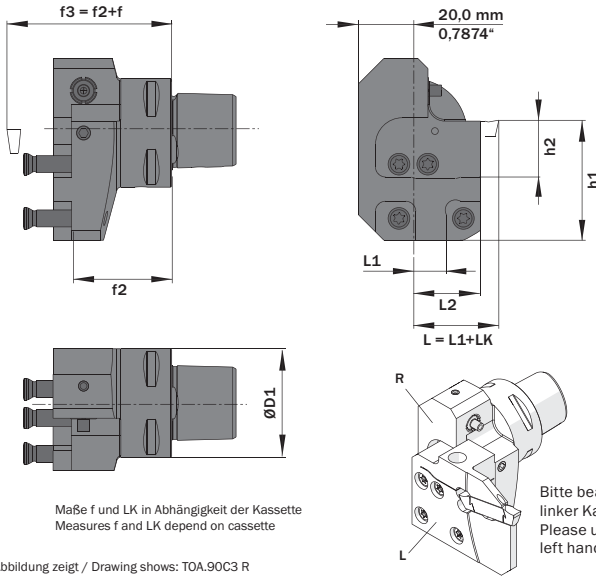
7,0 Nm



Legende Legend **428**

Scan QR-Code

Oder besuchen Sie // Or Visit www.simtek.info/cp/335



Maße f und LK in Abhängigkeit der Kassette
Measures f and LK depend on cassette

Abbildung zeigt / Drawing shows: TOA.90C3 R

Passende Kassetten // Available cassettes

simturn GX
Seite/Page 297, Seite/Page 299, Seite/Page 301

simturn E3
Seite/Page 327

simturn E12
Seite/Page 367

simturn FX
Seite/Page 397, Seite/Page 398, Seite/Page 399

Bitte beachten: Rechter Grundhalter wird mit linker Kassette bestückt und umgekehrt.
Please use right hand base toolholder with left hand cassette and vice versa.

ØD1 mm	Artikelnummer Part number	Webcode www.simtek.com/webcode	h1 mm	h2 mm	f2 mm	L1 mm	L2 mm	Schraube Screw	Schraubenschlüssel Screw driver	Connectcode www.simtek.com/ccode	Adaptcode Adaptcode
32,0	TOA.90C3 R/L	R ACFP L ABCU	31,6	12,95	29,5	10,0	20,0	TM5x15T20R	T20R	-	R: TOA.L L: TOA.R <small>upd</small>
40,0	TOA.90C4 R/L	R AJVH L AA0D	31,6	12,95	34,5	10,0	20,0	TM5x15T20R	T20R	-	R: TOA.L L: TOA.R <small>upd</small>
50,0	TOA.90C5 R/L	R ANCY L APMN	31,6	12,95	34,5	10,0	20,0	TM5x15T20R	T20R	-	R: TOA.L L: TOA.R <small>upd</small>
63,0	TOA.90C6 R/L	R AE57 L ADQ6	31,6	12,95	36,5	10,0	20,0	TM5x15T20R	T20R	-	R: TOA.L L: TOA.R

Bestellbeispiel // Order example: **TOA.90C5 R** (R = Rechte Ausführung // Right hand version)

Technische Änderungen vorbehalten
Technical changes reserved

Die Stabilität der Kühlmitteldüse sollte regelmäßig überprüft werden.
The stability of the coolant nozzle should be checked regularly.

Info

Legende
Legend

TW Trägerwerkzeug aus Stahl // Steel toolholder // Porte-outils en acier // Porta inserto in acciaio
ST Porta-herramientas de acero // Çelik tutucu

R Rechts wie gezeichnet // Right hand version shown, left hand version inversely // A droite comme présenté // In figura utensile destro
 Modelo derecho // Sağ model

 Innere Kühlmittelzufuhr // Through coolant // Refroidissement interne // Lubrificazione interna
 Con refrigeración interna // İçten soğutmalı

Index

simturn OA Produktverzeichnis
simturn OA Product list

Artikelnr. // Part Nr.	S/P
TOA.00C3 L	426
TOA.00C3 R	426
TOA.00C4 L	426
TOA.00C4 R	426
TOA.00C5 L	426
TOA.00C5 R	426
TOA.00C6 L	426
TOA.00C6 R	426
TOA.90C3 L	427
TOA.90C3 R	427
TOA.90C4 L	427
TOA.90C4 R	427
TOA.90C5 L	427
TOA.90C5 R	427
TOA.90C6 L	427
TOA.90C6 R	427

Informationen zu den Schnittparametern Information About The Cutting Parameters

Schnittgeschwindigkeiten ab Seite
Cutting speed recommendation as of page

430

Allgemeine Informationen zu den empfohlenen Schnittparametern General information about the cutting parameters recommendations

Alle angegebenen Vorschubs- und Schnittgeschwindigkeitswerte sind als allgemeine Startwerte bei mittleren Bedingungen zu verstehen.

The given cutting parameters for speed and feed rates are ment as initial start values and are estimated for standard application conditions.

Die optimalsten Werte sind von verschiedensten Faktoren (bspw. Maschinenbedingungen) abhängig und können je nach Gesamtsituation über oder unter diesen Startwerten liegen.

The best parameters depend on a wide variety of machine, workpiece and tool related conditions, for example the general machine condition, and can be above or below the given start values.

Beispielhafte Einflussfaktoren und deren Auswirkung auf die Schnittparameter Example factors of influence and their effect on the cutting parameters

Werte verringern // Reduce values

Werte erhöhen // Increase values

Schwierige Maschinen- und Spannbedingungen Difficult machine and clamping conditions	Stabile Maschinen- und Spannbedingungen Solid machine and clamping conditions
Schwer zerspanbare Materialien Difficult to machine materials	Leicht zerspanbare Materialien Easy to machine materials
Hohe Auskragung (L2) Long tool reach (L2)	Kurze Auskragung (L2) Small tool reach (L2)
Ohne Spanformgeometrie No chip form geometry	Mit Spanformgeometrie With chip form geometry

Auflistung nicht vollständig // List not complete

Eignung der Schneidstoffe im Bezug zur Werkstückstoffhärte Suitability of cutting grades in relation to work piece hardness

Schneidstoff Grade	Empfohlen bis ca. Recommended up to approx.
X8*	HRC52
*T90 / *T91	HRC62
CBN	HRC65 (Je nach Anwendung // Depending on application)

Info

Schnittgeschwindigkeiten
Cutting Speed Recommendation

ISO-Gruppe ISO-Group	Empfohlener Schmelzstoff ^(*) Recommended Cutting Grade	Werkstückstoff Work piece material	Untergruppe Sub-group	Alternativer Schmelzstoff ^(*) Alternative cutting grade	Vc m/min (Start)
P	X800 X802 X804 X808	Stahl, unlegiert <i>Steel, unalloyed</i>	≤ 0,15 % C	X400 / X600	210
			0,15 - 0,4 % C	X400 / X600	190
			≥ 0,4 % C	X400 / X600	180
		Stahl, niedriglegiert (Legierungsanteil ≤ 5%) <i>Steel, low alloyed (alloying elements ≤ 5%)</i>	Nicht gehärtet <i>Non-hardened</i>	X400 / X600	170
			Vergütet <i>Hardened</i>	X400 / X600	100
		Stahl, hochlegiert (Legierungsanteil > 5%) <i>Steel, high alloyed (Alloying elements > 5%)</i>	Geglüht <i>Annealed</i>	X400 / X600	110
			Vergütet <i>Hardened</i>	X400 / X600	90
		Stahlguss <i>Castings</i>	Unlegiert <i>Unalloyed</i>	X400 / X600	150
			Niedriglegiert (Legierungsanteil ≤ 5%) <i>Low alloyed (Alloying elements ≤ 5%)</i>	X400 / X600	120
			Hochlegiert (Legierungsanteil > 5%) <i>High alloyed (Alloying elements > 5%)</i>	X400 / X600	90
M	X400 / X600 X402 / X602 X404 / X604 X408 / X608	Rostfreier Stahl Ferritisch/Martensitisch <i>Stainless Steel Ferritic/Martensitic</i>	Nicht gehärtet <i>Non-hardened</i>	*T41	150
			PH-gehärtet <i>PH-hardened</i>	*T41	110
			Gehärtet <i>Hardened</i>	*T41	110
		Rostfreier Stahl Austenitisch <i>Stainless Steel Austenitic</i>	Austenitisch <i>Austenitic</i>	*T41	140
			PH-gehärtet <i>PH-hardened</i>	*T41	100
			Superaustenitisch <i>Super Austenitic</i>	*T41	110
		Rostfreier Stahl Austenitisch-Ferritisch (Duplex) <i>Stainless Steel Austenitic-ferritic (Duplex)</i>	Nicht Schweißbar ≥ 0,05 % C <i>Non-weldable ≥ 0,05 % C</i>	*T41	120
			Schweißbar < 0,05 % C <i>Weldable < 0,05 % C</i>	*T41	100
		Rostfreier Stahl (gegossen) Ferritisch/martensitisch <i>Stainless Steel (Cast) Ferritic/martensitic</i>	Nicht gehärtet <i>Non-hardened</i>	*T41	130
			PH-gehärtet <i>PH-hardened</i>	*T41	90
			Gehärtet <i>Hardened</i>	*T41	100
		Rostfreier Stahl (gegossen) Austenitisch <i>Stainless Steel (Cast) Austenitic</i>	Austenitisch <i>Austenitic</i>	*T41	130
			PH-gehärtet <i>PH-hardened</i>	*T41	90
		Rostfreier Stahl (gegossen) Austenitisch-Ferritisch (Duplex) <i>Stainless Steel (Cast) Austenitic-ferritic (Duplex)</i>	Nicht schweißbar ≥ 0,05 % C <i>Non-weldable ≥ 0,05 % C</i>	*T41	110
Schweißbar < 0,05 % C <i>Weldable < 0,05 % C</i>	*T41		90		

Info

Schnittgeschwindigkeiten Cutting Speed Recommendation

ISO-Gruppe ISO-Group	Empfohlener Schnittstoff ⁽²⁾ Recommended Cutting Grade	Werkstückstoff Work piece material	Untergruppe Sub-group	Alternativer Schnittstoff ⁽²⁾ Alternative cutting grade	Vc m/min (Start)	
K	X800 X802 X804 X808	Temperguß <i>Malleable</i>	Ferritisch (kurzspanend) <i>Ferritic (short chipping)</i>	*T57	180	
			Perlitisch (langspanend) <i>Pearlitic (long chipping)</i>	*T57	150	
		Grauguß <i>Grey Cast Iron</i>	Niedrige Festigkeit <i>Low tensile strength</i>	*T57	200	
			Hohe Festigkeit <i>High tensile strength</i>	*T57	150	
		Kugelgraphitguß <i>Spheroidal Graphite cast iron</i>	Ferritisch <i>Ferritic</i>	*T57	120	
			Perlitisch <i>Pearlitic</i>	*T57	110	
	Martensitisch <i>Martensitic</i>		*T57	110		
	N	X400 / X600 X402 / X602 X404 / X604 X408 / X608	Aluminiumlegierung, geschmiedet <i>Aluminium alloys, Whrought</i>	Nicht aushärtbar <i>Can not be hardened</i>	*F25	590
				Aushärtbar, Gehärtet <i>Can be hardened, hardened</i>	*F25	530
Aluminiumlegierung, gegossen <i>Aluminium alloys, Cast</i>			Nicht aushärtbar <i>Can not be hardened</i>	*F25	590	
			Aushärtbar, Gehärtet <i>Can be hardened, hardened</i>	*F25	530	
Aluminiumlegierung, gegossen <i>Aluminium alloys, Cast</i>			< 5 % Si	*F25	240	
			5 - 12 % Si	*X17	240	
		> 12 % Si	PKD ¹	180		
Kupfer- und Kupferlegierung <i>Copper- and Copper Alloys</i>		Automatenlegierung, ≥1 % Pb <i>Free Cutting Alloys, ≥1 % Pb</i>	*F25	290		
		Messing, Bleilegierung ≤ 1 % Pb <i>Brass, leaded bronzes, ≤ 1 % Pb</i>	*F25	290		
		Bronze, bleifreies Kupfer einschl. Elektrolytkupfer <i>Bronze, lead-free copper incl. electrolytic copper</i>	*F25	210		

simturn AX

simturn DX

simturn PX

simturn H2

simturn K2

simturn C4

simturn GX

simturn E3

simturn E12

simturn FX

simturn Decolletage

simturn OA

Index

431

Schnittgeschwindigkeiten Cutting Speed Recommendation

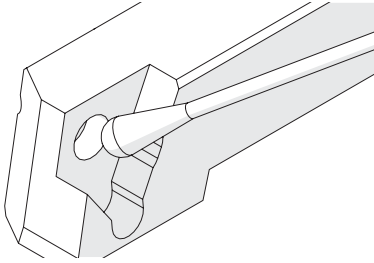
ISO-Gruppe ISO-Group	Empfohlener Schneidstoff ⁽²⁾ Recommended Cutting Grade	Werkstückstoff Work piece material	Untergruppe Sub-group	Alternativer Schneidstoff ⁽²⁾ Alternative cutting grade	Vc m/min (Start)	
S	X400 / X600 X402 / X602 X404 / X604 X408 / X608	Warmfeste Superlegierungen Fe-basiert <i>Heat-resistant super alloys Fe-based</i>	Geglüht oder lösungsbehandelt <i>Annealed or solution treated</i>	*X79	40	
			Ausgehärtet oder lösungsbehandelt und ausgehärtet <i>Aged or solution treated and aged</i>	*X79	30	
		Warmfeste Superlegierungen Ni-basiert <i>Heat-resistant super alloys Ni-based</i>	Geglüht oder lösungsbehandelt <i>Annealed or solution treated</i>	*X79	40	
			Ausgehärtet oder lösungsbehandelt und ausgehärtet <i>Aged or solution treated and aged</i>	*X79	20	
			Gegossen oder gegossen und ausgehärtet <i>Cast or Cast and aged</i>	*X79	30	
		Warmfeste Superlegierungen Co-basiert <i>Heat-resistant super alloys Co-based</i>	Geglüht oder lösungsbehandelt <i>Annealed or solution treated</i>	*X79	10	
			Lösungsbehandelt und ausgehärtet <i>Solution treated and aged</i>	*X79	10	
		Titanlegierung <i>Titanium Alloys</i>	Gegossen oder gegossen und ausgehärtet <i>Cast or Cast and aged</i>	*X79	10	
			Handelsüblich rein (99,5 % Ti) <i>Commercial pure (99,5 % Ti)</i>	*X79	80	
			α, ähnlich α und α + β Legierungen, geglüht <i>α, near α and α + β alloys, annealed</i>	*X79	40	
				α+β Legierungen in ausgehärtetem Zustand sowie β Legierungen. Geglüht oder ausgehärtet <i>α+β Alloys in aged conditions as well as β alloys. Annealed or aged.</i>	*X79	40
		H	CBN ¹	Gehärtete Stähle <i>Hardened steel</i>		*T91
Kokillenhartguß, gegossen oder gegossen und ausgehärtet <i>Chilled cast iron, cast or cast and aged</i>				*T91	90	

(1) Zusätzlich wird eine besondere Schneidengeometrie für beste Ergebnisse empfohlen. Bitte kontaktieren Sie im Bedarfsfall unseren technischen Support +49 7473 9517-140 oder support@simtek.com. For best results, a special cutting edge geometry is recommended here. Please contact our technical support +49 7473 9517-140 oder support@simtek.com.

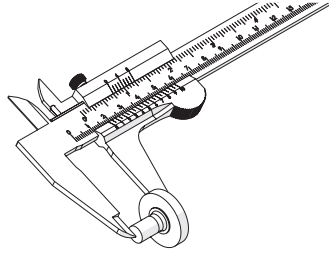
(2) Schneidstoffempfehlung ist abhängig vom jeweiligen Schneidwerkzeug. Den passenden Schneidstoff entnehmen Sie bitte der jeweiligen Katalogseite des gewünschten Schneidwerkzeugs. // Recommendation depends on the chosen cutting inserts. Please look at the cutting grade recommendations on the catalog page of the cutting insert.

Info

Allgemeine Gebrauchshinweise General Instructions For Use



Bitte reinigen Sie den Plattensitz sorgfältig vor Gebrauch.
Please clean insert seat well before mounting and use.



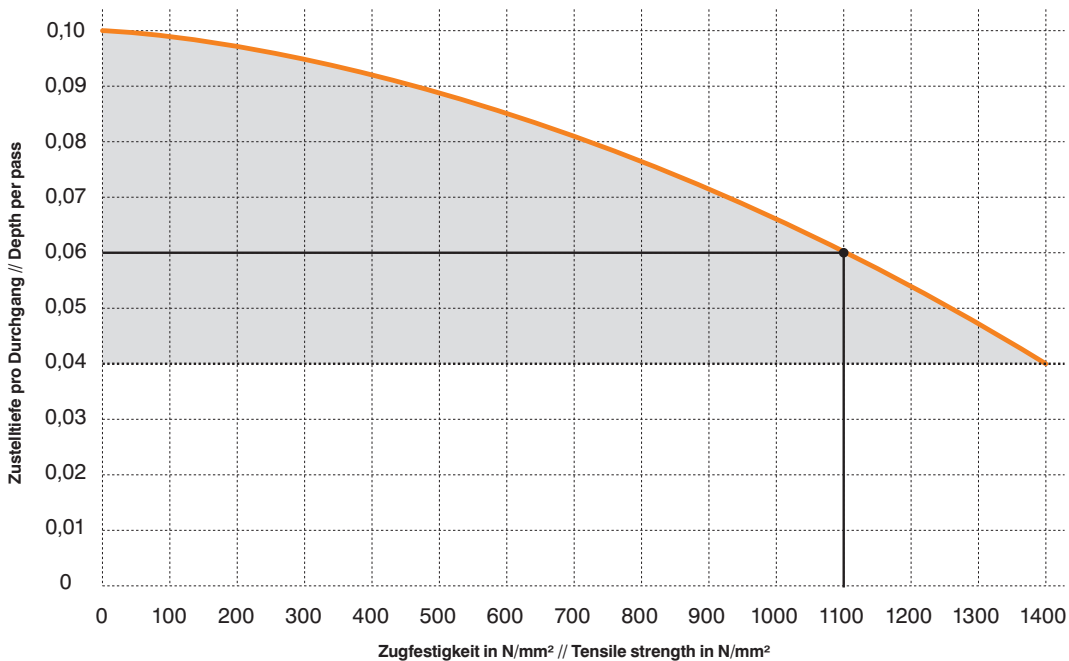
Bitte prüfen Sie Ihre Werkstücke regelmäßig.
Please control your work pieces frequently.



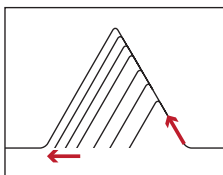
Wir empfehlen den Einsatz von Werkzeug-Voreinstellgeräten.
We recommend the use of tool presetting and measuring devices.

Gewinden: Zustellung pro Durchgang in Abhängigkeit der Zugfestigkeit Threading: Infeed per pass in dependence of the tensile strength

Beispiel: Zustellung 0,06 mm/Durchgang bei 1100N/mm² Zugfestigkeit
Example: Infeed 0,06 mm/ pass if tensile strength is 1100 N/mm²



Unsere Empfehlung: Flankenzustellung
Our recommendation: Flank infeed



Die Flankenzustellung kann degressiv oder konstant, mit ein bis zwei abschließenden Schlichschnitten, ausgeführt werden. Hierbei ist zu beachten, dass die kleinste Zustellung von 0,04mm nicht unterschritten werden sollte.

The flank infeed can be degressive or constant, with one or two final finishing cuts. Please note that the smallest infeed should not subceed 0,04mm.

simmill
SIMTEK MILLING TOOLS

Info

Die simmill Zirkularfräswerkzeuge The simmill Groove Milling Tools

simmillAX
SIMTEK milling tools type AX

Zirkularfräswerkzeuge für die Innenbearbeitung im Durchmesserbereich ...

Groove milling tools for internal applications in the diameter range of ...

≤ Ø 11,0 mm



Seite // Page

441

simmillPMX|PX|SX|UX|VX
SIMTEK milling tools type PMX|PX|SX|UX|VX

Zirkularfräswerkzeuge für die Innenbearbeitung im Durchmesserbereich ...

Groove milling tools for internal applications in the diameter range of ...

Ø 7,0 – 40,0 mm



Seite // Page

454

Ein Verzeichnis aller Werkzeuge finden Sie ab Seite 651
A list of all the tools can be found as of page 651

Info

Die simmill Zirkularfräswerkzeuge The simmill Groove Milling Tools

simmillH2

SIMTEK milling tools type H2

Aktives Spannsystem für 3,6-fache Frästiefen* mit einem Schneidkreis von ...

Active clamping system for 3,6 times higher cutting depths* with cutting diameter of ...

* im Vergleich zu // Compared to simmill MX

Ø 100,0 mm



Seite // Page

601

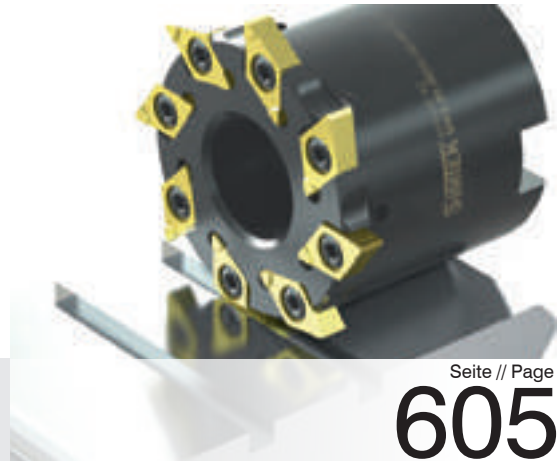
simmillK2

SIMTEK milling tools type K2

Zirkularfräswerkzeuge für die Innenbearbeitung im Durchmesserbereich ...

Groove milling tools for internal applications in the diameter range of ...

≥ Ø 39,0 mm



Seite // Page

605

simmillMX

SIMTEK milling tools type MX

Zirkularfräswerkzeuge für die Innenbearbeitung im Durchmesserbereich ...

Groove milling tools for internal applications in the diameter range of ...

≥ Ø 39,0 mm



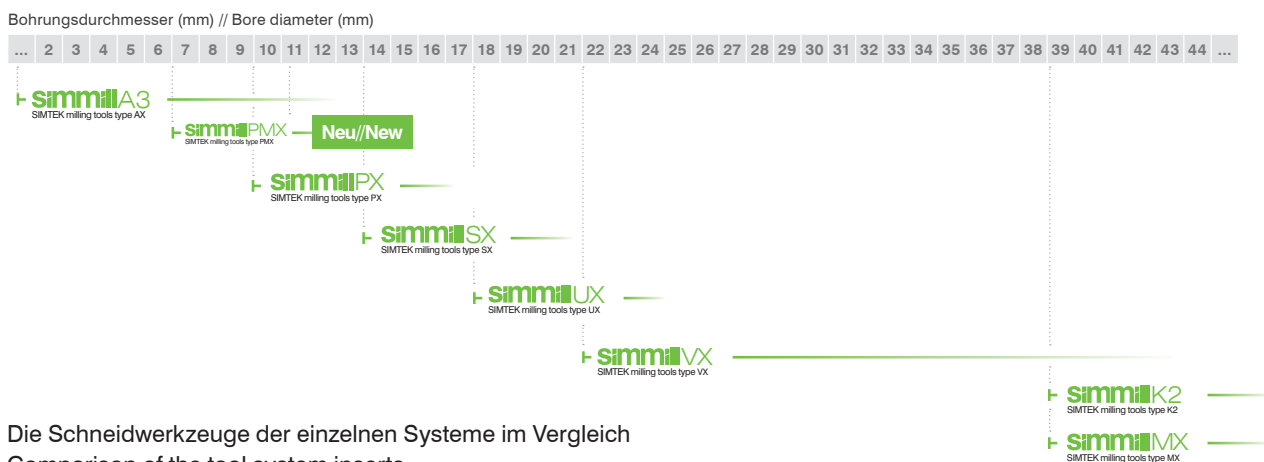
Seite // Page

611

Ein Verzeichnis aller Werkzeuge finden Sie ab Seite 651
A list of all the tools can be found as of page 651

Die Zirkularfräs-Werkzeugsysteme im Vergleich The Groove Milling Tool System comparison

Vergleich der Werkzeugsystemeignung bei der Innenbearbeitung (bezogen auf den Bohrungsdurchmesser)
Comparison of the tool systems suitability for internal applications (based on work piece bore diameter)



Die Schneidwerkzeuge der einzelnen Systeme im Vergleich
Comparison of the tool system inserts

		2 Schneiden 2 cutting edge	3 Schneiden 3 cutting edges	4 Schneiden 4 cutting edges	6 Schneiden 6 cutting edges
Geeignet ab Bohrungsdurchmesser // For use as of minimum bore diameter	<Ø 6,0 mm	-	MA3 simmill A3	MA4 simmill A4	-
	Ø 8,0 mm	-	MA3 simmill A3	-	-
	Ø 10,0 mm	-	P10 simmill PX	-	P06...10 simmill PX
	Ø 12,0 mm	-	P12 simmill PX	-	P06...12 simmill PX
	Ø 14,0 mm	-	S14 simmill SX	-	S06...14 simmill SX
	Ø 16,0 mm	-	S16 simmill SX	-	S06...16 simmill SX
	Ø 18,0 mm	-	U18 simmill UX	-	U06...18 simmill UX
	Ø 20,0 mm	-	U20 simmill UX	-	-
	Ø 20,0 mm	-	V20 simmill VX	-	U06...20 simmill UX
	Ø 22,0 mm	-	V22 simmill VX	-	V06...22 simmill VX
	Ø 25,0 mm	-	V25 simmill VX	-	V06...25 simmill VX
	Ø 28,0 mm	-	V28 simmill VX	-	V06...28 simmill VX
	Ø 32,0 mm	-	V32 simmill VX	-	-
	Ø 33,0 mm	-	V33 simmill VX	-	-
	Ø 35,0 mm	-	-	-	V06...35 simmill VX
	Ø 37,0 mm	-	-	-	V06...37 simmill VX
	Ø 39,0 mm	MK2 simmill K2	MX simmill MX	-	-



simmill AX
simmill PMX
simmill PX
simmill SX
simmill UX
simmill VX
simmill H2
simmill K2
simmill MX
simmill OS
Index

Im PDF-Katalog sind alle Webcodes und Querverweise verlinkt.
Per Klick gelangen Sie darüber zu den verknüpften Informationen.

The Webcodes and cross-references are interactive links in the PDF-catalog.
A click on these links leads to the connected information.

Zur Nutzung des Katalogs // Using the catalog

Der Webcode und weitere Querverweise The Webcode and more cross-references

Der **Webcode**, in jeder Katalogseitenzeile
The **Webcode**, shown on every catalog page line

Der Webcode stellt eine eindeutige und schnelle Verbindung in die digitale Welt dar. Verwenden Sie den Webcode u.a. im Internet um tagesaktuelle Informationen zu erhalten.

The Webcode is a unique and fast connection between our part numbers and the digital world. Use it on our website and get up-to-date information fast, easy and reliable.

<http://www.simtek.com/webcode/>

Der Webcode besteht im Standardbereich aus einem alphanumerischen vierstelligen Code. Dieser Code beschreibt jeden Artikel eindeutig:

The Webcode is a four digit alphanumeric code which is available for every standard item.
This code is unique for every item:

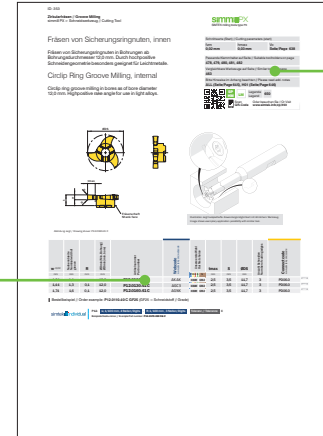
V06.0100.010.28 G		=	AASZ X800	
Artikel Item	Schneidstoff Grade		Webcode	Schneidstoff Grade

Beispiel // Example

Gerne können Sie diesen Webcode auch zur Bestellung verwenden. Hängen Sie dazu im Bestellfall - wie bei Schneidwerkzeugen gewohnt - noch den gewünschten Schneidstoff an.

You can also use this Webcode for your ordering process. Just add the grade code - if ordering a cutting insert - and the short ordering code is complete.

Zusätzliche **Querverweise** und **Informationen**, auf jeder Katalogseite
Extra **cross-references** and **information**, shown on every catalog page



Schnittwerte (Start) // Cutting parameters (start)		
fzm 0,02 mm	hmax 0,03 mm	Vc Seite/Page 638

Passende Klemmhalter auf Seite // Suitable toolholders on page
478, 479, 480, 481, 482

Vergleichbare Werkzeuge auf Seite // Similar tools on page
463

Bitte Hinweise im Anhang beachten // Please read add. notes
ALL (Seite/Page 645), H01 (Seite/Page 646)

				Legende Legend	650
Scan QR-Code		Oder besuchen Sie // Or Visit www.simtek.info/cp/353			

Im rechten oberen Bereich erhalten Sie zusätzliche Querverweise angezeigt. Diese führen zu passenden Trägerwerkzeugen, vergleichbaren Werkzeugen, Schnittwerten und weiterführenden Hinweisen. Die entsprechenden Informationen finden Sie auf den angegebenen Seitenzahlen.

You can find additional information and cross-references in the upper right corner. These cross-references lead to compatible toolholders, similar tools, cutting parameters and additional notes. The corresponding information can be found on the shown page numbers.

Der Connectcode The Connectcode

Nutzen Sie den „Connectcode“ um auf einfachste Weise zu ermitteln, welche Kombination aus Schneidwerkzeug und Werkzeugträger von uns empfohlen ist. Dieser „Connectcode“ wird sowohl bei Schneidwerkzeugen als auch bei Werkzeugträgern ausgewiesen - vorausgesetzt das System benötigt ein Trägerwerkzeug für den Einsatz.

Stimmen beide Werte überein, können Sie diese Kombination bedenkenlos einsetzen.

Andere Kombinationen sind ebenfalls möglich, jedoch können diese zu einem eingeschränkten Funktionsumfang führen.

Please use the „Connectcode“ in order to verify which combination between cutting insert and toolholder is recommended. This „Connectcode“ is shown on catalog pages of cutting inserts as well as on catalog pages of toolholders - if the tool system does not require the use of a toolholder, no „Connectcode“ is given.

Identical values indicate that the combination of insert and toolholder is recommended.

Different combinations can be possible too at the possible expense of other tool characteristics.

Connectcode www.simtek.com/connectcode	Schneidwerkzeug // Cutting tool															
	M14.L.6.0	M14.R.6.0	M82.3.2	M82.4.3	M82.5.4	PD*	PD06.0	SD*	SD08.0	UD*	UD09.0	VD09.0	VD1*	VD12.0	VD14.3	
M14.L.6.0	●															
M14.R.6.0		●														
M82.3.2			●													
M82.4.3				●												
M82.5.4					●											
PD06.0						●	●									
PD07.3						●	○									
SD08.0								●	●							
SD09.5								●	○							
UD09.0										●	●					
UD12.0										●	○					
UD13.0										●	○					
VD09.0												●	○	○	○	
VD11.3												○	●	○	○	
VD11.5												○	●	○	○	
VD12.0												○	●	●	○	
VD12.7												○	●	○	○	
VD13.5												○	●	○	○	
VD14.0												○	●	○	○	
VD14.3												○	●	○	●	
VD15.0												○	●	○	○	
VD16.0												○	●	○	○	

- Empfohlene Kombination // Recommended combination
- Baulich mögliche Kombination, mit abweichendem Funktionsumfang // Constructionally possible combination but with differing functionality

Die obige Tabelle zeigt die in diesem Katalog verwendeten „Connectcodes“ an. Ein ausgefüllter grüner Punkt in der Schnittstelle steht für eine vollständige Kompatibilität.

This table contains all the „Connectcodes“ from this catalog. A full green circle on the intersection of cutting tool and toolholder indicates that the connection of both items is recommended.

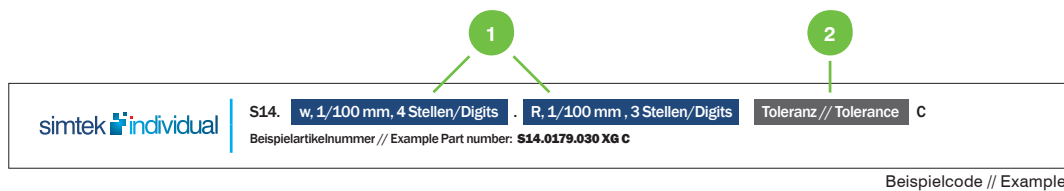
Werkzeuge nach Ihrem Bedarf Tools according to your need

Werkzeuge nach Ihrem Bedarf:
Ganz einfach mit simtek-individual.

Tools according to your need:
Very easy with simtek-individual.

Einige Katalogseiten weisen einen simtek-individual-Schlüssel auf. Nutzen Sie diesen in der unten angegebenen Weise um eine Artikelnummer für ein Werkzeug nach Ihrem Bedarf zu erstellen.

Some catalog pages show a simtek-individual-key. Use this code as stated below in order to create a part number that represents a tool according to your need.



1 Der angegebenen Code ist eine Vorlage. Ersetzen Sie die blau hinterlegten Platzhalter durch die von Ihnen gewünschten Maße.

The given code on the catalog page is a template. Replace the blue fields with the measures you require.

2 Bestimmen Sie die Schneidenbreitentoleranz durch das Anhängen des Toleranzklassen-codes. Die verfügbaren Toleranzklassen sind:

Define the required cutting edge width tolerance by adding the right tolerance class code. These tolerance classes are available:

Toleranzklassen-Code Tolerance Class Code	XG	XN	XE
Schneidenbreitentoleranz Tolerance of the cutting edge width	±0,01 mm	±0,02 mm	-0,03 mm

Beispiel auf Basis des obigen simtek-individual-Schlüssels
Example based on the above simtek-individual-key

S14. 0179 .035 XG C

Gewünschte Schneidenbreite (w) Required cutting edge width (w)	1,79 mm	0179
Gewünschte Eckenradien (R) Required corner radius (R)	0,35 mm	035
Gewünschte Schneidenbreitentoleranz Required tolerance of the cutting edge width	±0,01 mm	XG

3 Nutzen Sie den erstellten Code um damit Preis und Lieferzeit per E-Mail anzufragen:

Contact us via E-Mail for current price and delivery time using the created code:

offer@simtek.com

Info

Das Werkzeugsystem simmill AX The Tool System simmill AX

- + Schafffräser aus Feinstkornhartmetall
in den Schaftdurchmessern 6,0 oder 8,0 mm
Solid micro grain carbide milling cutter
with shank diameters 6,0 or 8,0 mm
- + Hohe Nutttiefen in kleinsten Bohrungen
High groove depths in smallest bores
- + Verbesserte Schnittbedingungen
mit 3 Schneiden in Bohrungen ab Ø 1,4 mm
Improved cutting conditions
with 3 cutting edges in bores as of Ø 1,4 mm
- + Hohe Gewindetiefen bei reduziertem Schnittdruck
Extended thread depths at low cutting pressure
- + Nutzbare Länge bis zu 35,6 mm
Usable length up to 35,6 mm

Hauptanwendungen

Nutfräsen, Gewindefräsen, Bohrungen fassen,
Fräsen von Scheibenfedernuten

simtek-individual- und
Individualwerkzeuge verfügbar.

Main applications

Groove milling, thread milling,
chamfering, key way milling

simtek-individual and
customized tools available.

simmill AX
SIMTEK milling tools type AX



simmill AX

simmill PMX

simmill PX

simmill SX

simmill UX

simmill VX

simmill H2

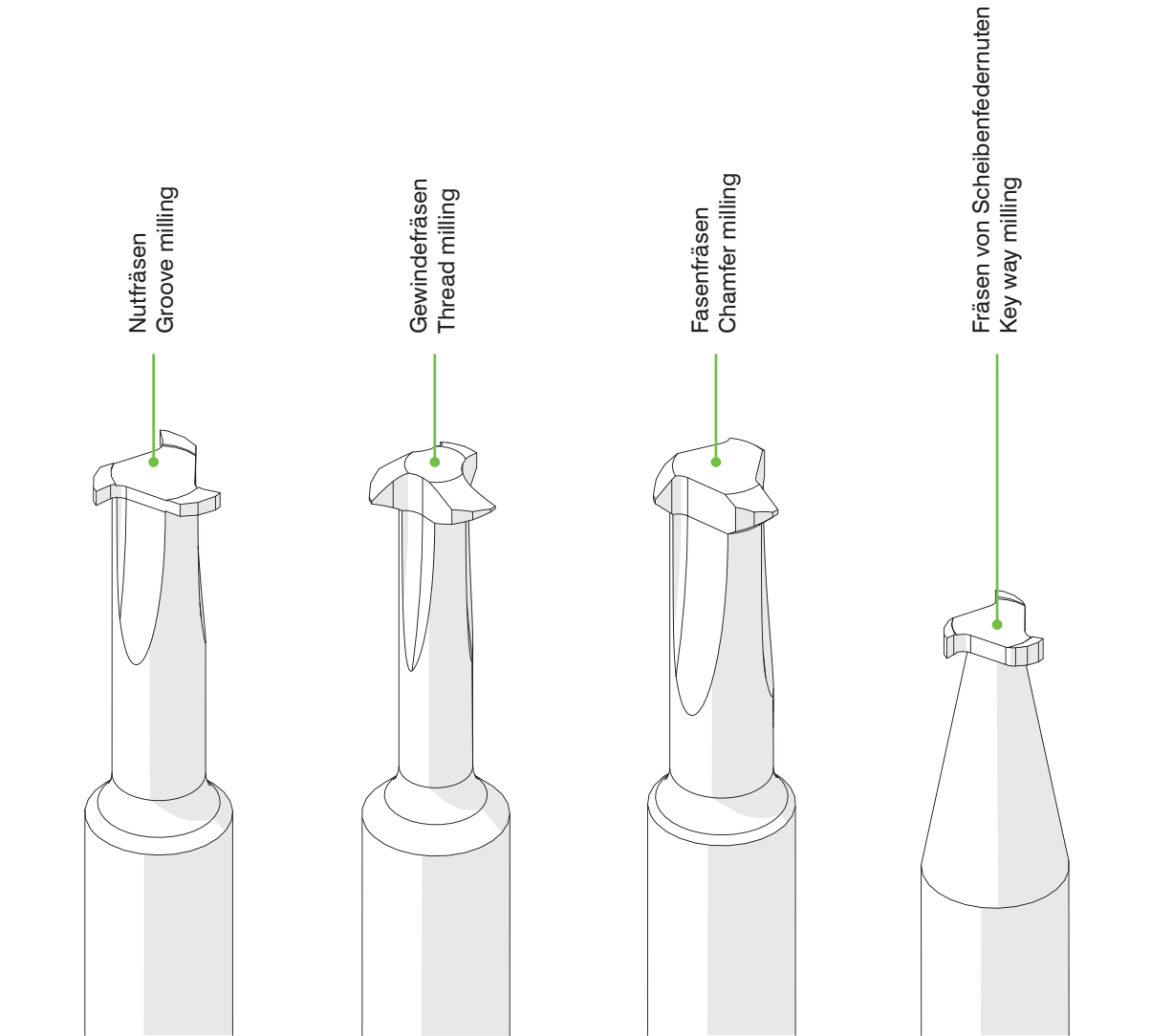
simmill K2

simmill MX

simmill OS

Index

441



... finden Sie ab Seite:

... can be found as of page:

443

446

452

453

Allgemeines Nutfräsen

Nutfräsen gerader Nutformen. Geeignet ab Bohrungsdurchmesser 6,0 mm. Aufnahme nach DIN 6535 HA.

General Groove Milling

General Groove Milling. For use in bores as of minimum bore diameter 6,0 mm. Shank according to DIN 6535 HA.

Schnittwerte (Start) // Cutting parameters (Start)		
fzm 0,02 mm	hmax 0,03 mm	Vc Seite/Page 639

Bitte Hinweise im Anhang beachten // Please read add. notes
ALL (Seite/Page 645), H07 (Seite/Page 648)

SP Legende
HM Legend

Scan
 Oder besuchen Sie // Or Visit
www.simtek.info/cp/291

650

Weldo-Aufnahme auf Anfrage erhältlich.
Weldo fixation available upon request.

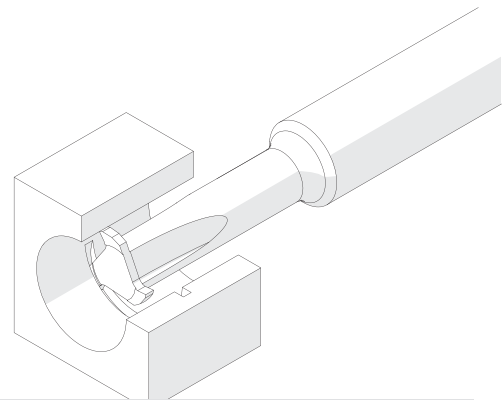
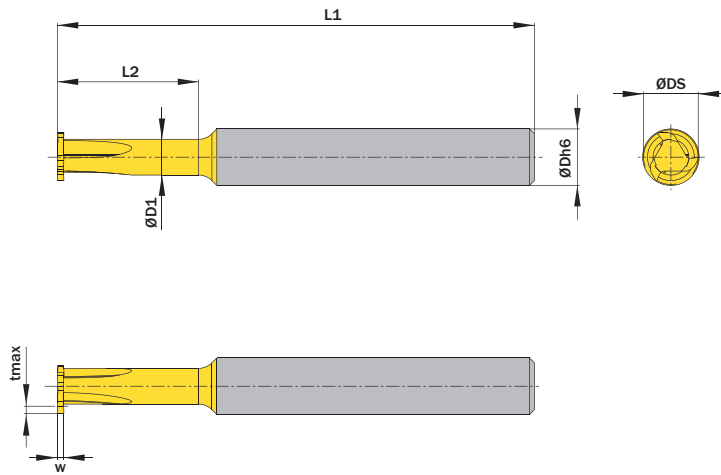


Illustration zeigt beispielhafte Anwendungsmöglichkeit mit ähnlichem Werkzeug.
Image shows exemplary application possibility with similar tool.

Abbildung zeigt / Drawing shows: MA3.070.15.06.00 AG

w ±0,02	L2	ØDmin (Min. Bohrung) ØDmin (min. bore)	Artikelnummer Part number	Webcode www.simtek.com/webcode	Unsere erste Wahl Our first choice	ZEFP	ØD1	ØDh6	ØDS	L1	tmax	Connectcode www.simtek.com/ccode
mm	mm	mm			P M K N S		mm	mm	mm	mm	mm	
▼ ØDmin (Min. Bohrung) // ØDmin (min. bore) = 6,0 mm												
0,5	15,0	6,0	MA3.050.15.06.00 AG	AVT1	X800 GT42	3	3,8	6,0	5,8	58,0	0,8	-
0,6	15,0	6,0	MA3.060.15.06.00 AG	AVT3	X800 GT42	3	3,8	6,0	5,8	58,0	0,8	-
0,7	15,0	6,0	MA3.070.15.06.00 AG	ACW4	X800 GT42	3	3,8	6,0	5,8	58,0	0,8	-
0,8	15,0	6,0	MA3.080.15.06.00 AG	AM62	X800 GT42	3	3,8	6,0	5,8	58,0	0,8	-
0,9	15,0	6,0	MA3.090.15.06.00 AG	AF94	X800 GT42	3	3,8	6,0	5,8	58,0	0,8	-
1,0	15,0	6,0	MA3.100.15.06.00 AG	AAZ2	X800 GT42	3	3,8	6,0	5,8	58,0	0,8	-
1,5	15,0	6,0	MA3.150.15.06.00 AG	AN5F	X800 GT42	3	3,8	6,0	5,8	58,0	0,8	-
▼ ØDmin (Min. Bohrung) // ØDmin (min. bore) = 8,0 mm												
0,7	25,0	8,0	MA3.070.25.08.00 AG	AJ2V	X800 GT42	3	5,0	8,0	7,8	68,0	1,2	-
0,8	25,0	8,0	MA3.080.25.08.00 AG	AFCH	X800 GT42	3	5,0	8,0	7,8	68,0	1,2	-
0,9	25,0	8,0	MA3.090.25.08.00 AG	AMAC	X800 GT42	3	5,0	8,0	7,8	68,0	1,2	-
1,0	25,0	8,0	MA3.100.25.08.00 AG	ANEA	X800 GT42	3	5,0	8,0	7,8	68,0	1,2	-
1,5	25,0	8,0	MA3.150.25.08.00 AG	AF41	X800 GT42	3	5,0	8,0	7,8	68,0	1,2	-
2,0	25,0	8,0	MA3.200.25.08.00 AG	AFXV	X800 GT42	3	5,0	8,0	7,8	68,0	1,2	-

Bestellbeispiel // Order example: **MA3.200.25.08.00 AG X800** (X800 = Schneidstoff // Grade)



MA3. w, 1/100 mm, 3 Stellen/Digits .15.06. R, 1/100 mm, 3 Stellen/Digits .A Toleranz // Tolerance
Beispielartikelnummer // Example Part number: **MA3.179.15.06.030.A XG**



MA3. w, 1/100 mm, 3 Stellen/Digits .25.08. R, 1/100 mm, 3 Stellen/Digits .A Toleranz // Tolerance
Beispielartikelnummer // Example Part number: **MA3.179.25.08.030.A XG**

simmill AX
simmill PMX
simmill PX
simmill SX
simmill UX
simmill VX
simmill H2
simmill K2
simmill MX
simmill OS
Index

Fräsen von Vollradiusnuten

Nutfräsen runder Nutformen. Geeignet ab Bohrungsdurchmesser 4,0 mm. Aufnahme nach DIN 6535 HA.

Full Radius Groove Milling

Full radius groove milling. For use in bores as of minimum bore diameter 4,0 mm. Shank according to DIN 6535 HA.

Schnittwerte (Start) // Cutting parameters (Start)

fzm 0,02 mm	hmax 0,03 mm	Vc Seite/Page 638
-----------------------	------------------------	-----------------------------

Bitte Hinweise im Anhang beachten // Please read add. notes

ALL (Seite/Page 645), H07 (Seite/Page 648)



SP Legende
HM Legend

650

Scan QR-Code

Oder besuchen Sie // Or Visit
www.simtek.info/cp/1244

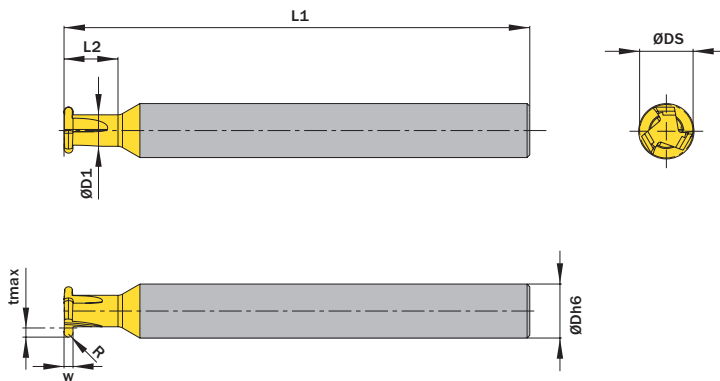


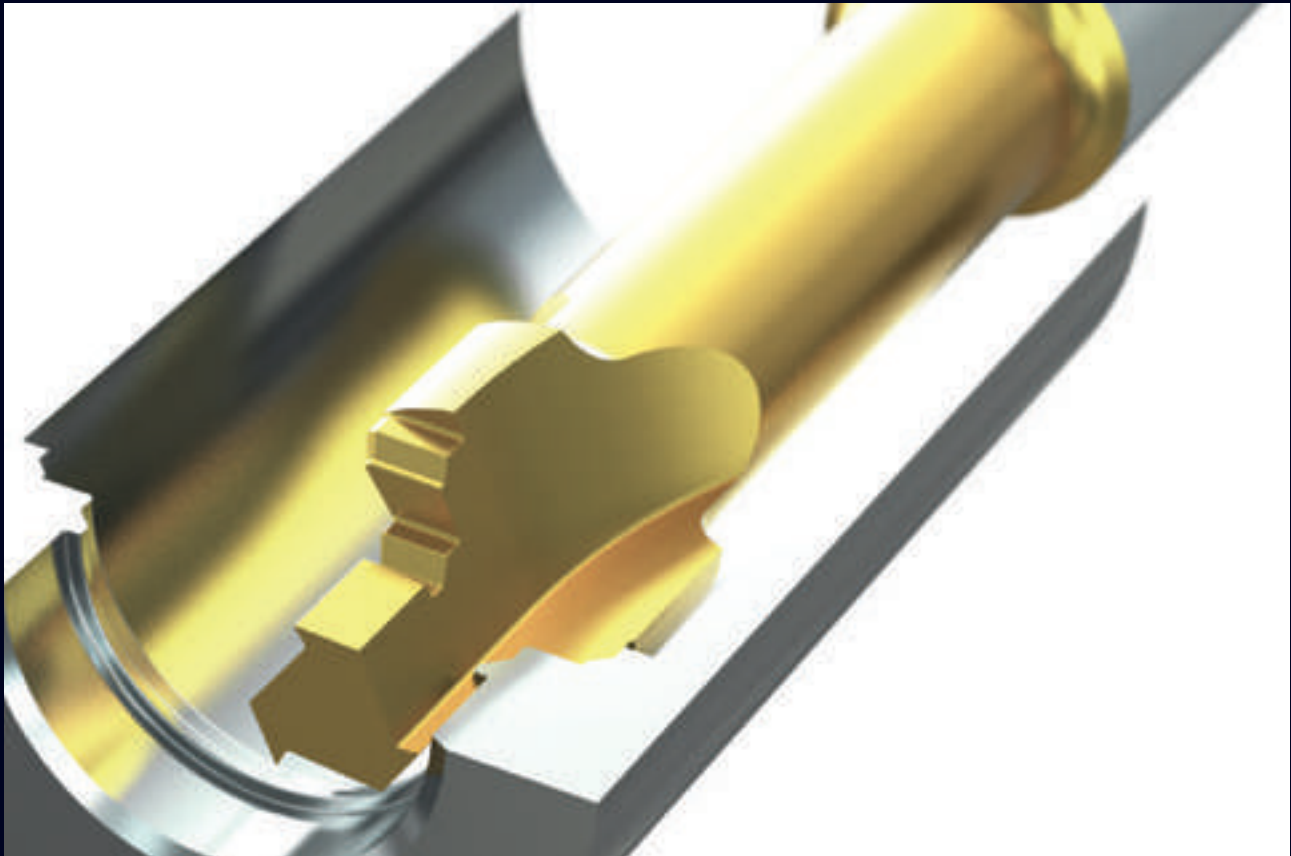
Abbildung zeigt / Drawing shows: MA3.100.06.06.05 AV

w ±0,02	L2	ØDmin (Min. Bohrung) ØDmin (min. bore)	R	Artikelnummer Part number	Webcode www.simtek.com/webcode	Unsere erste Wahl Our first choice	ZEFP	ØD1	ØDh6	ØDS	L1	tmax	Connectcode www.simtek.com/ccode
mm	mm	mm	mm			P M K N S		mm	mm	mm	mm	mm	
▼ ØDmin (Min. Bohrung) // ØDmin (min. bore) = 4,0 mm													
1,0	4,0	4,0	0,5	MA3.100.04.04.05 AV	AZ19	X800 GT42	3	2,55	6,0	3,8	58,0	0,5	-
▼ ØDmin (Min. Bohrung) // ØDmin (min. bore) = 6,0 mm													
1,0	6,0	6,0	0,5	MA3.100.06.06.05 AV	AZ18	X800 GT42	3	3,5	6,0	5,8	58,0	1,0	-
1,5	6,0	6,0	0,75	MA3.150.06.06.07 AV	AZ17	X800 GT42	3	3,5	6,0	5,8	58,0	1,0	-
▼ ØDmin (Min. Bohrung) // ØDmin (min. bore) = 8,0 mm													
1,5	16,0	8,0	0,75	MA4.150.16.08.07 AV	AZ2A	X800 GT42	4	4,4	8,0	7,8	68,0	1,5	-
2,0	16,0	8,0	1,0	MA4.200.16.08.10 AV	AZ2B	X800 GT42	4	4,4	8,0	7,8	68,0	1,5	-
▼ ØDmin (Min. Bohrung) // ØDmin (min. bore) = 10,0 mm													
1,0	20,0	10,0	0,5	MA4.100.20.10.05 AV	AZ2C	X800 GT42	4	5,3	10,0	9,8	78,0	2,0	-
1,5	20,0	10,0	0,75	MA4.150.20.10.07 AV	AZ2D	X800 GT42	4	5,3	10,0	9,8	78,0	2,0	-
2,0	20,0	10,0	1,0	MA4.200.20.10.10 AV	AZ2E	X800 GT42	4	5,3	10,0	9,8	78,0	2,0	-
2,5	20,0	10,0	1,25	MA4.250.20.10.12 AV	AZ2F	X800 GT42	4	5,3	10,0	9,8	78,0	2,0	-
3,0	20,0	10,0	1,5	MA4.300.20.10.15 AV	AZ2G	X800 GT42	4	5,3	10,0	9,8	78,0	2,0	-

Bestellbeispiel // Order example: **MA4.100.20.10.05 AV X800** (X800 = Schneidstoff // Grade)

Individualwerkzeuge // Customized tools

Kundenindividuelle Werkzeuglösungen Customer-specific tooling solutions



Fertigung einer kompletten Kontur mit simmill AX in einem Zug sorgt für eine erhebliche Hauptzeitreduktion. Die spezielle Werkzeugform sorgt für kurze Späne und dadurch für eine erhöhte Prozesssicherheit.

SIMTEK Individualwerkzeuge bieten unzählige Vorteile! Neben unserem Anspruch, jeweils die qualitativ bestmögliche Werkzeuglösung für Ihre Anwendung anzubieten, ist es auch unser Bestreben Ihnen durch ein SIMTEK Individualwerkzeug den größtmöglichen wirtschaftlichen Nutzen zu liefern! Tausende, aktuell erfolgreich eingesetzte Individualwerkzeuge bestätigen dies!

Kontaktieren Sie uns und lassen auch Sie sich von den Vorteilen mit SIMTEK Individualwerkzeugen überzeugen!

Machining of a complete contour with simmill AX in one pass results in a considerable reduction of production time. The special tool shape ensures short chips and thus increased process reliability.

SIMTEK individual tools offer countless advantages! In addition to our goal to offer the qualitatively best possible tooling solution for your application, we also aspire to provide you with the greatest possible economic benefit from a customized SIMTEK tool! Thousands of currently successfully used SIMTEK individual tools confirm this!

Contact us and convince yourself of the advantages of SIMTEK individual tools!

simmillAX
SIMTEK milling tools type AX

Metrisches ISO-Gewindefräsen, Teilprofil

Gewindefräsen ab Bohrungsdurchmesser 1,4 mm, metrisches ISO-Gewinde, Teilprofil. Aufnahme nach DIN 6535 HA.

Thread milling, Metric ISO-thread, Partial Profile

Thread milling as of bore diameter 1,4 mm, ISO metric thread, partial profile. Shank according to DIN 6535 HA.

Schnittwerte (Start) // Cutting parameters (Start)		
fzm	hmax	Vc
0,02 mm	0,03 mm	Seite/Page 638

Bitte Hinweise im Anhang beachten // Please read add. notes
ALL (Seite/Page 645), H04 (Seite/Page 648), H07 (Seite/Page 648)

SP

Legende

HM

Legend

650

Scan QR-Code Oder besuchen Sie // Or Visit
www.simtek.info/cp/294

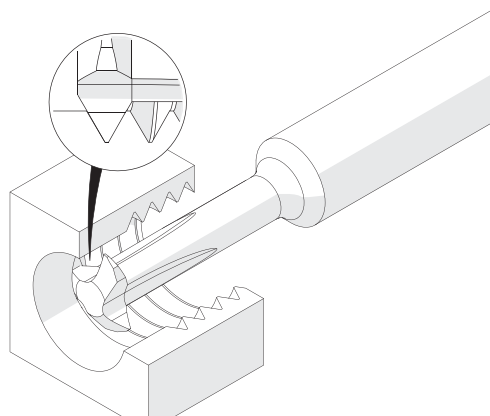
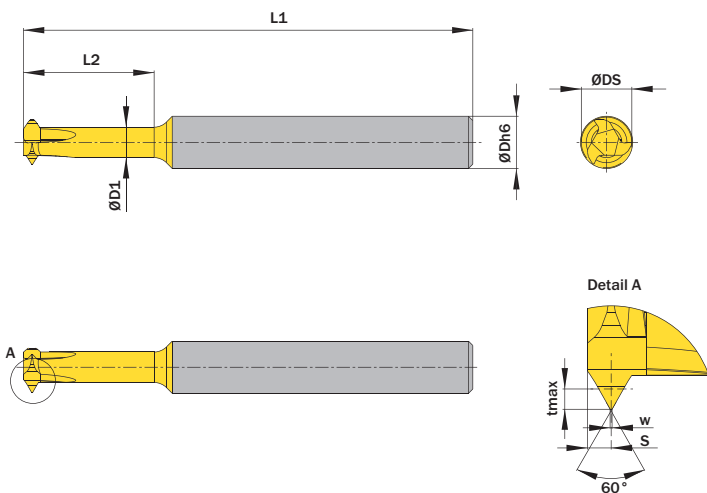


Illustration zeigt beispielhafte Anwendungsmöglichkeit mit ähnlichem Werkzeug.
Image shows exemplary application possibility with similar tool.

Abbildung zeigt / Drawing shows: MA3.MT15.01.15.06 AM

Ab Gewindegröße As of thread size	Steigung (von) Pitch (as of)	Steigung (bis) Pitch (up to)	L2	ØDh6	Artikelnummer Part number	Webcode www.simtek.com/webcode	Unsere erste Wahl Our first choice	ZEFP	ØD1	ØDmin (Min. Bohrung) ØDmin (min. bore)	ØDS	L1	tmax	w	S	Connectcode www.simtek.com/ccode
▼ ØDh6 = 3,0 mm																
M1	0,25	0,25	2,5	3,0	MA3.MT02.01.02.03 AM	A5N3	X800 GT42	3	0,33	0,75	0,7	32,0	0,14	0,03	0,2	-
M1,6	0,35	0,35	4,0	3,0	MA3.MT03.01.04.03 AM	AQ0E	X800 GT42	3	0,67	1,38	1,18	32,0	0,19	0,04	0,2	-
M1,8	0,35	0,35	5,0	3,0	MA3.MT03.01.05.03 AM	AQ0F	X800 GT42	3	0,86	1,58	1,38	32,0	0,19	0,04	0,2	-
M2,5	0,4	0,4	5,0	3,0	MA4.MT04.01.05.03 AM	AQ0G	X800 GT42	4	0,92	2,07	1,5	32,0	0,22	0,05	0,3	-
M3	0,45	0,45	6,0	3,0	MA4.MT04.01.06.03 AM	AQ0H	X800 GT42	4	1,28	2,52	1,95	32,0	0,25	0,06	0,3	-
M3,5	0,5	0,5	7,0	3,0	MA4.MT05.01.07.03 AM	AQ0J	X800 GT42	4	1,67	2,96	2,4	32,0	0,27	0,06	0,3	-
M4,0	0,6	0,6	8,0	3,0	MA4.MT06.01.08.03 AM	AQ0K	X800 GT42	4	1,93	3,35	2,8	32,0	0,33	0,08	0,4	-
▼ ØDh6 = 5,0 mm																
M4,5	0,7	0,7	9,0	5,0	MA4.MT07.01.09.05 AM	AQ0M	X800 GT42	4	2,12	3,74	3,1	44,0	0,38	0,09	0,4	-
M5,5	0,8	0,8	10,0	5,0	MA4.MT08.01.10.05 AM	AVE5	X800 GT42	4	2,97	4,63	4,1	44,0	0,43	0,1	0,5	-
M7,0	1,0	1,0	12,0	5,0	MA4.MT10.01.12.05 AM	AQ0N	X800 GT42	4	3,51	5,92	4,9	44,0	0,54	0,13	0,6	-
M7,0	1,0	1,0	15,0	5,0	MA4.MT10.01.15.05 AM	AQ0P	X800 GT42	4	3,5	5,92	4,9	44,0	0,54	0,13	0,6	-
▼ ØDh6 = 6,0 mm																
M7,0	0,5	1,5	15,0	6,0	MA3.MT15.01.15.06 AM	AAF4	X800 GT42	3	3,5	6,0	5,8	58,0	0,92	0,06	0,8	-
▼ ØDh6 = 6,35 mm																
M7,0	0,5	1,5	15,0	6,35	MA3.MT15.01.15.250 AM	AS4P	X800 GT42	3	3,5	6,0	5,8	58,0	0,92	0,06	0,8	-
▼ ØDh6 = 7,92 mm																
M9,0	0,5	1,5	25,0	7,92	MA3.MT15.01.25.312 AM	AS4K	X800 GT42	3	5,5	8,0	7,8	68,0	0,92	0,06	1,0	-
M10,0	1,0	2,0	25,0	7,92	MA3.MT20.01.25.312 AM	AS4M	X800 GT42	3	5,0	8,0	7,8	68,0	1,19	0,12	1,0	-
▼ ØDh6 = 8,0 mm																
M9,0	0,5	1,5	25,0	8,0	MA3.MT15.01.25.08 AM	AAVN	X800 GT42	3	5,5	8,0	7,8	68,0	0,91	0,06	1,0	-
M10,0	1,0	2,0	25,0	8,0	MA3.MT20.01.25.08 AM	AFM6	X800 GT42	3	5,0	8,0	7,8	68,0	1,19	0,12	1,0	-

Bestellbeispiel // Order example: MA3.MT20.01.25.08 AM X800 (X800 = Schneidstoff // Grade)

Bitte beachten Sie die zusätzlichen Hinweise zu den Mehrbereichswerkzeugen im Infobereich rechts oben.
Please read the additional notes mentioned in the information area on the top right corner of this page.

Die angegebene Gewindegrößeneignung bezieht sich auf die Startsteigung.
The mentioned thread size „As of thread size“ is based on the starting pitch.

Mehr Infos zu den **Mehrbereichswerkzeugen** und deren **Gewindegrößeneignung** finden Sie auf Seite 649
More information about the **multi-purpose thread milling tools** and the **thread size suitability** can be found on page 649

Metrisches ISO-Regelgewinde, Teilprofil

Gewindefräsen ab Bohrungsdurchmesser 1,5 mm, metrisches ISO-Regelgewinde, Teilprofil. Aufnahme nach DIN 6535 HA.

Metric ISO-Coarse thread, partial profile

Thread milling as of bore diameter 1,5 mm, metric ISO coarse thread, partial profile. Shank according to DIN 6535 HA.

Schnittwerte (Start) // Cutting parameters (Start)		
fzm	hmax	Vc
0,02 mm	0,03 mm	Seite/Page 638

Bitte Hinweise im Anhang beachten // Please read add. notes
ALL (Seite/Page 645), H04 (Seite/Page 648), H07 (Seite/Page 648)

SP Legende
Legend

HM Legende
Legend

Scan
QR-Code

650

Oder besuchen Sie // Or Visit
www.simtek.info/cp/1099

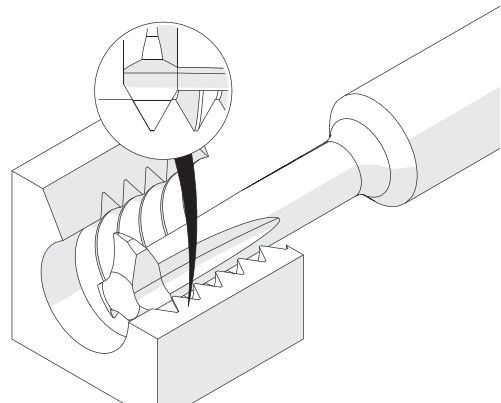
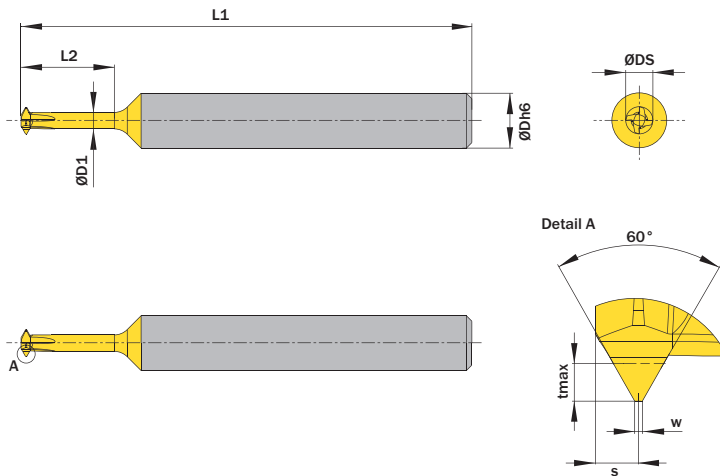


Illustration zeigt beispielhafte Anwendungsmöglichkeit mit ähnlichem Werkzeug.
Image shows exemplary application possibility with similar tool.

Abbildung zeigt / Drawing shows: MA4.MT04.C.01.05.03 AM

Ab Gewindegröße As of thread size	Steigung (vom) Pitch (as of)	Steigung (bis) Pitch (up to)	L2	ØDh6	Artikelnummer Part number	Webcode www.simtek.com/webcode	Unsere erste Wahl Our first choice	ZEFP	ØD1	ØDmin (Min. Bohrung) ØDmin (min. bore)	ØDS	L1	tmax	w	S	Connectcode www.simtek.com/ccode
▼ ØDh6 = 3,0 mm																
M2	0,4	0,45	5,1	3,0	MA4.MT04.C.01.05.03 AM	AX06	X800 G742	4	0,77	1,5	1,45	32,0	0,27	0,05	0,3	-
M2,5	0,45	0,5	6,1	3,0	MA4.MT04.C.01.06.03 AM	AX07	X800 G742	4	1,06	1,9	1,8	32,0	0,29	0,05	0,3	-
M3	0,5	0,6	7,1	3,0	MA4.MT05.C.01.07.03 AM	AX08	X800 G742	4	1,27	2,3	2,15	32,0	0,35	0,06	0,3	-
M3,5	0,6	0,7	8,1	3,0	MA4.MT06.C.01.08.03 AM	AX09	X800 G742	4	1,39	2,7	2,4	32,0	0,41	0,07	0,4	-
▼ ØDh6 = 5,0 mm																
M4	0,7	0,8	9,1	5,0	MA4.MT07.C.01.09.05 AM	AX1A	X800 G742	4	1,58	3,1	2,7	44,0	0,46	0,08	0,4	-
M5	0,8	1,0	10,1	5,0	MA4.MT08.C.01.10.05 AM	AX1B	X800 G742	4	2,14	3,9	3,57	44,0	0,59	0,1	0,5	-
M6	1,0	1,25	12,2	5,0	MA4.MT10.C.01.12.05 AM	AX1C	X800 G742	4	2,44	4,6	4,2	44,0	0,74	0,12	0,6	-
M7	1,0	1,25	15,2	5,0	MA4.MT10.C.01.15.05 AM	AX1D	X800 G742	4	3,09	5,6	4,9	44,0	0,74	0,12	0,6	-

Bestellbeispiel // Order example: **MA4.MT10.C.01.12.05 AM X800** (X800 = Schneidstoff // Grade)

Die angegebene Gewindegrößeneignung bezieht sich auf die Startsteigung.
The mentioned thread size „As of thread size“ is based on the starting pitch.

Bitte beachten Sie die zusätzlichen Hinweise zu den Mehrbereichswerkzeugen im Infobereich rechts oben.
Please read the additional notes mentioned in the information area on the top right corner of this page.

Mehr Infos zu den **Mehrbereichswerkzeugen** und deren **Gewindegrößeneignung** finden Sie auf Seite 649

More information about the **multi-purpose thread milling tools** and the **thread size suitability** can be found on page 649

Gewindefräsen, UNC/UNF Vollprofil

Zur Herstellung des kompletten Gewindepfils mit erforderlicher Tiefe. Aufnahme nach DIN 6535 HA.

Thread milling, UNC/UNF full profile

For a complete thread profile with correct depth. Shank according to DIN 6535 HA.

Schnittwerte (Start) // Cutting parameters (Start)		
f _{zm} 0,02 mm	h _{max} 0,03 mm	V _c Seite/Page 638

Bitte Hinweise im Anhang beachten // Please read add. notes
ALL (Seite/Page 645), H07 (Seite/Page 648)



SP Legende
HM Legend
650

Scan QR-Code Oder besuchen Sie // Or Visit
www.simtek.info/cp/1247

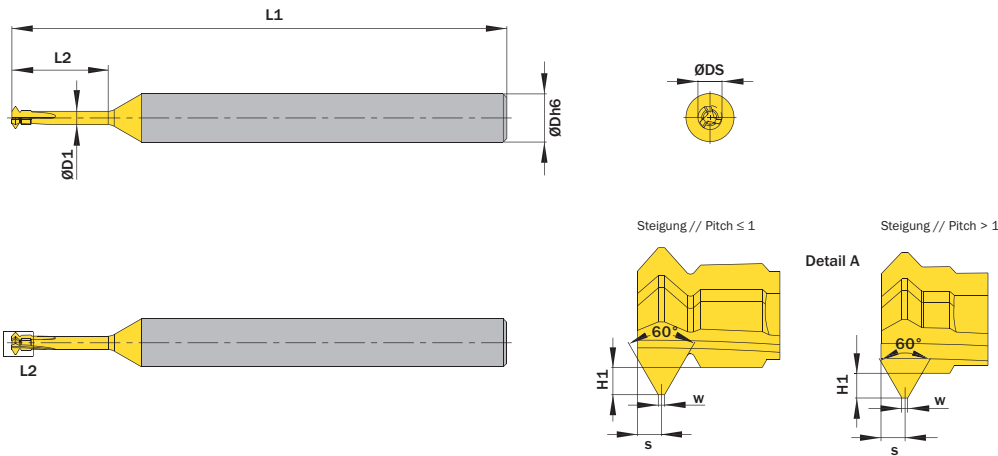


Abbildung zeigt / Drawing shows: MA3.UN40.C.02.08.04 AM

Gang/Zoll Threads/inch	L2	ØDh6	Artikelnummer Part number	Webcode www.simtek.com/webcode	Unsere erste Wahl Our first choice	ZEFP	Regelgewinde Standard pitch thread	ØD1	ØDmin (Min. Bohrung) ØDmin (min. bore)	ØDS	H1	L1	Steigung (von) Pitch (as of)	S	w	Connectcode www.simtek.com/ccode
▼ ØDh6 = 4,0 mm																
32	8,0	4,0	MA3.UN32.C.02.08.04 AM	AZ2T	X800 G142	3	Ja / Yes	1,14	2,6	2,2	0,43	44,0	0,794	0,4	0,1	-
40	8,0	4,0	MA3.UN40.C.02.08.04 AM	AZ2U	X800 G142	3	Nein / No	1,41	2,8	2,3	0,344	44,0	0,635	0,3	0,08	-
40	8,0	4,0	MA3.UN40.C.02.08.04 AM	AZ2Q	X800 G142	3	Ja / Yes	1,11	2,4	2,0	0,344	44,0	0,635	0,3	0,08	-
44	8,0	4,0	MA3.UN44.C.02.08.04 AM	AZ2S	X800 G142	3	Nein / No	1,18	2,5	2,0	0,312	44,0	0,577	0,3	0,07	-
▼ ØDh6 = 6,0 mm																
24	10,0	6,0	MA3.UN24.C.02.10.06 AM	AZ2W	X800 G142	3	Ja / Yes	1,55	3,6	2,9	0,573	58,0	1,058	0,4	0,13	-
36	10,0	6,0	MA3.UN36.C.02.10.06 AM	AZ2V	X800 G142	3	Nein / No	1,53	3,4	2,5	0,382	58,0	0,706	0,3	0,09	-
16	25,0	6,0	MA4.UN16.C.02.25.06 AM	AZ2Ø	X800 G142	4	Ja / Yes	3,5	7,8	5,5	0,86	78,0	1,588	0,7	0,2	-
18	10,0	6,0	MA4.UN18.C.02.10.06 AM	AZ2Z	X800 G142	4	Ja / Yes	2,47	6,4	4,2	0,764	68,0	1,411	0,6	0,18	-
20	10,0	6,0	MA4.UN20.C.02.10.06 AM	AZ2X	X800 G142	4	Ja / Yes	1,93	10,0	3,5	0,687	68,0	1,27	0,6	0,16	-
28	10,0	6,0	MA4.UN28.C.02.10.06 AM	AZ2Y	X800 G142	4	Nein / No	2,32	5,3	3,5	0,491	68,0	0,907	0,4	0,11	-
▼ ØDh6 = 8,0 mm																
14	25,0	8,0	MA4.UN14.C.02.25.08 AM	AZ21	X800 G142	4	Ja / Yes	4,5	9,1	6,8	0,982	78,0	1,814	0,8	0,23	-
20	30,0	8,0	MA4.UN20.C.02.30.08 AM	AZ22	X800 G142	4	Nein / No	5,5	9,1	7,2	0,687	78,0	1,27	0,6	0,16	-

Bestellbeispiel // Order example: **MA4.UN28.02.10.06 AM X800** (X800 = Schneidstoff // Grade)

Metrisches ISO-Gewindefräsen, Vollprofil

Gewindefräsen ab Bohrungsdurchmesser 2,4 mm, metrisches ISO-Gewinde, Vollprofil. Aufnahme nach DIN 6535 HA.

Thread milling, metric ISO-Thread, full profile

Thread milling as of bore diameter 2,4 mm, ISO metric thread, full profile. Shank according to DIN 6535 HA.

Schnittwerte (Start) // Cutting parameters (Start)		
fzm	hmax	Vc
0,02 mm	0,03 mm	Seite/Page 638

Bitte Hinweise im Anhang beachten // Please read add. notes
ALL (Seite/Page 645), H06 (Seite/Page 648), H07 (Seite/Page 648)

SP

Legende

HM

Legend

650

Scan QR-Code

Oder besuchen Sie // Or Visit www.simtek.info/cp/1246

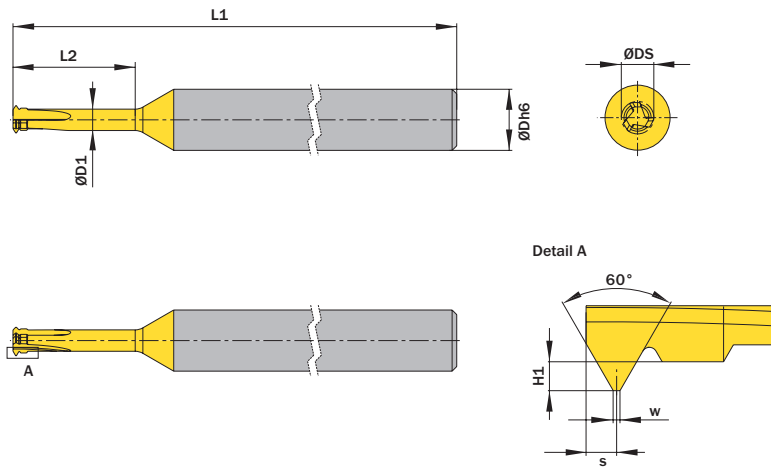


Abbildung zeigt / Drawing shows: MA3.MT03.02.08.04 AM

Ab Gewindegröße As of thread size	Ab Gewindedurchmesser // As of nominal thread diameter	L2	ØDh6	Artikelnummer Part number	Webcode www.simtek.com/webcode	Unsere erste Wahl Our first choice				Regelgewinde Standard pitch thread	ØD1	ØDmin (Min. Bohrung) ØDmin (min. bore)	ØDS	H1	L1	Steigung (von) Pitch (as of)	S	w	Connectcode www.simtek.com/code
						P	M	K	N										
▼ ØDh6 = 4,0 mm																			
M2,5	2,26	8,0	4,0	MA3.MT03.02.08.04 AM	AZ2H	X800	GT42	3	Nein / No	1,4	2,4	2,0	0,19	44,0	0,35	0,2	0,04	-	upd
M2,5	2,47	8,0	4,0	MA3.MT05.C.02.08.04 AM	AZ2J	X800	GT42	3	Ja / Yes	1,25	2,4	2,0	0,27	44,0	0,5	0,3	0,06	-	upd
M3	2,94	9,0	4,0	MA3.MT06.C.02.09.04 AM	AZ2K	X800	GT42	3	Ja / Yes	1,4	2,7	2,3	0,33	44,0	0,6	0,3	0,08	-	upd
▼ ØDh6 = 6,0 mm																			
M3,5	3,29	10,0	6,0	MA3.MT05.02.10.06 AM	AZ2M	X800	GT42	3	Nein / No	2,0	3,3	2,8	0,27	58,0	0,5	0,3	0,06	-	upd
M4	3,65	10,0	6,0	MA3.MT07.C.02.10.06 AM	AZ2N	X800	GT42	3	Ja / Yes	1,85	3,3	2,8	0,38	58,0	0,7	0,4	0,09	-	upd
M6	5,21	16,0	6,0	MA4.MT07.02.16.06 AM	AZ3H	X800	GT42	4	Nein / No	3,1	5,0	4,2	0,41	68,0	0,75	0,5	0,09	-	upd
M5	4,67	12,0	6,0	MA4.MT08.C.02.12.06 AM	A5N1	X800	GT42	4	Ja / Yes	2,4	4,1	3,6	0,43	58,0	0,8	0,6	0,09	-	new
M8	7,2	16,0	6,0	MA4.MT10.02.16.06 AM	AZ3M	X800	GT42	4	Nein / No	4,0	6,5	5,5	0,54	68,0	1,0	0,6	0,12	-	upd
M6	5,81	16,0	6,0	MA4.MT10.C.02.16.06 AM	AZ3J	X800	GT42	4	Ja / Yes	2,8	5,0	4,2	0,54	68,0	1,0	0,6	0,12	-	upd
M8	7,91	16,0	6,0	MA4.MT12.C.02.16.06 AM	AZ3N	X800	GT42	4	Ja / Yes	3,7	6,5	5,5	0,68	68,0	1,25	0,8	0,16	-	upd
▼ ØDh6 = 8,0 mm																			
M8	7,88	20,0	8,0	MA4.MT07.02.20.08 AM	AZ3P	X800	GT42	4	Nein / No	5,6	8,0	6,8	0,41	68,0	0,75	0,5	0,09	-	upd
M10	8,59	25,0	8,0	MA4.MT10.02.25.08 AM	AZ3Q	X800	GT42	4	Nein / No	5,4	8,0	6,8	0,54	78,0	1,0	0,6	0,12	-	upd
M12	10,13	20,0	8,0	MA4.MT15.C.02.20.08 AM	AZ3S	X800	GT42	4	Ja / Yes	4,7	8,0	6,8	0,81	68,0	1,5	0,9	0,19	-	upd
▼ ØDh6 = 10,0 mm																			
M10	9,81	20,0	10,0	MA4.MT10.02.20.10 AM	AZ3T	X800	GT42	4	Nein / No	6,3	10,0	8,0	0,54	68,0	1,0	0,6	0,12	-	upd
M12	10,61	30,0	10,0	MA4.MT12.02.30.10 AM	AZ3U	X800	GT42	4	Nein / No	6,1	10,0	8,0	0,68	78,0	1,25	0,8	0,16	-	upd
M14	12,37	30,0	10,0	MA4.MT17.C.02.30.10 AM	AZ3V	X800	GT42	4	Ja / Yes	5,5	10,0	8,0	0,95	78,0	1,75	1,0	0,22	-	upd

Bestellbeispiel // Order example: MA4.MT12.C.02.16.06 AM X800 (X800 = Schneidstoff // Grade)

Gewindefräsen, BSW/BSF Vollprofil

Zur Herstellung des vollständigen Gewindepfils mit erforderlicher Tiefe sowie Kopf- und Fußradien. Aufnahme nach DIN 6535 HA.

Thread milling, BSW/BSF Full Profile

For a complete thread profile with correct depth, top radius and bottom radius. Shank according to DIN 6535 HA.

Schnittwerte (Start) // Cutting parameters (Start)		
fzm	hmax	Vc
0,02 mm	0,03 mm	Seite/Page 638

Bitte Hinweise im Anhang beachten // Please read add. notes
ALL (Seite/Page 645), H07 (Seite/Page 648)

SP

HM

Legende Legend

650

Scan QR-Code

Oder besuchen Sie // Or Visit www.simtek.info/cp/1245

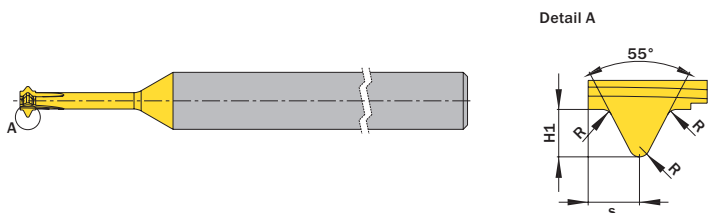
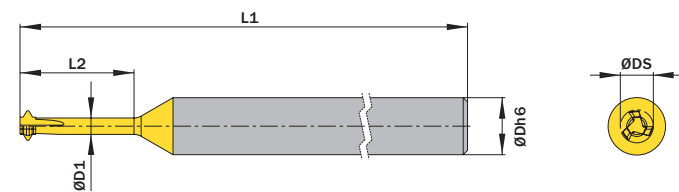


Abbildung zeigt / Drawing shows: MA3.BS32.C.02.08.04 AM

Gang/Zoll Threads/inch	L2 mm	ØDh6 mm	Artikelnummer Part number	Webcode www.simtek.com/webcode	Unsere erste Wahl Our first choice		ZEFP	Regelgewinde Standard pitch thread	ØD1 mm	ØDmin (Min. Bohrung) ØDmin (min. bore)	ØDS mm	H1 mm	L1 mm	Steigung (von) Pitch (as of)	R mm	S mm	Connectcode www.simtek.com/code
					B	MKN											
▼ ØDh6 = 4,0 mm																	
32	8,0	4,0	MA3.BS32.C.02.08.04 AM	AZ3X	X800	GT42	3	Ja / Yes	1,15	2,9	2,3	0,51	44,0	0,794	0,11	0,6	-
40	8,0	4,0	MA3.BS40.C.02.08.04 AM	AZ3W	X800	GT42	3	Ja / Yes	1,1	2,3	2,0	0,41	44,0	0,635	0,09	0,4	-
▼ ØDh6 = 6,0 mm																	
20	16,0	6,0	MA3.BS20.C.02.16.06 AM	AZ31	X800	GT42	3	Ja / Yes	2,1	4,7	4,0	0,81	68,0	1,27	0,17	0,9	-
24	10,0	6,0	MA3.BS24.C.02.10.06 AM	AZ3Y	X800	GT42	3	Ja / Yes	1,25	3,4	2,8	0,68	58,0	1,058	0,15	0,8	-
26	16,0	6,0	MA3.BS26.02.16.06 AM	AZ32	X800	GT42	3	Nein / No	2,65	5,0	4,2	0,63	68,0	0,977	0,13	0,7	-
28	10,0	6,0	MA3.BS28.02.10.06 AM	AZ30	X800	GT42	3	Nein / No	2,2	4,3	3,6	0,58	58,0	0,907	0,13	0,6	-
32	10,0	6,0	MA3.BS32.02.10.06 AM	AZ3Z	X800	GT42	3	Nein / No	1,6	3,7	2,8	0,51	58,0	0,794	0,11	0,6	-
18	16,0	6,0	MA4.BS18.C.02.16.06 AM	AZ24	X800	GT42	4	Ja / Yes	3,0	6,1	5,2	0,9	68,0	1,411	0,19	1,0	-
22	16,0	6,0	MA4.BS22.02.16.06 AM	AZ25	X800	GT42	4	Nein / No	3,4	6,4	5,3	0,74	68,0	1,155	0,16	0,8	-
26	16,0	6,0	MA4.BS26.02.16.06 AM	AZ23	X800	GT42	4	Nein / No	3,5	5,8	5,0	0,63	68,0	0,977	0,13	0,7	-
▼ ØDh6 = 8,0 mm																	
14	25,0	8,0	MA4.BS14.C.02.25.08 AM	AZ29	X800	GT42	4	Ja / Yes	4,3	8,7	7,2	1,16	78,0	1,814	0,25	1,2	-
16	16,0	8,0	MA4.BS16.C.02.16.08 AM	AZ27	X800	GT42	4	Ja / Yes	4,0	7,4	6,3	1,02	68,0	1,588	0,22	1,1	-
18	25,0	8,0	MA4.BS18.02.25.08 AM	AZ3A	X800	GT42	4	Nein / No	5,0	9,3	7,5	0,9	78,0	1,411	0,19	1,0	-
20	16,0	8,0	MA4.BS20.02.16.08 AM	AZ28	X800	GT42	4	Nein / No	4,6	7,8	6,5	0,81	68,0	1,27	0,17	0,9	-
▼ ØDh6 = 10,0 mm																	
12	30,0	10,0	MA4.BS12.C.02.30.10 AM	AZ3B	X800	GT42	4	Ja / Yes	5,4	9,9	8,5	1,36	78,0	2,117	0,29	1,4	-
16	30,0	10,0	MA4.BS16.02.30.10 AM	AZ3C	X800	GT42	4	Nein / No	7,0	10,6	9,5	1,02	78,0	1,588	0,22	1,2	-

Bestellbeispiel // Order example: **MA3.BS28.02.10.06 AM X800** (X800 = Schneidstoff // Grade)

Gewindefräsen, Whitworth Rohrgewinde BSP

Zur Herstellung des vollständigen Gewindeprofils mit erforderlicher Tiefe sowie Kopf- und Fußradien. Aufnahme nach DIN 6535 HA.

Thread milling, Whitworth Pipe Thread BSP

For a complete thread profile with correct depth, top radius and bottom radius. Shank according to DIN 6535 HA.

Schnittwerte (Start) // Cutting parameters (Start)		
fzm 0,02 mm	hmax 0,03 mm	Vc Seite/Page 638

Bitte Hinweise im Anhang beachten // Please read add. notes
ALL (Seite/Page 645), H07 (Seite/Page 648)

SP

Legende

HM

Legend

650

Scan QR-Code

Oder besuchen Sie // Or Visit www.simtek.info/cp/1248

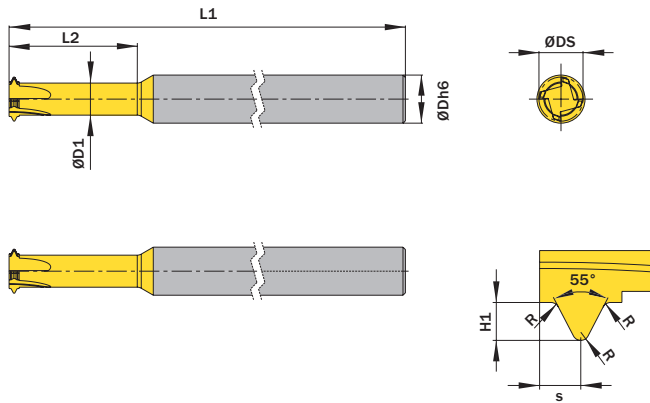


Abbildung zeigt / Drawing shows: MA4.BS28.P.02.16.06 AM

Gewinde Thread	Gang/Zoll Threads/Inch	L2 mm	ØDh6 mm	Artikelnummer Part number	Webcode www.simtek.com/webcode	Unsere erste Wahl Our first choice				ZEFP	ØD1 mm	ØDmin (Min. Bohrung) ØDmin (min. bore)	ØDS mm	H1 mm	L1 mm	Steigung (von) Pitch (as of)	R mm	S mm	Connectcode www.simtek.com/code
						P	M	K	N										
▼ ØDh6 = 6,0 mm																			
G 1/16"	28	16,0	6,0	MA4.BS28.P.02.16.06 AM	AZ3D	X800	GT42	4	4,0	6,5	5,5	0,58	68,0	0,91	0,13	0,6	-		
▼ ØDh6 = 8,0 mm																			
G 1/8"	28	16,0	8,0	MA4.BS28.P.02.16.08 AM	AZ3E	X800	GT42	4	5,0	8,5	6,6	0,58	68,0	0,91	0,13	0,6	-		
▼ ØDh6 = 10,0 mm																			
G 1/4"	19	20,0	10,0	MA4.BS19.P.02.20.10 AM	AZ3F	X800	GT42	4	7,0	11,4	9,5	0,86	68,0	1,34	0,18	0,9	-		
▼ ØDh6 = 12,0 mm																			
G 3/8"	19	30,0	12,0	MA4.BS19.P.02.30.12 AM	AZ3G	X800	GT42	4	9,3	14,9	11,8	0,86	78,0	1,34	0,18	0,9	-		

Bestellbeispiel // Order example: **MA4.BS28.P.02.16.08 AM X800** (X800 = Schneidstoff // Grade)

Fräsen von Fasen

Fasenfräsen beidseitig. Geeignet ab Bohrungsdurchmesser 6,0 mm. Aufnahme nach DIN 6535 HA.

Chamfering

Chamfering on both sides. For use in bores as of minimum bore diameter 6,0 mm. Shank according to DIN 6535 HA.

Schnittwerte (Start) // Cutting parameters (Start)		
f _{zm} 0,02 mm	h _{max} 0,03 mm	V _c Seite/Page 638

Bitte Hinweise im Anhang beachten // Please read add. notes
ALL (Seite/Page 645), H07 (Seite/Page 648)



SP Legende
HM Legend
650

Scan QR-Code Oder besuchen Sie // Or Visit
www.simtek.info/cp/293

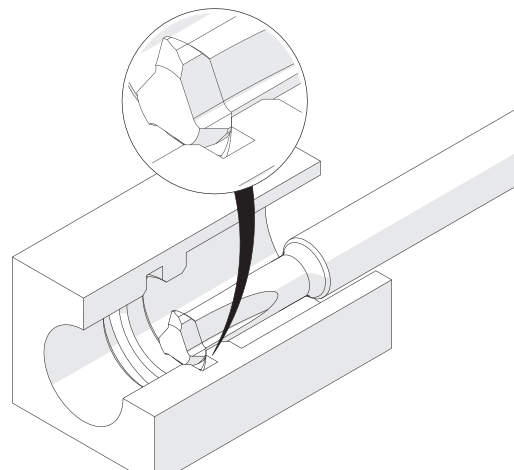
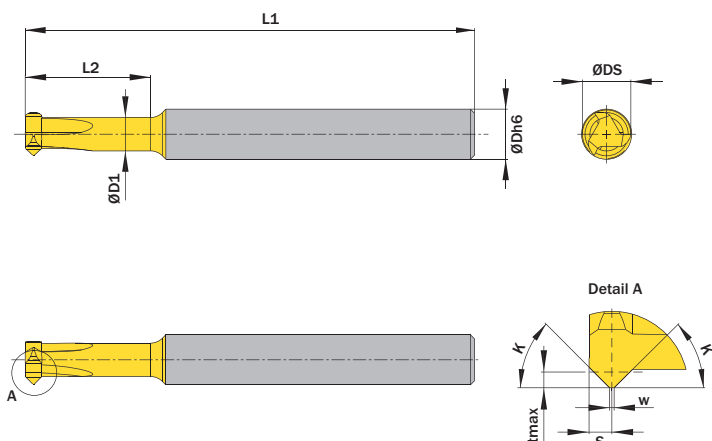


Illustration zeigt beispielhafte Anwendungsmöglichkeit mit ähnlichem Werkzeug.
Image shows exemplary application possibility with similar tool.

Abbildung zeigt / Drawing shows: MA3.4545.02.15.06 AF

K	w	L2	ØDmin (Min. Bohrung) ØDmin (min. bore)	Artikelnummer Part number	Webcode www.simtek.com/webcode	Unsere erste Wahl Our first choice		ZEFP	ØD1	ØDh6	ØDS	L1	S	tmax	Connectcode www.simtek.com/code
						B	M								
▼ ØDmin (Min. Bohrung) // ØDmin (min. bore) = 6,0 mm															
45°	0,2	15,0	6,0	MA3.4545.02.15.06 AF	AHTP	X800	G742	3	4,2	6,0	5,8	58,0	1,0	0,6	-
45°	0,2	15,0	6,0	MA3.4545.02.15.250 AF	AS4Q	X800	G742	3	4,2	6,35	5,8	58,0	1,0	0,6	-
45°	0,2	25,0	6,0	MA3.4545.02.25.06 AF	AC3U	X800	G742	3	4,2	6,0	5,8	68,0	1,0	0,6	-
45°	0,2	25,0	6,0	MA3.4545.02.25.250 AF	AS4H	X800	G742	3	4,2	6,35	5,8	68,0	1,0	0,6	-
▼ ØDmin (Min. Bohrung) // ØDmin (min. bore) = 8,0 mm															
45°	0,2	25,0	8,0	MA3.4545.02.25.08 AF	AKDE	X800	G742	3	5,0	8,0	7,8	68,0	1,5	1,2	-
45°	0,2	25,0	8,0	MA3.4545.02.25.312 AF	AS4J	X800	G742	3	5,0	7,92	7,8	68,0	1,5	1,2	-
45°	0,2	35,0	8,0	MA3.4545.02.35.08 AF	AKCW	X800	G742	3	5,0	8,0	7,8	78,0	1,5	1,2	-
45°	0,2	35,0	8,0	MA3.4545.02.35.312 AF	AS4N	X800	G742	3	5,0	7,92	7,8	78,0	1,5	1,2	-

Bestellbeispiel // Order example: **MA3.4545.02.15.06 AF X800** (X800 = Schneidstoff // Grade)

Fräsen von Scheibenfedernuten

Fräsen von Scheibenfedernuten (DIN6888).
Aufnahme nach DIN 6535 HA und DIN 1835 A.

Keyway milling

Keyway milling according to DIN6888.
Shank according to DIN 6535 HA and DIN 1835 A.

Schnittwerte (Start) // Cutting parameters (Start)		
fzm	hmax	Vc
0,02 mm	0,03 mm	Seite/Page 638

Bitte Hinweise im Anhang beachten // Please read add. notes
ALL (Seite/Page 645), H07 (Seite/Page 648)



SP Legende
HM Legend

650

Scan QR-Code

Oder besuchen Sie // Or Visit
www.simtek.info/cp/304

Weldon-Aufnahme auf Anfrage erhältlich.
Weldon fixation available upon request.

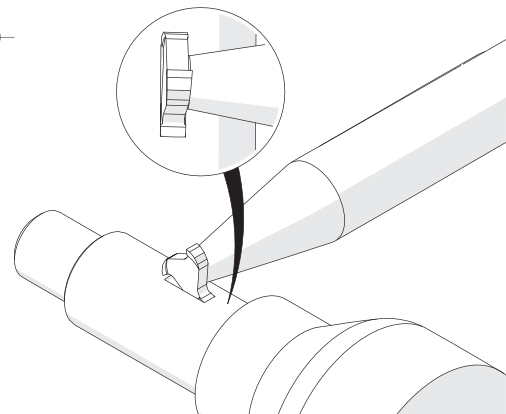
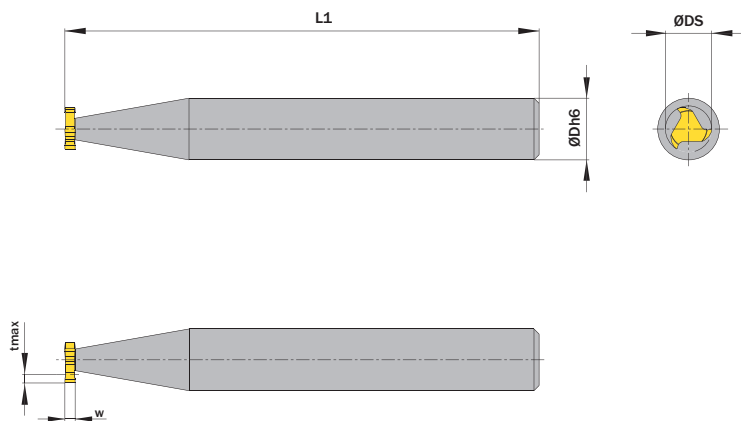


Illustration zeigt beispielhafte Anwendungsmöglichkeit mit ähnlichem Werkzeug.
Image shows exemplary application possibility with similar tool.

Abbildung zeigt / Drawing shows: MA3.100.09.06.00 AS

w e8	ØDS	ØDh6	Artikelnummer Part number	Webcode www.simtek.com/webcode	Unsere erste Wahl Our first choice	ZEFP	L1	tmax	Aufnahme nach Shank according to	Connectcode www.simtek.com/code
mm	mm	mm			P M K N S		mm	mm		
▼ ØDS = 4,5 mm										
1,0	4,5	6,0	MA3.100.04.06.00 AS	AKØY	X800 GT42	3	50,0	1,0	DIN 6535 HA	-
▼ ØDS = 7,5 mm										
1,5	7,5	8,0	MA3.150.07.08.00 AS	ANPA	X800 GT42	3	50,0	2,0	DIN 6535 HA	-
2,0	7,5	8,0	MA3.200.07.08.00 AS	AK6Z	X800 GT42	3	50,0	1,8	DIN 6535 HA	-
▼ ØDS = 10,5 mm										
2,0	10,5	12,0	MA3.200.10.12.00 AS	AEH6	X800 GT42	3	60,0	2,9	DIN 6535 HA	-
2,5	10,5	12,0	MA3.250.10.12.00 AS	ACMK	X800 GT42	3	60,0	2,9	DIN 6535 HA	-
3,0	10,5	12,0	MA3.300.10.12.00 AS	AM42	X800 GT42	3	60,0	2,5	DIN 6535 HA	-
▼ ØDS = 13,5 mm										
3,0	13,5	16,0	MA3.300.13.16.00 AS	AF2J	X800 GT42	3	70,0	3,8	DIN 1835 A	-
4,0	13,5	16,0	MA3.400.13.16.00 AS	AEØ1	X800 GT42	3	70,0	3,5	DIN 1835 A	-
▼ ØDS = 16,5 mm										
3,0	16,5	16,0	MA3.300.16.16.00 AS	ADT5	X800 GT42	3	70,0	5,3	DIN 1835 A	-
4,0	16,5	16,0	MA3.400.16.16.00 AS	AJXW	X800 GT42	3	70,0	5,0	DIN 1835 A	-
5,0	16,5	16,0	MA3.500.16.16.00 AS	AGA J	X800 GT42	3	70,0	4,5	DIN 1835 A	-
▼ ØDS = 19,5 mm										
4,0	19,5	16,0	MA3.400.19.16.00 AS	ANKE	X800 GT42	3	70,0	6,0	DIN 1835 A	-
5,0	19,5	16,0	MA3.500.19.16.00 AS	AMØX	X800 GT42	3	70,0	5,5	DIN 1835 A	-
6,0	19,5	16,0	MA3.600.19.16.00 AS	AB59	X800 GT42	3	70,0	5,1	DIN 1835 A	-
▼ ØDS = 22,5 mm										
5,0	22,5	16,0	MA3.500.22.16.00 AS	ANVG	X800 GT42	3	70,0	7,0	DIN 1835 A	-
6,0	22,5	16,0	MA3.600.22.16.00 AS	AHC5	X800 GT42	3	70,0	6,6	DIN 1835 A	-
8,0	22,5	16,0	MA3.800.22.16.00 AS	ADG7	X800 GT42	3	70,0	6,2	DIN 1835 A	-
▼ ØDS = 25,5 mm										
6,0	25,5	16,0	MA3.600.25.16.00 AS	AH8A	X800 GT42	3	70,0	7,6	DIN 1835 A	-

Bestellbeispiel // Order example: MA3.150.07.08.00 AS X800 (X800 = Schneidstoff // Grade)

Info

Die Werkzeugsysteme simmill PMX / PX / SX / UX / VX
 The tool systems simmill PMX / PX / SX / UX / VX



simmill VX
 SIMTEK milling tools type VX

simmill UX
 SIMTEK milling tools type UX

simmill SX
 SIMTEK milling tools type SX

simmill PX
 SIMTEK milling tools type PX

simmill PMX
 SIMTEK milling tools type PMX

Neu/New

Für Bohrungsdurchmesser (mm) // For bore diameter (mm)

...	2	3	4	5	6	7	8	9	10	11	12	13	14	15	16	17	18	19	20	21	22	23	24	25	26	27	28	29	30	31	32	33	34	35	36	37	38	39	40	41	42	43	44	...
-----	---	---	---	---	---	---	---	---	----	----	----	----	----	----	----	----	----	----	----	----	----	----	----	----	----	----	----	----	----	----	----	----	----	----	----	----	----	----	----	----	----	----	----	-----

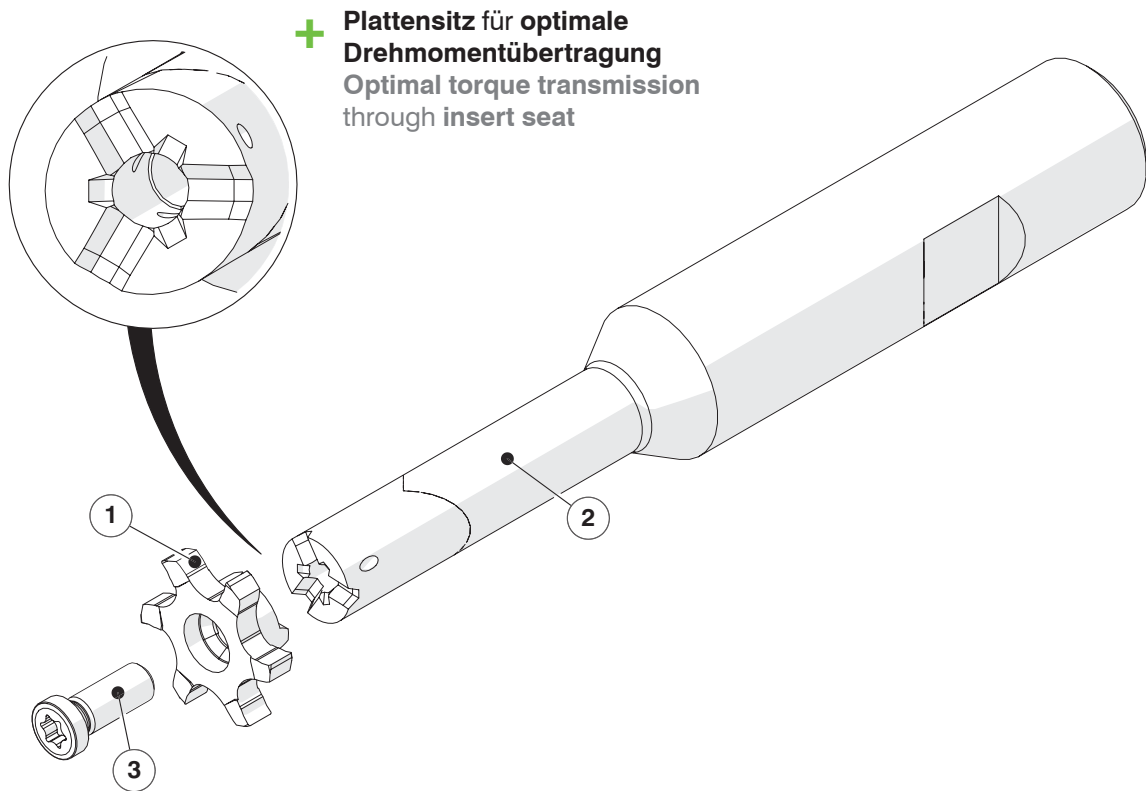
simmill PMX
 SIMTEK milling tools type PMX

simmill PX
 SIMTEK milling tools type PX

simmill SX
 SIMTEK milling tools type SX

simmill UX
 SIMTEK milling tools type UX

simmill VX
 SIMTEK milling tools type VX



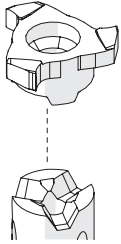
- ① **Wechselbare Hochleistungs-Frässchneidplatten** aus Feinstkorn-Hartmetall mit einer umfangreichen Auswahl an **Beschichtungen für höchste Anforderungen**
High performance micro grain carbide milling inserts available with a wide range of **coatings for every application**
- ② **Frälerschäfte** aus **Hartmetall** oder **Stahl**, überwiegend mit **innerer Kühlmittelzufuhr** und **schwingungsdämpfenden Plattensitz**.
Milling cutter shanks made of **carbide** or **steel**, mainly with **through coolant supply** and **vibration-reducing insert seat**
- ③ **Torx-Schraube**
Torx screw

Info

Das Werkzeugsystem simmill PMX The Tool System simmill PMX

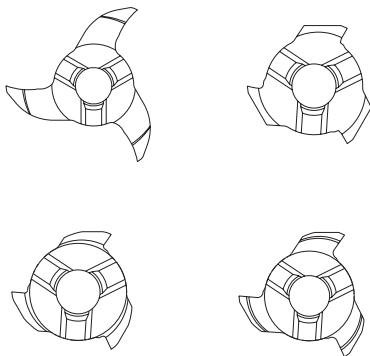
simmill PMX
SIMTEK milling tools type PMX

- + System bestehend aus Fräserschaft und wechselbarer Hartmetall-Frässchneidplatte
System of milling cutter shank and indexable carbide milling insert



- + Für Bohrungen zwischen \varnothing 7,0 und \varnothing 11,0 mm
For bores between \varnothing 7,0 and \varnothing 11,0 mm

- + Dreischneidige Schneidplatten in den Größen \varnothing 7,0 mm (PM7), \varnothing 8,0 mm (PM8) und \varnothing 9,0 mm – 11,0 mm (PM9) auf einem Fräserschaft einsetzbar
Three edged milling inserts in sizes \varnothing 7,0 mm (PM7), \varnothing 8,0 mm (PM8) and \varnothing 9,0 mm – 11,0 mm (PM9)



- + Weit verbreitetes System
Wide-spread tool system



Ab Seite // As of page

461

Anwendungsübersicht
Application overview

477

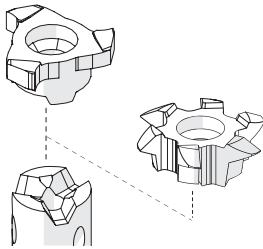
Alle Werkzeuge
All tools

Info

Das Werkzeugsystem simmill PX The Tool System simmill PX

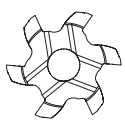
simmillPX
SIMTEK milling tools type PX

- + System bestehend aus Fräserschaft und wechselbarer Hartmetall-Frässchneidplatte
System of milling cutter shank and indexable carbide milling insert

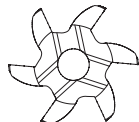


- + Für Bohrungen zwischen $\varnothing 10,0$ und $\varnothing 15,0$ mm
For bores between $\varnothing 10,0$ and $\varnothing 15,0$ mm

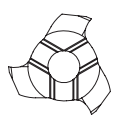
- + Drei- und sechsschneidige Schneidplatten in den Größen $\varnothing 10,0$ mm (P06 und P10) und $\varnothing 12,0$ mm (P12) auf einem Fräserschaft einsetzbar
Three and six edged milling inserts in sizes $\varnothing 10,0$ mm (P06 and P10) and $\varnothing 12,0$ mm (P12) usable on one milling cutter shank



P06...10



P06...12



P10



P12

- + Weit verbreitetes System
Wide-spread tool system



Ab Seite // As of page

461

Anwendungsübersicht
Application overview

484

Alle Werkzeuge
All tools

simmill AX

simmill PMX

simmill PX

simmill SX

simmill UX

simmill VX

simmill H2

simmill K2

simmill MX

simmill OS

Index

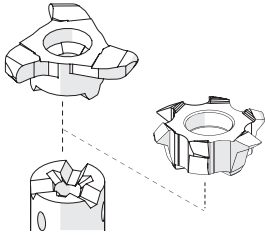
457

Info

Das Werkzeugsystem simmill SX The Tool System simmill SX

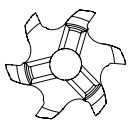
simmill SX
SIMTEK milling tools type SX

- + System bestehend aus Fräserschaft und wechselbarer Hartmetall-Frässchneidplatte
System of milling cutter shank and indexable carbide milling insert

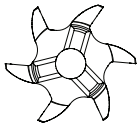


- + Für Bohrungen zwischen $\varnothing 14,0$ und $\varnothing 19,0$ mm
For bores between $\varnothing 14,0$ and $\varnothing 19,0$ mm

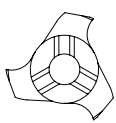
- + Drei- und sechsschneidige Schneidplatten in den Größen $\varnothing 14,0$ (S06), $\varnothing 14,0$ (S14) und $\varnothing 16,0$ (S16) mm auf einem Fräserschaft einsetzbar
Three and six edged milling inserts in sizes $\varnothing 14,0$ (S06), $\varnothing 14,0$ (S14) and $\varnothing 16,0$ (S16) mm usable on one milling cutter shank



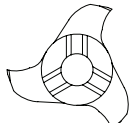
S06...14



S06...16



S14



S16

- + Weit verbreitetes System
Wide-spread tool system



Ab Seite // As of page

461

Anwendungsübersicht
Application overview

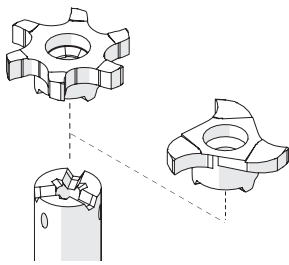
507

Alle Werkzeuge
All tools

Info

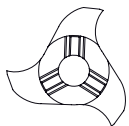
Das Werkzeugsystem simmill UX The Tool System simmill UX

- + System bestehend aus Fräserschaft und wechselbarer Hartmetall-Frässchneidplatte
System of milling cutter shank and indexable carbide milling insert

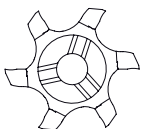


- + Für Bohrungen zwischen \varnothing 18,0 und \varnothing 23,0 mm
For bores between \varnothing 18,0 and \varnothing 23,0 mm

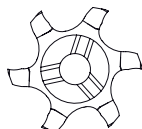
- + Drei- und sechsschneidige Schneidplatten in den Größen \varnothing 18,0 und \varnothing 20,0 mm auf einem Fräserschaft einsetzbar
Three and six edged milling inserts in sizes \varnothing 18,0 and \varnothing 20,0 mm usable on one milling cutter shank



U18 / U20



U06...18



U06...20

- + Weit verbreitetes System
Wide-spread tool system

simmillUX
SIMTEK milling tools type UX



Ab Seite // As of page

461

Anwendungsübersicht
Application overview

528

Alle Werkzeuge
All tools

simmill AX

simmill PMX

simmill PX

simmill SX

simmill UX

simmill VX

simmill H2

simmill K2

simmill MX

simmill OS

Index

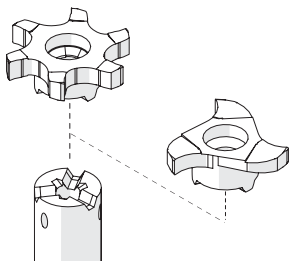
459

Info

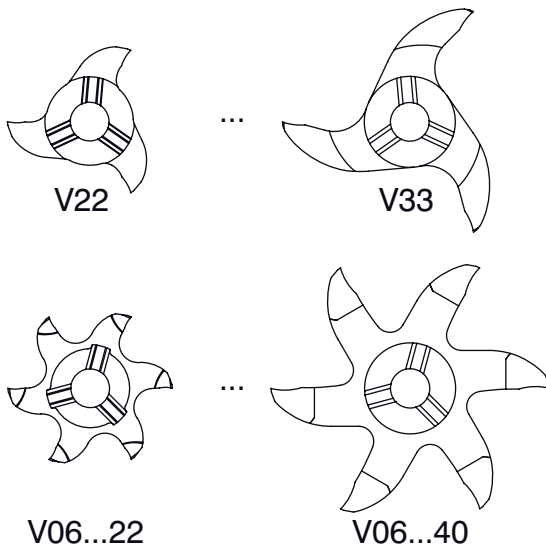
Das Werkzeugsystem simmill VX The Tool System simmill VX

simmill VX
SIMTEK milling tools type VX

- + System bestehend aus Fräserschaft und wechselbarer Hartmetall-Frässchneidplatte
System of milling cutter shank and indexable carbide milling insert



- + Für Bohrungen zwischen $\varnothing 22,0$ und $\varnothing 40,0$ mm
For bores between $\varnothing 22,0$ and $\varnothing 40,0$ mm
- + Drei- und sechsschneidige Schneidplatten in versch. Größen zwischen $\varnothing 22,0$ und $\varnothing 40,0$ mm
Three and six edged milling inserts in different sizes between $\varnothing 22,0$ and $\varnothing 40,0$ mm



- + Weit verbreitetes System
Wide-spread tool system



Ab Seite // As of page

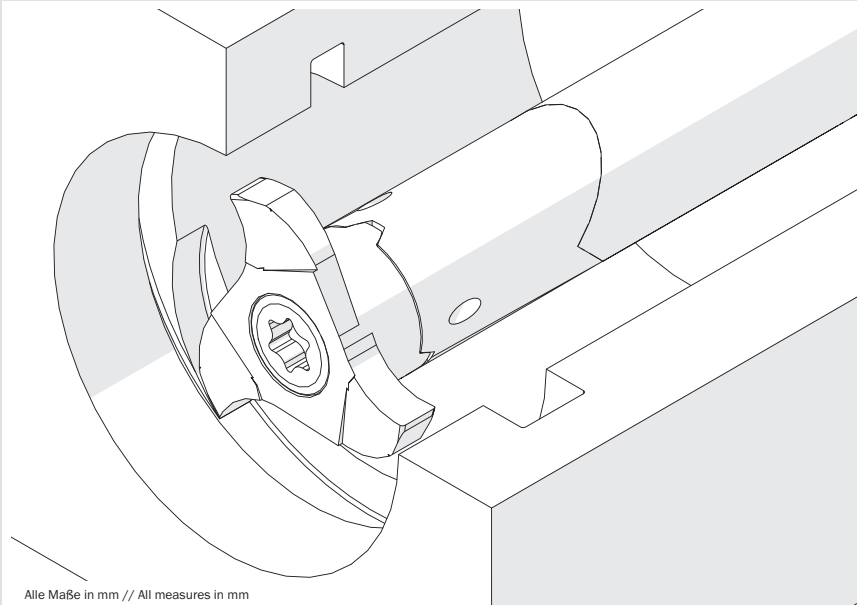
461

Anwendungsübersicht
Application overview

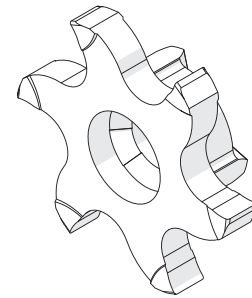
555

Alle Werkzeuge
All tools

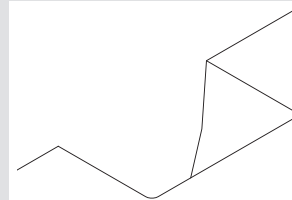
Allgemeines Nutfräsen General Groove Milling



Alle Maße in mm // All measures in mm



Auch als 6-Schneider verfügbar.
Also available with 6 cutting edges.

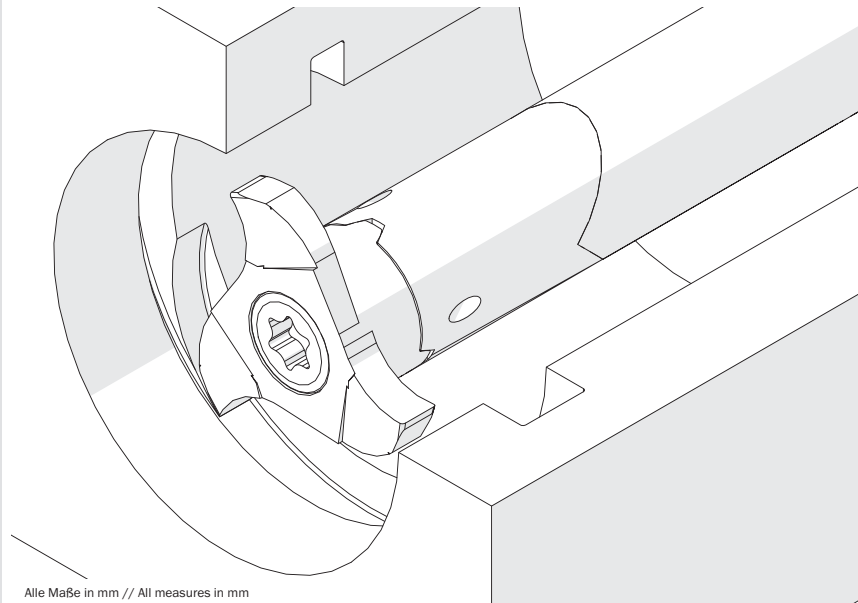


Artikelnummer Part number	ØDmin (Min. Bohrung) ØDmin (min. bore)	w	ZEFP	siehe Seite see Page
P10.0100.01 G	10,0	1,0	3	493
P10.0150.02 G	10,0	1,5	3	493
P10.0157.00 G	10,0	1,575	3	493
P10.0200.02 G	10,0	2,0	3	493
P10.0250.02 G	10,0	2,5	3	493
P12.0150.02 G	12,0	1,5	3	494
P06.0150.02.12 G	12,0	1,5	6	495
P06.0150.020.12 GY	12,0	1,5	6	496
P12.0157.02 G	12,0	1,575	3	494
P12.0200.02 G	12,0	2,0	3	494
P06.0200.02.12 G	12,0	2,0	6	495
P06.0200.020.12 GY	12,0	2,0	6	496
P12.0239.02 G	12,0	2,388	3	494
P12.0250.02 G	12,0	2,5	3	494
P12.0300.02 G	12,0	3,0	3	494
S14.0100.01 G	14,0	1,0	3	513
S14.0100.00 G	14,0	1,04	3	513
S14.0117.00 G	14,0	1,168	3	513
S14.0142.00 G	14,0	1,422	3	513
S14.0150.02 G	14,0	1,5	3	513
S14.0157.02 G	14,0	1,575	3	513
S14.0200.02 G	14,0	2,0	3	513
S14.0239.02 G	14,0	2,388	3	513
S14.0250.02 G	14,0	2,5	3	513
S16.0117.00 G	16,0	1,168	3	514
S16.0142.00 G	16,0	1,422	3	514
S16.0150.02 G	16,0	1,5	3	514
S06.0150.02.16 G	16,0	1,5	6	515
S06.0150.020.16 GY	16,0	1,5	6	517
S16.0157.02 G	16,0	1,575	3	514
S16.0200.02 G	16,0	2,0	3	514
S06.0200.02.16 G	16,0	2,0	6	515
S06.0200.020.16 GY	16,0	2,0	6	517
S16.0239.02 G	16,0	2,388	3	514
S16.0250.02 G	16,0	2,5	3	514
S06.0250.02.16 G	16,0	2,5	6	515
S06.0250.020.16 GY	16,0	2,5	6	517
S16.0318.02 G	16,0	3,175	3	514
U18.0117.00 G	18,0	1,168	3	539
U18.0142.00 G	18,0	1,422	3	539
U18.0150.02 G	18,0	1,5	3	539

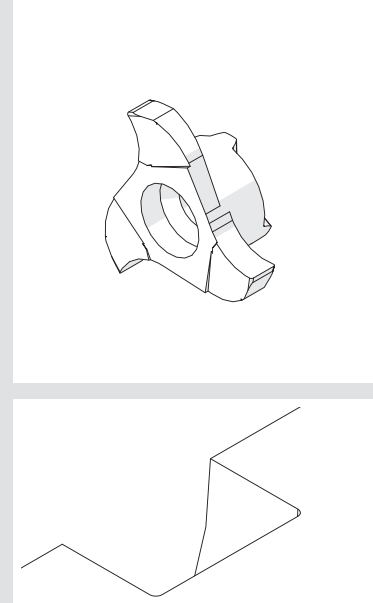
Artikelnummer Part number	ØDmin (Min. Bohrung) ØDmin (min. bore)	w	ZEFP	siehe Seite see Page
U06.0150.010.18 G	18,0	1,5	6	537
U18.0157.02 G	18,0	1,549	3	539
U18.0200.02 G	18,0	2,0	3	539
U06.0200.020.18 G	18,0	2,0	6	537
U06.0200.020.18 GY	18,0	2,0	6	541
U18.0239.02 G	18,0	2,388	3	539
U18.0250.02 G	18,0	2,5	3	539
U06.0250.020.18 G	18,0	2,5	6	537
U06.0250.020.18 GY	18,0	2,5	6	541
U18.0300.02 G	18,0	3,0	3	539
U06.0300.020.18 G	18,0	3,0	6	537
U06.0300.020.18 GY	18,0	3,0	6	541
U18.0318.02 G	18,0	3,175	3	539
U18.0400.02 G	18,0	4,0	3	539
U20.0150.02 G	20,0	1,5	3	540
U06.0150.010.20 G	20,0	1,5	6	538
U20.0200.02 G	20,0	2,0	3	540
U06.0200.020.20 G	20,0	2,0	6	538
U06.0200.020.20 GY	20,0	2,0	6	542
U20.0250.02 G	20,0	2,5	3	540
U06.0250.020.20 G	20,0	2,5	6	538
U06.0250.020.20 GY	20,0	2,5	6	542
U06.0300.020.20 G	20,0	3,0	6	538
U06.0300.020.20 GY	20,0	3,0	6	542
V22.0100.01 G	22,0	1,0	3	568
V06.0100.010.22 G	22,0	1,0	6	567
V06.0117.010.22 G	22,0	1,168	6	567
V22.0150.02 G	22,0	1,5	3	568
V06.0150.010.22 G	22,0	1,5	6	567
V22.0157.02 G	22,0	1,575	3	568
V06.0157.010.22 G	22,0	1,575	6	567
V22.0200.02 G	22,0	2,0	3	568
V06.0200.020.22 G	22,0	2,0	6	567
V06.0200.020.22 GY	22,0	2,0	6	569
V22.0239.02 G	22,0	2,388	3	568
V06.0238.020.22 G	22,0	2,388	6	567
V22.0250.02 G	22,0	2,5	3	568
V06.0250.020.22 G	22,0	2,5	6	567
V06.0250.020.22 GY	22,0	2,5	6	569
V22.0300.02 G	22,0	3,0	3	568
V06.0300.020.22 G	22,0	3,0	6	567

Artikelnummer Part number	ØDmin (Min. Bohrung) ØDmin (min. bore)	w	ZEFP	siehe Seite see Page
V06.0300.020.22 GY	22,0	3,0	6	569
V22.0318.02 G	22,0	3,175	3	568
V22.0318.04 G	22,0	3,175	3	568
V06.0318.020.22 G	22,0	3,175	6	567
V22.0350.02 G	22,0	3,5	3	568
V22.0356.02 G	22,0	3,566	3	568
V22.0400.02 G	22,0	4,0	3	568
V22.0400.04 G	22,0	4,0	3	568
V06.0400.020.22 G	22,0	4,0	6	567
V06.0400.020.22 GY	22,0	4,0	6	569
V22.0437.02 G	22,0	4,369	3	568
V22.0437.04 G	22,0	4,369	3	568
V22.0475.02 G	22,0	4,75	3	568
V22.0500.02 G	22,0	5,0	3	568
V22.0635.02 G	22,0	6,35	3	568
V25.0200.02 G	25,0	2,0	3	586
V25.0239.02 G	25,0	2,388	3	586
V25.0250.02 G	25,0	2,5	3	586
V06.0250.020.25 GY	25,0	2,5	6	570
V06.0265.020.25 GY	25,0	2,76	6	570
V25.0300.02 G	25,0	3,0	3	586
V06.0300.020.25 GY	25,0	3,0	6	570
V25.0318.02 G	25,0	3,175	3	586
V25.0350.02 G	25,0	3,5	3	586
V25.0400.02 G	25,0	4,0	3	586
V06.0400.020.25 GY	25,0	4,0	6	570
V25.0475.02 G	25,0	4,75	3	586
V25.0500.02 G	25,0	5,0	3	586
V06.0500.020.25 GY	25,0	5,0	6	570
V06.0600.020.25 GY	25,0	6,0	6	570
V06.0100.010.28 G	28,0	1,0	6	590
V06.0120.010.28 G	28,0	1,2	6	590
V28.0150.02 G	28,0	1,5	3	587
V06.0150.010.28 G	28,0	1,5	6	590
V06.0160.010.28 GY	28,0	1,71	6	570
V28.0200.02 G	28,0	2,0	3	587
V06.0200.020.28 G	28,0	2,0	6	590
V06.0200.020.28 GY	28,0	2,0	6	570
V28.0250.02 G	28,0	2,5	3	587
V06.0250.020.28 G	28,0	2,5	6	590
V06.0250.020.28 GY	28,0	2,5	6	570

Standardwerkzeuge // Standard Tools

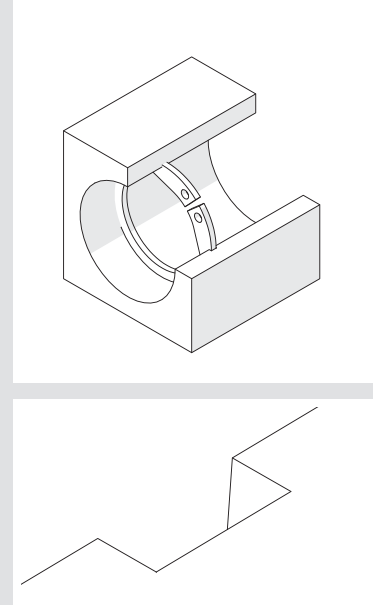
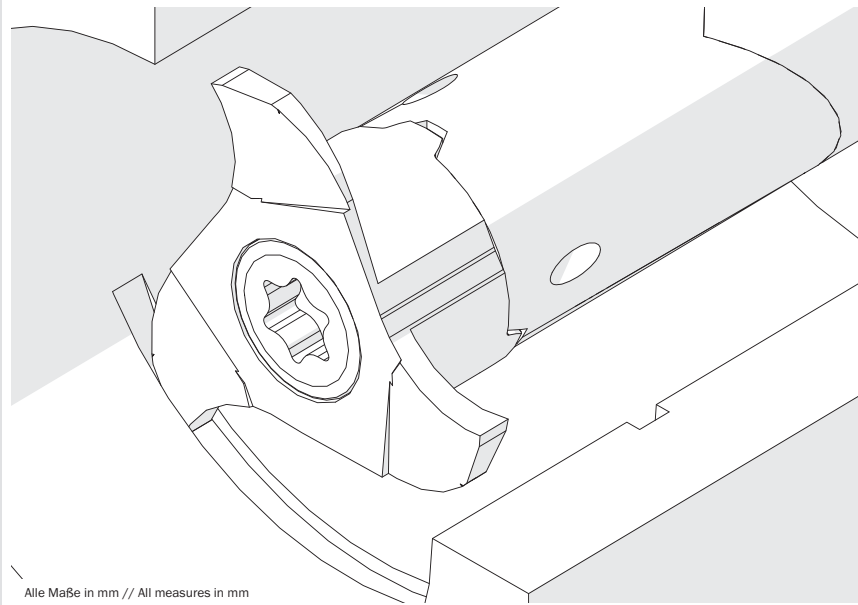
Allgemeines Nutfräsen in Leichtmetall
General Groove Milling in light alloys

Alle Maße in mm // All measures in mm



Artikelnummer Part number	ØDmin (Min. Bohrung) ØDmin (min. bore)	w	ZFP	siehe Seite see Page
P12.0150.42 C	12,0	1,5	3	497
P12.0200.42 C	12,0	2,0	3	497
P12.0250.42 C	12,0	2,5	3	497
S16.0100.40 C	16,0	1,04	3	518
S16.0200.42 C	16,0	2,0	3	518
S16.0250.42 C	16,0	2,5	3	518
U18.0150.42 C	18,0	1,5	3	543
U18.0200.42 C	18,0	2,0	3	543
U18.0250.42 C	18,0	2,5	3	543
U18.0300.42 C	18,0	3,0	3	543
V22.0150.42 C	22,0	1,5	3	573
V22.0200.42 C	22,0	2,0	3	573
V22.0250.42 C	22,0	2,5	3	573
V22.0300.42 C	22,0	3,0	3	573
V22.0400.42 C	22,0	4,0	3	573
V28.0200.42 C	28,0	2,0	3	592
V28.0250.42 C	28,0	2,5	3	592
V28.0300.42 C	28,0	3,0	3	592
V28.0350.42 C	28,0	3,5	3	592
V28.0400.42 C	28,0	4,0	3	592
V32.0200.42 C	32,0	2,0	3	596
V32.0250.42 C	32,0	2,5	3	596
V32.0300.42 C	32,0	3,0	3	596
V32.0600.42 C	32,0	6,0	3	596
V33.0110.42.10 C	33,0	1,1	3	597
V33.0120.42.10 C	33,0	1,2	3	597
V33.0132.42.10 C	33,0	1,32	3	597
V33.0150.42.10 C	33,0	1,5	3	597
V33.0160.42.10 C	33,0	1,6	3	597
V33.0170.42.10 C	33,0	1,7	3	597
V33.0200.42.10 C	33,0	2,0	3	597
V33.0250.42.10 C	33,0	2,5	3	597
V33.0170.42.12 C	33,9	1,7	3	597
V33.0200.42.12 C	33,9	2,0	3	597
V33.0250.42.12 C	33,9	2,5	3	597

Fräsen von Sicherungsringnuten, innen Circlip Ring Groove Milling, internal

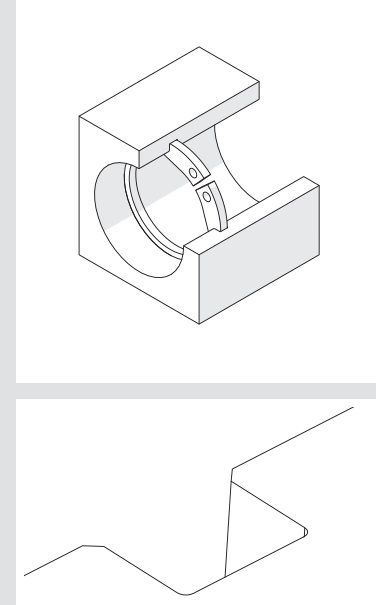
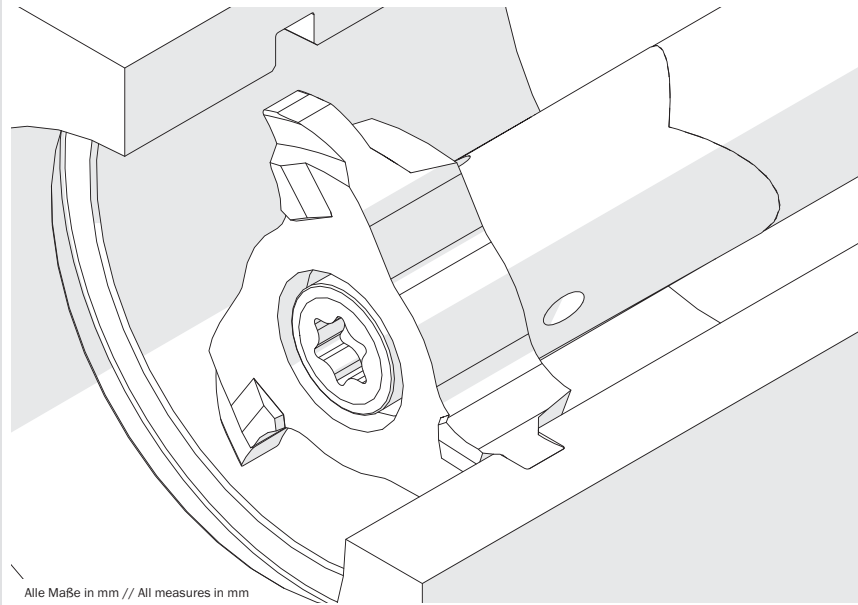


Alle Maße in mm // All measures in mm

Artikelnummer Part number	ØDmin (Min. Bohrung) ØDmin (min. bore)	Nuttenbreite Nominal width of groove	ZEFP	siehe Seite see Page
P10.0070.00 Z	10,0	0,7	3	490
P10.0080.00 Z	10,0	0,8	3	490
P10.0090.00 Z	10,0	0,9	3	490
P10.0100.00 G	10,0	1,0	3	490
P10.0110.00 G	10,0	1,1	3	490
P10.0130.01 G	10,0	1,3	3	490
P10.0160.01 G	10,0	1,6	3	490
P12.0110.00 G	12,0	1,1	3	491
P12.0110.40 C	12,0	1,1	3	492
P12.0130.01 G	12,0	1,3	3	491
P12.0130.41 C	12,0	1,3	3	492
P12.0160.01 G	12,0	1,6	3	491
P12.0160.41 C	12,0	1,6	3	492
S16.0160.01 G	16,0	1,6	3	516
U18.0070.00 Z	18,0	0,7	3	535
U18.0080.00 Z	18,0	0,8	3	535
U18.0090.00 Z	18,0	0,9	3	535
U18.0110.00 G	18,0	1,1	3	535
U18.0110.40 C	18,0	1,1	3	536
U06.0110.000.18 G	18,0	1,1	6	534
U18.0130.01 G	18,0	1,3	3	535
U18.0130.41 C	18,0	1,3	3	536
U06.0130.000.18 G	18,0	1,3	6	534
U18.0160.01 G	18,0	1,6	3	535
U18.0160.41 C	18,0	1,6	3	536
U06.0160.000.18 G	18,0	1,6	6	534
V22.0070.00 Z	22,0	0,7	3	565
V22.0080.00 Z	22,0	0,8	3	565
V22.0090.00 Z	22,0	0,9	3	565
V22.0100.00 Z	22,0	1,0	3	565
V22.0110.00 Z	22,0	1,1	3	565
V22.0130.01 G	22,0	1,3	3	565
V22.0130.41 C	22,0	1,3	3	566
V22.0160.01 G	22,0	1,6	3	565
V22.0160.41 C	22,0	1,6	3	566
V22.0185.02 G	22,0	1,85	3	565
V22.0185.42 C	22,0	1,85	3	566
V22.0215.02 G	22,0	2,15	3	565
V22.0215.42 C	22,0	2,15	3	566
V22.0265.02 G	22,0	2,65	3	565
V22.0265.42 C	22,0	2,65	3	566

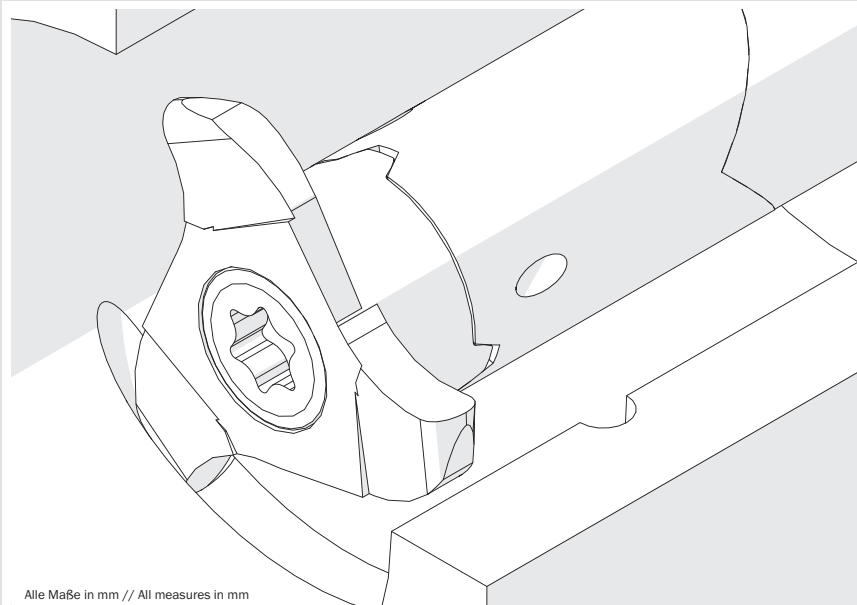
Artikelnummer Part number	ØDmin (Min. Bohrung) ØDmin (min. bore)	Nuttenbreite Nominal width of groove	ZEFP	siehe Seite see Page
V22.0315.02 G	22,0	3,15	3	565
V22.0315.42 C	22,0	3,15	3	566
V22.0415.02 G	22,0	4,15	3	565
V22.0415.42 C	22,0	4,15	3	566
V22.0515.02 G	22,0	5,15	3	565
V22.0515.04 G	22,0	5,15	3	565
V22.0515.42 C	22,0	5,15	3	566

Standardwerkzeuge // Standard Tools

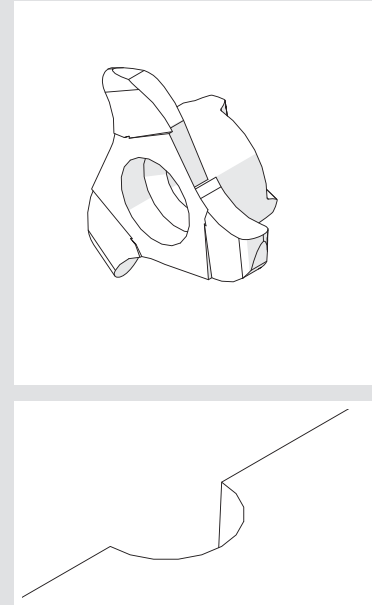
Fräsen von Sicherungsringuten mit Nutaußenkantenfasung
Circlip Ring Groove Milling with chamfering

Artikelnummer Part number	ØDmin (Min. Bohrung) ØDmin (min. bore)	Nuttenbreite Nominal width of groove	ZEFP	siehe Seite see Page
V22.1105.30 F	22,0	1,1	3	572
V22.1307.30 F	22,0	1,3	3	572
V22.1308.30 F	22,0	1,3	3	572
V22.1609.35 F	22,0	1,6	3	572
V22.1610.35 F	22,0	1,6	3	572
V22.1812.35 F	22,0	1,85	3	572
V22.2215.35 F	22,0	2,15	3	572
V22.2616.45 F	22,0	2,65	3	572
V22.2617.45 F	22,0	2,65	3	572
V22.3118.45 F	22,0	3,15	3	572
V22.4120.55 F	22,0	4,15	3	572
V22.4125.55 F	22,0	4,15	3	572

Fräsen von Vollradiusnuten Full Radius Groove Milling



Alle Maße in mm // All measures in mm



Artikelnummer Part number	ØDmin (Min. Bohrung) ØDmin (min. bore)	R	ZEPF	siehe Seite see Page
P12.0005.10 V	12,0	0,5	3	498
P12.0007.15 V	12,0	0,75	3	498
P12.0031.62 V	12,0	0,787	3	498
P12.0010.20 V	12,0	1,0	3	498
P12.0011.22 V	12,0	1,1	3	498
P12.0047.94 V	12,0	1,194	3	498
P12.0015.30 V	12,0	1,5	3	498
S16.0011.22 V	16,0	1,1	3	519
U18.0010.20 V	18,0	1,0	3	544
U18.0011.22 V	18,0	1,1	3	544
U18.0012.24 V	18,0	1,19	3	544
U18.0015.30 V	18,0	1,5	3	544
V22.0005.10 V	22,0	0,5	3	574
V22.0008.16 V	22,0	0,8	3	574
V22.0010.20 V	22,0	1,0	3	574
V22.0012.24 V	22,0	1,2	3	574
V22.0014.28 V	22,0	1,4	3	574
V22.0015.30 V	22,0	1,5	3	574
V22.0062.12 V	22,0	1,588	3	574
V22.0020.40 V	22,0	2,0	3	574
V22.0022.44 V	22,0	2,2	3	574
V22.0024.48 V	22,0	2,381	3	574
V22.0025.50 V	22,0	2,5	3	574
V22.0032.64 V	22,0	3,2	3	574
V25.0016.318 V	25,0	1,588	3	574
V28.0016.318 V	28,0	1,588	3	574
V28.0032.635 V	28,0	3,175	3	574

simmill AX

simmill PMX

simmill PX

simmill SX

simmill UX

simmill VX

simmill H2

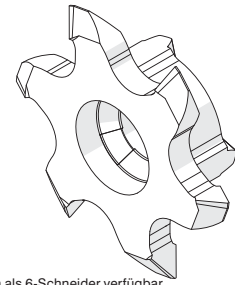
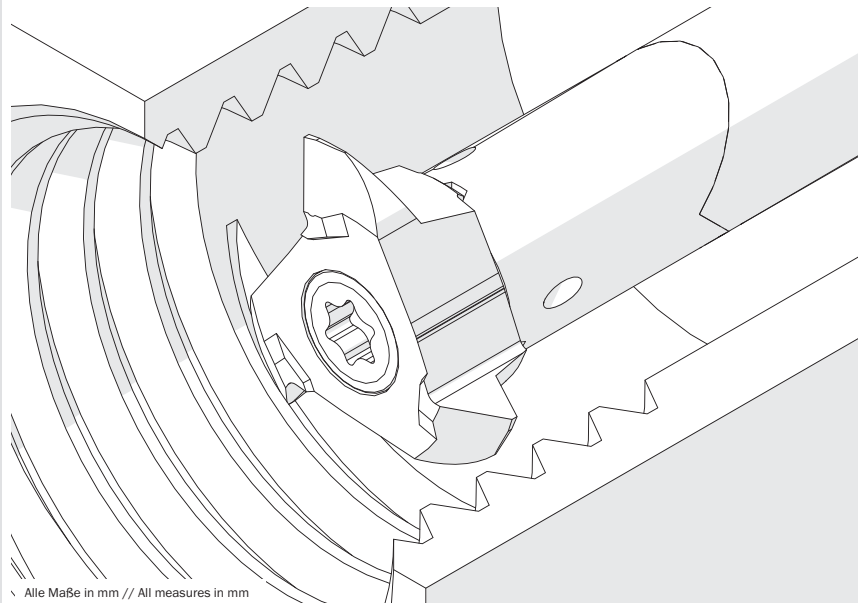
simmill K2

simmill MX

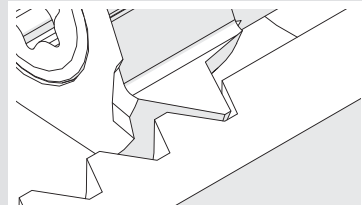
simmill OS

Index

Standardwerkzeuge // Standard Tools

Metrisches ISO-Gewindefräsen, Teilprofil
Thread milling, metric ISO-Thread, partial profile

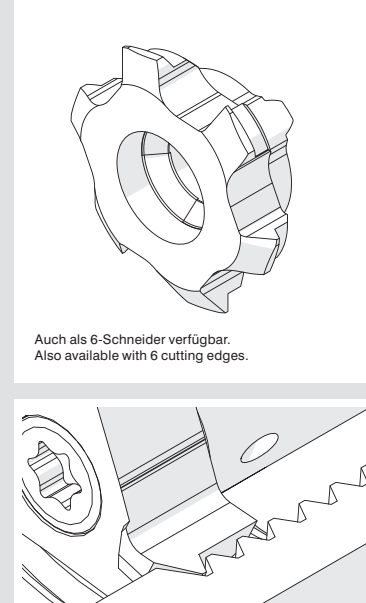
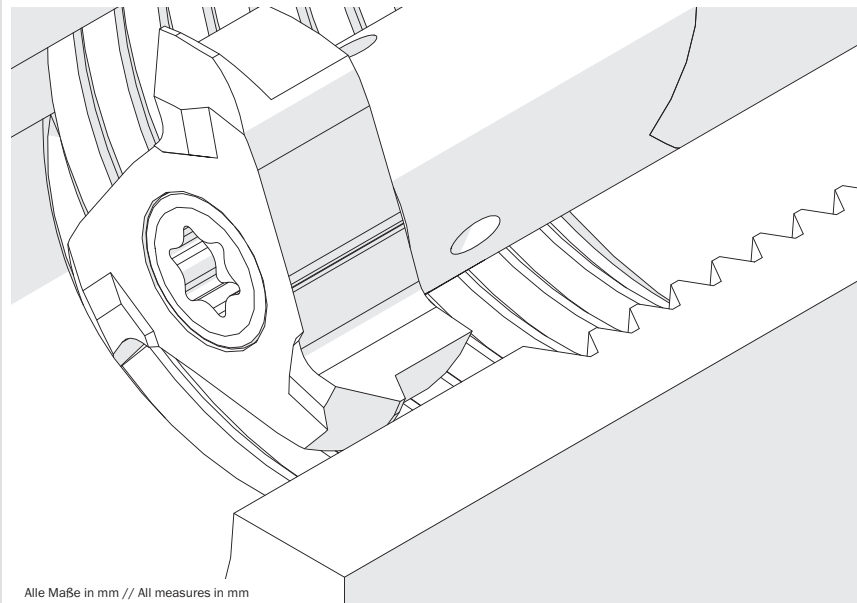
Auch als 6-Schneider verfügbar.
Also available with 6 cutting edges.



Artikelnummer Part number	Ab Gewindegröße As of thread size	Steigung (von) Pitch (as of)	Steigung (bis) Pitch (up to)	siehe Seite see Page
P06.0510.01.10 M	M12	1,0	1,75	499
P12.0510.01 M	M14	1,0	1,75	500
P06.0720.01.10 M	M14	1,0	2,0	499
P06.0720.01.12 M	M14	1,0	2,0	499
P12.0720.01 M	M14	1,0	2,0	500
S06.0510.01.12 M	M16	1,0	1,75	520
S06.0720.01.12 M	M16	1,0	2,0	520
P06.0815.01.11 M	M16	1,5	2,75	499
P12.0815.01 M	M16	1,5	2,75	500
P06.2530.01.11 M	M16	2,0	3,0	499
P12.2530.01 M	M16	2,0	3,0	500
S16.0510.01 M	M18	1,0	1,75	521
S16.0720.01 M	M18	1,0	2,0	521
S06.0815.01.13 M	M18	1,5	2,75	520
S06.2530.01.13 M	M18	2,0	3,0	520
S16.0815.01 M	M20	1,5	2,75	521
U18.0510.01 M	M22	1,0	1,75	548
U06.0720.01.18 M	M22	1,0	2,0	547
U18.0720.01 M	M22	1,0	2,0	548
U18.0815.01 M	M22	1,5	2,75	548
S16.2530.01 M	M22	2,5	3,0	521
U18.1325.01 M	M24	2,0	3,0	548
U18.1020.01 M	M24	2,0	3,75	548
U06.2535.01.18 M	M24	2,0	4,0	547
U18.2535.01 M	M24	2,0	4,0	548
U18.1630.01 M	M24	2,5	5,0	548
U18.1835.01 M	M24	3,0	5,5	548
V06.0720.01.22 M	M27	1,0	2,0	577
V22.0720.01 M	M27	1,0	2,0	578
V22.0815.01 M	M27	1,5	2,75	578
V22.1020.01 M	M27	2,0	3,75	578
V06.2545.01.22 M	M27	2,0	4,5	577
V22.2545.01 M	M27	2,5	4,5	578
V22.1630.01 M	M30	2,5	5,0	578
V22.2140.01 M	M30	3,5	6,0	578
V22.2445.01 M	M30	3,5	6,5	578
V28.0720.01 M	M33	1,0	2,0	594
V06.1525.01.28 M	M33	1,5	2,5	593
V28.1525.01 M	M33	1,5	2,5	594
V06.3050.01.28 M	M36	2,5	5,0	593
V28.3050.01 M	M36	2,5	5,0	594

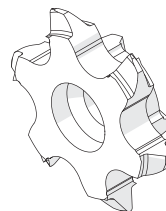
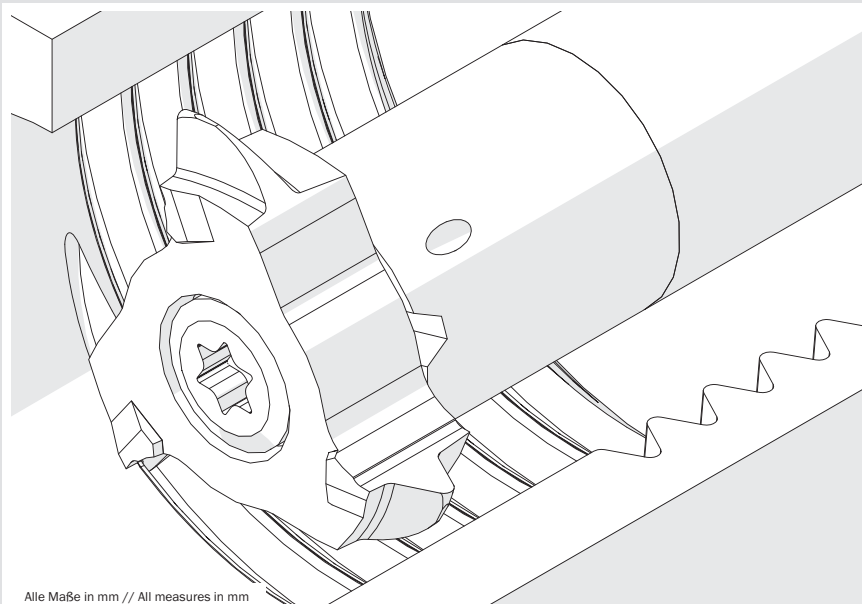
Artikelnummer Part number	Ab Gewindegröße As of thread size	Steigung (von) Pitch (as of)	Steigung (bis) Pitch (up to)	siehe Seite see Page
V28.5060.01 M	M39	4,0	6,0	594

Metrisches ISO-Gewindefräsen, Vollprofil Thread milling, metric ISO-Thread, full profile

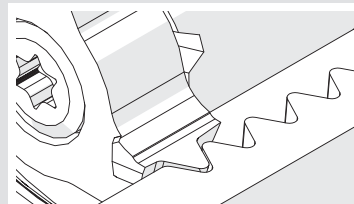


Artikelnummer Part number	Ab Gewindegröße As of thread size	Steigung (von) Pitch (as of)	ZFP	siehe Seite see Page
P10.0407.02 M	M14	0,75	3	501
P10.0510.02 M	M14	1,0	3	501
P10.0815.02 M	M14	1,5	3	501
S14.0510.02 M	M16	1,0	3	522
P10.0917.02 M	M16	1,75	3	501
P10.1020.02 M	M16	2,0	3	501
S14.0815.02 M	M18	1,5	3	522
P10.1325.02 M	M18	2,5	3	501
S14.0917.02 M	M20	1,75	3	522
S14.1020.02 M	M20	2,0	3	522
U18.0815.02 M	M22	1,5	3	546
U06.0815.02.18 M	M22	1,5	6	545
S14.1325.02 M	M22	2,5	3	522
S14.1630.02 M	M22	3,0	3	522
U18.0917.02 M	M24	1,75	3	546
V22.0815.02 M	M27	1,5	3	576
V06.0815.02.22 M	M27	1,5	6	575
U18.1020.02 M	M27	2,0	3	546
U06.1020.02.18 M	M27	2,0	6	545
U18.1325.02 M	M27	2,5	3	546
U18.1630.02 M	M27	3,0	3	546
U06.1630.02.18 M	M27	3,0	6	545
V22.0917.02 M	M30	1,75	3	576
V06.0917.02.22 M	M30	1,75	6	575
V22.1020.02 M	M30	2,0	3	576
V06.1020.02.22 M	M30	2,0	6	575
U18.1835.02 M	M30	3,5	3	546
U06.1835.02.18 M	M30	3,5	6	545
V22.1630.02 M	M33	3,0	3	576
V06.1630.02.22 M	M33	3,0	6	575
V22.1835.02 M	M33	3,5	3	576
V22.2140.02 M	M36	4,0	3	576
V06.2140.02.22 M	M36	4,0	6	575
V22.2445.02 M	M36	4,5	3	576

Standardwerkzeuge // Standard Tools

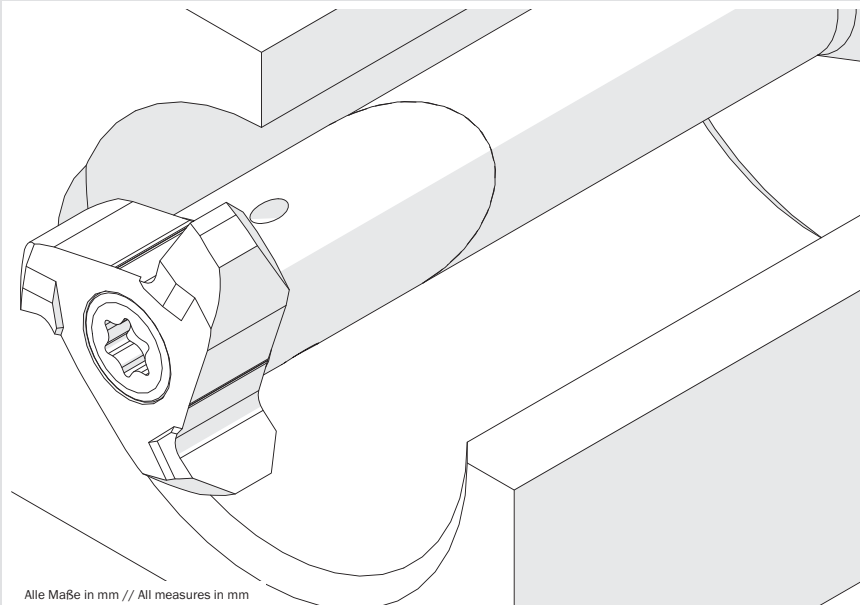
Whitworth-Gewinde, Vollprofil
Whitworth Thread, full profile

Auch als 6-Schneider verfügbar.
Also available with 6 cutting edges.

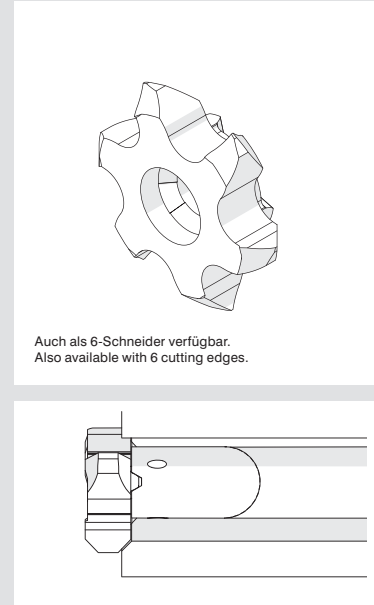


Artikelnummer Part number	Gang/Zoll Threads/Inch	ZEFP	siehe Seite see Page
P12.1423.11 M	11	3	503
S16.1423.11 M	11	3	524
U18.BS11.02 M	11	3	551
V22.5511.02 M	11	3	581
S06.1423.11.14 M	11	6	523
V06.5511.02.22 M	11	6	580
P12.1118.14 M	14	3	503
S16.1118.14 M	14	3	524
U18.BS14.02 M	14	3	551
S06.1118.14.14 M	14	6	523
P10.0813.19 M	19	3	503
P12.0813.19 M	19	3	503
U18.BS19.02 M	19	3	551
V22.5506.02 M	6	3	581
V06.5506.02.22 M	6	6	580
V22.5508.02 M	8	3	581
V06.5508.02.22 M	8	6	580

Fräsen von Fasen Chamfering



Alle Maße in mm // All measures in mm



Artikelnummer Part number	ØDmin (Min. Bohrung) ØDmin (min. bore)	ZEFP	siehe Seite see Page
P09.4545.02 F	9,6	3	505
P10.4545.35 F	10,0	3	505
P06.1515.02.10 F	10,0	6	504
P06.2020.02.10 F	10,0	6	504
P06.3030.02.10 F	10,0	6	504
P06.4545.02.10 F	10,0	6	504
P12.4545.35 F	12,0	3	505
S06.1515.02.14 F	14,0	6	525
S06.2020.02.14 F	14,0	6	525
S06.3030.02.14 F	14,0	6	525
S06.4545.02.14 F	14,0	6	525
U15.4545.58 F	15,0	3	552
U06.4545.050.15 F	15,0	6	553
S16.4545.02 F	16,0	3	526
S16.4545.45 F	16,0	3	526
U18.4545.20 F	18,0	3	552
U18.4545.58 F	18,0	3	552
U06.3030.020.18 F	18,0	6	553
U06.4545.020.18 F	18,0	6	553
V22.4545.58 F	22,0	3	582
V22.4545.94 F	22,0	3	582
V06.4545.020.22 F	22,0	6	583
V06.4545.020.28 F	28,0	6	583

simmill AX

simmill PMX

simmill PX

simmill SX

simmill UX

simmill VX

simmill H2

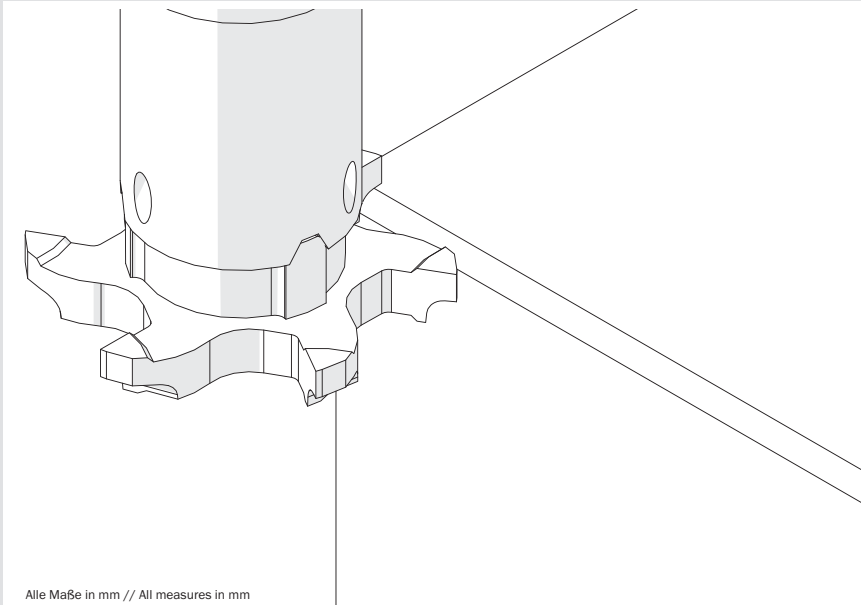
simmill K2

simmill MX

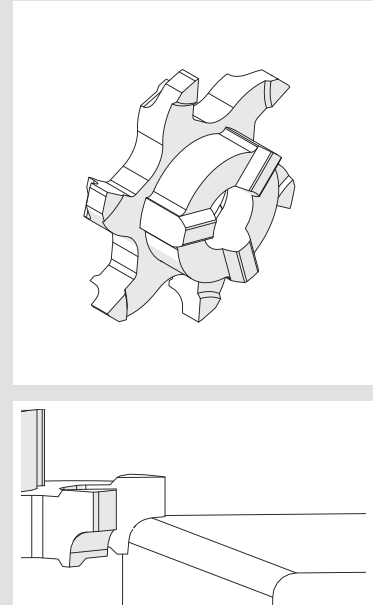
simmill OS

Index

Standardwerkzeuge // Standard Tools

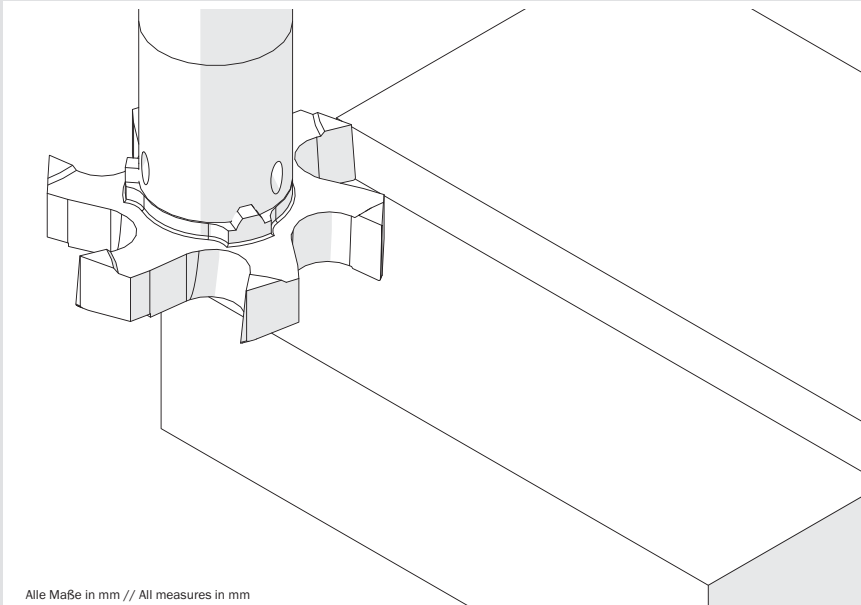
Fräsen von Kantenverrundungen (Entgraten)
Corner Rounding (Deburring)

Alle Maße in mm // All measures in mm

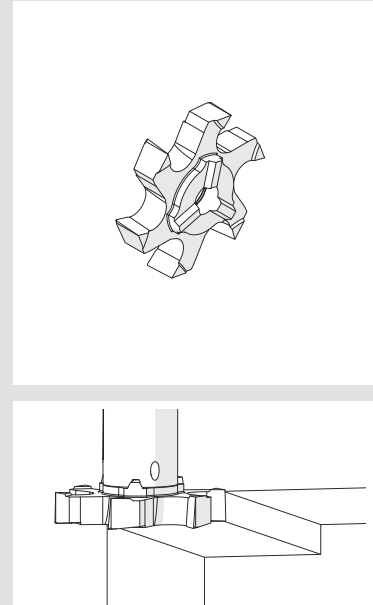


Artikelnummer Part number	R	ZEFP	siehe Seite see Page
V06.R020.22 F	0,2	6	584
V06.R050.22 F	0,5	6	584
V06.R060.22 F	0,6	6	584
V06.R080.22 F	0,8	6	584
V06.R100.22 F	1,0	6	584
V06.R125.22 F	1,25	6	584
V06.R150.22 F	1,5	6	584
V06.R200.22 F	2,0	6	584
V06.R225.22 F	2,25	6	584
V06.R250.22 F	2,5	6	584
V06.R300.22 F	3,0	6	584

Stirn- und Planfräsen Face Milling



Alle Maße in mm // All measures in mm



Artikelnummer Part number	ØDS	ZEFF // ZEFP	siehe Seite see Page
U06.PL55.020.18 Y	17,7	6	554
U06.ST40.020.18 Y	17,7	6	554
V06.PL50.020.20 Y	19,7	6	585
V06.ST40.020.22 Y	21,7	6	585
V06.PL50.020.28 Y	27,7	6	585

simmill AX

simmill PMX

simmill PX

simmill SX

simmill UX

simmill VX

simmill H2

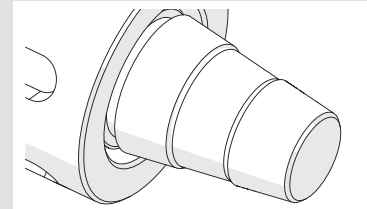
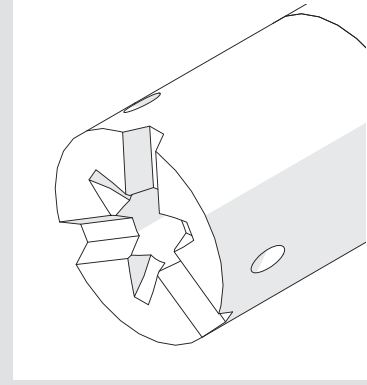
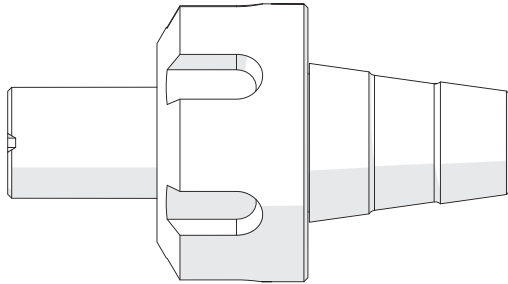
simmill K2

simmill MX

simmill OS

Index

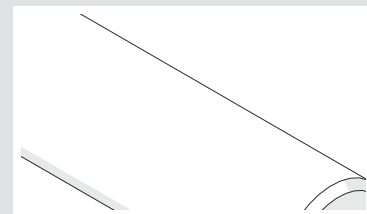
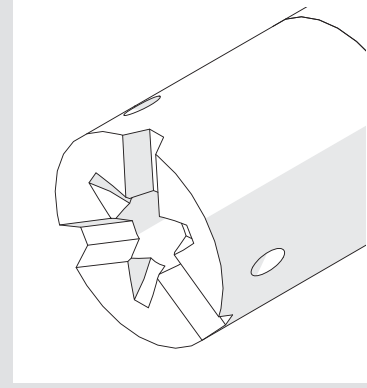
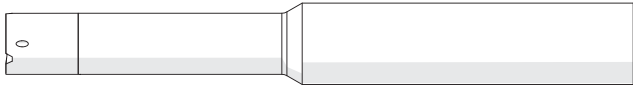
Standardwerkzeuge // Standard Tools

Fräserschaft, für Spannzangenfutter (DIN 6499)
Milling cutter shank, for collet chucks (DIN 6499)

Alle Maße in mm // All measures in mm

Artikelnummer Part number	Für Spannzange For collet chuck	siehe Seite see Page
P10.ER11.06.16	ER11	489
P10.ER11.06.16.B	ER11	489
S14.ER11.08.16	ER11	512
S14.ER11.08.16.B	ER11	512
U18.ER11.09.22	ER11	533
U18.ER11.09.22.B	ER11	533
S14.ER16.08.22	ER16	512
S14.ER16.08.22.B	ER16	512
S14.ER16.08.22.C	ER16	512
U18.ER16.09.22	ER16	533
U18.ER16.09.22.B	ER16	533
U18.ER16.09.22.C	ER16	533
V22.ER16.12.30	ER16	563
V22.ER16.12.30.B	ER16	563
V22.ER16.12.30.C	ER16	563
S14.ER20.08.22	ER20	512
S14.ER20.08.22.B	ER20	512
U18.ER20.09.22	ER20	533
U18.ER20.09.22.B	ER20	533
V22.ER20.12.30	ER20	563
V22.ER20.12.30.B	ER20	563
V28.ER20.14.35	ER20	563
V28.ER20.14.35.B	ER20	563
U18.ER25.09.22	ER25	533
U18.ER25.09.22.B	ER25	533
V22.ER25.12.30	ER25	563
V22.ER25.12.30.B	ER25	563
V22.ER25.14.19	ER25	563
V22.ER25.14.19.B	ER25	563
V28.ER25.14.35	ER25	563
V28.ER25.14.35.B	ER25	563
V22.ER32.12.30	ER32	563
V22.ER32.14.19	ER32	563
V28.ER32.14.35	ER32	563

Fräserschaft aus Hartmetall, zylindrisch (vgl. DIN 6535 HA)
 Solid Carbide Milling Cutter Shank, cylindrical (DIN 6535 HA)



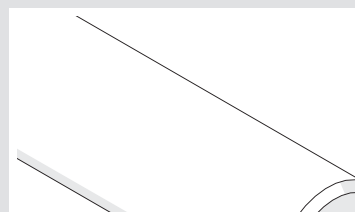
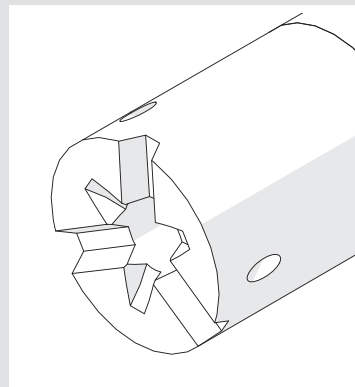
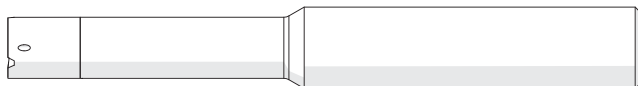
Alle Maße in mm // All measures in mm

Artikelnummer Part number	ØDh6	siehe Seite see Page
P10.1206.21 A HM	12,0	485
P10.1206.30 A HM	12,0	485
P10.1206.42 A HM	12,0	485
P10.1207.30 A HM	12,0	485
S14.1208.29 A HM	12,0	508
S14.1208.42 A HM	12,0	508
S14.1208.56 A HM	12,0	508
S14.1209.42 A HM	12,0	508
U18.1209.32 A HM	12,0	529
U18.1209.45 A HM	12,0	529
U18.1209.64 A HM	12,0	529
V22.1212.42 A HM	12,0	556
V22.1212.60 A HM	12,0	556
P10.0.500.06.21 A HM	12,7	485
P10.0.500.06.30 A HM	12,7	485
P10.0.500.06.42 A HM	12,7	485
P10.0.500.07.30 A HM	12,7	485
S14.0.500.08.29 A HM	12,7	508
S14.0.500.08.42 A HM	12,7	508
S14.0.500.08.56 A HM	12,7	508
S14.0.500.09.42 A HM	12,7	508
U18.0.500.09.32 A HM	12,7	529
U18.0.500.09.45 A HM	12,7	529
U18.0.500.09.64 A HM	12,7	529
V22.0.500.13.42 A HM	12,7	557
V22.0.500.13.60 A HM	12,7	557
P10.0.625.07.25 A HM	15,875	485
S14.0.625.09.33 A HM	15,875	508
U18.0.625.09.25 A HM	15,875	529
U18.0.625.09.32 A HM	15,875	529
U18.0.625.09.45 A HM	15,875	529
U18.0.625.09.64 A HM	15,875	529
U18.0.625.13.64 A HM	15,875	529
U18.0.625.13.66 A HM	15,875	529
V22.0.625.11.30 A HM	15,875	557
V22.0.625.12.42 A HM	15,875	557
V22.0.625.12.60 A HM	15,875	557
V22.0.625.12.85 A HM	15,875	557
V28.0.625.14.42 A HM	15,875	557
V28.0.625.14.60 A HM	15,875	557
V28.0.625.14.85 A HM	15,875	557

Artikelnummer Part number	ØDh6	siehe Seite see Page
P10.1607.25 A HM	16,0	485
S14.1609.33 A HM	16,0	508
U18.1609.25 A HM	16,0	529
U18.1609.32 A HM	16,0	529
U18.1609.45 A HM	16,0	529
U18.1609.64 A HM	16,0	529
U18.1613.64 A HM	16,0	529
U18.1613.66 A HM	16,0	529
V22.1611.30 A HM	16,0	556
V22.1612.42 A HM	16,0	556
V22.1612.60 A HM	16,0	556
V22.1612.85 A HM	16,0	556
V28.1614.42 A HM	16,0	556
V28.1614.60 A HM	16,0	556
V28.1614.85 A HM	16,0	556
V33.1609.33 A HM	16,0	556
V22.2016.45 A HM	20,0	556
V22.2016.65 A HM	20,0	556
V28.2013.35 A HM	20,0	556
V28.2014.85 A HM	20,0	556

Standardwerkzeuge // Standard Tools

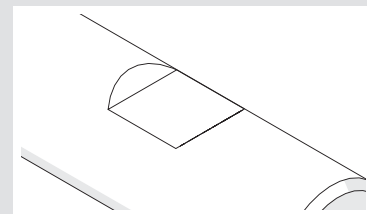
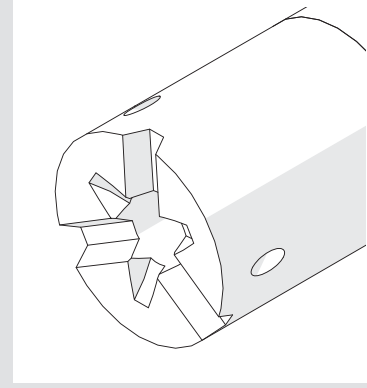
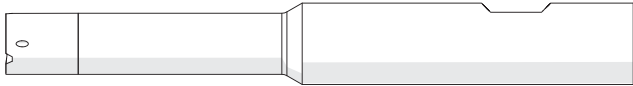
Fräserschaft aus Stahl, zylindrisch (vgl. DIN 1835 A)
Steel Milling Cutter Shank, cylindrical (DIN 1835 A)



Alle Maße in mm // All measures in mm

Artikelnummer Part number	ØDh6	siehe Seite see Page
P10.1006.15 A ST	10,0	486
S14.1008.17 A ST	10,0	509
U18.1009.17 A ST	10,0	530
V22.1011.10 A ST	10,0	558
U18.1209.18 A ST	12,0	530
S14.1308.25 A ST	13,0	509
U18.1309.25 A ST	13,0	530
V22.1311.25 A ST	13,0	558
V28.1314.10 A ST	13,0	558
P10.0.625.06.12 A ST	15,875	486
S14.0.625.08.16 A ST	15,875	509
U18.0.625.09.18 A ST	15,875	530
V22.0.625.12.24 A ST	15,875	558
P10.1606.12 A ST	16,0	486
S14.1608.16 A ST	16,0	509
U18.1609.18 A ST	16,0	530
V22.1612.24 A ST	16,0	558
V28.0.750.14.35 A ST	19,05	558
V28.2014.35 A ST	20,0	558

Fräserschaft aus Hartmetall, Weldon (vgl. DIN 6535 HB)
 Solid Carbide Milling Cutter Shank, Weldon (DIN 6535 HB)

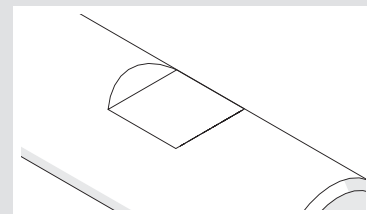
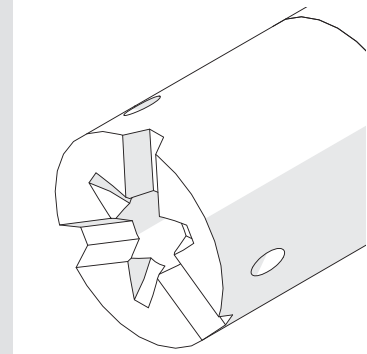
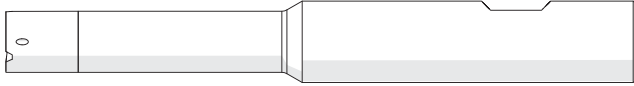


Alle Maße in mm // All measures in mm

Artikelnummer Part number	ØDh6	siehe Seite see Page
P10.1206.21 B HM	12,0	487
P10.1206.30 B HM	12,0	487
P10.1206.42 B HM	12,0	487
P10.1207.30 B HM	12,0	487
S14.1208.29 B HM	12,0	510
S14.1208.42 B HM	12,0	510
S14.1208.56 B HM	12,0	510
S14.1209.42 B HM	12,0	510
U18.1209.32 B HM	12,0	531
U18.1209.45 B HM	12,0	531
U18.1209.64 B HM	12,0	531
V22.1212.42 B HM	12,0	559
V22.1212.60 B HM	12,0	559
P10.0.500.06.21 B HM	12,7	487
P10.0.500.06.30 B HM	12,7	487
P10.0.500.06.42 B HM	12,7	487
P10.0.500.07.30 B HM	12,7	487
S14.0.500.08.29 B HM	12,7	510
S14.0.500.08.42 B HM	12,7	510
S14.0.500.08.56 B HM	12,7	510
S14.0.500.09.42 B HM	12,7	510
U18.0.500.09.32 B HM	12,7	531
U18.0.500.09.45 B HM	12,7	531
U18.0.500.09.64 B HM	12,7	531
V22.0.500.13.42 B HM	12,7	560
V22.0.500.13.60 B HM	12,7	560
P10.0.625.07.25 B HM	15,875	487
S14.0.625.09.33 B HM	15,875	510
U18.0.625.09.25 B HM	15,875	531
U18.0.625.09.32 B HM	15,875	531
U18.0.625.09.45 B HM	15,875	531
U18.0.625.09.64 B HM	15,875	531
U18.0.625.13.64 B HM	15,875	531
U18.0.625.13.66 B HM	15,875	531
V22.0.625.11.30 B HM	15,875	560
V22.0.625.12.42 B HM	15,875	560
V22.0.625.12.60 B HM	15,875	560
V22.0.625.12.85 B HM	15,875	560
V28.0.625.14.42 B HM	15,875	560
V28.0.625.14.60 B HM	15,875	560
V28.0.625.14.85 B HM	15,875	560

Artikelnummer Part number	ØDh6	siehe Seite see Page
V33.0.625.09.33 B HM	15,875	560
P10.1607.25 B HM	16,0	487
S14.1609.33 B HM	16,0	510
U18.1609.25 B HM	16,0	531
U18.1609.32 B HM	16,0	531
U18.1609.45 B HM	16,0	531
U18.1609.64 B HM	16,0	531
U18.1612.45 B HM	16,0	531
U18.1613.64 B HM	16,0	531
U18.1613.66 B HM	16,0	531
V22.1611.30 B HM	16,0	559
V22.1612.42 B HM	16,0	559
V22.1612.60 B HM	16,0	559
V22.1612.85 B HM	16,0	559
V28.1614.42 B HM	16,0	559
V28.1614.60 B HM	16,0	559
V28.1614.85 B HM	16,0	559
V33.1609.33 B HM	16,0	559
V22.2016.45 B HM	20,0	559
V22.2016.65 B HM	20,0	559
V28.2013.35 B HM	20,0	559
V28.2014.85 B HM	20,0	559

Standardwerkzeuge // Standard Tools

Fräserschaft aus Stahl, Weldon (vgl. DIN 1835 B)
Steel Milling Cutter Shank, Weldon (DIN 1835 B)

Alle Maße in mm // All measures in mm

Artikelnummer Part number	ØDh6	siehe Seite see Page
U18.1209.18 B ST	12,0	532
S14.0.625.08.16 B ST	15,875	511
U18.0.625.09.18 B ST	15,875	532
V22.0.625.12.24 B ST	15,875	561
V33.0.625.09.20 B ST	15,875	561
S14.1608.16 B ST	16,0	511
U18.1609.18 B ST	16,0	532
V22.1612.24 B ST	16,0	561
V33.1609.20 B ST	16,0	561
V28.2014.35 B ST	20,0	561



Ab Seite // As of page

461

Anwendungsübersicht
Application overview

simmill AX

simmill PMX

simmill PX

simmill SX

simmill UX

simmill VX

simmill H2

simmill K2

simmill MX

simmill OS

Index

477

Fräserschaft, zylindrisch (vgl. DIN 6535 HA)

Schwingungsgedämpfte Hartmetall-Ausführung mit innerer Kühlmittelzufuhr und Aufnahme nach DIN 6535 HA.

Milling Cutter Shank, cylindrical (DIN 6535 HA)

Anti-vibration solid carbide type with through coolant and shank according to DIN 6535 HA.

Anzugsmoment (Schraube) // Tightening torque (screw)

1,2 Nm

Bitte Hinweise im Anhang beachten // Please read add. notes

ALL (Seite/Page 645)



Legende
 Legend **650**



Scan
 QR-Code

Oder besuchen Sie // Or Visit
www.simtek.info/cp/1370

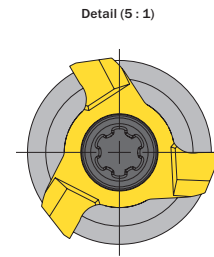
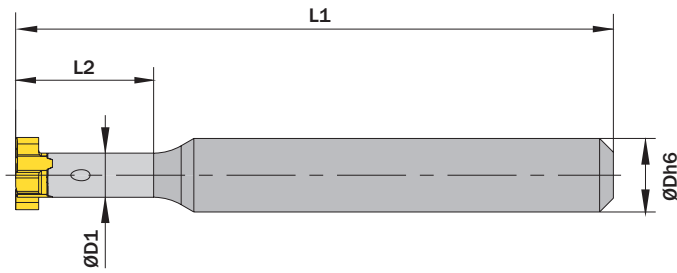


Abbildung zeigt / Drawing shows: PM0.0805.17 A HM

ØDh6	ØD1	L2	Artikelnummer Part number	Webcode www.simtek.com/webcode	L1	Schraube Screw	Schraubenschlüssel Screw driver	Connectcode www.simtek.com/ccode	
mm	mm	mm			mm				
8,0	4,8	17,0	PM0.0805.17 A HM	A5VX	65,0	D M2x7,5 T7F	T7F	PM04.8	new
8,0	4,8	25,0	PM0.0805.25 A HM	A5VZ	75,0	D M2x7,5 T7F	T7F	PM04.8	new
8,0	4,8	35,0	PM0.0805.35 A HM	A5V1	85,0	D M2x7,5 T7F	T7F	PM04.8	new

Bestellbeispiel // Order example: **PM0.0805.35 A HM**

Fräuserschaft, zylindrisch (vgl. DIN 1835 A)

Stahl-Ausführung mit Aufnahme nach DIN 1835 A.

Milling Cutter Shank, cylindrical (DIN 1835 A)

Steel type with shank according to DIN 1835 A.

Anzugsmoment (Schraube) // Tightening torque (screw)
1,2 Nm

Bitte Hinweise im Anhang beachten // Please read add. notes
ALL (Seite/Page 645)

TW

ST

Legende
Legend

650

Scan QR-Code Oder besuchen Sie // Or Visit www.simtek.info/cp/1372

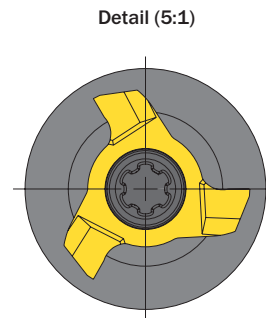
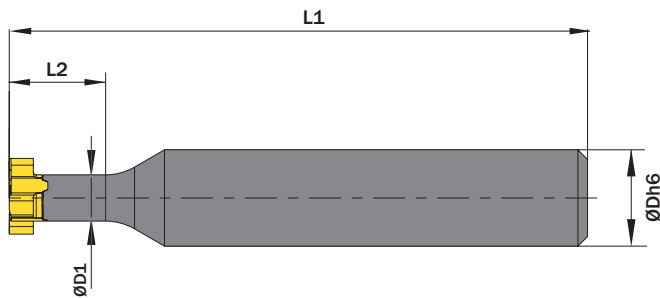


Abbildung zeigt / Drawing shows: PM0.1005.10 A ST

ØDh6	ØD1	L2	Artikelnummer Part number	Webcode www.simtek.com/webcode	L1	Schraube Screw	Schraubenschlüssel Screw driver	Connectcode www.simtek.com/code
mm	mm	mm			mm	D M2x7,5 T7F	T7F	PM04.8 <small>new</small>
10,0	4,8	10,0	PM0.1005.10 A ST	A5VV	60,0			

Bestellbeispiel // Order example: **PM0.1005.10 A ST**

Zirkularfräsen // Groove Milling
 simmill PM > Schneidwerkzeug // Cutting Tool



Fräsen von Sicherungsringnuten, innen

Fräsen von Sicherungsringnuten in Bohrungen ab Bohrungsdurchmesser 7,0 mm. Geeignet für alle Materialien.

Circlip Ring Groove Milling, internal

Circlip ring groove milling in bores as of bore diameter 7,0 mm. For use in all materials.

Schnittwerte (Start) // Cutting parameters (start)

fzm 0,02 mm	hmax 0,03 mm	Vc Seite/Page 638
-----------------------	------------------------	-----------------------------

Passende Klemmhalter auf Seite // Suitable toolholders on page
478, 479

Bitte Hinweise im Anhang beachten // Please read add. notes

ALL (Seite/Page 645), H01 (Seite/Page 646), H07 (Seite/Page 648)



SP Legende
HM Legend

650



Scan QR-Code

Oder besuchen Sie // Or Visit
www.simtek.info/cp/1387

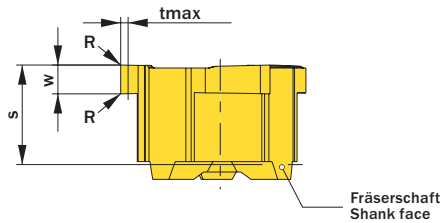
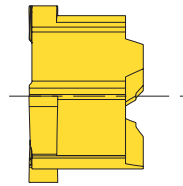
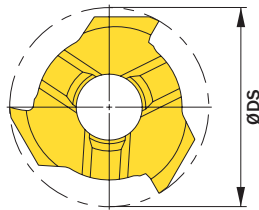


Abbildung zeigt / Drawing shows: PM7.0090.00 G

w _{-0,02}	Nuttenbreite Nominal width of groove	R	ØDmin (Min. Bohrung) ØDmin (min. bore)	Artikelnummer Part number	Webcode www.simtek.com/webcode	Unsere erste Wahl Our first choice	tmax	S	ØDS	ZEFP	Connectcode www.simtek.com/ccode	
mm	mm	mm	mm			P M K N S	mm	mm	mm			
0,97	0,9	-	7,0	PM7.0090.00 G	A63X	X800 GT42	0,6	3,35	6,7	3	PM04.8	new
1,07	1,0	-	7,0	PM7.0100.00 G	A63Z	X800 GT42	0,6	3,35	6,7	3	PM04.8	new
1,24	1,1	-	7,0	PM7.0110.00 G	A631	X800 GT42	0,6	3,35	6,7	3	PM04.8	new

Bestellbeispiel // Order example: **PM7.0110.00 G X800** (X800 = Schneidstoff // Grade)

simmill AX

simmill PMX

simmill PX

simmill SX

simmill UX

simmill VX

simmill H2

simmill K2

simmill MX

simmill OS

Index

Nut-, Trenn- und Schlitzfräsen

Nut-, Trenn- und Schlitzfräsen in Bohrungen ab Bohrungsdurchmesser 7,0 mm.

Groove, Slot and Key Way Milling

Groove, slot and key way milling in bores as of minimum bore diameter 7,0 mm.

Schnittwerte (Start) // Cutting parameters (start)

fzm 0,02 mm	hmax 0,03 mm	Vc Seite/Page 638
-----------------------	------------------------	-----------------------------

Passende Klemmhalter auf Seite // Suitable toolholders on page
478, 479

Bitte Hinweise im Anhang beachten // Please read add. notes
ALL (Seite/Page 645), H01 (Seite/Page 646), H07 (Seite/Page 648)

SP

HM

Legende
Legend

650

Scan QR-Code

Oder besuchen Sie // Or Visit www.simtek.info/cp/1388

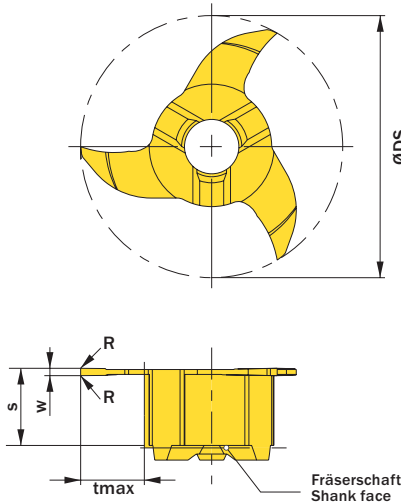


Abbildung zeigt / Drawing shows: PM9.0030.00.11 S

w ^{+0,02} mm	R mm	ØDmin (Min. Bohrung) ØDmin (min. bore) mm	Artikelnummer Part number	Webcode www.simtek.com/webcode	Unsere erste Wahl Our first choice	tmax mm	S mm	ØDS mm	ZEFP	Connectcode www.simtek.com/code		
					P M K N S							
▼ ØDmin (Min. Bohrung) // ØDmin (min. bore) = 7,0 mm												
0,5	-	7,0	PM7.0050.00 S	A633	X800 GT42	0,6	3,15	6,7	3	PM04.8	new	
1,0	-	7,0	PM7.0100.00 S	A635	X800 GT42	0,6	3,15	6,7	3	PM04.8	new	
▼ ØDmin (Min. Bohrung) // ØDmin (min. bore) = 8,0 mm												
0,3	-	8,0	PM8.0030.00 S	A637	X800 GT42	1,1	3,15	7,7	3	PM04.8	new	
0,4	-	8,0	PM8.0040.00 S	A639	X800 GT42	1,1	3,15	7,7	3	PM04.8	new	
0,5	-	8,0	PM8.0050.00 S	A64B	X800 GT42	1,1	3,15	7,7	3	PM04.8	new	
0,6	-	8,0	PM8.0060.00 S	A64D	X800 GT42	1,1	3,15	7,7	3	PM04.8	new	
0,7	-	8,0	PM8.0070.00 S	A64F	X800 GT42	1,1	3,15	7,7	3	PM04.8	new	
0,8	-	8,0	PM8.0080.00 S	A64H	X800 GT42	1,1	3,15	7,7	3	PM04.8	new	
0,9	-	8,0	PM8.0090.00 S	A64K	X800 GT42	1,1	3,15	7,7	3	PM04.8	new	
1,0	-	8,0	PM8.0100.00 S	A64N	X800 GT42	1,1	3,15	7,7	3	PM04.8	new	
▼ ØDmin (Min. Bohrung) // ØDmin (min. bore) = 9,0 mm												
1,0	-	9,0	PM9.0100.00 S	A64Q	X800 GT42	1,6	3,15	8,7	3	PM04.8	new	
▼ ØDmin (Min. Bohrung) // ØDmin (min. bore) = 11,0 mm												
0,3	-	11,0	PM9.0030.00.11 S	A64T	X800 GT42	2,6	3,15	10,7	3	PM04.8	new	
0,4	-	11,0	PM9.0040.00.11 S	A64V	X800 GT42	2,6	3,15	10,7	3	PM04.8	new	
0,5	-	11,0	PM9.0050.00.11 S	A64X	X800 GT42	2,6	3,15	10,7	3	PM04.8	new	

Bestellbeispiel // Order example: **PM8.0070.00 S X800** (X800 = Schneidstoff // Grade)

Metrisches ISO-Gewindefräsen, Teilprofil

Ausgelegt als Mehrbereichswerkzeuge. Die angegebene „Steigung (von)“ ist normgerecht. Die „Steigung (bis)“ kann ebenfalls realisiert werden. Vgl. Hinweistexte.

Thread milling, metric ISO-Thread, partial profile

Multi-purpose milling inserts. The given „Pitch (as of)“ is conforming to standards. The „Pitch (up to)“ is possible too at the expense of conformity. Please read additional notes.

Schnittwerte (Start) // Cutting parameters (start)

fzm 0,02 mm	hmax 0,03 mm	Vc Seite/Page 638
-----------------------	------------------------	-----------------------------

Passende Klemmhalter auf Seite // Suitable toolholders on page
478, 479

Bitte Hinweise im Anhang beachten // Please read add. notes

ALL (Seite/Page 645), H03 (Seite/Page 647), H04 (Seite/Page 648), H07 (Seite/Page 648)



SP Legende
HM Legend

650

Scan QR-Code Oder besuchen Sie // Or Visit
www.simtek.info/cp/1389

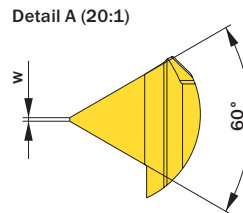
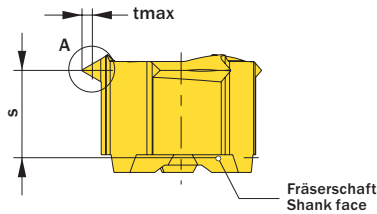
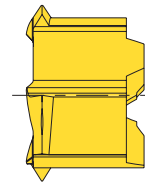
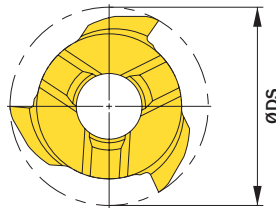


Abbildung zeigt / Drawing shows: PM7.MT.0405.01 M

Ab Gewindegröße As of thread size	Alternativ ab Nennmesser Alternativ as of nominal diameter	Steigung (von) Pitch (as of)	Steigung (bis) Pitch (up to)	Artikelnummer Part number	Webcode www.simtek.com/webcode	Unsere erste Wahl Our first choice		b	S	w ^{+0,02}	tmax	ØDS	ZEFP	Connectcode www.simtek.com/ccode	new
						P M K N S	G T								
M10	7,9	0,4	0,5	PM7.MT.0405.01 M	A64Z	X800	G142	3,15	2,95	0,03	0,35	6,7	3	PM04.8	new
M10	9,5	0,5	1,0	PM8.MT.0510.01 M	A641	X800	G142	3,15	2,95	0,04	0,68	7,7	3	PM04.8	new

Bestellbeispiel // Order example: **PM8.MT.0510.01 M X800** (X800 = Schneidstoff // Grade)

Metrisches ISO-Gewindefräsen, Vollprofil

Fräsen von metrischen ISO-Gewinden, Vollprofil.
 Geeignet ab Bohrungsdurchmesser 7,0 mm.

Thread milling, metric ISO-Thread, full profile

Thread milling of metric ISO-threads, full profile.
 For use in bores as of minimum bore diameter 7,0 mm.

Schnittwerte (Start) // Cutting parameters (start)

fzm 0,02 mm	hmax 0,03 mm	Vc Seite/Page 638
-----------------------	------------------------	-----------------------------

Passende Klemmhalter auf Seite // Suitable toolholders on page
478, 479

Bitte Hinweise im Anhang beachten // Please read add. notes
ALL (Seite/Page 645), H06 (Seite/Page 648), H07 (Seite/Page 648)

SP

Legende

HM

Legend

650

Scan QR-Code Oder besuchen Sie // Or Visit
www.simtek.info/cp/1390

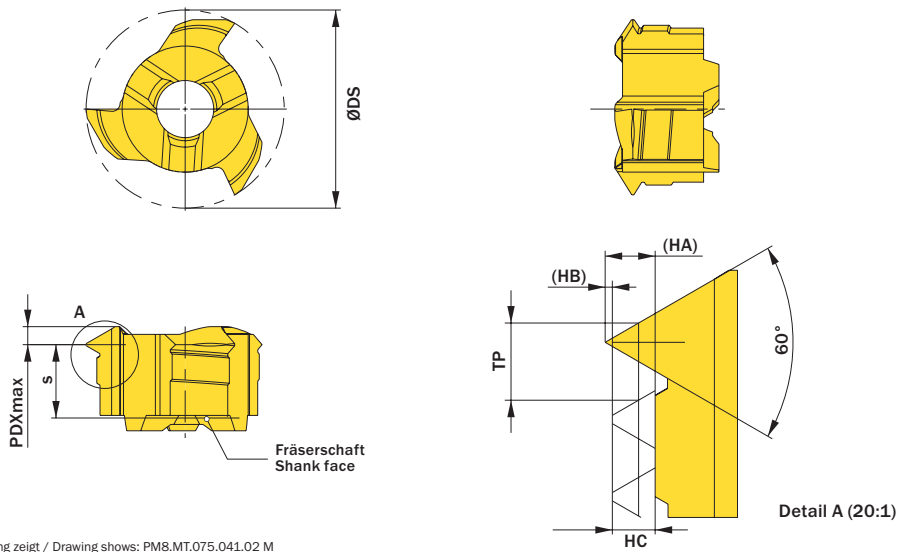


Abbildung zeigt / Drawing shows: PM8.MT.075.041.02 M

Ab Gewindegröße As of thread size	Alternativ ab Nenn Durchmesser Alternativ as of nominal diameter	HA	HB	HC	Steigung TP Pitch TP	Artikelnummer Part number	Webcode www.simtek.com/webcode	Unsere erste Wahl Our first choice		ZEPF	PDXmax	ØDS	S	Connectcode www.simtek.com/ccode	
								TP	S						
M8	7,5	0,26	0,04	0,22	0,4	PM7.MT.040.022.02 M	A643	X800	GT42	3	0,6	6,7	2,9	PM04.8	new
M8	7,5	0,29	0,05	0,24	0,45	PM7.MT.045.024.02 M	A645	X800	GT42	3	0,6	6,7	2,9	PM04.8	new
M8	7,6	0,32	0,05	0,27	0,5	PM7.MT.050.027.02 M	A647	X800	GT42	3	0,6	6,7	2,85	PM04.8	new
M8	7,7	0,39	0,06	0,32	0,6	PM7.MT.060.032.02 M	A649	X800	GT42	3	0,65	6,7	2,8	PM04.8	new
M8	7,8	0,45	0,08	0,38	0,7	PM7.MT.070.038.02 M	A65B	X800	GT42	3	0,65	6,7	2,75	PM04.8	new
M10	8,9	0,49	0,08	0,41	0,75	PM8.MT.075.041.02 M	A65D	X800	GT42	3	0,8	7,7	2,75	PM04.8	new
M10	9,0	0,52	0,09	0,43	0,8	PM8.MT.080.043.02 M	A65F	X800	GT42	3	0,8	7,7	2,75	PM04.8	new
M10	9,5	0,65	0,11	0,54	1,0	PM8.MT.100.054.02 M	A65H	X800	GT42	3	0,9	7,7	2,65	PM04.8	new

Bestellbeispiel // Order example: **PM7.MT.060.032.02 M X800** (X800 = Schneidstoff // Grade)

simmill AX
simmill PMX
simmill PX
simmill SX
simmill UX
simmill VX
simmill H2
simmill K2
simmill MX
simmill OS
Index

simmillPX
SIMTEK milling tools type PX



Ab Seite // As of page

461

Anwendungsübersicht
Application overview

Fräserschaft, zylindrisch (vgl. DIN 6535 HA)

Schwingungsgedämpfte Hartmetall-Ausführung mit innerer Kühlmittelzufuhr und Aufnahme nach DIN 6535 HA.





Milling Cutter Shank, cylindrical (DIN 6535 HA)


Anti-vibration solid carbide type with through coolant and shank according to DIN 6535 HA.

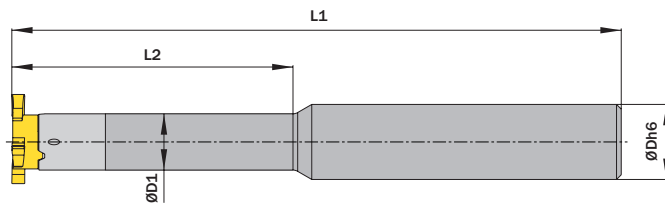
Anzugsmoment (Schraube) // Tightening torque (screw)
1,2 Nm

Vergleichbare Werkzeuge auf Seite // Similar tools on page
473

Bitte Hinweise im Anhang beachten // Please read add. notes
ALL (Seite/Page 645)

    Legende Legend **650**

 Scan QR-Code Oder besuchen Sie // Or Visit www.simtek.info/cp/346



ØDh6	ØD1	L2	Artikelnummer Part number	Webcode www.simtek.com/webcode	L1	Schraube Screw	Schraubenschlüssel Screw driver	Connectcode www.simtek.com/code	
mm	mm	mm			mm				
▼ ØDh6 = 12,0 mm									
12,0	6,0	21,0	P10.1206.21 A HM	AE35	80,0	P M2,6x8 T8F	T8F	PD06.0	
12,0	6,0	30,0	P10.1206.30 A HM	AG5A	90,0	P M2,6x8 T8F	T8F	PD06.0	
12,0	6,0	42,0	P10.1206.42 A HM	AMEK	100,0	P M2,6x8 T8F	T8F	PD06.0	
12,0	7,3	30,0	P10.1207.30 A HM	AHBF	90,0	P M2,6x8 T8F	T8F	PD07.3	
▼ ØDh6 = 12,7 mm									
12,7	6,0	21,0	P10.0.500.06.21 A HM	AE25	80,0	P M2,6x8 T8F	T8F	PD06.0 <small>Inch</small>	
12,7	6,0	30,0	P10.0.500.06.30 A HM	AKHS	90,0	P M2,6x8 T8F	T8F	PD06.0 <small>Inch</small>	
12,7	6,0	42,0	P10.0.500.06.42 A HM	AMMM	100,0	P M2,6x8 T8F	T8F	PD06.0 <small>Inch</small>	
12,7	7,3	30,0	P10.0.500.07.30 A HM	APFF	90,0	P M2,6x8 T8F	T8F	PD07.3 <small>Inch</small>	
▼ ØDh6 = 15,875 mm									
15,875	7,3	25,0	P10.0.625.07.25 A HM	AF2B	100,0	P M2,6x8 T8F	T8F	PD07.3 <small>Inch</small>	
▼ ØDh6 = 16,0 mm									
16,0	7,3	25,0	P10.1607.25 A HM	ADVZ	100,0	P M2,6x8 T8F	T8F	PD07.3	

Bestellbeispiel // Order example: **P10.1206.21 A HM**

simmill AX

simmill PMX

simmill PX

simmill SX

simmill UX

simmill VX

simmill H2

simmill K2

simmill MX

simmill OS

Index

Fräserschaft, zylindrisch (vgl. DIN 1835 A)

Stahl-Ausführung mit Aufnahme nach DIN 1835 A.

Milling Cutter Shank, cylindrical (DIN 1835 A)

Steel type with shank according to DIN 1835 A.

Anzugsmoment (Schraube) // Tightening torque (screw)

1,2 Nm

Vergleichbare Werkzeuge auf Seite // Similar tools on page
474

Bitte Hinweise im Anhang beachten // Please read add. notes

ALL (Seite/Page 645)

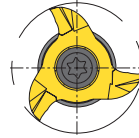
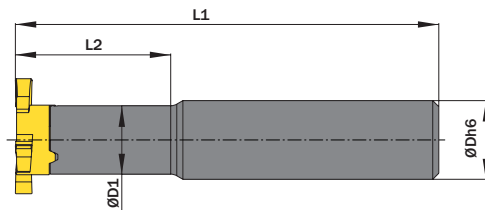


Legende **650**
Legend



Scan QR-Code

Oder besuchen Sie // Or Visit
www.simtek.info/cp/388



ØDh6 mm	ØD1 mm	L2 mm	Artikelnummer Part number	Webcode www.simtek.com/webcode	Mit Kühlmittelzufuhr With through coolant supply	L1 mm	Schraube Screw	Schraubenschlüssel Screw driver	Connectcode www.simtek.com/ccode
▼ ØDh6 = 10,0 mm									
10,0	6,0	15,0	P10.1006.15 A ST	AG7K	Nein / No	60,0	P M2,6x8 T8F	T8F	PD06.0
▼ ØDh6 = 15,875 mm									
15,875	6,0	12,0	P10.0.625.06.12 A ST	ABXD	Ja / Yes	80,0	P M2,6x8 T8F	T8F	PD06.0
▼ ØDh6 = 16,0 mm									
16,0	6,0	12,0	P10.1606.12 A ST	AE8E	Ja / Yes	80,0	P M2,6x8 T8F	T8F	PD06.0

Inch

Bestellbeispiel // Order example: **P10.1006.15 A ST**

Fräserschaft, Weldon (vgl. DIN 6535 HB)

Schwingungsgedämpfte Hartmetall-Ausführung mit innerer Kühlmittelzufuhr und Aufnahme nach DIN 6535 HB.

Milling Cutter Shank, Weldon (DIN 6535 HB)

Anti-vibration solid carbide type with through coolant and shank according to DIN 6535 HB.

Anzugsmoment (Schraube) // Tightening torque (screw)

1,2 Nm

Vergleichbare Werkzeuge auf Seite // Similar tools on page
475

Bitte Hinweise im Anhang beachten // Please read add. notes

ALL (Seite/Page 645)

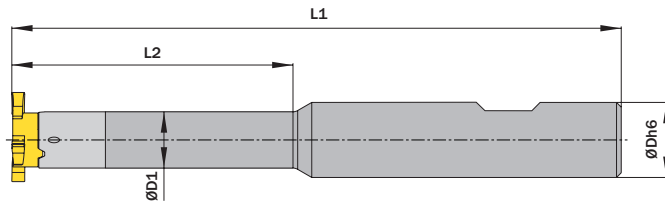


Legende
Legend **650**

Scan
QR-Code

Oder besuchen Sie // Or Visit
www.simtek.info/cp/347

Whistle-Notch Aufnahme auf Anfrage erhältlich.
Whistle-Notch fixation available upon request.



ØDh6	ØD1	L2	Artikelnummer Part number	Webcode www.simtek.com/webcode	L1	Schraube Screw	Schraubenschlüssel Screw driver	Connectcode www.simtek.com/code	
▼ ØDh6 = 12,0 mm									
12,0	6,0	21,0	P10.1206.21 B HM	AKJM	80,0	P M2,6x8 T8F	T8F	PD06.0	
12,0	6,0	30,0	P10.1206.30 B HM	AC5B	90,0	P M2,6x8 T8F	T8F	PD06.0	
12,0	6,0	42,0	P10.1206.42 B HM	AHUG	100,0	P M2,6x8 T8F	T8F	PD06.0	
12,0	7,3	30,0	P10.1207.30 B HM	AHJ7	90,0	P M2,6x8 T8F	T8F	PD07.3	
▼ ØDh6 = 12,7 mm									
12,7	6,0	21,0	P10.0.500.06.21 B HM	AFUZ	80,0	P M2,6x8 T8F	T8F	PD06.0 <small>inch</small>	
12,7	6,0	30,0	P10.0.500.06.30 B HM	AJXS	90,0	P M2,6x8 T8F	T8F	PD06.0 <small>inch</small>	
12,7	6,0	42,0	P10.0.500.06.42 B HM	ABXZ	100,0	P M2,6x8 T8F	T8F	PD06.0 <small>inch</small>	
12,7	7,3	30,0	P10.0.500.07.30 B HM	AEDG	90,0	P M2,6x8 T8F	T8F	PD07.3 <small>inch</small>	
▼ ØDh6 = 15,875 mm									
15,875	7,3	25,0	P10.0.625.07.25 B HM	ADDD	100,0	P M2,6x8 T8F	T8F	PD07.3 <small>inch</small>	
▼ ØDh6 = 16,0 mm									
16,0	7,3	25,0	P10.1607.25 B HM	APØF	100,0	P M2,6x8 T8F	T8F	PD07.3	

Bestellbeispiel // Order example: **P10.1206.30 B HM**

simmill AX

simmill PMX

simmill PX

simmill SX

simmill UX

simmill VX

simmill H2

simmill K2

simmill MX

simmill OS

Index

Fräserschaft, Weldon (vgl. DIN 1835 B)

Stahl-Ausführung mit Aufnahme nach DIN 1835 B.

Milling Cutter Shank, Weldon (DIN 1835 B)

Steel type with shank according to DIN 1835 B.

Anzugsmoment (Schraube) // Tightening torque (screw)

1,2 Nm

Vergleichbare Werkzeuge auf Seite // Similar tools on page
476

Bitte Hinweise im Anhang beachten // Please read add. notes

ALL (Seite/Page 645)



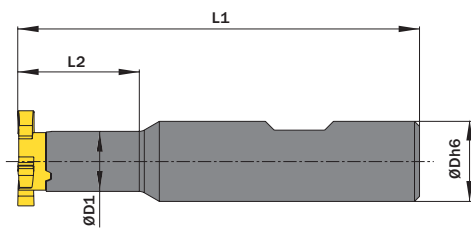
Legende
Legend **650**



Scan
QR-Code

Oder besuchen Sie // Or Visit
www.simtek.info/cp/420

Whistle-Notch Aufnahme auf Anfrage erhältlich.
Whistle-Notch fixation available upon request.



ØDg6	ØD1	L2	Artikelnummer Part number	Webcode www.simtek.com/webcode	Mit Kühlmittelzufuhr With through coolant supply	L1	Schraube Screw	Schraubenschlüssel Screw driver	Connectcode www.simtek.com/ccode
mm	mm	mm				mm			
15,875	6,0	12,0	P10.0.625.06.12 B ST	AH0P	Ja / Yes	80,0	P M2,6x8 T8F	T8F	PD06.0
10,0	6,0	15,0	P10.1006.15 B ST	AGS0	Nein / No	60,0	P M2,6x8 T8F	T8F	PD06.0
12,0	6,0	15,0	P10.1206.15 B ST	AK28	Ja / Yes	74,0	P M2,6x8 T8F	T8F	PD06.0
16,0	6,0	12,0	P10.1606.12 B ST	AAB7	Ja / Yes	80,0	P M2,6x8 T8F	T8F	PD06.0

Bestellbeispiel // Order example: **P10.1206.15 B ST**

Fräserschaft, für Spannzangenfutter (DIN 6499)

Für Spannzangenfutter nach DIN6499-A.

Milling cutter shank, for collet chucks (DIN6499)

For collet chucks according to DIN6499-A.

Anzugsmoment (Schraube) // Tightening torque (screw)

1,2 Nm

Vergleichbare Werkzeuge auf Seite // Similar tools on page
472

Bitte Hinweise im Anhang beachten // Please read add. notes
ALL (Seite/Page 645)



TW
ST

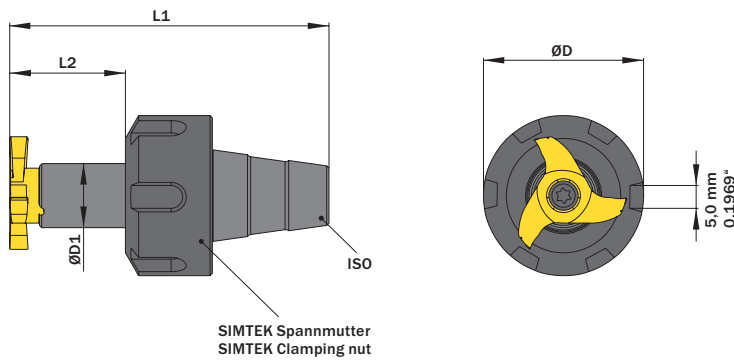
Legende
Legend

650



Scan
QR-Code

Oder besuchen Sie // Or Visit
www.simtek.info/cp/452



Fräserschaft ist nur mit passender Spannmutter verfügbar.
Spannmutter ist auch einzeln als Ersatzteil verfügbar.
Milling cutter shank is only available together with clamping nut.
Clamping nut is available as a spare part.

Für Spannzange For collet chuck	ØD1	L2	Artikelnummer Part number	Webcode www.simtek.com/webcode	Spannmutter Clamping nut	Gewinde Spannmutter Thread clamping nut	ØD	L1	Schraube Screw	Schraubenschlüssel Screw driver	Connectcode www.simtek.com/code
	mm	mm					mm	mm			
ER11	6,0	16,0	P10.ER11.06.16	AJFH	PER11.12.19	M14x0,75	19,0	36,3	P M2,6x8 T8F	T8F	PD06.0
ER11	6,0	16,0	P10.ER11.06.16.B	AVMP	PER11.12.16	M13x0,75	16,0	36,3	P M2,6x8 T8F	T8F	PD06.0

Bestellbeispiel // Order example: **P10.ER11.06.16**

Fräsen von Sicherungsringnuten, innen

Fräsen von Sicherungsringnuten in Bohrungen ab Bohrungsdurchmesser 10,0 mm. Geeignet für alle Materialien.

Circlip Ring Groove Milling, internal

Circlip ring groove milling in bores as of bore diameter 10,0 mm. For use in all materials.

Schnittwerte (Start) // Cutting parameters (start)		
fzm 0,02 mm	hmax 0,03 mm	Vc Seite/Page 638

Passende Klemhalter auf Seite // Suitable toolholders on page
485, 486, 487, 488, 489

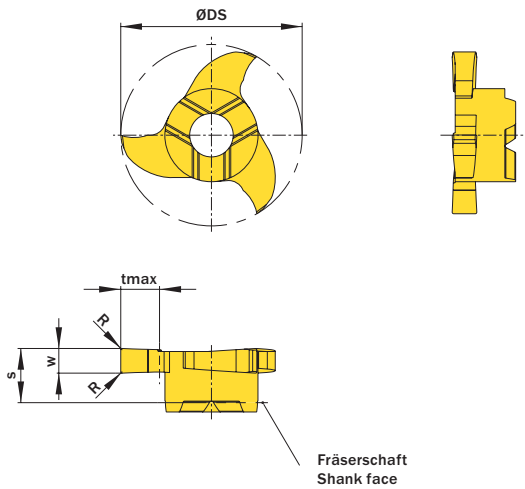
Vergleichbare Werkzeuge auf Seite // Similar tools on page
463

Bitte Hinweise im Anhang beachten // Please read add. notes
ALL (Seite/Page 645), H01 (Seite/Page 646), H07 (Seite/Page 648)

SP Legende
HM Legend

Scan
 Oder besuchen Sie // Or Visit
www.simtek.info/cp/349

650



Fräserschaft
 Shank face

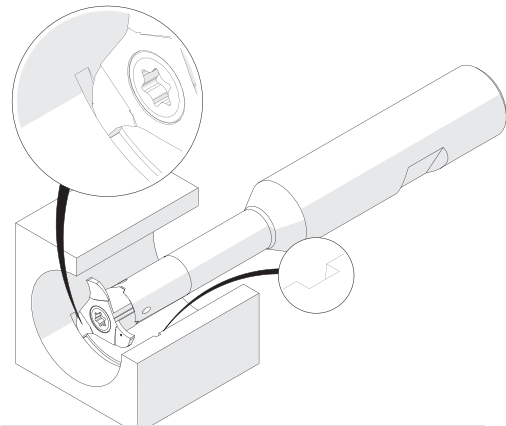


Illustration zeigt beispielhafte Anwendungsmöglichkeit mit ähnlichem Werkzeug.
 Image shows exemplary application possibility with similar tool.

Abbildung zeigt / Drawing shows: P12.0160.01 G

w ^{-0,02}	Nuttenbreite Nominal width of groove	R	ØDmin (Min.-Bohrung) ØDmin (min. bore)	Artikelnummer Part number	Webcode www.simtek.com/webcode	Unsere erste Wahl Our first choice	tmax	S	ØDS	ZEFP	Connectcode www.simtek.com/ccode	
mm	mm	mm	mm			P M K N S	mm	mm	mm			upd
0,77	0,7	-	10,0	P10.0070.00 Z	AHB1	X800 GT42	1,5	3,4	9,7	3	PD06.0	upd
0,87	0,8	-	10,0	P10.0080.00 Z	AKU6	X800 GT42	1,5	3,4	9,7	3	PD06.0	upd
0,97	0,9	-	10,0	P10.0090.00 Z	AG93	X800 GT42	1,5	3,4	9,7	3	PD06.0	upd
1,07	1,0	-	10,0	P10.0100.00 G	AA4Q	X800 GT42	1,5	3,4	9,7	3	PD06.0	upd
1,24	1,1	-	10,0	P10.0110.00 G	AJ8Z	X800 GT42	1,5	3,5	9,7	3	PD06.0	upd
1,44	1,3	0,1	10,0	P10.0130.01 G	AJVP	X800 GT42	1,5	3,5	9,7	3	PD06.0	upd
1,74	1,6	0,1	10,0	P10.0160.01 G	AGG7	X800 GT42	1,5	3,5	9,7	3	PD06.0	upd

Bestellbeispiel // Order example: **P10.0070.00 Z X800** (X800 = Schneidstoff // Grade)



P10. w. 1/100 mm, 4 Stellen/Digits . R. 1/100 mm, 3 Stellen/Digits

Toleranz // Tolerance

Beispielartikelnummer // Example Part number: **P10.0179.030 XG**

Fräsen von Sicherungsringnuten, innen

Fräsen von Sicherungsringnuten in Bohrungen ab Bohrungsdurchmesser 12,0 mm. Geeignet für alle Materialien.

Circlip Ring Groove Milling, internal

Circlip ring groove milling in bores as of bore diameter 12,0 mm. For use in all materials.

Schnittwerte (Start) // Cutting parameters (start)		
fzm 0,02 mm	hmax 0,03 mm	Vc Seite/Page 638
Passende Klemmhalter auf Seite // Suitable toolholders on page 485, 486, 487, 488, 489		
Vergleichbare Werkzeuge auf Seite // Similar tools on page 463		
Bitte Hinweise im Anhang beachten // Please read add. notes ALL (Seite/Page 645), H01 (Seite/Page 646), H07 (Seite/Page 648)		

SP Legende
HM Legend

Scan
 Oder besuchen Sie // Or Visit
www.simtek.info/cp/367

Legende Legend **650**

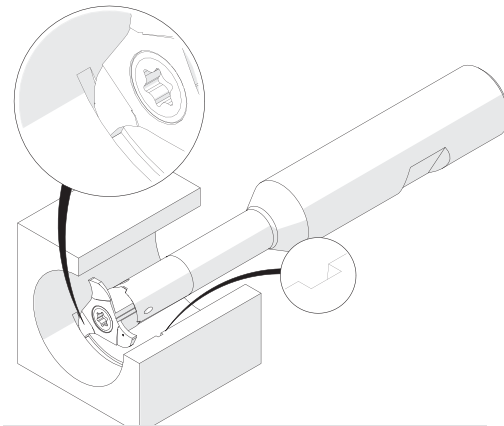
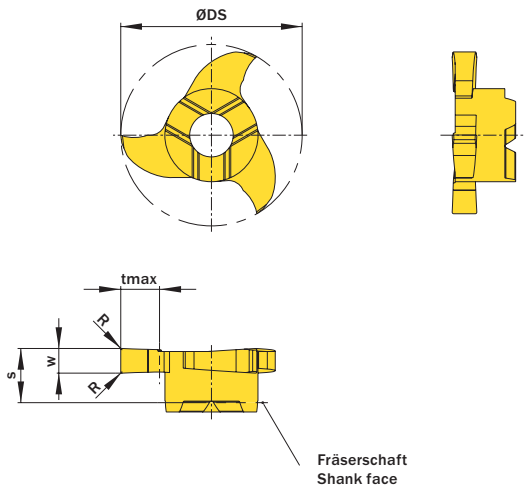


Illustration zeigt beispielhafte Anwendungsmöglichkeit mit ähnlichem Werkzeug.
Image shows exemplary application possibility with similar tool.

Abbildung zeigt / Drawing shows: P12.0160.01 G

w ^{-0,02}	Nuttenbreite Nominal width of groove	R	ØDmin (Min.-Bohrung) ØDmin (min. bore)	Artikelnummer Part number	Webcode www.simtek.com/webcode	Unsere erste Wahl Our first choice	tmax	S	ØDS	ZFP	Connectcode www.simtek.com/ccode
mm	mm	mm	mm			P M K N S	mm	mm	mm		
1,24	1,1	-	12,0	P12.0110.00 G	ACHB	X800 GT42	2,5	3,5	11,7	3	PD06.0
1,44	1,3	0,1	12,0	P12.0130.01 G	AGB6	X800 GT42	2,5	3,5	11,7	3	PD06.0
1,74	1,6	0,1	12,0	P12.0160.01 G	AK06	X800 GT42	2,5	3,5	11,7	3	PD06.0

Bestellbeispiel // Order example: **P12.0110.00 G X800** (X800 = Schneidstoff // Grade)



P12. w, 1/100 mm, 4 Stellen/Digits . R, 1/100 mm, 3 Stellen/Digits Toleranz // Tolerance

Beispielartikelnummer // Example Part number: **P12.0179.030 XG**

simmill AX
simmill PMX
simmill PX
simmill SX
simmill UX
simmill VX
simmill H2
simmill K2
simmill MX
simmill OS
Index

Fräsen von Sicherungsringnuten, innen

Fräsen von Sicherungsringnuten in Bohrungen ab Bohrungsdurchmesser 12,0 mm. Durch hochpositive Schneidengeometrie besonders geeignet für Leichtmetalle.

Circlip Ring Groove Milling, internal

Circlip ring groove milling in bores as of bore diameter 12,0 mm. High positive rake angle for use in light alloys.

Schnittwerte (Start) // Cutting parameters (start)

fzm 0,02 mm	hmax 0,03 mm	Vc Seite/Page 638
-----------------------	------------------------	-----------------------------

Passende Klemmhalter auf Seite // Suitable toolholders on page
485, 486, 487, 488, 489

Vergleichbare Werkzeuge auf Seite // Similar tools on page
463

Bitte Hinweise im Anhang beachten // Please read add. notes

ALL (Seite/Page 645), H01 (Seite/Page 646), H07 (Seite/Page 648)



SP
HM **LM** Legende
Legend **650**

Scan QR-Code Oder besuchen Sie // Or Visit
www.simtek.info/cp/353

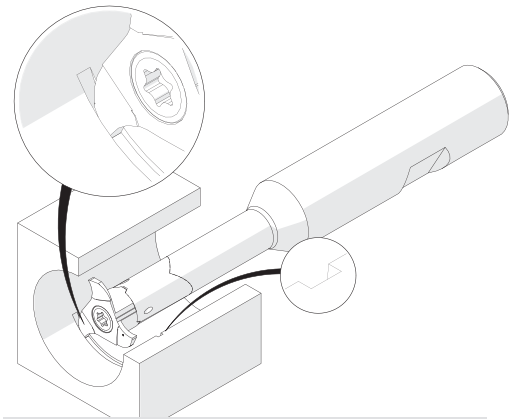
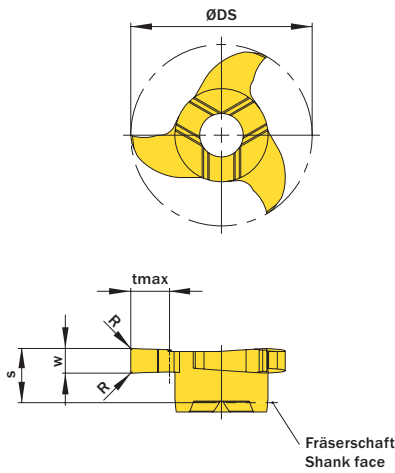


Illustration zeigt beispielhafte Anwendungsmöglichkeit mit ähnlichem Werkzeug.
 Image shows exemplary application possibility with similar tool.

Abbildung zeigt / Drawing shows: P12.0160.41 C

w ^{-0,02}	Nuttenbreite Nominal width of groove	R	ØDmin (Min. Bohrung) ØDmin (min. bore)	Artikelnummer Part number	Webcode www.simtek.com/webcode	Unsere erste Wahl Our first choice	tmax	S	ØDS	ZFP	Connectcode www.simtek.com/ccode	upd
mm	mm	mm	mm			P M K N S	mm	mm	mm			
1,24	1,1	-	12,0	P12.0110.40 C	AKAK	X800 GT42	2,5	3,5	11,7	3	PD06.0	upd
1,44	1,3	0,1	12,0	P12.0130.41 C	AGC3	X800 GT42	2,5	3,5	11,7	3	PD06.0	upd
1,74	1,6	0,1	12,0	P12.0160.41 C	AGNK	X800 GT42	2,5	3,5	11,7	3	PD06.0	upd

Bestellbeispiel // Order example: **P12.0110.40 C GF25** (GF25 = Schneidstoff // Grade)



P12. **w, 1/100 mm, 4 Stellen/Digits** . **R, 1/100 mm, 3 Stellen/Digits** Toleranz // Tolerance **C**
 Beispielartikelnummer // Example Part number: **P12.0179.030 XG C**

Allgemeines Nutfräsen

Nutfräsen gerader Nutformen.
Geeignet ab Bohrungsdurchmesser 10,0 mm.

General Groove Milling

General groove milling.
For use in bores as of minimum bore diameter 10,0 mm.

Schnittwerte (Start) // Cutting parameters (start)		
fzm 0,02 mm	hmax 0,03 mm	Vc Seite/Page 638
Passende Klemmhalter auf Seite // Suitable toolholders on page 485, 486, 487, 488, 489		
Vergleichbare Werkzeuge auf Seite // Similar tools on page 461		
Bitte Hinweise im Anhang beachten // Please read add. notes ALL (Seite/Page 645), H01 (Seite/Page 646), H07 (Seite/Page 648)		

SP Legende
HM Legend

Scan
 Oder besuchen Sie // Or Visit
www.simtek.info/cp/351

Legende Legend **650**

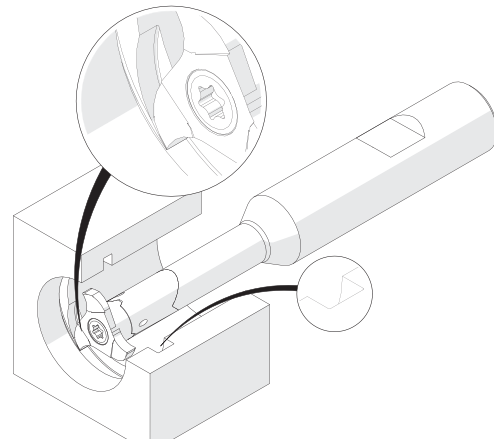
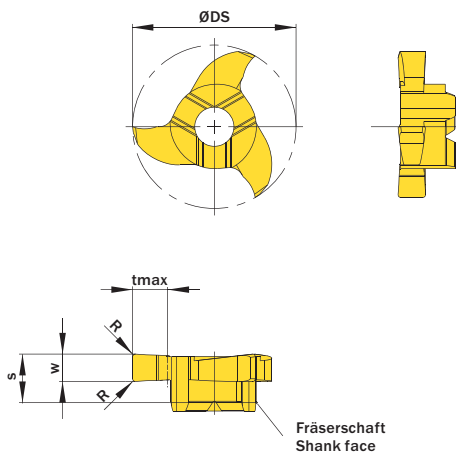


Illustration zeigt beispielhafte Anwendungsmöglichkeit mit ähnlichem Werkzeug.
Image shows exemplary application possibility with similar tool.

Abbildung zeigt / Drawing shows: P12.0250.02 G

w ^{+0,02} mm	Nuttenbreite Nominal width of groove mm	R mm	ØDmin (Min.-Bohrung) ØDmin (min. bore) mm	Artikelnummer Part number	Webcode www.simtek.com/webcode	Unsere erste Wahl Our first choice		tmax mm	S mm	ØDS mm	ZEFP	Connectcode www.simtek.com/ccode
						P M K N S	G T					
1,0	-	0,1	10,0	P10.0100.01 G	AVH5	X800	G142	1,5	3,5	9,7	3	PD06.0
1,5	-	0,2	10,0	P10.0150.02 G	APHM	X800	G142	1,5	3,5	9,7	3	PD06.0
1,575	-	-	10,0	P10.0157.00 G	APT8	X800	G142	1,5	3,5	9,7	3	PD06.0
2,0	-	0,2	10,0	P10.0200.02 G	ABGQ	X800	G142	1,5	3,5	9,7	3	PD06.0
2,5	-	0,2	10,0	P10.0250.02 G	AM11	X800	G142	1,5	3,5	9,7	3	PD06.0

Bestellbeispiel // Order example: **P10.0250.02 G X800** (X800 = Schneidstoff // Grade)



P10. w, 1/100 mm, 4 Stellen/Digits . R, 1/100 mm, 3 Stellen/Digits Toleranz // Tolerance
Beispielartikelnummer // Example Part number: **P10.0179.030 XG**

simmill AX
simmill PMX
simmill PX
simmill SX
simmill UX
simmill VX
simmill H2
simmill K2
simmill MX
simmill OS
Index

Allgemeines Nutfräsen

Nutfräsen gerader Nutformen.
 Geeignet ab Bohrungsdurchmesser 12,0 mm.

General Groove Milling

General groove milling.
 For use in bores as of minimum bore diameter 12,0 mm.

Schnittwerte (Start) // Cutting parameters (start)		
f _{zm} 0,02 mm	h _{max} 0,03 mm	V _c Seite/Page 638

Passende Klemmhalter auf Seite // Suitable toolholders on page
485, 486, 487, 488, 489

Vergleichbare Werkzeuge auf Seite // Similar tools on page
461

Bitte Hinweise im Anhang beachten // Please read add. notes

ALL (Seite/Page 645), H01 (Seite/Page 646), H07 (Seite/Page 648)

SP Legende
HM Legend

Scan
 Oder besuchen Sie // Or Visit
www.simtek.info/cp/366

650

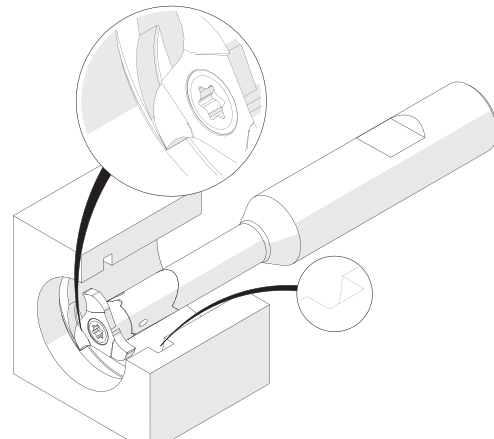
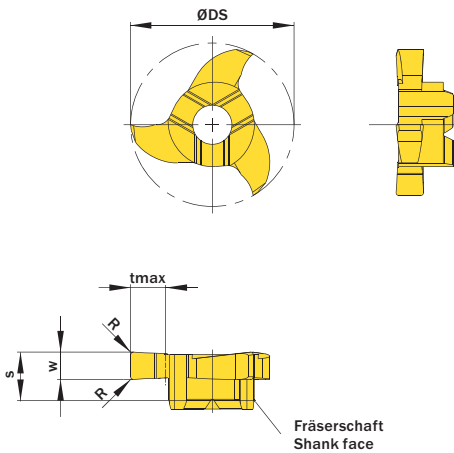


Illustration zeigt beispielhafte Anwendungsmöglichkeit mit ähnlichem Werkzeug.
 Image shows exemplary application possibility with similar tool.

Abbildung zeigt / Drawing shows: P12.0250.02 G

w ^{+0,02}	Nuttenbreite Nominal width of groove	R	ØDmin (Min.-Bohrung) ØDmin (min. bore)	Artikelnummer Part number	Webcode www.simtek.com/webcode	Unsere erste Wahl Our first choice	t _{max}	S	ØDS	ZFP	Connectcode www.simtek.com/ccode
mm	mm	mm	mm			P M K N S	mm	mm	mm		
1,5	-	0,2	12,0	P12.0150.02 G	AM2N	X800 GT42	2,5	3,5	11,7	3	PD06.0
1,575	-	0,2	12,0	P12.0157.02 G	APGW	X800 GT42	2,5	3,5	11,7	3	PD06.0 inch
2,0	-	0,2	12,0	P12.0200.02 G	APVD	X800 GT42	2,5	3,5	11,7	3	PD06.0
2,388	-	0,2	12,0	P12.0239.02 G	ADHQ	X800 GT42	2,5	3,5	11,7	3	PD06.0 new inch
2,5	-	0,2	12,0	P12.0250.02 G	ABHM	X800 GT42	2,5	3,5	11,7	3	PD06.0
3,0	-	0,2	12,0	P12.0300.02 G	A019	X800 GT42	2,5	3,5	11,7	3	PD06.0

Bestellbeispiel // Order example: **P12.0200.02 G X800** (X800 = Schneidstoff // Grade)

simtek individual | P12. w, 1/100 mm, 4 Stellen/Digits . R, 1/100 mm, 3 Stellen/Digits Toleranz // Tolerance
 Beispielartikelnummer // Example Part number: **P12.0179.030 XG**

Allgemeines Nutfräsen

Nutfräsen gerader Nutformen.
 Geeignet ab Bohrungsdurchmesser 12,0 mm.

General Groove Milling

General groove milling.
 For use in bores as of minimum bore diameter 12,0 mm.

Schnittwerte (Start) // Cutting parameters (start)		
f _{zm} 0,02 mm	h _{max} 0,03 mm	V _c Seite/Page 638
Passende Klemmhalter auf Seite // Suitable toolholders on page 485, 486, 487, 488, 489		
Vergleichbare Werkzeuge auf Seite // Similar tools on page 461		
Bitte Hinweise im Anhang beachten // Please read add. notes ALL (Seite/Page 645), H01 (Seite/Page 646), H07 (Seite/Page 648)		

SP Legende
HM Legend

Scan
 Oder besuchen Sie // Or Visit
www.simtek.info/cp/967

Legende
Legend **650**

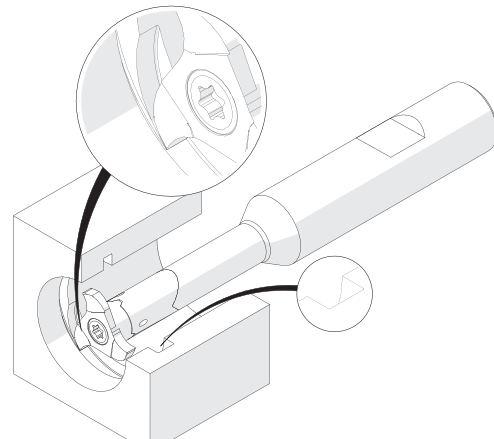
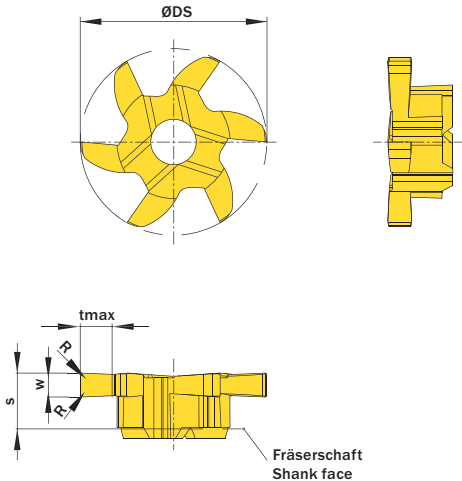


Illustration zeigt beispielhafte Anwendungsmöglichkeit mit ähnlichem Werkzeug.
 Image shows exemplary application possibility with similar tool.

Abbildung zeigt / Drawing shows: P06.0150.02.12 G

w ^{+0,02}	Nuttenbreite Nominal width of groove	R	ØDmin (Min.-Bohrung) ØDmin (min. bore)	Artikelnummer Part number	Webcode www.simtek.com/webcode	Unsere erste Wahl Our first choice	t _{max}	S	ØDS	ZEFP	Connectcode www.simtek.com/ccode
mm	mm	mm	mm			P M K N S	mm	mm	mm		
1,5	-	0,2	12,0	P06.0150.02.12 G	AU7N	X800 GT42	2,0	3,5	11,7	6	PD06.0 PD07.3
2,0	-	0,2	12,0	P06.0200.02.12 G	AU7P	X800 GT42	2,0	3,5	11,7	6	PD06.0 PD07.3

Bestellbeispiel // Order example: **P06.0150.02.12 G X800** (X800 = Schneidstoff // Grade)



P06. w, 1/100 mm, 4 Stellen/Digits . R, 1/100 mm, 3 Stellen/Digits .12 .12 Toleranz // Tolerance

Beispielartikelnummer // Example Part number: **P06.0179.030.12 XG**

simmill AX
simmill PMX
simmill PX
simmill SX
simmill UX
simmill VX
simmill H2
simmill K2
simmill MX
simmill OS
Index

Allgemeines Nutfräsen, für weiche Schnitte

Nutfräsen gerader Nutformen. Weiches Eintauchen in den Werkstückstoff und bessere Oberflächen durch optimierte Schneidengeometrie. Geeignet ab Bohrungsdurchmesser 12,0 mm.

General Groove Milling, for smooth cuts

General groove milling. With a new cutting edge geometry for very smooth cuts and better surface quality. For use in bores as of minimum bore diameter 12,0 mm.

Schnittwerte (Start) // Cutting parameters (start)		
fzm 0,02 mm	hmax 0,03 mm	Vc Seite/Page 638
Passende Klemmhalter auf Seite // Suitable toolholders on page 485, 486, 487, 488, 489		
Vergleichbare Werkzeuge auf Seite // Similar tools on page 461		
Bitte Hinweise im Anhang beachten // Please read add. notes ALL (Seite/Page 645), H07 (Seite/Page 648)		

SP Legende
HM Legend

Scan
 Oder besuchen Sie // Or Visit
www.simtek.info/cp/1121

650

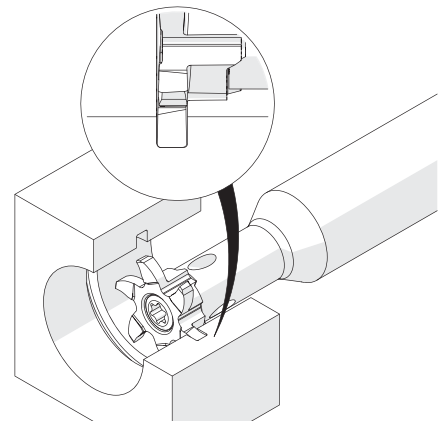
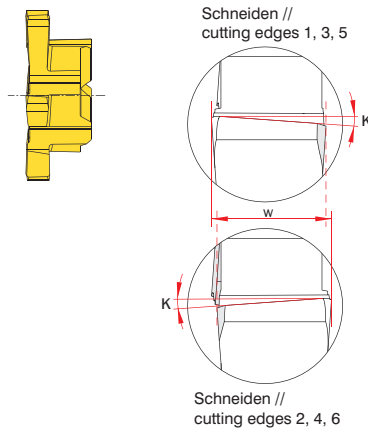
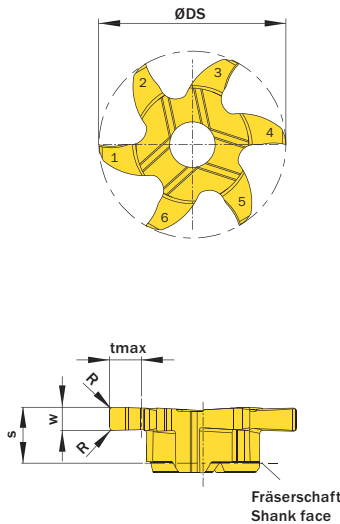


Illustration zeigt beispielhafte Anwendungsmöglichkeit mit ähnlichem Werkzeug.
 Image shows exemplary application possibility with similar tool.

Abbildung zeigt / Drawing shows: P06.0150.020.12 GY

w ^{+0,02} mm	Nuttenbreite Nominal width of groove mm	R mm	ØDmin (Min.-Bohrung) ØDmin (min. bore) mm	Artikelnummer Part number	Webcode www.simtek.com/webcode	Unsere erste Wahl Our first choice P M K N S	tmax mm	S mm	ØDS mm	ZEFP	Connectcode www.simtek.com/ccode
1,5	-	0,2	12,0	P06.0150.020.12 GY	AYF3	X800 GT42	2,0	3,5	11,7	6	PD06.0 PD07.3
2,0	-	0,2	12,0	P06.0200.020.12 GY	AYF4	X800 GT42	2,0	3,5	11,7	6	PD06.0 PD07.3

Bestellbeispiel // Order example: **P06.0150.020.12 GY X800** (X800 = Schneidstoff // Grade)

Allgemeines Nutfräsen in Leichtmetall

Nutfräsen gerader Nutformen in Bohrungen ab Bohrungsdurchmesser 12,0 mm. Durch hochpositive Schneidengeometrie besonders geeignet für Leichtmetalle.

General Groove Milling in light alloys

General groove milling in bores as of bore diameter 12,0 mm. High positive rake angle for use in light alloys.

Schnittwerte (Start) // Cutting parameters (start)		
fzm 0,02 mm	hmax 0,03 mm	Vc Seite/Page 638
Passende Klemmhalter auf Seite // Suitable toolholders on page 485, 486, 487, 488, 489		
Vergleichbare Werkzeuge auf Seite // Similar tools on page 462		
Bitte Hinweise im Anhang beachten // Please read add. notes ALL (Seite/Page 645), H01 (Seite/Page 646), H07 (Seite/Page 648)		

SP

HM

LM

Legende Legend **650**

Scan QR-Code Oder besuchen Sie // Or Visit
www.simtek.info/cp/354

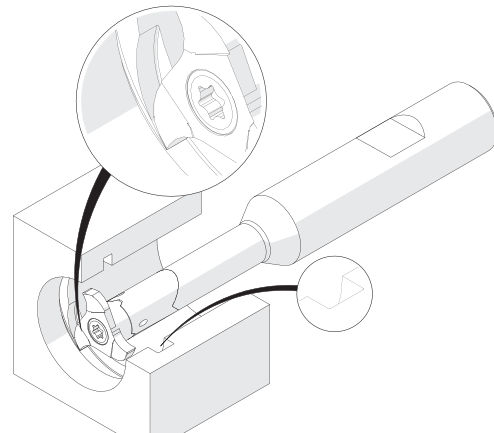
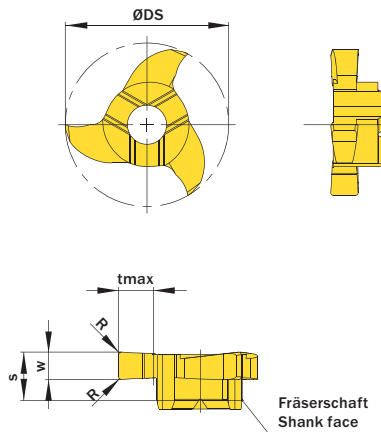


Illustration zeigt beispielhafte Anwendungsmöglichkeit mit ähnlichem Werkzeug. Image shows exemplary application possibility with similar tool.

Abbildung zeigt / Drawing shows: P12.0200.42 C

w ^{+0,02}	Nuttenbreite Nominal width of groove	R	ØDmin (Min.-Bohrung) ØDmin (min. bore)	Artikelnummer Part number	Webcode www.simtek.com/webcode	Unsere erste Wahl Our first choice		tmax	S	ØDS	ZEFP	Connectcode www.simtek.com/ccode
						P M K N S						
mm	mm	mm	mm					mm	mm	mm		
1,5	-	0,2	12,0	P12.0150.42 C	AKVT	X800	GT42	2,5	3,5	11,7	3	PD06.0
2,0	-	0,2	12,0	P12.0200.42 C	AMPQ	X800	GT42	2,5	3,5	11,7	3	PD06.0
2,5	-	0,2	12,0	P12.0250.42 C	AKX9	X800	GT42	2,5	3,5	11,7	3	PD06.0

Bestellbeispiel // Order example: **P12.0250.42 C X800** (X800 = Schneidstoff // Grade)



P12. w, 1/100 mm, 4 Stellen/Digits . R, 1/100 mm, 3 Stellen/Digits Toleranz // Tolerance **C**
Beispielartikelnummer // Example Part number: **P12.0179.030 XG C**

simmill AX
simmill PMX
simmill PX
simmill SX
simmill UX
simmill VX
simmill H2
simmill K2
simmill MX
simmill OS
Index

Fräsen von Vollradiusnuten

Nutfräsen runder Nutformen.
 Geeignet ab Bohrungsdurchmesser 12,0 mm.

Full Radius Groove Milling

Full radius groove milling.
 For use in bores as of minimum bore diameter 12,0 mm.

Schnittwerte (Start) // Cutting parameters (start)		
fzm 0,02 mm	hmax 0,03 mm	Vc Seite/Page 638

Passende Klemmhalter auf Seite // Suitable toolholders on page
485, 486, 487, 488, 489

Vergleichbare Werkzeuge auf Seite // Similar tools on page
465

Bitte Hinweise im Anhang beachten // Please read add. notes

ALL (Seite/Page 645), H01 (Seite/Page 646), H07 (Seite/Page 648)



SP Legende
HM Legend
650

Scan QR-Code Oder besuchen Sie // Or Visit
www.simtek.info/cp/400

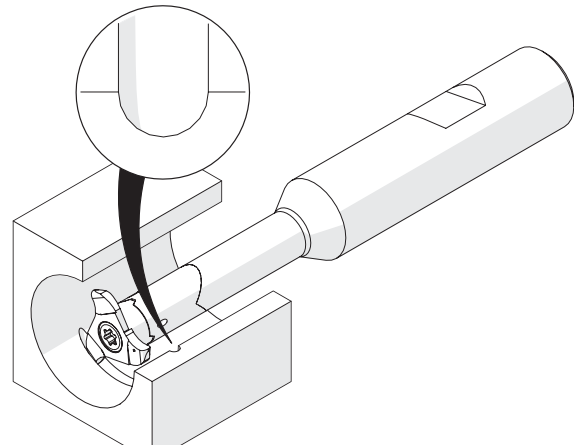
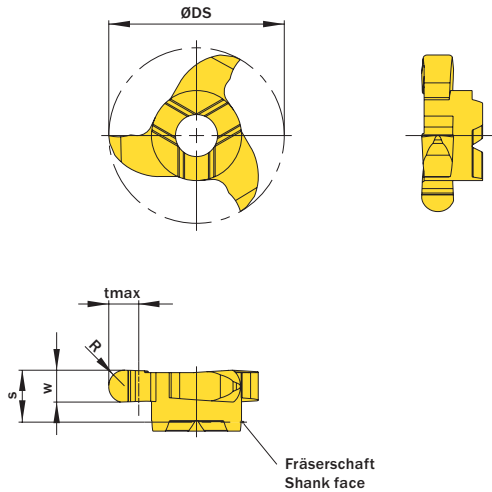


Illustration zeigt beispielhafte Anwendungsmöglichkeit mit ähnlichem Werkzeug.
 Image shows exemplary application possibility with similar tool.

Abbildung zeigt / Drawing shows: P12.0011.22 V

R	w ^{+0,03}	ØDmin (Min. Bohrung) ØDmin (min. bore)	Artikelnummer Part number	Webcode www.simtek.com/webcode	Unsere erste Wahl Our first choice	tmax	S	ØDS	ZEFP	Connectcode www.simtek.com/code	
mm	mm	mm			P M K N S	mm	mm	mm			
0,5	1,0	12,0	P12.0005.10 V	A6WH	X800 GT42	2,5	3,5	11,7	3	PD06.0	new
0,75	1,5	12,0	P12.0007.15 V	A6WK	X800 GT42	2,5	3,5	11,7	3	PD06.0	new
0,787	1,575	12,0	P12.0031.62 V	A3YN	X800 GT42	2,5	3,5	11,7	3	PD06.0	new
1,0	2,0	12,0	P12.0010.20 V	A6WN	X800 GT42	2,5	3,5	11,7	3	PD06.0	new
1,1	2,2	12,0	P12.0011.22 V	AC2H	X800 GT42	2,5	3,5	11,7	3	PD06.0	
1,194	2,388	12,0	P12.0047.94 V	A3C1	X800 GT42	2,5	3,5	11,7	3	PD06.0	new inch
1,5	3,0	12,0	P12.0015.30 V	A6WQ	X800 GT42	2,5	3,5	11,7	3	PD06.0	new

Bestellbeispiel // Order example: **P12.0011.22 V X800** (X800 = Schneidstoff // Grade)

Metrisches ISO-Gewindfräsen, Teilprofil

Ausgelegt als Mehrbereichswerkzeuge. Die angegebene „Steigung (von)“ ist normgerecht. Die „Steigung (bis)“ kann ebenfalls realisiert werden. Vgl. Hinweistexte.

Thread milling, metric ISO-Thread, partial profile

Multi-purpose milling inserts. The given „Pitch (as of)“ is conforming to standards. The „Pitch (up to)“ is possible too at the expense of conformity. Please read additional notes.

Schnittwerte (Start) // Cutting parameters (start)

fzm 0,02 mm	hmax 0,03 mm	Vc Seite/Page 638
-----------------------	------------------------	-----------------------------

Passende Klemmhalter auf Seite // Suitable toolholders on page
485, 486, 487, 488, 489

Vergleichbare Werkzeuge auf Seite // Similar tools on page
466

Bitte Hinweise im Anhang beachten // Please read add. notes
ALL (Seite/Page 645), H03 (Seite/Page 647), H04 (Seite/Page 648), H07 (Seite/Page 648)

SP Legende
HM Legend
650

Scan QR-Code Oder besuchen Sie // Or Visit
www.simtek.info/cp/969

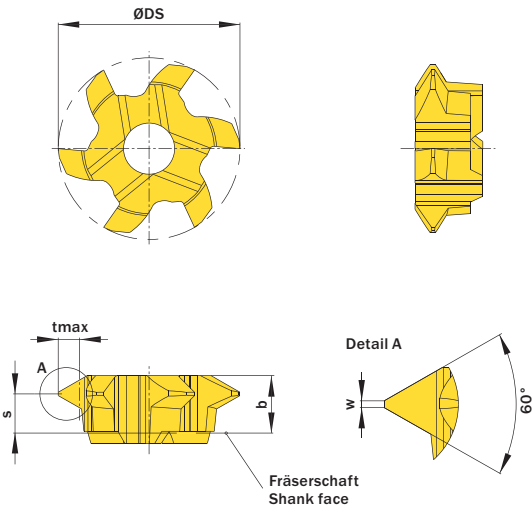


Abbildung zeigt / Drawing shows: P06.0720.01.10 M

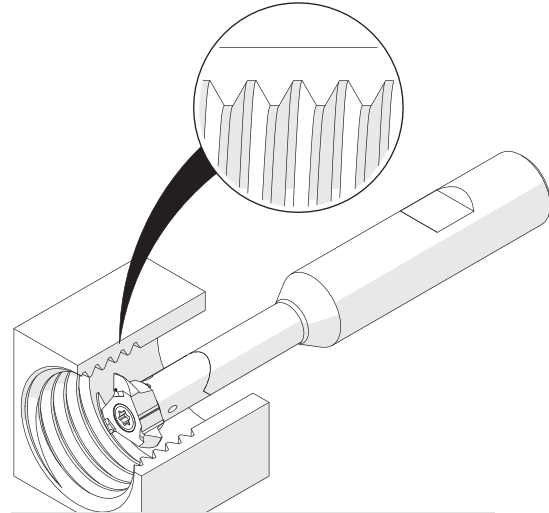


Illustration zeigt beispielhafte Anwendungsmöglichkeit mit ähnlichem Werkzeug. Image shows exemplary application possibility with similar tool.

Ab Gewindgröße As of thread size	Steigung (von) Pitch (as of)	Steigung (bis) Pitch (up to)	Artikelnummer Part number	Webcode www.simtek.com/webcode	Unsere erste Wahl Our first choice		b	S	w	tmax	ØDS	ZEFP	Connectcode www.simtek.com/ccode
					P	M							
M12	1,0	1,75	P06.0510.01.10 M	AU7Q	X800	GT42	3,2	2,4	0,13	1,08	9,8	6	PD06.0 PD07.3
M14	1,0	2,0	P06.0720.01.10 M	AU7S	X800	GT42	3,2	2,2	0,12	1,25	10,1	6	PD06.0 PD07.3
M14	1,0	2,0	P06.0720.01.12 M	AUGB	X800	GT42	3,2	2,7	0,09	1,25	11,7	6	PD06.0 PD07.3
M16	1,5	2,75	P06.0815.01.11 M	AU7T	X800	GT42	3,2	2,0	0,19	1,67	11,0	6	PD06.0 PD07.3
M16	2,0	3,0	P06.2530.01.11 M	AU7U	X800	GT42	3,2	1,9	0,25	1,78	11,1	6	PD06.0 PD07.3

Bestellbeispiel // Order example: **P06.0510.01.10 M X800** (X800 = Schneidstoff // Grade)

Die angegebene GewindgröÙeneignung bezieht sich auf die Startsteigung.
The mentioned thread size „As of thread size“ is based on the starting pitch.

Bitte beachten Sie die zusätzlichen Hinweise zu den Mehrbereichswerkzeugen im Infobereich rechts oben.
Please read the additional notes mentioned in the information area on the top right corner of this page.

Mehr Infos zu den **Mehrbereichswerkzeugen** und deren **GewindgröÙeneignung** finden Sie auf Seite 649

More information about the **multi-purpose thread milling tools** and the **thread size suitability** can be found on page 649

Metrisches ISO-Gewindefräsen, Teilprofil

Ausgelegt als Mehrbereichswerkzeuge. Die angegebene „Steigung (von)“ ist normgerecht. Die „Steigung (bis)“ kann ebenfalls realisiert werden. Vgl. Hinweistexte.

Thread milling, metric ISO-Thread, partial profile

Multi-purpose milling inserts. The given „Pitch (as of)“ is conforming to standards. The „Pitch (up to)“ is possible too at the expense of conformity. Please read additional notes.

Schnittwerte (Start) // Cutting parameters (start)		
fzm 0,02 mm	hmax 0,03 mm	Vc Seite/Page 638

Passende Klemmhalter auf Seite // Suitable toolholders on page
485, 486, 487, 488, 489

Vergleichbare Werkzeuge auf Seite // Similar tools on page
466

Bitte Hinweise im Anhang beachten // Please read add. notes

ALL (Seite/Page 645), H03 (Seite/Page 647), H04 (Seite/Page 648), H07 (Seite/Page 648)



SP Legende
HM Legend
650

Scan QR-Code Oder besuchen Sie // Or Visit
www.simtek.info/cp/357

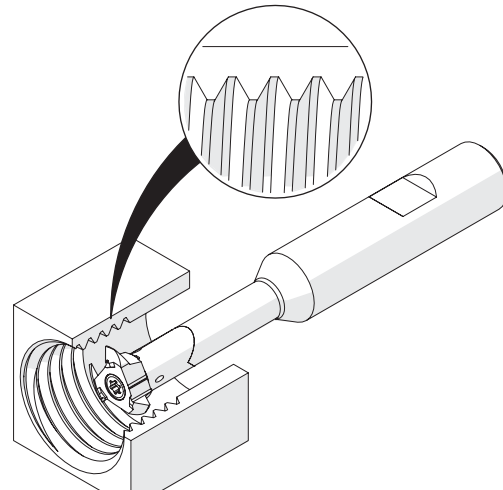
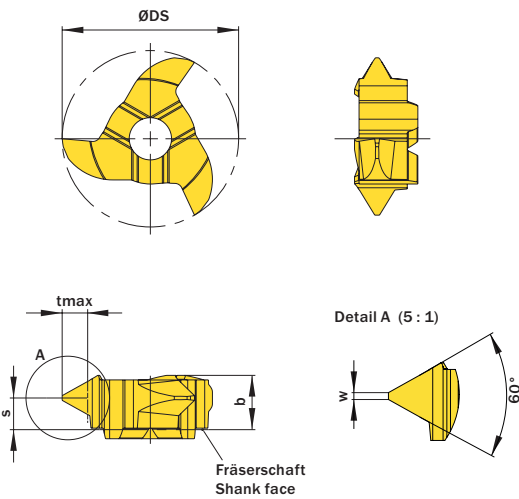


Illustration zeigt beispielhafte Anwendungsmöglichkeit mit ähnlichem Werkzeug.
 Image shows exemplary application possibility with similar tool.

Abbildung zeigt / Drawing shows: P12.2530.01 M

Ab Gewindegroße As of thread size	Steigung (von) Pitch (as of)	Steigung (bis) Pitch (up to)	Artikelnummer Part number	Webcode www.simtek.com/webcode	Unsere erste Wahl Our first choice		b	S	w	tmax	ØDS	ZEFP	Connectcode www.simtek.com/ccode
					P	M							
M14	1,0	1,75	P12.0510.01 M	ANQC	X800	GT42	3,6	2,8	0,13	1,08	11,7	3	PD06.0 PD07.3
M14	1,0	2,0	P12.0720.01 M	ANJZ	X800	GT42	3,6	2,8	0,13	1,25	11,7	3	PD06.0 PD07.3
M16	1,5	2,75	P12.0815.01 M	AC51	X800	GT42	3,6	2,4	0,19	1,67	11,7	3	PD06.0 PD07.3
M16	2,0	3,0	P12.2530.01 M	ADMQ	X800	GT42	3,6	2,2	0,25	1,78	11,7	3	PD06.0 PD07.3

Bestellbeispiel // Order example: **P12.0720.01 M X800** (X800 = Schneidstoff // Grade)

Bitte beachten Sie die zusätzlichen Hinweise zu den Mehrbereichswerkzeugen im Infobereich rechts oben.
 Please read the additional notes mentioned in the information area on the top right corner of this page.

Die angegebene Gewindegroßebezeichnung bezieht sich auf die Startsteigung.
 The mentioned thread size „As of thread size“ is based on the starting pitch.

Mehr Infos zu den **Mehrbereichswerkzeugen** und deren **Gewindegroßebezeichnung** finden Sie auf Seite 649

More information about the **multi-purpose thread milling tools** and the **thread size suitability** can be found on page 649

Metrisches ISO-Gewindefräsen, Vollprofil

Fräsen von metrischen ISO-Gewinden, Vollprofil.

Thread milling, metric ISO-Thread, full profile

Thread milling of metric ISO-thread, full profile.

Schnittwerte (Start) // Cutting parameters (start)		
fzm	hmax	Vc
0,02 mm	0,03 mm	Seite/Page 638

Passende Klemmhalter auf Seite // Suitable toolholders on page
485, 486, 487, 488, 489

Vergleichbare Werkzeuge auf Seite // Similar tools on page
467

Bitte Hinweise im Anhang beachten // Please read add. notes
H06 (Seite/Page 648), H07 (Seite/Page 648)

SP Legende
HM Legend

650

Scan QR-Code Oder besuchen Sie // Or Visit
www.simtek.info/cp/1088

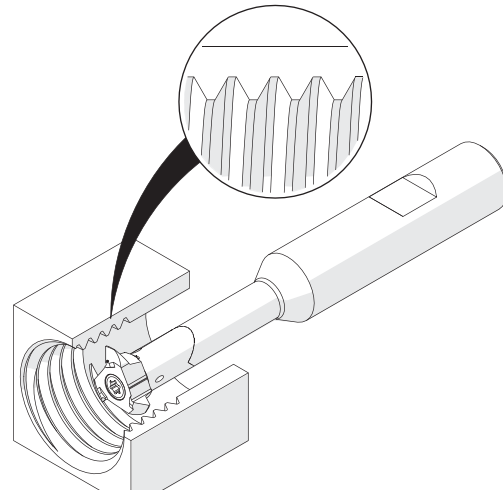
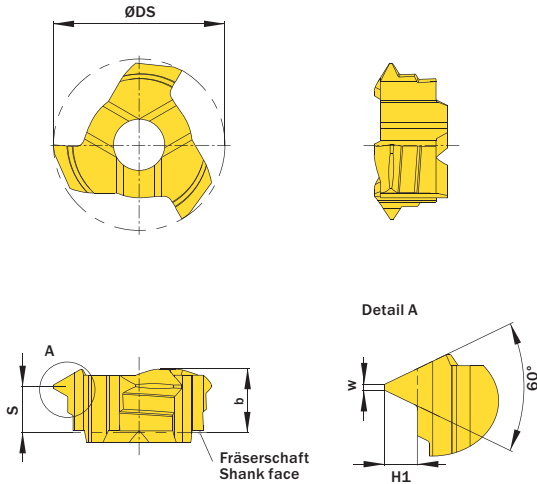


Illustration zeigt beispielhafte Anwendungsmöglichkeit mit ähnlichem Werkzeug.
Image shows exemplary application possibility with similar tool.

Abbildung zeigt / Drawing shows: P10.0815.02 M

Ab Gewindegröße As of thread size	Ab Gewindeneindurchmesser // As of nominal thread diameter	H1	Steigung (von) Pitch (as of)	Artikelnummer Part number	Webcode www.simtek.com/webcode	Unsere erste Wahl Our first choice		ZEFP	b	ØDS	S	w	Connectcode www.simtek.com/ccode
						P	M						
M14	10,82	0,41	0,75	P10.0407.02 M	AXX4	X800	G742	3	3,6	9,7	3,1	0,09	PD06.0 PD07.3 upd
M14	11,56	0,54	1,0	P10.0510.02 M	AXX5	X800	G742	3	3,6	9,7	3,0	0,13	PD06.0 PD07.3 upd
M14	13,32	0,81	1,5	P10.0815.02 M	AXX6	X800	G742	3	3,6	9,7	2,8	0,19	PD06.0 PD07.3 upd
M16	14,28	0,95	1,75	P10.0917.02 M	AXX7	X800	G742	3	3,6	9,7	2,7	0,21	PD06.0 PD07.3 upd
M16	15,3	1,08	2,0	P10.1020.02 M	AXX8	X800	G742	3	3,6	9,7	2,6	0,25	PD06.0 PD07.3 upd
M18	16,3	1,35	2,5	P10.1325.02 M	AXX9	X800	G742	3	3,6	9,7	2,4	0,31	PD06.0 upd

Bestellbeispiel // Order example: **P10.0815.02 M X800** (X800 = Schneidstoff // Grade)

Whitworth-Rohrgewinde, Vollprofil

Fräsen von Whitworth-Rohrgewinden, Vollprofil mit sechs Schneiden und Werkzeug-Schneidkreis ab 9,7 mm.

Whitworth Pipe Thread Milling, full profile

Whitworth pipe thread milling, full profile with six cutting edges and tool diameter as of 9,7 mm.

Schnittwerte (Start) // Cutting parameters (start)

fzm 0,02 mm	hmax 0,03 mm	Vc Seite/Page 638
-----------------------	------------------------	-----------------------------

Passende Klemmhalter auf Seite // Suitable toolholders on page
485, 486, 487, 488, 489

Bitte Hinweise im Anhang beachten // Please read add. notes

ALL (Seite/Page 645), H03 (Seite/Page 647), H05 (Seite/Page 648), H07 (Seite/Page 648)

Scan QR-Code Oder besuchen Sie // Or Visit www.simtek.info/cp/1253

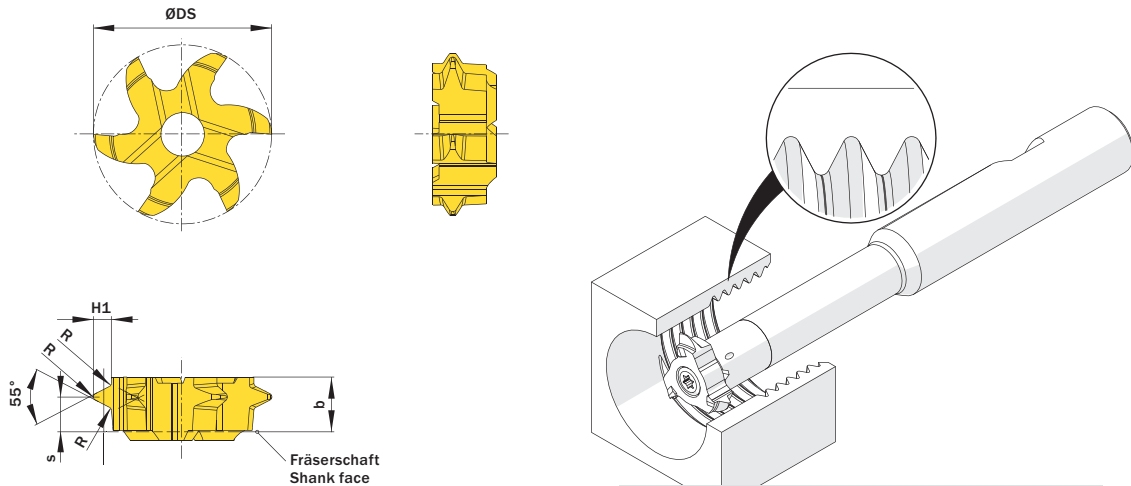


Abbildung zeigt / Drawing shows: P06.1118.14.12 M

Illustration zeigt beispielhafte Anwendungsmöglichkeit mit ähnlichem Werkzeug. Image shows exemplary application possibility with similar tool.

H1	Steigung (von) Pitch (as of)	Gang/Zoll Threads./inch	Artikelnummer Part number	Webcode www.simtek.com/webcode	Unsere erste Wahl Our first choice	R	b	S	ØDS	Ab Gewindegröße As of thread size	Alternativ ab Nenndurchmesser Alternativ as of nominal diameter	ZEFP	Connectcode www.simtek.com/ccode
mm	mm				P M K N S	mm	mm	mm	mm		mm		
0,87	1,34	19	P06.0813.19.10 M	A0Y9	X800 GT42	0,18	3,6	2,5	9,7	G 3/8"	15,1	6	PD06.0 PD07.3
0,87	1,34	19	P06.0813.19.12 M	A09N	X800 GT42	0,18	3,6	2,5	11,7	G 3/8"	15,1	6	PD06.0 PD07.3
1,18	1,81	14	P06.1118.14.12 M	A099	X800 GT42	0,24	3,6	2,3	11,7	G 1/2"	17,5	6	PD06.0 PD07.3

Bestellbeispiel // Order example: **P06.0813.19.12 M X800** (X800 = Schneidstoff // Grade)

Whitworth-Rohrgewinde, Vollprofil

Fräsen von Whitworth-Rohrgewinden,
 Vollprofil mit drei Schneiden und Werkzeug-Schneidkreis von 9,7 mm.

Whitworth Pipe Thread Milling, full profile

Whitworth pipe thread milling,
 full profile with three cutting edges and tool diameter of 9,7 mm.

Schnittwerte (Start) // Cutting parameters (start)		
fzm 0,02 mm	hmax 0,03 mm	Vc Seite/Page 638
Passende Klemmhalter auf Seite // Suitable toolholders on page 485, 486, 487, 488, 489		
Vergleichbare Werkzeuge auf Seite // Similar tools on page 468		
Bitte Hinweise im Anhang beachten // Please read add. notes ALL (Seite/Page 645), H03 (Seite/Page 647), H07 (Seite/Page 648)		

SP Legende
Legend

HM Legende
Legend

Scan
QR-Code

650

Oder besuchen Sie // Or Visit
www.simtek.info/cp/413

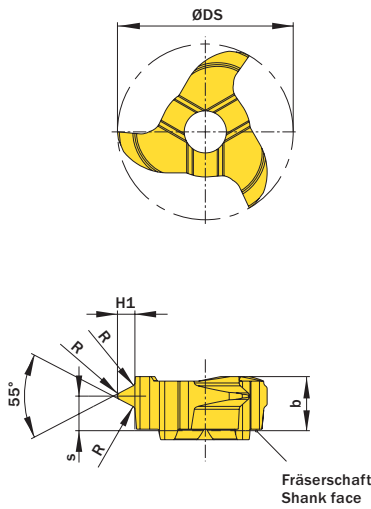


Abbildung zeigt / Drawing shows: P12.1118.14 M

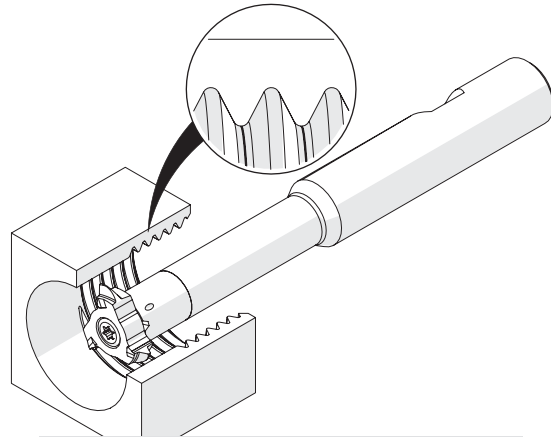
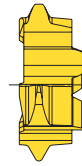


Illustration zeigt beispielhafte Anwendungsmöglichkeit mit ähnlichem Werkzeug.
 Image shows exemplary application possibility with similar tool.

H1	Steigung (von) Pitch (as of)	Gang/Zoll Threads/inch	Artikelnummer Part number	Webcode www.simtek.com/webcode	Unsere erste Wahl Our first choice		R	b	S	ØDS	Ab Gewindegröße As of thread size	Alternativ ab Nenndurchmesser Alternativ as of nominal diameter	ZEFP	Connectcode www.simtek.com/ccode
	mm				mm	P								
0,86	1,34	19	P10.0813.19 M	A1EK	X800	GT42	0,18	3,6	2,5	9,7	G 1/4"	13,0	3	PD06.0 PD07.3
0,86	1,34	19	P12.0813.19 M	AC8H	X800	GT42	0,18	3,6	2,5	11,7	G 3/8"	15,1	3	PD06.0 PD07.3
1,16	1,81	14	P12.1118.14 M	AGX4	X800	GT42	0,25	3,6	2,3	11,7	G 1/2"	17,5	3	PD06.0 PD07.3
1,48	2,31	11	P12.1423.11 M	AC4K	X800	GT42	0,32	3,6	2,0	11,7	G 1"	18,8	3	PD06.0 PD07.3

Bestellbeispiel // Order example: **P12.1118.14 M X800** (X800 = Schneidstoff // Grade)

Fräsen von Fasen

Fasenfräsen beidseitig.
 Geeignet ab Bohrungsdurchmesser 10,0 mm.

Chamfering

Chamfering on both sides.
 For use in bores as of minimum bore diameter 10,0 mm.

Schnittwerte (Start) // Cutting parameters (start)		
fzm	hmax	Vc
0,02 mm	0,03 mm	Seite/Page 638

Passende Klemmhalter auf Seite // Suitable toolholders on page
485, 486, 487, 488, 489

Vergleichbare Werkzeuge auf Seite // Similar tools on page
469

Bitte Hinweise im Anhang beachten // Please read add. notes
ALL (Seite/Page 645), H07 (Seite/Page 648)

SP

Legende

HM

Legende

Scan

QR-Code

650

Oder besuchen Sie // Or Visit
www.simtek.info/cp/971

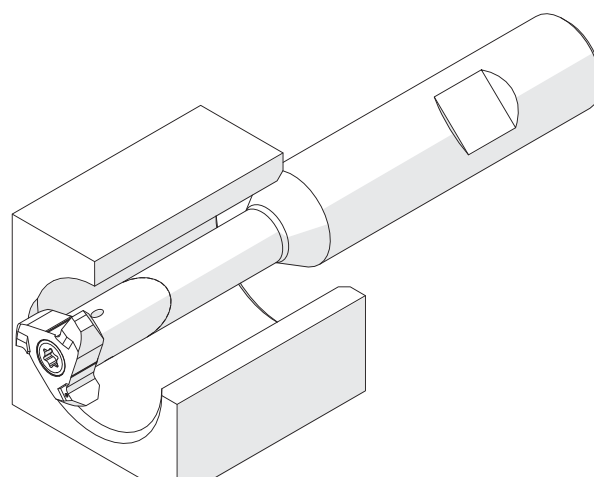
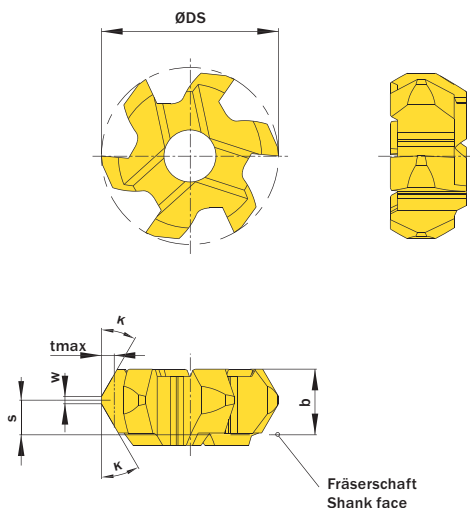


Illustration zeigt beispielhafte Anwendungsmöglichkeit mit ähnlichem Werkzeug.
 Image shows exemplary application possibility with similar tool.

Abbildung zeigt / Drawing shows: P06.3030.02.10 F

K	w	ØDmin (Min. Bohrung) ØDmin (min. bore)	Artikelnummer Part number	Webcode www.simtek.com/webcode	Unsere erste Wahl Our first choice		b	S	tmax	ØDS	ZEFP	Connectcode www.simtek.com/ccode
					P	M						
15°	0,2	10,0	P06.1515.02.10 F	AU7W	X800	GT42	3,6	1,9	0,35	9,7	6	PD06.0 PD07.3
20°	0,2	10,0	P06.2020.02.10 F	AU7X	X800	GT42	3,6	1,9	0,45	9,7	6	PD06.0 PD07.3
30°	0,2	10,0	P06.3030.02.10 F	AU7Y	X800	GT42	3,6	1,9	0,7	9,7	6	PD06.0 PD07.3
45°	0,2	10,0	P06.4545.02.10 F	AU7V	X800	GT42	3,6	1,9	1,2	9,7	6	PD06.0 PD07.3

Bestellbeispiel // Order example: **P06.4545.02.10 F X800** (X800 = Schneidstoff // Grade)

Fräsen von Fasen

Fasenfräsen beidseitig.
 Geeignet ab Bohrungsdurchmesser 9,6 mm.

Chamfering

Chamfering on both sides.
 For use in bores as of minimum bore diameter 9,6 mm.

Schnittwerte (Start) // Cutting parameters (start)		
fzm 0,02 mm	hmax 0,03 mm	Vc Seite/Page 638
Passende Klemmhalter auf Seite // Suitable toolholders on page		
485, 486, 487, 488, 489		
Vergleichbare Werkzeuge auf Seite // Similar tools on page		
469		
Bitte Hinweise im Anhang beachten // Please read add. notes		
ALL (Seite/Page 645), H07 (Seite/Page 648)		

SP

Legende

HM

Legend

Scan QR-Code

Oder besuchen Sie // Or Visit
www.simtek.info/cp/404

650

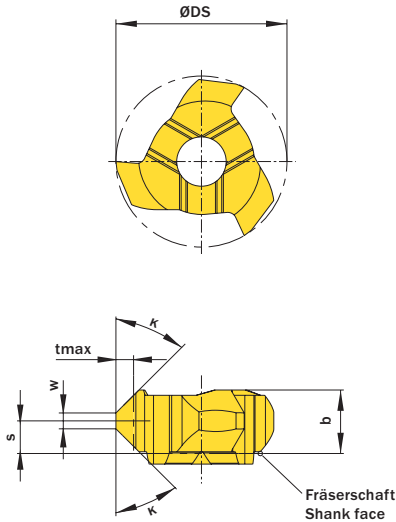


Abbildung zeigt / Drawing shows: P10.4545.35 F

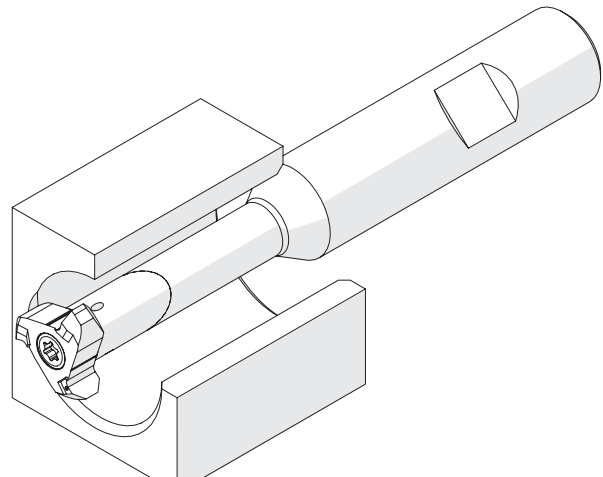


Illustration zeigt beispielhafte Anwendungsmöglichkeit mit ähnlichem Werkzeug.
 Image shows exemplary application possibility with similar tool.

K	w mm	ØDmin (Min. Bohrung) ØDmin (min. bore) mm	Artikelnummer Part number	Webcode www.simtek.com/webcode	Unsere erste Wahl Our first choice		b mm	s mm	tmax mm	ØDS mm	ZEFP	Connectcode www.simtek.com/ccode
					P	M						
45°	0,2	9,6	P09.4545.02 F	AA0U	X800	GT42	3,37	1,7	1,4	9,3	3	PD06.0
45°	0,9	10,0	P10.4545.35 F	AJHX	X800	GT42	3,5	1,8	1,0	9,7	3	PD06.0 PD07.3
45°	1,2	12,0	P12.4545.35 F	ABG0	X800	GT42	3,5	1,8	0,8	11,7	3	PD06.0 PD07.3

Bestellbeispiel // Order example: **P09.4545.02 F X800** (X800 = Schneidstoff // Grade)

simmill AX

simmill PMX

simmill PX

simmill SX

simmill UX

simmill VX

simmill H2

simmill K2

simmill MX

simmill OS

Index

Fräsen von Schwalbenschwanznuten

Schneidkreisdurchmesser ab 11,7 mm mit 6 Schneiden.

Dovetail milling

Tool diameter of 11,7 mm with 6 cutting edges.

Schnittwerte (Start) // Cutting parameters (start)		
fzm	hmax	Vc
0,02 mm	0,03 mm	Seite/Page 638

Passende Klemmhalter auf Seite // Suitable toolholders on page
485, 486, 487, 488, 489

Bitte Hinweise im Anhang beachten // Please read add. notes
ALL (Seite/Page 645), H07 (Seite/Page 648)

SP

Legende

HM

Legende

Scan QR-Code

650

Oder besuchen Sie // Or Visit
www.simtek.info/cp/1371

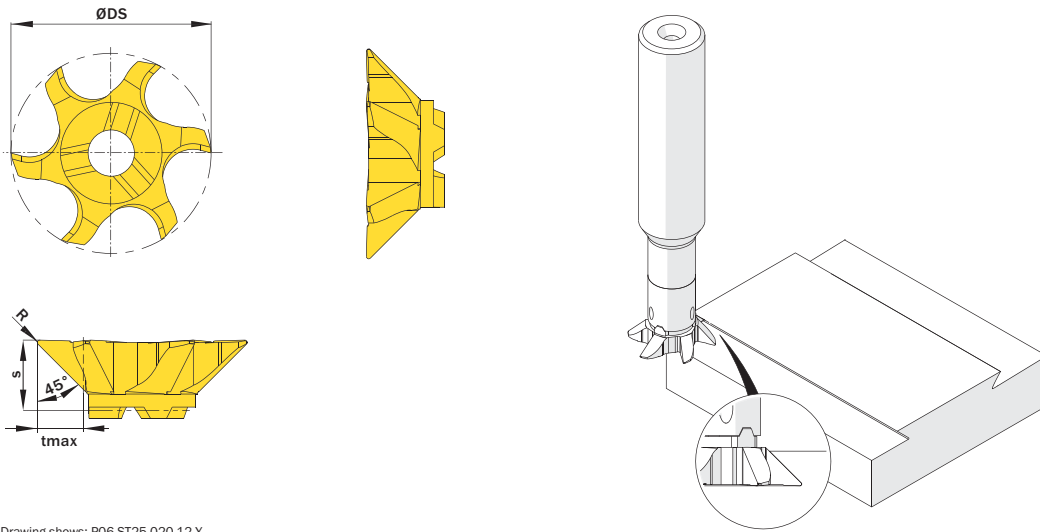


Abbildung zeigt / Drawing shows: P06.ST25.020.12 Y

tmax	R	ØDmin (Min. Bohrung) ØDmin (min. bore)	Artikelnummer Part number	Webcode www.simtek.com/webcode	Unsere erste Wahl Our first choice	S	ØDS	ZEFP	Connectcode www.simtek.com/ccode
mm	mm	mm			P M K N S	mm	mm		PD06.0 PD07.3
2,0	0,2	12,0	P06.ST25.020.12 Y	A03H	X800 GT42	2,0	11,7	6	PD06.0 PD07.3 new

Bestellbeispiel // Order example: **P06.ST25.020.12 Y X800** (X800 = Schneidstoff // Grade)



Ab Seite // As of page

461

Anwendungsübersicht
Application overview

simmill AX

simmill PMX

simmill PX

simmill SX

simmill UX

simmill VX

simmill H2

simmill K2

simmill MX

simmill OS

Index

507

Fräserschaft, zylindrisch (vgl. DIN 6535 HA)

Schwingungsgedämpfte Hartmetall-Ausführung mit innerer Kühlmittelzufuhr und Aufnahme nach DIN 6535 HA.

Milling Cutter Shank, cylindrical (DIN 6535 HA)

Anti-vibration solid carbide type with through coolant and shank according to DIN 6535 HA.

Anzugsmoment (Schraube) // Tightening torque (screw)

3,5 Nm

Vergleichbare Werkzeuge auf Seite // Similar tools on page
473

Bitte Hinweise im Anhang beachten // Please read add. notes

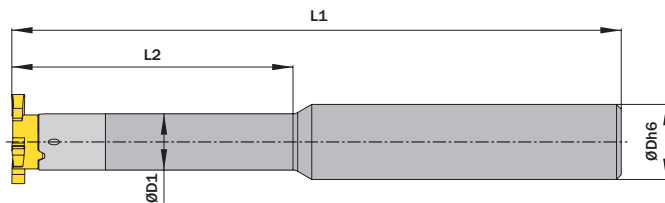
ALL (Seite/Page 645)



Legende
Legend **650**



Oder besuchen Sie // Or Visit
www.simtek.info/cp/389



ØDh6	ØD1	L2	Artikelnummer Part number	Webcode www.simtek.com/webcode	L1	Schraube Screw	Schraubenschlüssel Screw driver	Connectcode www.simtek.com/code
mm	mm	mm			mm			
▼ ØDh6 = 12,0 mm								
12,0	8,0	29,0	S14.1208.29 A HM	AM5T	95,0	S M3,5x10 T10F	T10F	SD08.0
12,0	8,0	42,0	S14.1208.42 A HM	AAD5	110,0	S M3,5x10 T10F	T10F	SD08.0
12,0	8,0	56,0	S14.1208.56 A HM	ADVQ	120,0	S M3,5x10 T10F	T10F	SD08.0
12,0	9,5	42,0	S14.1209.42 A HM	AG09	110,0	S M3,5x10 T10F	T10F	SD09.5
▼ ØDh6 = 12,7 mm								
12,7	8,0	29,0	S14.0.500.08.29 A HM	ACPS	95,0	S M3,5x10 T10F	T10F	SD08.0 <small>inch</small>
12,7	8,0	42,0	S14.0.500.08.42 A HM	ABPC	110,0	S M3,5x10 T10F	T10F	SD08.0 <small>inch</small>
12,7	8,0	56,0	S14.0.500.08.56 A HM	AMWV	120,0	S M3,5x10 T10F	T10F	SD08.0 <small>inch</small>
12,7	9,5	42,0	S14.0.500.09.42 A HM	AJQS	110,0	S M3,5x10 T10F	T10F	SD09.5 <small>inch</small>
▼ ØDh6 = 15,875 mm								
15,875	9,5	33,0	S14.0.625.09.33 A HM	AH1U	110,0	S M3,5x10 T10F	T10F	SD09.5 <small>inch</small>
▼ ØDh6 = 16,0 mm								
16,0	9,5	33,0	S14.1609.33 A HM	AJTB	110,0	S M3,5x10 T10F	T10F	SD09.5

Bestellbeispiel // Order example: **S14.1208.29 A HM**

Fräserschaft, zylindrisch (vgl. DIN 1835 A)

Stahl-Ausführung mit Aufnahme nach DIN 1835 A.

Milling Cutter Shank, cylindrical (DIN 1835 A)

Steel type with shank according to DIN 1835 A.

Anzugsmoment (Schraube) // Tightening torque (screw)

3,5 Nm

Vergleichbare Werkzeuge auf Seite // Similar tools on page
474

Bitte Hinweise im Anhang beachten // Please read add. notes
ALL (Seite/Page 645)



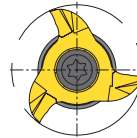
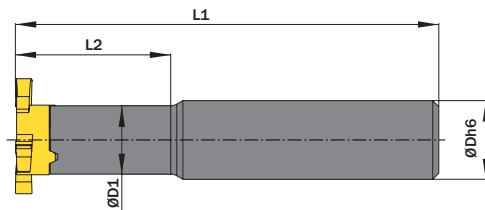
TW
ST

Legende
Legend **650**



Scan
QR-Code

Oder besuchen Sie // Or Visit
www.simtek.info/cp/392



ØDh6 mm	ØD1 mm	L2 mm	Artikelnummer Part number	Webcode www.simtek.com/webcode	Mit Kühlmittelzufuhr With through coolant supply	L1 mm	Schraube Screw	Schraubenschlüssel Screw driver	Connectcode www.simtek.com/code
▼ ØDh6 = 10,0 mm									
10,0	8,0	17,0	S14.1008.17 A ST	AAKP	Nein / No	60,0	SM3,5x10 T10F	T10F	SD08.0
▼ ØDh6 = 13,0 mm									
13,0	8,0	25,0	S14.1308.25 A ST	AE8U	Nein / No	70,0	SM3,5x10 T10F	T10F	SD08.0
▼ ØDh6 = 15,875 mm									
15,875	8,0	16,0	S14.0.625.08.16 A ST	ACT3	Ja / Yes	80,0	SM3,5x10 T10F	T10F	SD08.0 Inch
▼ ØDh6 = 16,0 mm									
16,0	8,0	16,0	S14.1608.16 A ST	AABY	Ja / Yes	80,0	SM3,5x10 T10F	T10F	SD08.0

Bestellbeispiel // Order example: **S14.1608.16 A ST**

Fräserschaft, Weldon (vgl. DIN 6535 HB)

Schwingungsgedämpfte Hartmetall-Ausführung mit innerer Kühlmittelzufuhr und Aufnahme nach DIN 6535 HB.

Milling Cutter Shank, Weldon (DIN 6535 HB)

Anti-vibration solid carbide type with through coolant and shank according to DIN 6535 HB.

Anzugsmoment (Schraube) // Tightening torque (screw)

3,5 Nm

Vergleichbare Werkzeuge auf Seite // Similar tools on page
475

Bitte Hinweise im Anhang beachten // Please read add. notes

ALL (Seite/Page 645)

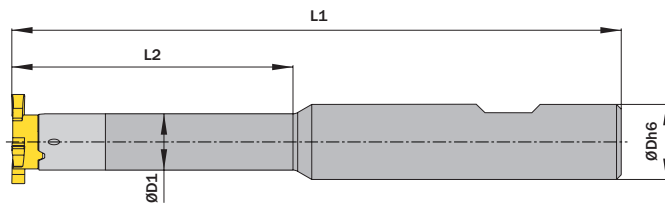


Legende
Legend **650**



Scan
QR-Code

Oder besuchen Sie // Or Visit
www.simtek.info/cp/390



ØDh6	ØD1	L2	Artikelnummer Part number	Webcode www.simtek.com/webcode	L1	Schraube Screw	Schraubenschlüssel Screw driver	Connectcode www.simtek.com/code	
mm	mm	mm			mm				
▼ ØDh6 = 12,0 mm									
12,0	8,0	29,0	S14.1208.29 B HM	AG22	95,0	SM3,5x10 T10F	T10F	SD08.0	
12,0	8,0	42,0	S14.1208.42 B HM	ACPK	110,0	SM3,5x10 T10F	T10F	SD08.0	
12,0	8,0	56,0	S14.1208.56 B HM	AC9E	120,0	SM3,5x10 T10F	T10F	SD08.0	
12,0	9,5	42,0	S14.1209.42 B HM	AAKT	110,0	SM3,5x10 T10F	T10F	SD09.5	
▼ ØDh6 = 12,7 mm									
12,7	8,0	29,0	S14.0.500.08.29 B HM	AMUB	95,0	SM3,5x10 T10F	T10F	SD08.0 <small>Inch</small>	
12,7	8,0	42,0	S14.0.500.08.42 B HM	AJSC	110,0	SM3,5x10 T10F	T10F	SD08.0 <small>Inch</small>	
12,7	8,0	56,0	S14.0.500.08.56 B HM	AMKD	120,0	SM3,5x10 T10F	T10F	SD08.0 <small>Inch</small>	
12,7	9,5	42,0	S14.0.500.09.42 B HM	ABSC	110,0	SM3,5x10 T10F	T10F	SD09.5 <small>Inch</small>	
▼ ØDh6 = 15,875 mm									
15,875	9,5	33,0	S14.0.625.09.33 B HM	AMHU	110,0	SM3,5x10 T10F	T10F	SD09.5 <small>Inch</small>	
▼ ØDh6 = 16,0 mm									
16,0	9,5	33,0	S14.1609.33 B HM	AH8J	110,0	SM3,5x10 T10F	T10F	SD09.5	

Bestellbeispiel // Order example: **S14.1208.29 B HM**

Fräserschaft, Weldon (vgl. DIN 1835 B)

Stahl-Ausführung mit innerer
Kühlmittelzufuhr und Aufnahme nach DIN 1835 B.

Milling Cutter Shank, Weldon (DIN 1835 B)

Steel type with through coolant and shank according to DIN 1835 B.

Anzugsmoment (Schraube) // Tightening torque (screw)

3,5 Nm

Vergleichbare Werkzeuge auf Seite // Similar tools on page
476

Bitte Hinweise im Anhang beachten // Please read add. notes
ALL (Seite/Page 645)



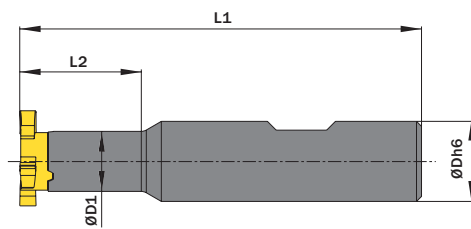
Legende
Legend

650



Scan
QR-Code

Oder besuchen Sie // Or Visit
www.simtek.info/cp/421



ØDh6 mm	ØD1 mm	L2 mm	Artikelnummer Part number	Webcode www.simtek.com/webcode	L1 mm	Schraube Screw	Schraubenschlüssel Screw driver	Connectcode www.simtek.com/code	
▼ ØDh6 = 15,875 mm									
15,875	8,0	16,0	S14.0.625.08.16 B ST	AF5E	80,0	S M3,5x10 T10F	T10F	SD08.0	
▼ ØDh6 = 16,0 mm									
16,0	8,0	16,0	S14.1608.16 B ST	AH01	80,0	S M3,5x10 T10F	T10F	SD08.0	

Bestellbeispiel // Order example: **S14.1608.16 B ST**

simmill AX

simmill PMX

simmill PX

simmill SX

simmill UX

simmill VX

simmill H2

simmill K2

simmill MX

simmill OS

Index

Fräserschaft, für Spannzangenfutter (DIN 6499)

Für Spannzangenfutter nach DIN6499-A.

Milling cutter shank, for collet chucks (DIN6499)

For collet chucks according to DIN6499-A.

Anzugsmoment (Schraube) // Tightening torque (screw)

3,5 Nm

Vergleichbare Werkzeuge auf Seite // Similar tools on page
472

Bitte Hinweise im Anhang beachten // Please read add. notes

ALL (Seite/Page 645)



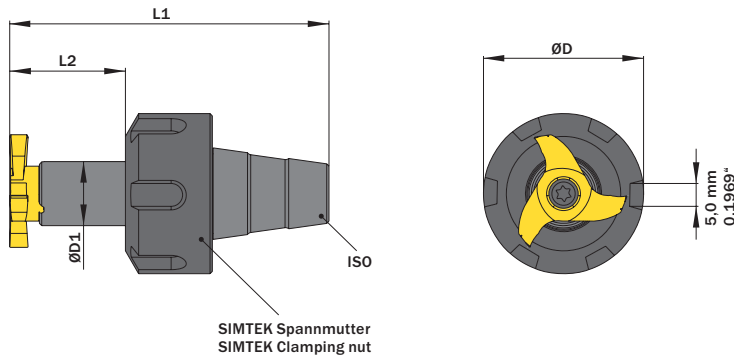
Legende
Legend

650



Scan
QR-Code

Oder besuchen Sie // Or Visit
www.simtek.info/cp/454



Fräserschaft ist nur mit passender Spannmutter verfügbar.
Spannmutter ist auch einzeln als Ersatzteil verfügbar.
Milling cutter shank is only available together with clamping nut.
Clamping nut is available as a spare part.

Für Spannzange For collet chuck	ØD1	L2	Artikelnummer Part number	Webcode www.simtek.com/webcode	Spannmutter Clamping nut	Gewinde Spannmutter Thread clamping nut	ØD	L1	Schraube Screw	Schraubenschlüssel Screw driver	Connectcode www.simtek.com/code
	mm	mm					mm	mm			
ER11	8,0	16,0	S14.ER11.08.16	AJE5	SER11.12.19	M14x0,75	19,0	36,3	SM3,5x10 T10F	T10F	SD08.0
ER11	8,0	16,0	S14.ER11.08.16.B	AVMQ	SER11.12.16	M13x0,75	16,0	36,3	SM3,5x10 T10F	T10F	SD08.0
ER16	8,0	22,0	S14.ER16.08.22	ACTZ	SER16.18.32	M22x1,5	32,0	52,0	SM3,5x10 T10F	T10F	SD08.0
ER16	8,0	22,0	S14.ER16.08.22.B	AVMT	SER16.18.22	M19x1,0	22,0	52,0	SM3,5x10 T10F	T10F	SD08.0
ER16	8,0	22,0	S14.ER16.08.22.C	AVMU	SER16.18.25	M19x1,0	25,0	52,0	SM3,5x10 T10F	T10F	SD08.0
ER20	8,0	22,0	S14.ER20.08.22	AFPE	SER20.19.35	M25x1,5	35,0	56,5	SM3,5x10 T10F	T10F	SD08.0
ER20	8,0	22,0	S14.ER20.08.22.B	AVMZ	SER20.19.28	M24x1,0	28,0	56,5	SM3,5x10 T10F	T10F	SD08.0

Bestellbeispiel // Order example: **S14.ER16.08.22**

Allgemeines Nutfräsen

Nutfräsen gerader Nutformen.
 Geeignet ab Bohrungsdurchmesser 14,0 mm.

General Groove Milling

General groove milling.
 For use in bores as of minimum bore diameter 14,0 mm.

Schnittwerte (Start) // Cutting parameters (start)		
f _{zm} 0,02 mm	h _{max} 0,03 mm	V _c Seite/Page 638
Passende Klemmhalter auf Seite // Suitable toolholders on page 508, 509, 510, 511, 512		
Vergleichbare Werkzeuge auf Seite // Similar tools on page 461		
Bitte Hinweise im Anhang beachten // Please read add. notes ALL (Seite/Page 645), H01 (Seite/Page 646), H07 (Seite/Page 648)		

SP Legende
HM Legend **650**

Scan QR-Code Oder besuchen Sie // Or Visit
www.simtek.info/cp/359

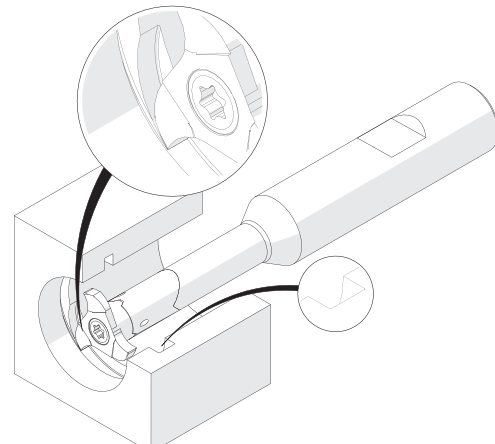
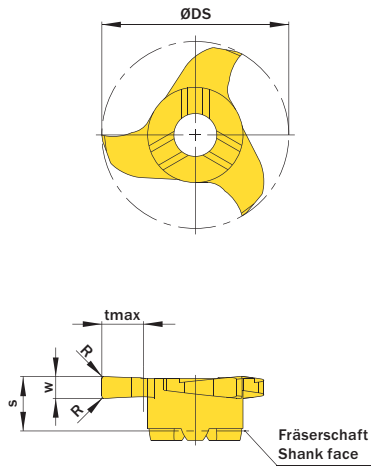


Illustration zeigt beispielhafte Anwendungsmöglichkeit mit ähnlichem Werkzeug.
 Image shows exemplary application possibility with similar tool.

Abbildung zeigt / Drawing shows: S16.0200.02 G

w ^{+0,02} mm	Nuttenbreite Nominal width of groove mm	R mm	ØDmin (Min.-Bohrung) ØDmin (min. bore) mm	Artikelnummer Part number	Webcode www.simtek.com/webcode	Unsere erste Wahl Our first choice		tmax mm	S mm	ØDS mm	ZEFP	Connectcode www.simtek.com/code
						P M K N S	G T					
1,04	-	-	14,0	S14.0100.00 G	AVH6	X800	GT42	2,5	4,5	13,7	3	SD08.0
1,0	-	0,1	14,0	S14.0100.01 G	ADNZ	X800	GT42	2,5	4,5	13,7	3	SD08.0
1,168	-	-	14,0	S14.0117.00 G	AB4V	X800	GT42	2,5	4,5	13,7	3	SD08.0
1,422	-	-	14,0	S14.0142.00 G	AAD1	X800	GT42	2,5	4,5	13,7	3	SD08.0
1,5	-	0,2	14,0	S14.0150.02 G	AGJ3	X800	GT42	2,5	4,5	13,7	3	SD08.0
1,575	-	0,2	14,0	S14.0157.02 G	AHP3	X800	GT42	2,5	4,5	13,7	3	SD08.0
2,0	-	0,2	14,0	S14.0200.02 G	AMG7	X800	GT42	2,5	4,5	13,7	3	SD08.0
2,388	-	0,2	14,0	S14.0239.02 G	APC6	X800	GT42	2,5	4,5	13,7	3	SD08.0
2,5	-	0,2	14,0	S14.0250.02 G	ANZT	X800	GT42	2,5	4,5	13,7	3	SD08.0

Bestellbeispiel // Order example: **S14.0250.02 G X800** (X800 = Schneidstoff // Grade)



S14. **w, 1/100 mm, 4 Stellen/Digits** . **R, 1/100 mm, 3 Stellen/Digits** **Toleranz // Tolerance**
 Beispielartikelnummer // Example Part number: **S14.0179.030 XG**

simmill AX
 simmill PMX
 simmill PX
 simmill SX
 simmill UX
 simmill VX
 simmill H2
 simmill K2
 simmill MX
 simmill OS
 Index

Allgemeines Nutfräsen

Nutfräsen gerader Nutformen.
 Geeignet ab Bohrungsdurchmesser 16,0 mm.

General Groove Milling

General groove milling.
 For use in bores as of minimum bore diameter 16,0 mm.

Schnittwerte (Start) // Cutting parameters (start)		
fzm 0,02 mm	hmax 0,03 mm	Vc Seite/Page 638

Passende Klemmhalter auf Seite // Suitable toolholders on page
508, 509, 510, 511, 512

Vergleichbare Werkzeuge auf Seite // Similar tools on page
461

Bitte Hinweise im Anhang beachten // Please read add. notes

ALL (Seite/Page 645), H01 (Seite/Page 646), H07 (Seite/Page 648)



SP Legende
HM Legend
650

Scan QR-Code Oder besuchen Sie // Or Visit
www.simtek.info/cp/368

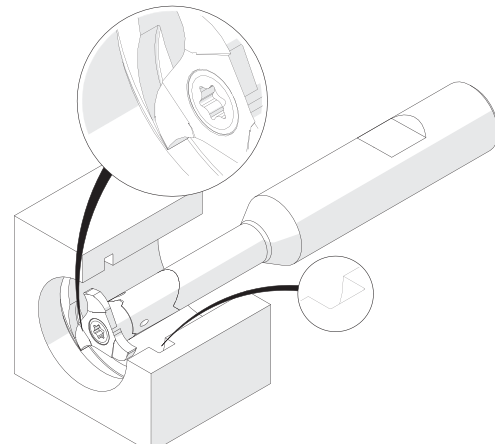
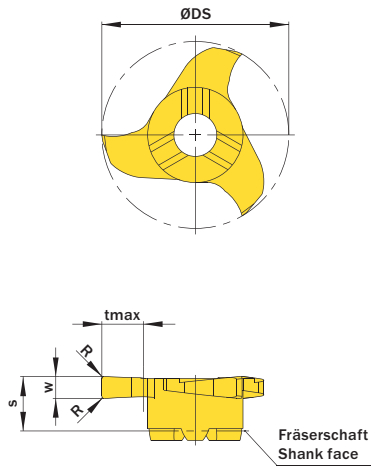


Illustration zeigt beispielhafte Anwendungsmöglichkeit mit ähnlichem Werkzeug.
 Image shows exemplary application possibility with similar tool.

Abbildung zeigt / Drawing shows: S16.0200.02 G

w ^{+0,02}	Nuttenbreite Nominal width of groove	R	ØDmin (Min. Bohrung) ØDmin (min. bore)	Artikelnummer Part number	Webcode www.simtek.com/webcode	Unsere erste Wahl Our first choice	tmax	S	ØDS	ZEFP	Connectcode www.simtek.com/ccode	
mm	mm	mm	mm			P M K N S	mm	mm	mm			
1,168	-	-	16,0	S16.0117.00 G	ABPS	X800 GT42	3,5	4,5	15,7	3	SD08.0	inch
1,422	-	-	16,0	S16.0142.00 G	AFV8	X800 GT42	3,5	4,5	15,7	3	SD08.0	inch
1,5	-	0,2	16,0	S16.0150.02 G	AMBC	X800 GT42	3,5	4,5	15,7	3	SD08.0	
1,575	-	0,2	16,0	S16.0157.02 G	ACMX	X800 GT42	3,5	4,5	15,7	3	SD08.0	inch
2,0	-	0,2	16,0	S16.0200.02 G	ABYC	X800 GT42	3,5	4,5	15,7	3	SD08.0	
2,388	-	0,2	16,0	S16.0239.02 G	AFN8	X800 GT42	3,5	4,5	15,7	3	SD08.0	inch
2,5	-	0,2	16,0	S16.0250.02 G	AF11	X800 GT42	3,5	4,5	15,7	3	SD08.0	inch
3,175	-	0,2	16,0	S16.0318.02 G	A4SB	X800 GT42	3,5	4,5	15,7	3	SD08.0	new inch

Bestellbeispiel // Order example: **S16.0200.02 G X800** (X800 = Schneidstoff // Grade)



S16. **w, 1/100 mm, 4 Stellen/Digits** . **R, 1/100 mm, 3 Stellen/Digits** **Toleranz // Tolerance**
 Beispielartikelnummer // Example Part number: **S16.0179.030 XG**

Allgemeines Nutfräsen

Nutfräsen gerader Nutformen.
 Geeignet ab Bohrungsdurchmesser 16,0 mm.

General Groove Milling

General groove milling.
 For use in bores as of minimum bore diameter 16,0 mm.

Schnittwerte (Start) // Cutting parameters (start)		
fzm 0,02 mm	hmax 0,03 mm	Vc Seite/Page 638
Passende Klemmhalter auf Seite // Suitable toolholders on page 508, 509, 510, 511, 512		
Vergleichbare Werkzeuge auf Seite // Similar tools on page 461		
Bitte Hinweise im Anhang beachten // Please read add. notes ALL (Seite/Page 645), H01 (Seite/Page 646), H07 (Seite/Page 648)		

SP Legende
HM Legend

Scan
 Oder besuchen Sie // Or Visit
www.simtek.info/cp/968

Legende Legend **650**

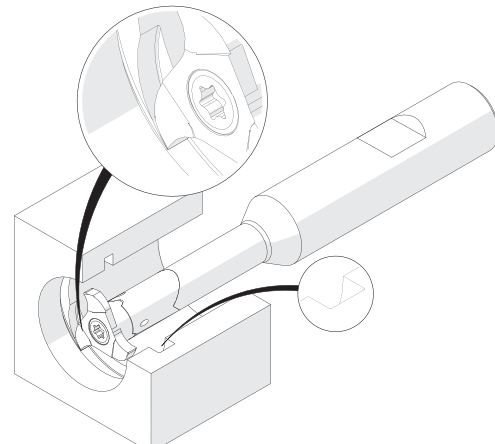
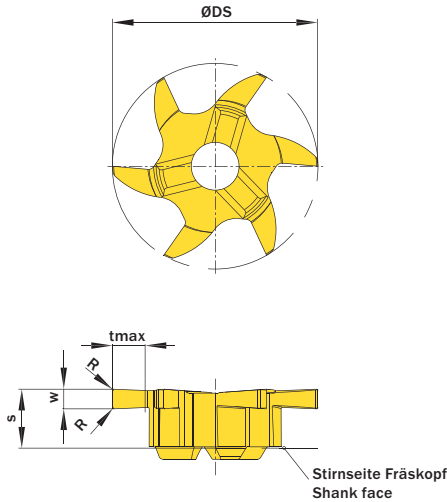


Illustration zeigt beispielhafte Anwendungsmöglichkeit mit ähnlichem Werkzeug.
 Image shows exemplary application possibility with similar tool.

Abbildung zeigt / Drawing shows: S06.0150.02.16 G

w ^{+0,02}	Nuttenbreite Nominal width of groove	R	ØDmin (Min. Bohrung) ØDmin (min. bore)	Artikelnummer Part number	Webcode www.simtek.com/webcode	Unsere erste Wahl Our first choice		tmax	S	ØDS	ZEFP	Connectcode www.simtek.com/ccode
						P M K N S	G T					
1,5	-	0,2	16,0	S06.0150.02.16 G	AU7Z	X800	G142	3,5	4,5	15,7	6	SD08.0
2,0	-	0,2	16,0	S06.0200.02.16 G	AU70	X800	G142	3,5	4,5	15,7	6	SD08.0
2,5	-	0,2	16,0	S06.0250.02.16 G	AU71	X800	G142	3,5	4,5	15,7	6	SD08.0

Bestellbeispiel // Order example: **S06.0250.02.16 G X800** (X800 = Schneidstoff // Grade)



S06. w, 1/100 mm, 4 Stellen/Digits . R, 1/100 mm, 3 Stellen/Digits .16 Toleranz // Tolerance

Beispielartikelnummer // Example Part number: **S06.0179.030.16 XG**

simmill AX
simmill PMX
simmill PX
simmill SX
simmill UX
simmill VX
simmill H2
simmill K2
simmill MX
simmill OS
Index

Fräsen von Sicherungsringnuten, innen

Fräsen von Sicherungsringnuten in Bohrungen ab Bohrungsdurchmesser 16,0 mm. Geeignet für alle Materialien.

Circlip Ring Groove Milling, internal

Circlip ring groove milling in bores as of bore diameter 16,0 mm. For use in most materials.

Schnittwerte (Start) // Cutting parameters (start)

fzm 0,02 mm	hmax 0,03 mm	Vc Seite/Page 638
-----------------------	------------------------	-----------------------------

Passende Klemmhalter auf Seite // Suitable toolholders on page
508, 509, 510, 511, 512

Vergleichbare Werkzeuge auf Seite // Similar tools on page
463

Bitte Hinweise im Anhang beachten // Please read add. notes

ALL (Seite/Page 645), H01 (Seite/Page 646), H07 (Seite/Page 648)



SP Legende
HM Legend
650

Scan QR-Code Oder besuchen Sie // Or Visit
www.simtek.info/cp/1138

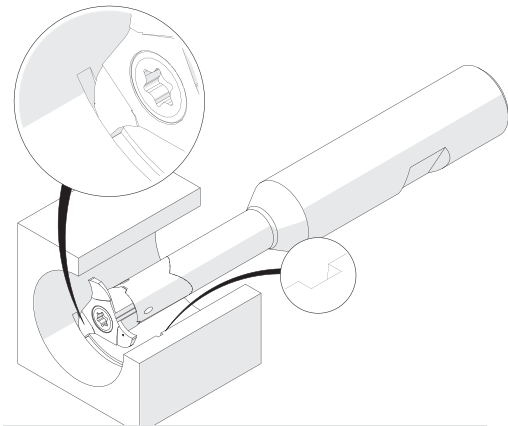
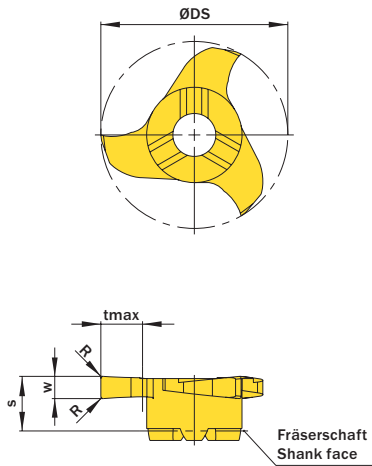


Illustration zeigt beispielhafte Anwendungsmöglichkeit mit ähnlichem Werkzeug.
 Image shows exemplary application possibility with similar tool.

w ^{-0,01}	Nutnenbreite Nominal width of groove	R	ØDmin (Min. Bohrung) ØDmin (min. bore)	Artikelnummer Part number	Webcode www.simtek.com/webcode	Unsere erste Wahl Our first choice	tmax	S	ØDS	ZEFP	Connectcode www.simtek.com/ccode
mm	mm	mm	mm			P M K N S X800 GT42	mm	mm	mm		
1,74	1,6	0,1	16,0	S16.0160.01 G	AJ4J	X800 GT42	3,5	4,5	15,7	3	SD08.0

Bestellbeispiel // Order example: **S16.0160.01 G X800** (X800 = Schneidstoff // Grade)

Allgemeines Nutfräsen, für weiche Schnitte

Nutfräsen gerader Nutformen. Weiches Eintauchen in den Werkstückstoff und bessere Oberflächen durch optimierte Schneidengeometrie. Geeignet ab Bohrungsdurchmesser 16,0 mm.

General Groove Milling, for smooth cuts

General groove milling. With a new cutting edge geometry for very smooth cuts and better surface quality. For use in bores as of minimum bore diameter 16,0 mm.

Schnittwerte (Start) // Cutting parameters (start)		
fzm 0,02 mm	hmax 0,03 mm	Vc Seite/Page 638
Passende Klemmhalter auf Seite // Suitable toolholders on page		
508, 509, 510, 511, 512		
Vergleichbare Werkzeuge auf Seite // Similar tools on page		
461		
Bitte Hinweise im Anhang beachten // Please read add. notes		
ALL (Seite/Page 645), H01 (Seite/Page 646), H07 (Seite/Page 648)		

SP

Legende

HM

Legend

650

Scan QR-Code Oder besuchen Sie // Or Visit www.simtek.info/cp/1122

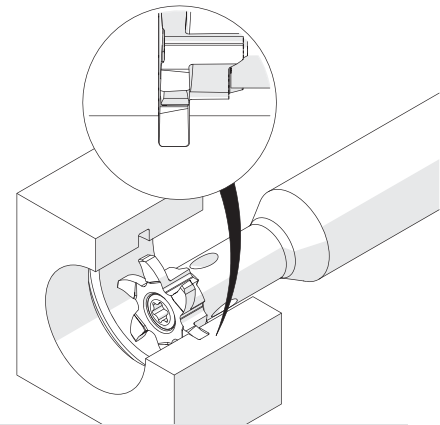
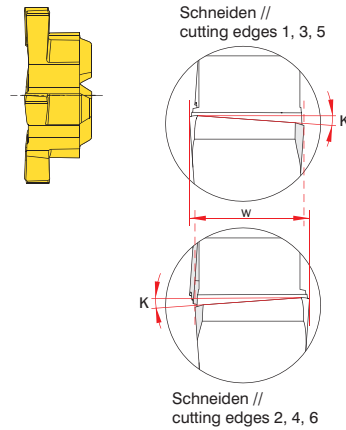
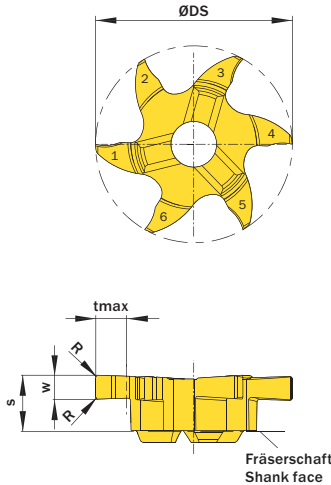


Illustration zeigt beispielhafte Anwendungsmöglichkeit mit ähnlichem Werkzeug.
 Image shows exemplary application possibility with similar tool.

Abbildung zeigt / Drawing shows: S06.0200.020.16 GY

w ^{+0,02}	Nutnenbreite Nominal width of groove	R	ØDmin (Min. Bohrung) ØDmin (min. bore)	Artikelnummer Part number	Webcode www.simtek.com/webcode	Unsere erste Wahl Our first choice	tmax	S	ØDS	ZEFP	Connectcode www.simtek.com/ccode
1,5	-	0,2	16,0	S06.0150.020.16 GY	AYF0	X800 GT42	3,5	4,5	15,7	6	SD08.0
2,0	-	0,2	16,0	S06.0200.020.16 GY	AYF1	X800 GT42	3,5	4,5	15,7	6	SD08.0
2,5	-	0,2	16,0	S06.0250.020.16 GY	AYF2	X800 GT42	3,5	4,5	15,7	6	SD08.0

Bestellbeispiel // Order example: **S06.0250.020.16 GY X800** (X800 = Schneidstoff // Grade)

simmill AX
simmill PMX
simmill PX
simmill SX
simmill UX
simmill VX
simmill H2
simmill K2
simmill MX
simmill OS
Index

Allgemeines Nutfräsen in Leichtmetall

Nutfräsen gerader Nutformen in Bohrungen ab Bohrungsdurchmesser 16,0 mm. Durch hochpositive Schneidengeometrie besonders geeignet für Leichtmetalle.

General Groove Milling in light alloys

General groove milling in bores as of bore diameter 16,0 mm. High positive rake angle for use in light alloys.

Schnittwerte (Start) // Cutting parameters (start)		
fzm 0,02 mm	hmax 0,03 mm	Vc Seite/Page 638

Passende Klemmhalter auf Seite // Suitable toolholders on page
508, 509, 510, 511, 512

Vergleichbare Werkzeuge auf Seite // Similar tools on page
462

Bitte Hinweise im Anhang beachten // Please read add. notes
ALL (Seite/Page 645), H01 (Seite/Page 646), H07 (Seite/Page 648)

SP

HM

LM

Legende
Legend

650

Scan
QR-Code

Oder besuchen Sie // Or Visit
www.simtek.info/cp/360

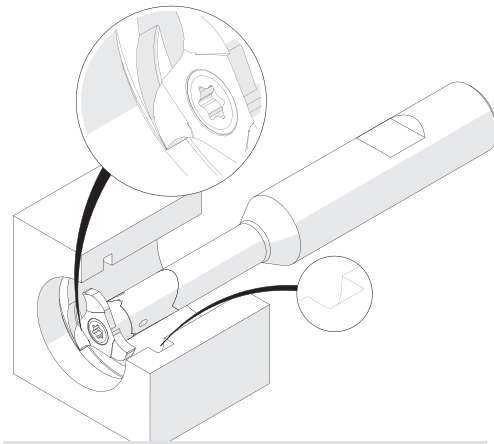
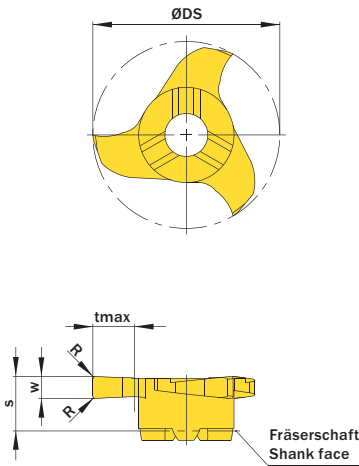


Illustration zeigt beispielhafte Anwendungsmöglichkeit mit ähnlichem Werkzeug.
 Image shows exemplary application possibility with similar tool.

Abbildung zeigt / Drawing shows: S16.0200.42 C

ØDmin (Min. Bohrung) ØDmin (min. bore)	w +0,02	Nuttenbreite Nominal width of groove	R	Artikelnummer Part number	Webcode www.simtek.com/webcode	Unsere erste Wahl Our first choice	ZEFP	ØDS	s	tmax	Connectcode www.simtek.com/code
mm	mm	mm	mm			P M K N S		mm	mm	mm	
16,0	1,04	-	-	S16.0100.40 C	AX5H	X800 GT42	3	15,7	4,5	3,5	SD08.0
16,0	2,0	-	0,2	S16.0200.42 C	ANVD	X800 GT42	3	15,7	4,5	3,5	SD08.0
16,0	2,5	-	0,2	S16.0250.42 C	AF2X	X800 GT42	3	15,7	4,5	3,5	SD08.0

Bestellbeispiel // Order example: **S16.0200.42 C X800** (X800 = Schneidstoff // Grade)

simtek individual | S16. w, 1/100 mm, 4 Stellen/Digits . R, 1/100 mm, 3 Stellen/Digits | Toleranz // Tolerance **C**
 Beispielartikelnummer // Example Part number: **S16.0179.030 XG C**

Fräsen von Vollradiusnuten

Nutfräsen runder Nutformen.
 Geeignet ab Bohrungsdurchmesser 16,0 mm.

Full Radius Groove Milling

Full radius groove milling.
 For use in bores as of minimum bore diameter 16,0 mm.

Schnittwerte (Start) // Cutting parameters (start)		
fzm 0,02 mm	hmax 0,03 mm	Vc Seite/Page 638
Passende Klemmhalter auf Seite // Suitable toolholders on page 508, 509, 510, 511, 512		
Vergleichbare Werkzeuge auf Seite // Similar tools on page 465		
Bitte Hinweise im Anhang beachten // Please read add. notes ALL (Seite/Page 645), H01 (Seite/Page 646), H07 (Seite/Page 648)		

SP Legende
HM Legend

Scan
 Oder besuchen Sie // Or Visit
www.simtek.info/cp/401

650

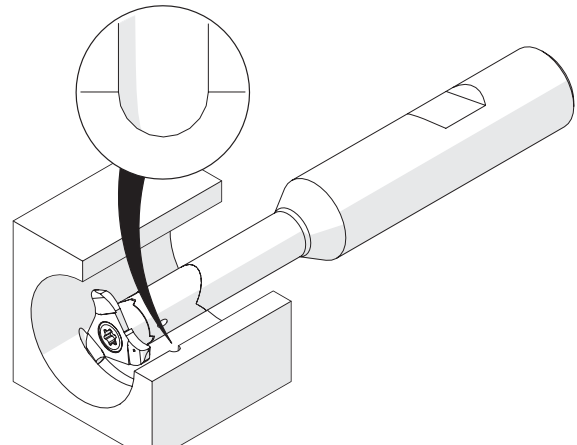
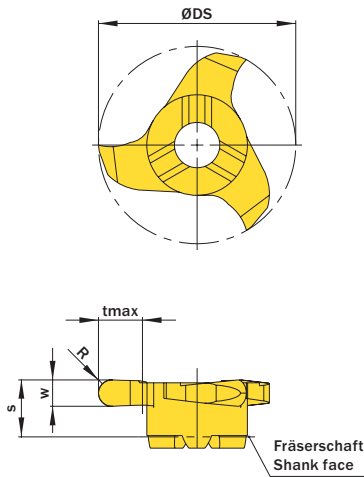


Illustration zeigt beispielhafte Anwendungsmöglichkeit mit ähnlichem Werkzeug.
 Image shows exemplary application possibility with similar tool.

Abbildung zeigt / Drawing shows: S16.0011.22 V

R	w ^{+0,03}	ØDmin (Min. Bohrung) ØDmin (min. bore)	Artikelnummer Part number	Webcode www.simtek.com/webcode	Unsere erste Wahl Our first choice	tmax	S	ØDS	ZEFP	Connectcode www.simtek.com/code
mm	mm	mm			P M K N S	mm	mm	mm		
1,1	2,2	16,0	S16.0011.22 V	ACJP	X800 GT42	3,5	4,5	15,7	3	SD08.0

Bestellbeispiel // Order example: **S16.0011.22 V X800** (X800 = Schneidstoff // Grade)

Metrisches ISO-Gewindefräsen, Teilprofil

Ausgelegt als Mehrbereichswerkzeuge. Die angegebene „Steigung (von)“ ist normgerecht. Die „Steigung (bis)“ kann ebenfalls realisiert werden. Vgl. Hinweistexte.

Thread milling, metric ISO-Thread, partial profile

Multi-purpose milling inserts. The given „Pitch (as of)“ is conforming to standards. The „Pitch (up to)“ is possible too at the expense of conformity. Please read additional notes.

Schnittwerte (Start) // Cutting parameters (start)		
fzm 0,02 mm	hmax 0,03 mm	Vc Seite/Page 638

Passende Klemmhalter auf Seite // Suitable toolholders on page
508, 509, 510, 511, 512

Vergleichbare Werkzeuge auf Seite // Similar tools on page
466

Bitte Hinweise im Anhang beachten // Please read add. notes

ALL (Seite/Page 645), H03 (Seite/Page 647), H04 (Seite/Page 648), H07 (Seite/Page 648)

SP

Legende
Legend

HM

Legende
Legend

650

Scan
QR-Code

Oder besuchen Sie // Or Visit
www.simtek.info/cp/970

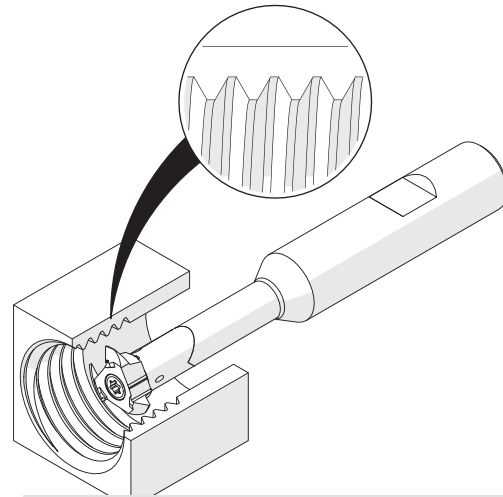
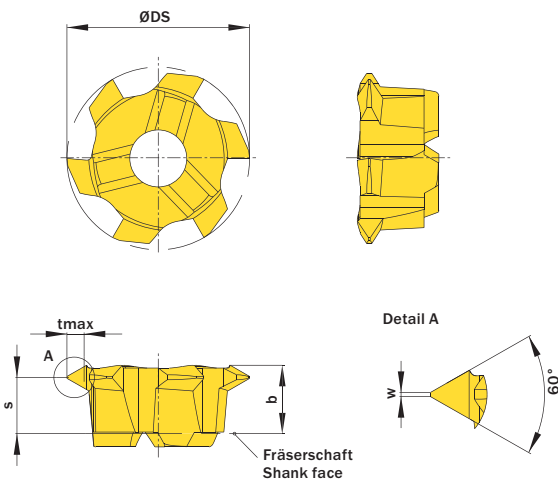


Illustration zeigt beispielhafte Anwendungsmöglichkeit mit ähnlichem Werkzeug.
 Image shows exemplary application possibility with similar tool.

Abbildung zeigt / Drawing shows: S06.0720.01.12 M

Ab Gewindegroße As of thread size	Steigung (von) Pitch (as of)	Steigung (bis) Pitch (up to)	Artikelnummer Part number	Webcode www.simtek.com/webcode	Unsere erste Wahl Our first choice		b	S	w	tmax	ØDS	ZEFP	Connectcode www.simtek.com/ccode
	mm	mm			PMKN	S							
M16	1,0	1,75	S06.0510.01.12 M	AU72	X800	GT42	4,2	3,4	0,13	1,08	12,0	6	SD08.0 SD09.5
M16	1,0	2,0	S06.0720.01.12 M	AU73	X800	GT42	4,2	3,6	0,13	1,25	12,3	6	SD08.0 SD09.5
M18	1,5	2,75	S06.0815.01.13 M	AU74	X800	GT42	4,2	3,0	0,19	1,67	13,2	6	SD08.0 SD09.5
M18	2,0	3,0	S06.2530.01.13 M	AU75	X800	GT42	4,2	2,8	0,25	1,78	13,3	6	SD08.0 SD09.5

Bestellbeispiel // Order example: **S06.2530.01.13 M X800** (X800 = Schneidstoff // Grade)

Die angegebene Gewindegroßenbezeichnung bezieht sich auf die Startsteigung.
 The mentioned thread size „As of thread size“ is based on the starting pitch.

Bitte beachten Sie die zusätzlichen Hinweise zu den Mehrbereichswerkzeugen im Infobereich rechts oben.
 Please read the additional notes mentioned in the information area on the top right corner of this page.

Mehr Infos zu den **Mehrbereichswerkzeugen** und deren **Gewindegroßenbezeichnung** finden Sie auf Seite 649

More information about the **multi-purpose thread milling tools** and the **thread size suitability** can be found on page 649

Metrisches ISO-Gewindefräsen, Teilprofil

Ausgelegt als Mehrbereichswerkzeuge. Die angegebene „Steigung (von)“ ist normgerecht. Die „Steigung (bis)“ kann ebenfalls realisiert werden. Vgl. Hinweistexte.

Thread milling, metric ISO-Thread, partial profile

Multi-purpose milling inserts. The given „Pitch (as of)“ is conforming to standards. The „Pitch (up to)“ is possible too at the expense of conformity. Please read additional notes.

Schnittwerte (Start) // Cutting parameters (start)		
fzm 0,02 mm	hmax 0,03 mm	Vc Seite/Page 638
Passende Klemmhalter auf Seite // Suitable toolholders on page 508, 509, 510, 511, 512		
Vergleichbare Werkzeuge auf Seite // Similar tools on page 466		
Bitte Hinweise im Anhang beachten // Please read add. notes ALL (Seite/Page 645), H03 (Seite/Page 647), H04 (Seite/Page 648), H07 (Seite/Page 648)		

SP Legende
HM Legend

Scan
 Oder besuchen Sie // Or Visit
www.simtek.info/cp/393

650

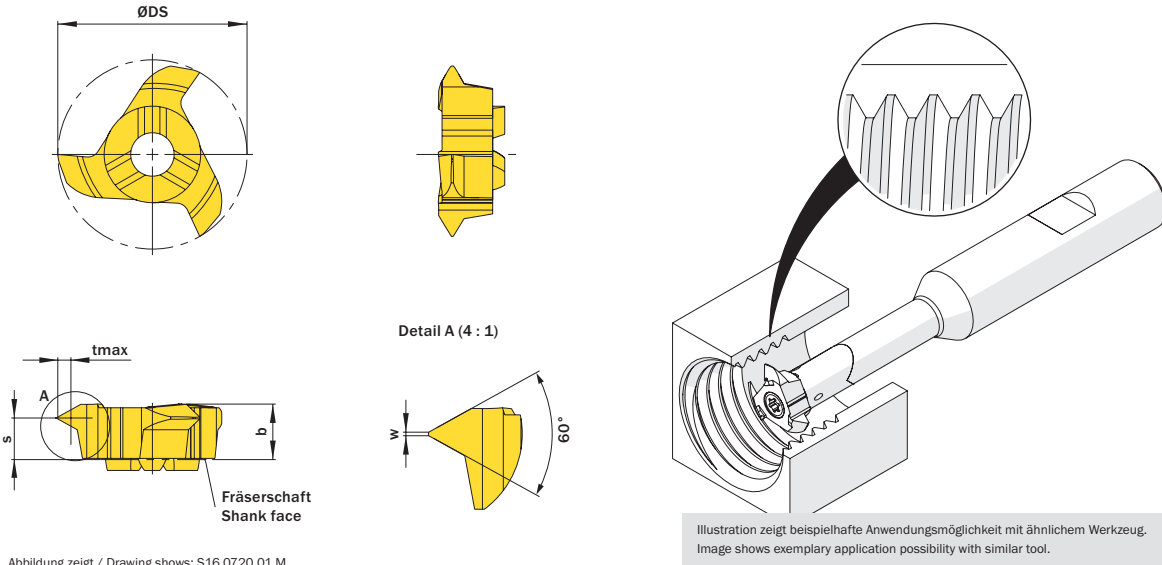


Abbildung zeigt / Drawing shows: S16.0720.01 M

Illustration zeigt beispielhafte Anwendungsmöglichkeit mit ähnlichem Werkzeug.
 Image shows exemplary application possibility with similar tool.

Ab Gewindegröße As of thread size	Steigung (von) Pitch (as of)	Steigung (bis) Pitch (up to)	Artikelnummer Part number	Webcode www.simtek.com/webcode	Unsere erste Wahl Our first choice		b	S	w	tmax	ØDS	ZEFP	Connectcode www.simtek.com/ccode
					P	M							
M18	1,0	1,75	S16.0510.01 M	AA4J	X800	GT42	4,6	3,8	0,12	1,08	15,7	3	SD08.0 SD09.5
M18	1,0	2,0	S16.0720.01 M	AJE4	X800	GT42	4,6	3,5	0,12	1,25	15,7	3	SD08.0 SD09.5
M20	1,5	2,75	S16.0815.01 M	AGS8	X800	GT42	4,6	3,5	0,19	1,67	15,7	3	SD08.0 SD09.5
M22	2,5	3,0	S16.2530.01 M	AEES	X800	GT42	4,6	3,4	0,31	1,78	15,7	3	SD08.0 SD09.5

Bestellbeispiel // Order example: **S16.0815.01 M X800** (X800 = Schneidstoff // Grade)

Bitte beachten Sie die zusätzlichen Hinweise zu den Mehrbereichswerkzeugen im Infobereich rechts oben.
 Please read the additional notes mentioned in the information area on the top right corner of this page.

Die angegebene Gewindegrößeneignung bezieht sich auf die Startsteigung.
 The mentioned thread size „As of thread size“ is based on the starting pitch.

Mehr Infos zu den **Mehrbereichswerkzeugen** und deren **Gewindegrößeneignung** finden Sie auf Seite 649

More information about the **multi-purpose thread milling tools** and the **thread size suitability** can be found on page 649

Metrisches ISO-Gewindefräsen, Vollprofil

Fräsen von metrischen ISO-Gewinden, Vollprofil.

Thread milling, metric ISO-Thread, full profile

Thread milling of metric ISO-thread, full profile.

Schnittwerte (Start) // Cutting parameters (start)		
f _{zm} 0,02 mm	h _{max} 0,03 mm	V _c Seite/Page 638

Passende Klemmhalter auf Seite // Suitable toolholders on page
508, 509, 510, 511, 512

Vergleichbare Werkzeuge auf Seite // Similar tools on page
467

Bitte Hinweise im Anhang beachten // Please read add. notes
ALL (Seite/Page 645), H06 (Seite/Page 648), H07 (Seite/Page 648)

SP

HM

Scan QR-Code

Legende
Legend **650**

Oder besuchen Sie // Or Visit
www.simtek.info/cp/1087

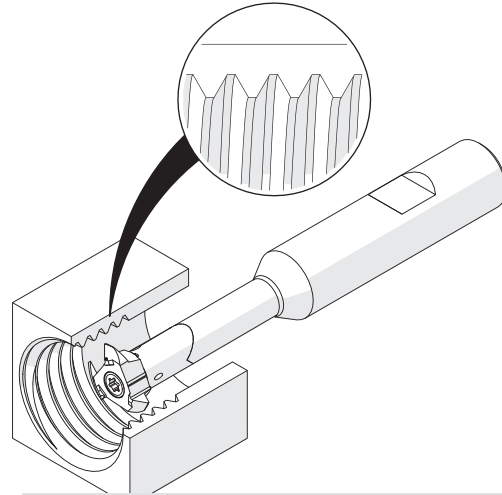
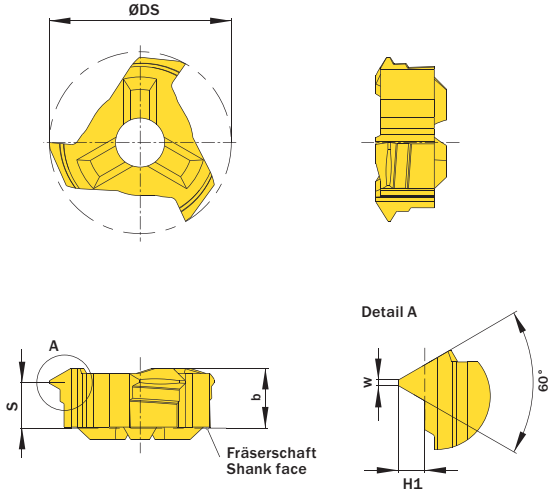


Illustration zeigt beispielhafte Anwendungsmöglichkeit mit ähnlichem Werkzeug.
 Image shows exemplary application possibility with similar tool.

Abbildung zeigt / Drawing shows: S14.0815.02 M

Ab Gewindegröße As of thread size	Ab Gewindeneindurchmesser // As of nominal thread diameter		Steigung (von) Pitch (as of)	Artikelnummer Part number	Webcode www.simtek.com/webcode	Unsere erste Wahl Our first choice				ZEFP	b	ØDS	S	w	Connectcode www.simtek.com/code	upd
	mm	H1				P	M	K	N							
M16	15,64	0,54	1,0	S14.0510.02 M	AXXY	X800	G142	3	4,5	13,7	3,6	0,13	SD08.0	SD09.5	upd	
M18	17,57	0,81	1,5	S14.0815.02 M	AXXZ	X800	G142	3	4,5	13,7	3,5	0,19	SD08.0	SD09.5	upd	
M20	18,65	0,95	1,75	S14.0917.02 M	AXX0	X800	G142	3	4,5	13,7	3,4	0,21	SD08.0	SD09.5	upd	
M20	19,8	1,08	2,0	S14.1020.02 M	AXX1	X800	G142	3	4,5	13,7	3,3	0,25	SD08.0	SD09.5	upd	
M22	20,9	1,35	2,5	S14.1325.02 M	AXX2	X800	G142	3	4,5	13,7	3,1	0,31	SD08.0	SD09.5	upd	
M22	21,95	1,62	3,0	S14.1630.02 M	AXX3	X800	G142	3	4,5	13,7	2,9	0,37	SD08.0	SD09.5	upd	

Bestellbeispiel // Order example: **S14.1325.02 M X800** (X800 = Schneidstoff // Grade)

Whitworth-Rohrgewinde, Vollprofil

Fräsen von Whitworth-Rohrgewinden,
 Vollprofil mit sechs Schneiden und Werkzeug-Schneidkreis von 13,7 mm.

Whitworth Pipe Thread Milling, full profile

Whitworth pipe thread milling,
 full profile with six cutting edges and tool diameter of 13,7 mm.

Schnittwerte (Start) // Cutting parameters (start)		
fzm 0,02 mm	hmax 0,03 mm	Vc Seite/Page 638
Passende Klemmhalter auf Seite // Suitable toolholders on page		
508, 509, 510, 511, 512		
Vergleichbare Werkzeuge auf Seite // Similar tools on page		
468		
Bitte Hinweise im Anhang beachten // Please read add. notes		
ALL (Seite/Page 645), H07 (Seite/Page 648)		

SP Legende
HM Legend

Scan
 Oder besuchen Sie // Or Visit
www.simtek.info/cp/982

650

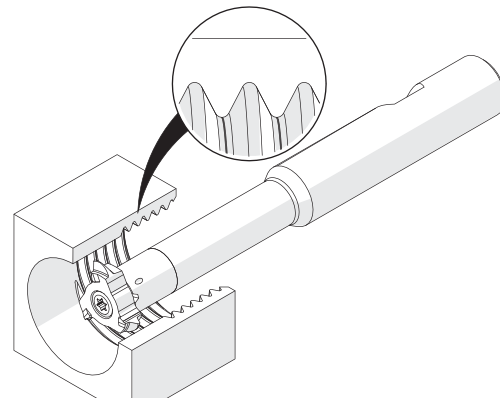
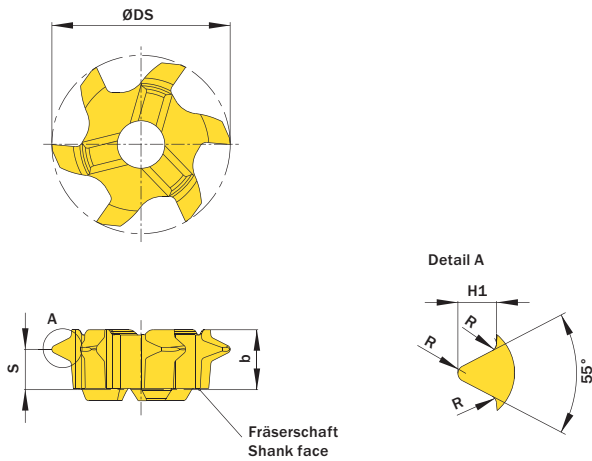


Illustration zeigt beispielhafte Anwendungsmöglichkeit mit ähnlichem Werkzeug.
 Image shows exemplary application possibility with similar tool.

Abbildung zeigt / Drawing shows: S06.1423.11.14 M

H1	Steigung (von) Pitch (as of)	Gang/Zoll Threads/inch	Artikelnummer Part number	Webcode www.simtek.com/webcode	Unsere erste Wahl Our first choice		R	b	S	ØDS	Ab Gewindegröße As of thread size	Alternativ ab Nenndurchmesser Alternativ as of nominal diameter	ZEFP	Connectcode www.simtek.com/ccode
	mm				mm	P								
1,16	1,81	14	S06.1118.14.14 M	AVKB	X800	G142	0,24	4,6	3,3	13,7	G 1/2"	17,5	6	SD08.0 SD09.5
1,48	2,31	11	S06.1423.11.14 M	AVKC	X800	G142	0,31	4,6	3,1	13,7	G 1"	18,8	6	SD08.0 SD09.5

Bestellbeispiel // Order example: **S06.1118.14.14 M X800** (X800 = Schneidstoff // Grade)

simmill AX
simmill PMX
simmill PX
simmill SX
simmill UX
simmill VX
simmill H2
simmill K2
simmill MX
simmill OS
Index

Whitworth-Rohrgewinde, Vollprofil

Fräsen von Whitworth-Rohrgewinden,
 Vollprofil mit drei Schneiden und Werkzeug-Schneidkreis von 15,7 mm.

Whitworth Pipe Thread Milling, full profile

Whitworth pipe thread milling,
 full profile with three cutting edges and tool diameter of 15,7 mm.

Schnittwerte (Start) // Cutting parameters (start)		
fzm	hmax	Vc
0,02 mm	0,03 mm	Seite/Page 638

Passende Klemmhalter auf Seite // Suitable toolholders on page
508, 509, 510, 511, 512

Vergleichbare Werkzeuge auf Seite // Similar tools on page
468

Bitte Hinweise im Anhang beachten // Please read add. notes
ALL (Seite/Page 645), H07 (Seite/Page 648)

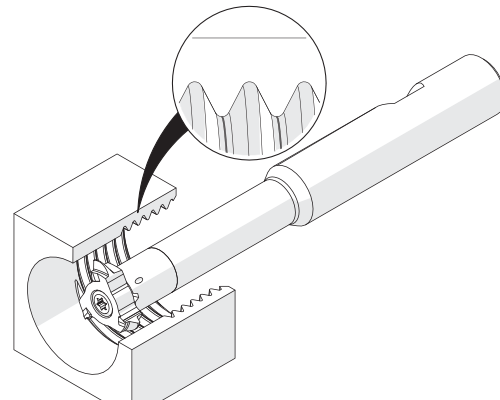
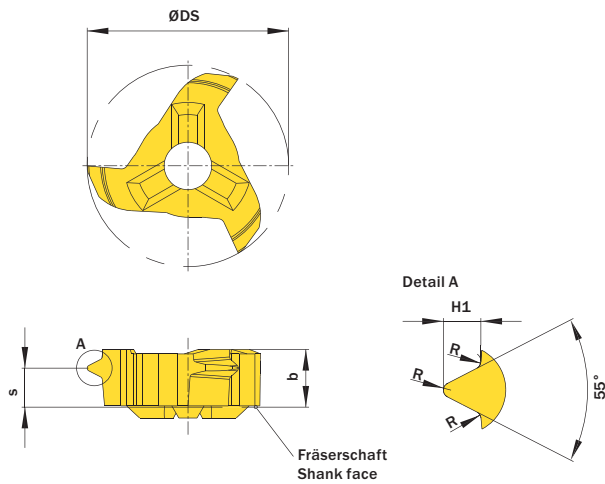


Illustration zeigt beispielhafte Anwendungsmöglichkeit mit ähnlichem Werkzeug.
 Image shows exemplary application possibility with similar tool.

Abbildung zeigt / Drawing shows: S16.1118.14 M

H1	Steigung (von) Pitch (as of)	Gang/Zoll Threads/inch	Artikelnummer Part number	Webcode www.simtek.com/webcode	Unsere erste Wahl Our first choice	R	b	S	ØDS	Ab Gewindegröße As of thread size	Alternativ ab Nennmesser Alternativ as of nominal diameter	ZEFP	Connectcode www.simtek.com/ccode
mm	mm				P M K N S	mm	mm	mm	mm		mm		
1,17	1,814	14	S16.1118.14 M	AT8A	X800 G142	0,24	4,5	3,0	15,7	G 5/8"	22,0	3	SD08.0 SD09.5
1,48	2,309	11	S16.1423.11 M	AT79	X800 G142	0,31	4,5	2,8	15,7	G 1"	23,5	3	SD08.0 SD09.5

Bestellbeispiel // Order example: **S16.1118.14 M X800** (X800 = Schneidstoff // Grade)

Fräsen von Fasen

Fasenfräsen beidseitig.
 Geeignet ab Bohrungsdurchmesser 14,0 mm.

Chamfering

Chamfering on both sides.
 For use in bores as of minimum bore diameter 14,0 mm.

Schnittwerte (Start) // Cutting parameters (start)

fzm	hmax	Vc
0,02 mm	0,03 mm	Seite/Page 638

Passende Klemmhalter auf Seite // Suitable toolholders on page
508, 509, 510, 511, 512

Vergleichbare Werkzeuge auf Seite // Similar tools on page
469

Bitte Hinweise im Anhang beachten // Please read add. notes
ALL (Seite/Page 645), H07 (Seite/Page 648)

SP

Legende

650

HM

Legende

Scan QR-Code

Oder besuchen Sie // Or Visit

www.simtek.info/cp/972

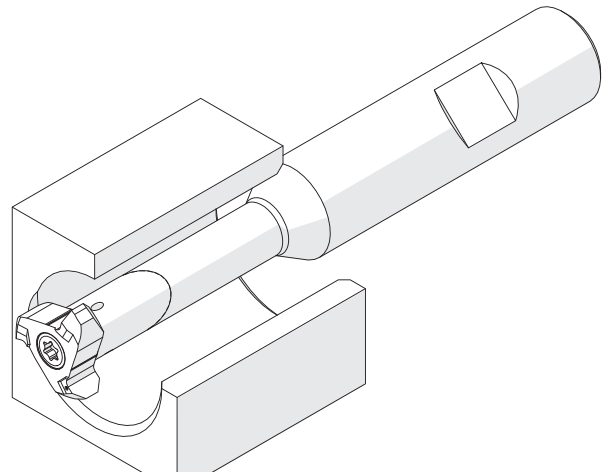
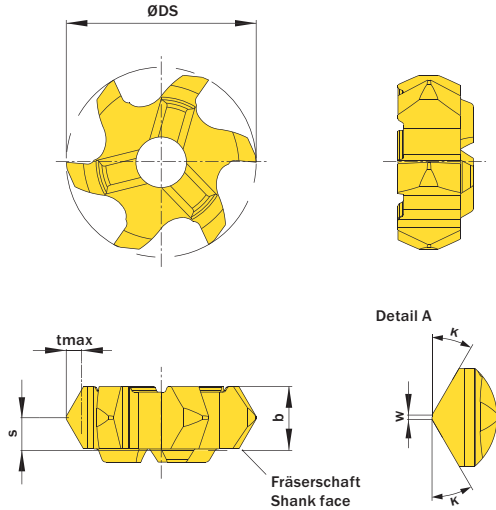


Illustration zeigt beispielhafte Anwendungsmöglichkeit mit ähnlichem Werkzeug.
 Image shows exemplary application possibility with similar tool.

Abbildung zeigt / Drawing shows: S06.3030.02.14 F

K	w mm	ØDmin (Min. Bohrung) ØDmin (min. bore) mm	Artikelnummer Part number	Webcode www.simtek.com/webcode	Unsere erste Wahl Our first choice				b mm	S mm	tmax mm	ØDS mm	ZEFP	Connectcode www.simtek.com/ccode
					P	M	K	N						
15°	0,2	14,0	S06.1515.02.14 F	AU77	X800	GT42			4,6	2,4	0,35	13,7	6	SD08.0 SD09.5
20°	0,2	14,0	S06.2020.02.14 F	AU78	X800	GT42			4,6	2,4	0,45	13,7	6	SD08.0 SD09.5
30°	0,2	14,0	S06.3030.02.14 F	AU79	X800	GT42			4,6	2,4	0,7	13,7	6	SD08.0 SD09.5
45°	0,2	14,0	S06.4545.02.14 F	AU76	X800	GT42			4,6	2,4	1,8	13,7	6	SD08.0 SD09.5

Bestellbeispiel // Order example: **S06.4545.02.14 F X800** (X800 = Schneidstoff // Grade)

simmill AX
simmill PMX
simmill PX
simmill SX
simmill UX
simmill VX
simmill H2
simmill K2
simmill MX
simmill OS
Index

Fräsen von Fasen

Fasenfräsen beidseitig.
Geeignet ab Bohrungsdurchmesser 16,0 mm.

Chamfering

Chamfering on both sides.
For use in bores as of minimum bore diameter 16,0 mm.

Schnittwerte (Start) // Cutting parameters (start)

fzm	hmax	Vc
0,02 mm	0,03 mm	Seite/Page 638

Passende Klemmhalter auf Seite // Suitable toolholders on page
508, 509, 510, 511, 512

Vergleichbare Werkzeuge auf Seite // Similar tools on page
469

Bitte Hinweise im Anhang beachten // Please read add. notes
ALL (Seite/Page 645), H07 (Seite/Page 648)



SP Legende
HM Legend
650

Scan QR-Code Oder besuchen Sie // Or Visit
www.simtek.info/cp/406

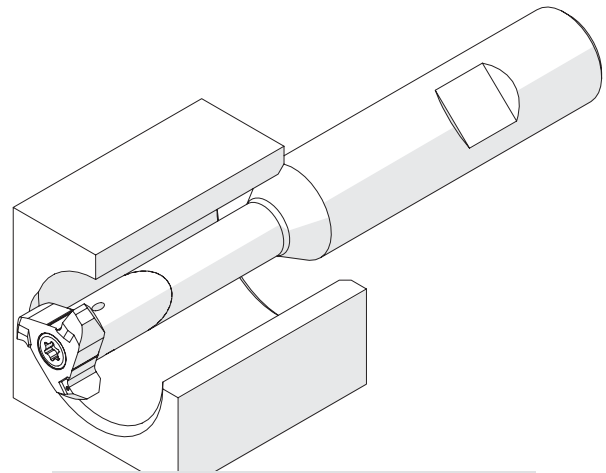
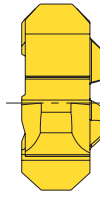
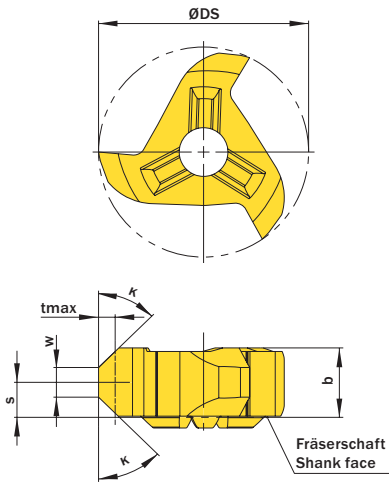


Illustration zeigt beispielhafte Anwendungsmöglichkeit mit ähnlichem Werkzeug.
Image shows exemplary application possibility with similar tool.

Abbildung zeigt / Drawing shows: S16.4545.58 F

K	W	ØDmin (Min. Bohrung) ØDmin (min. bore)	Artikelnummer Part number	Webcode www.simtek.com/webcode	Unsere erste Wahl Our first choice		tmax	b	S	ØDS	ZEFP	Connectcode www.simtek.com/ccode
					P	M						
45°	0,2	16,0	S16.4545.02 F	AF2U	X800	G142	1,8	4,6	2,3	15,7	3	SD08.0 SD09.5
45°	1,4	16,0	S16.4545.45 F	AH98	X800	G142	1,4	4,5	2,3	15,7	3	SD08.0 SD09.5

Bestellbeispiel // Order example: **S16.4545.02 F X800** (X800 = Schneidstoff // Grade)

Fräsen von Schwalbenschwanznuten

Schneidkreisdurchmesser ab 15,7 mm mit 6 Schneiden.

Dovetail milling

Tool diameter of 15,7 mm with 6 cutting edges.

Schnittwerte (Start) // Cutting parameters (start)		
fzm	hmax	Vc
0,02 mm	0,03 mm	Seite/Page 638

Passende Klemmhalter auf Seite // Suitable toolholders on page
508, 509, 510, 511, 512

Bitte Hinweise im Anhang beachten // Please read add. notes
ALL (Seite/Page 645), H07 (Seite/Page 648)

SP

Legende

HM

Legende

650

Scan QR-Code

Oder besuchen Sie // Or Visit www.simtek.info/cp/1386

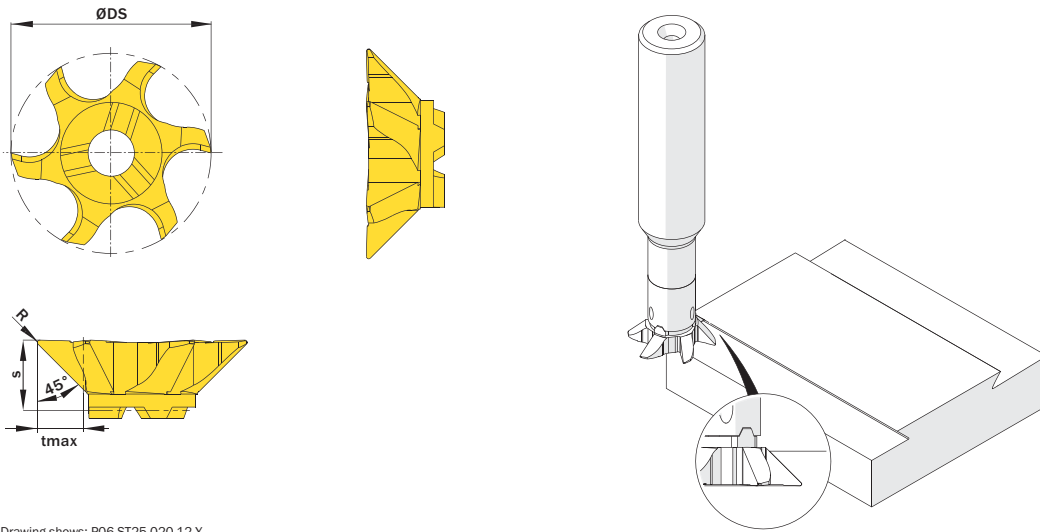


Abbildung zeigt / Drawing shows: P06.ST25.020.12 Y

tmax	R	ØDmin (Min. Bohrung) ØDmin (min. bore)	Artikelnummer Part number	Webcode www.simtek.com/webcode	Unsere erste Wahl Our first choice	S	ØDS	ZEFP	Connectcode www.simtek.com/code
mm	mm	mm			P M K N S	mm	mm		
2,5	0,2	16,0	S06.ST25.020.16 Y	A03J	X800 GT42	4,5	15,7	6	SD08.0 new

Bestellbeispiel // Order example: **S06.ST25.020.16 Y X800** (X800 = Schneidstoff // Grade)

simmillUX
SIMTEK milling tools type UX



Ab Seite // As of page

461

Anwendungsübersicht
Application overview

Fräserschaft, zylindrisch (vgl. DIN 6535 HA)

Schwingungsgedämpfte Hartmetall-Ausführung mit innerer Kühlmittelzufuhr und Aufnahme nach DIN 6535 HA.

Milling Cutter Shank, cylindrical (DIN 6535 HA)

Anti-vibration solid carbide type with through coolant and shank according to DIN 6535 HA.

Anzugsmoment (Schraube) // Tightening torque (screw)

4,5 Nm

Vergleichbare Werkzeuge auf Seite // Similar tools on page
473

Bitte Hinweise im Anhang beachten // Please read add. notes
ALL (Seite/Page 645)

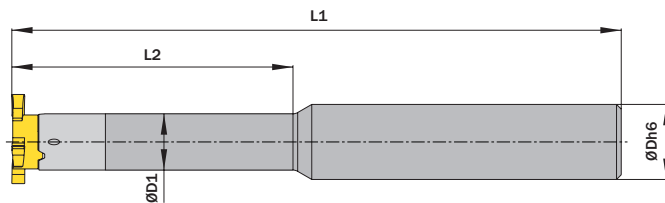


Legende
Legend **650**



Scan
QR-Code

Oder besuchen Sie // Or Visit
www.simtek.info/cp/271



ØDh6	ØD1	L2	Artikelnummer Part number	Webcode www.simtek.com/webcode	L1	Schraube Screw	Schraubenschlüssel Screw driver	Connectcode www.simtek.com/code
mm	mm	mm			mm			
▼ ØDh6 = 12,0 mm								
12,0	9,0	32,0	U18.1209.32 A HM	ACQC	100,0	U M4x12 T15F	T15F	UD09.0
12,0	9,0	45,0	U18.1209.45 A HM	AGK5	100,0	U M4x12 T15F	T15F	UD09.0
12,0	9,0	64,0	U18.1209.64 A HM	AGEV	120,0	U M4x12 T15F	T15F	UD09.0
▼ ØDh6 = 12,7 mm								
12,7	9,0	32,0	U18.0.500.09.32 A HM	AK8V	100,0	U M4x12 T15F	T15F	UD09.0 <small>inch</small>
12,7	9,0	45,0	U18.0.500.09.45 A HM	AH50	100,0	U M4x12 T15F	T15F	UD09.0 <small>inch</small>
12,7	9,0	64,0	U18.0.500.09.64 A HM	AD8F	120,0	U M4x12 T15F	T15F	UD09.0 <small>inch</small>
▼ ØDh6 = 15,875 mm								
15,875	9,0	25,0	U18.0.625.09.25 A HM	AE8X	93,0	U M4x12 T15F	T15F	UD09.0 <small>inch</small>
15,875	9,0	32,0	U18.0.625.09.32 A HM	ACQZ	100,0	U M4x12 T15F	T15F	UD09.0 <small>inch</small>
15,875	9,0	45,0	U18.0.625.09.45 A HM	AH0T	110,0	U M4x12 T15F	T15F	UD09.0 <small>inch</small>
15,875	9,0	64,0	U18.0.625.09.64 A HM	AK2U	130,0	U M4x12 T15F	T15F	UD09.0 <small>inch</small>
15,875	13,0	64,0	U18.0.625.13.64 A HM	AHQK	110,0	U M4x12 T15F	T15F	UD13.0 <small>inch</small>
15,875	13,0	66,0	U18.0.625.13.66 A HM	ADZE	130,0	U M4x12 T15F	T15F	UD13.0 <small>inch</small>
▼ ØDh6 = 16,0 mm								
16,0	9,0	25,0	U18.1609.25 A HM	AAD3	93,0	U M4x12 T15F	T15F	UD09.0
16,0	9,0	32,0	U18.1609.32 A HM	AAKX	100,0	U M4x12 T15F	T15F	UD09.0
16,0	9,0	45,0	U18.1609.45 A HM	AMCV	110,0	U M4x12 T15F	T15F	UD09.0
16,0	9,0	64,0	U18.1609.64 A HM	ANX9	130,0	U M4x12 T15F	T15F	UD09.0
16,0	13,0	64,0	U18.1613.64 A HM	AFVT	110,0	U M4x12 T15F	T15F	UD13.0
16,0	13,0	66,0	U18.1613.66 A HM	AD9W	130,0	U M4x12 T15F	T15F	UD13.0

Bestellbeispiel // Order example: **U18.1609.64 A HM**

simmill AX

simmill PMX

simmill PX

simmill SX

simmill UX

simmill VX

simmill H2

simmill K2

simmill MX

simmill OS

Index

Fräserschaft, zylindrisch (vgl. DIN 1835 A)

Stahl-Ausführung mit Aufnahme nach DIN 1835 A.

Milling cutter shank, cylindrical (DIN 1835 A)

Steel type with shank according to DIN 1835 A.

Anzugsmoment (Schraube) // Tightening torque (screw)

4,5 Nm

Vergleichbare Werkzeuge auf Seite // Similar tools on page
474

Bitte Hinweise im Anhang beachten // Please read add. notes
ALL (Seite/Page 645)



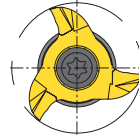
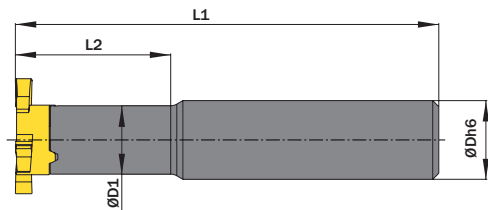
Legende **650**
Legend



Scan QR-Code

Oder besuchen Sie // Or Visit
www.simtek.info/cp/273

Whistle-Notch Aufnahme auf Anfrage erhältlich.
Whistle-Notch fixation available upon request.



ØDh6	ØD1	L2	Artikelnummer Part number	Webcode www.simtek.com/webcode	Mit Kühlmittelzufuhr With through coolant supply	L1	Schraube Screw	Schraubenschlüssel Screw driver	Connectcode www.simtek.com/code
mm	mm	mm				mm			
▼ ØDh6 = 10,0 mm									
10,0	9,0	17,0	U18.1009.17 A ST	AM1T	Nein / No	60,0	U M4x12 T15F	T15F	UD09.0
▼ ØDh6 = 12,0 mm									
12,0	9,0	18,0	U18.1209.18 A ST	AV6D	Ja / Yes	80,0	U M4x12 T15F	T15F	UD09.0
▼ ØDh6 = 13,0 mm									
13,0	9,0	25,0	U18.1309.25 A ST	AKZ5	Nein / No	70,0	U M4x12 T15F	T15F	UD09.0
▼ ØDh6 = 15,875 mm									
15,875	9,0	18,0	U18.0.625.09.18 A ST	AN7U	Ja / Yes	80,0	U M4x12 T15F	T15F	UD09.0
▼ ØDh6 = 16,0 mm									
16,0	9,0	18,0	U18.1609.18 A ST	AGU5	Ja / Yes	80,0	U M4x12 T15F	T15F	UD09.0

Inch

Bestellbeispiel // Order example: **U18.1609.18 A ST**

Fräserschaft, Weldon (vgl. DIN 6535 HB)

Schwingungsgedämpfte Hartmetall-Ausführung mit innerer Kühlmittelzufuhr und Aufnahme nach DIN 6535 HB.

Milling Cutter Shank, Weldon (DIN 6535 HB)

Anti-vibration solid carbide type with through coolant and shank according to DIN 6535 HB.

Anzugsmoment (Schraube) // Tightening torque (screw)

4,5 Nm

Vergleichbare Werkzeuge auf Seite // Similar tools on page

475

Bitte Hinweise im Anhang beachten // Please read add. notes

ALL (Seite/Page 645)

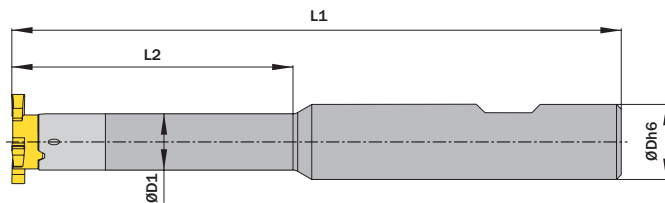


Legende
Legend **650**

Scan
QR-Code

Oder besuchen Sie // Or Visit
www.simtek.info/cp/270

Whistle-Notch Aufnahme auf Anfrage erhältlich.
Whistle-Notch fixation available upon request.



ØDh6	ØD1	L2	Artikelnummer Part number	Webcode www.simtek.com/webcode	L1	Schraube Screw	Schraubenschlüssel Screw driver	Connectcode www.simtek.com/code	
mm	mm	mm			mm				
▼ ØDh6 = 12,0 mm									
12,0	9,0	32,0	U18.1209.32 B HM	AHQG	100,0	U M4x12 T15F	T15F	UD09.0	
12,0	9,0	45,0	U18.1209.45 B HM	AGXG	100,0	U M4x12 T15F	T15F	UD09.0	
12,0	9,0	64,0	U18.1209.64 B HM	AC32	120,0	U M4x12 T15F	T15F	UD09.0	
▼ ØDh6 = 12,7 mm									
12,7	9,0	32,0	U18.0.500.09.32 B HM	AMW6	100,0	U M4x12 T15F	T15F	UD09.0 <small>inch</small>	
12,7	9,0	45,0	U18.0.500.09.45 B HM	AEW9	100,0	U M4x12 T15F	T15F	UD09.0 <small>inch</small>	
12,7	9,0	64,0	U18.0.500.09.64 B HM	AEYX	120,0	U M4x12 T15F	T15F	UD09.0 <small>inch</small>	
▼ ØDh6 = 15,875 mm									
15,875	9,0	25,0	U18.0.625.09.25 B HM	AET2	93,0	U M4x12 T15F	T15F	UD09.0 <small>inch</small>	
15,875	9,0	32,0	U18.0.625.09.32 B HM	ACQM	100,0	U M4x12 T15F	T15F	UD09.0 <small>inch</small>	
15,875	9,0	45,0	U18.0.625.09.45 B HM	AD9P	110,0	U M4x12 T15F	T15F	UD09.0 <small>inch</small>	
15,875	9,0	64,0	U18.0.625.09.64 B HM	AE40	130,0	U M4x12 T15F	T15F	UD09.0 <small>inch</small>	
15,875	13,0	64,0	U18.0.625.13.64 B HM	APQG	110,0	U M4x12 T15F	T15F	UD13.0 <small>inch</small>	
15,875	13,0	66,0	U18.0.625.13.66 B HM	AHS9	130,0	U M4x12 T15F	T15F	UD13.0 <small>inch</small>	
▼ ØDh6 = 16,0 mm									
16,0	9,0	25,0	U18.1609.25 B HM	AJ83	93,0	U M4x12 T15F	T15F	UD09.0	
16,0	9,0	32,0	U18.1609.32 B HM	AH75	100,0	U M4x12 T15F	T15F	UD09.0	
16,0	9,0	45,0	U18.1609.45 B HM	AA3N	110,0	U M4x12 T15F	T15F	UD09.0	
16,0	9,0	64,0	U18.1609.64 B HM	ACGX	130,0	U M4x12 T15F	T15F	UD09.0	
16,0	12,0	45,0	U18.1612.45 B HM	ADG9	110,0	U M4x12 T15F	T15F	UD12.0	
16,0	13,0	64,0	U18.1613.64 B HM	AMT0	110,0	U M4x12 T15F	T15F	UD13.0	
16,0	13,0	66,0	U18.1613.66 B HM	AJK6	130,0	U M4x12 T15F	T15F	UD13.0	

Bestellbeispiel // Order example: **U18.1609.64 B HM**

Fräserschaft, Weldon (vgl. DIN 1835 B)

Stahl-Ausführung mit innerer
 Kühlmittelzufuhr und Aufnahme nach DIN 1835 B.

Milling Cutter Shank, Weldon (DIN 1835 B)

Steel type with through coolant and shank according to DIN 1835 B.

Anzugsmoment (Schraube) // Tightening torque (screw)

4,5 Nm

Vergleichbare Werkzeuge auf Seite // Similar tools on page

476

Bitte Hinweise im Anhang beachten // Please read add. notes

ALL (Seite/Page 645)



Legende
 Legend

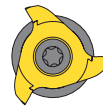
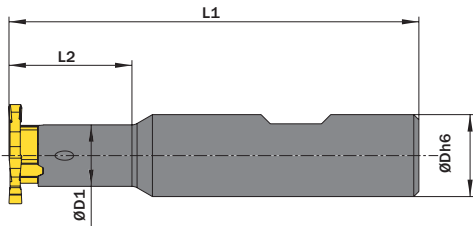
650



Scan
 QR-Code

Oder besuchen Sie // Or Visit
www.simtek.info/cp/422

Whistle-Notch Aufnahme auf Anfrage erhältlich.
 Whistle-Notch fixation available upon request.



ØDh6	ØD1	L2	Artikelnummer Part number	Webcode www.simtek.com/webcode	L1	Schraube Screw	Schraubenschlüssel Screw driver	Connectcode www.simtek.com/code
mm	mm	mm			mm			
▼ ØDh6 = 12,0 mm								
12,0	9,0	18,0	U18.1209.18 B ST	AV6E	80,0	UM4x12 T15F	T15F	UD09.0
▼ ØDh6 = 15,875 mm								
15,875	9,0	18,0	U18.0.625.09.18 B ST	AFHD	80,0	UM4x12 T15F	T15F	UD09.0
▼ ØDh6 = 16,0 mm								
16,0	9,0	18,0	U18.1609.18 B ST	ABP7	80,0	UM4x12 T15F	T15F	UD09.0

Inch

Bestellbeispiel // Order example: **U18.1609.18 B ST**

Fräserschaft, für Spannzangenfutter (DIN 6499)

Für Spannzangenfutter nach DIN6499-A.

Milling cutter shank, for collet chucks (DIN6499)

For collet chucks according to DIN6499-A.

Anzugsmoment (Schraube) // Tightening torque (screw)

4,5 Nm

Vergleichbare Werkzeuge auf Seite // Similar tools on page
472

Bitte Hinweise im Anhang beachten // Please read add. notes

ALL (Seite/Page 645)



TW
ST

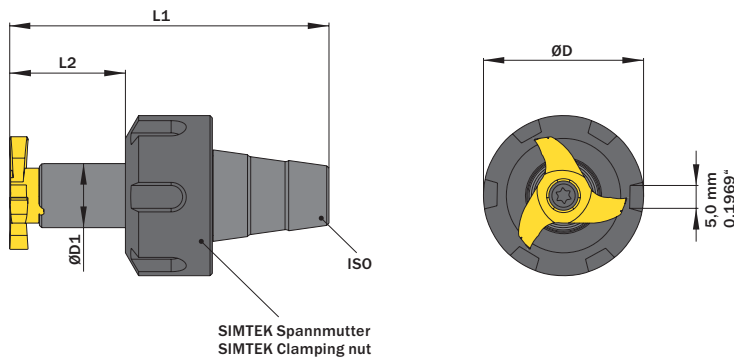
Legende
Legend

650



Scan
QR-Code

Oder besuchen Sie // Or Visit
www.simtek.info/cp/455



SIMTEK Spannmutter
SIMTEK Clamping nut

Fräserschaft ist nur mit passender Spannmutter verfügbar.
Spannmutter ist auch einzeln als Ersatzteil verfügbar.
Milling cutter shank is only available together with clamping nut.
Clamping nut is available as a spare part.

Für Spannzange For collet chuck	ØD1	L2	Artikelnummer Part number	Webcode www.simtek.com/webcode	Spannmutter Clamping nut	Gewinde Spannmutter Thread clamping nut	ØD	L1	Schraube Screw	Schraubenschlüssel Screw driver	Connectcode www.simtek.com/code
	mm	mm					mm	mm			
ER11	9,0	22,0	U18.ER11.09.22	AAV2	U ER11.12.19	M14x0,75	19,0	42,0	UM4x12 T15F	T15F	UD09.0
ER11	9,0	22,0	U18.ER11.09.22.B	AVMS	U ER11.12.16	M13x0,75	16,0	42,0	UM4x12 T15F	T15F	UD09.0
ER16	9,0	22,0	U18.ER16.09.22	APHJ	U ER16.18.32	M22x1,5	32,0	52,0	UM4x12 T15F	T15F	UD09.0
ER16	9,0	22,0	U18.ER16.09.22.B	AVMV	U ER16.18.22	M19x1,0	22,0	52,0	UM4x12 T15F	T15F	UD09.0
ER16	9,0	22,0	U18.ER16.09.22.C	AVMW	U ER16.18.25	M19x1,0	25,0	52,0	UM4x12 T15F	T15F	UD09.0
ER20	9,0	22,0	U18.ER20.09.22	AC9J	U ER20.19.35	M25x1,5	35,0	56,5	UM4x12 T15F	T15F	UD09.0
ER20	9,0	22,0	U18.ER20.09.22.B	AVM0	U ER20.19.28	M24x1,0	28,0	56,5	UM4x12 T15F	T15F	UD09.0
ER25	9,0	22,0	U18.ER25.09.22	AA1F	U ER25.20.42	M25x1,5	42,0	60,0	UM4x12 T15F	T15F	UD09.0
ER25	9,0	22,0	U18.ER25.09.22.B	AVM3	U ER25.20.35	M30x1,0	35,0	60,0	UM4x12 T15F	T15F	UD09.0

Bestellbeispiel // Order example: **U18.ER16.09.22.B**

Fräsen von Sicherungsringnuten, innen

Fräsen von Sicherungsringnuten in Bohrungen ab Bohrungsdurchmesser 18,0 mm. Geeignet für alle Materialien.

Circlip Ring Groove Milling, internal

Circlip ring groove milling in bores as of bore diameter 18,0 mm. For use in all materials.

Schnittwerte (Start) // Cutting parameters (start)		
fzm 0,03 mm	hmax 0,04 mm	Vc Seite/Page 638

Passende Klemmhalter auf Seite // Suitable toolholders on page
529, 530, 531, 532, 533

Vergleichbare Werkzeuge auf Seite // Similar tools on page
463

Bitte Hinweise im Anhang beachten // Please read add. notes

ALL (Seite/Page 645), H01 (Seite/Page 646), H05 (Seite/Page 648), H07 (Seite/Page 648)



SP Legende
HM Legend
650

Scan QR-Code Oder besuchen Sie // Or Visit
www.simtek.info/cp/365

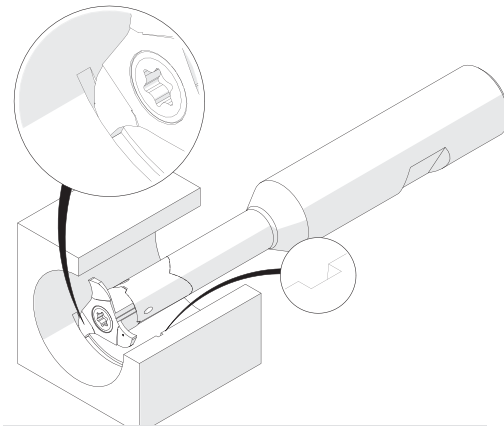
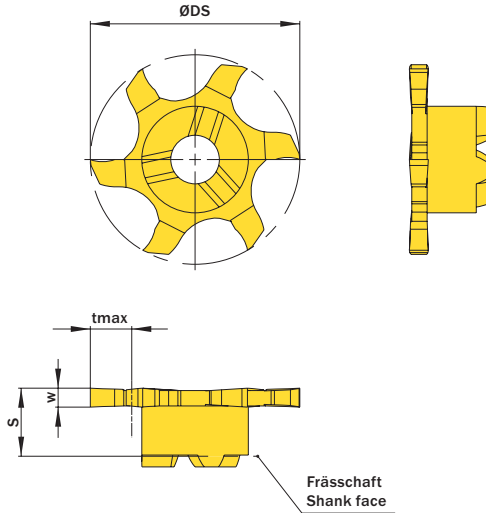


Illustration zeigt beispielhafte Anwendungsmöglichkeit mit ähnlichem Werkzeug.
Image shows exemplary application possibility with similar tool.

Abbildung zeigt / Drawing shows: U06.0160.000.18 G

w ^{-0,02}	Nuttenbreite Nominal width of groove	ØDmin (Min. Bohrung) ØDmin (min. bore)	Artikelnummer Part number	Webcode www.simtek.com/webcode	Unsere erste Wahl Our first choice	tmax	S	ØDS	ZEFP	Connectcode www.simtek.com/code
mm	mm	mm			P M K N S	mm	mm	mm		
1,24	1,1	18,0	U06.0110.000.18 G	AFYG	X800 G142	4,0	5,8	17,7	6	UD09.0 <small>upd</small>
1,44	1,3	18,0	U06.0130.000.18 G	ACUD	X800 G142	4,0	5,8	17,7	6	UD09.0 <small>upd</small>
1,74	1,6	18,0	U06.0160.000.18 G	AG2Y	X800 G142	4,0	5,8	17,7	6	UD09.0 <small>upd</small>

Bestellbeispiel // Order example: **U06.0130.000.18 G X800** (X800 = Schneidstoff // Grade)



U06. **w. 1/100 mm, 4 Stellen/Digits** . **R. 1/100 mm, 3 Stellen/Digits** .18 **Toleranz // Tolerance**
Beispielartikelnummer // Example Part number: **U06.0179.030.18 XG**

Fräsen von Sicherungsringnuten, innen

Fräsen von Sicherungsringnuten in Bohrungen ab Bohrungsdurchmesser 18,0 mm. Geeignet für alle Materialien.

Circlip Ring Groove Milling, internal

Circlip ring groove milling in bores as of bore diameter 18,0 mm. For use in all materials.

Schnittwerte (Start) // Cutting parameters (start)		
fzm 0,03 mm	hmax 0,04 mm	Vc Seite/Page 638
Passende Klemmhalter auf Seite // Suitable toolholders on page 529, 530, 531, 532, 533		
Vergleichbare Werkzeuge auf Seite // Similar tools on page 463		
Bitte Hinweise im Anhang beachten // Please read add. notes ALL (Seite/Page 645), H01 (Seite/Page 646), H07 (Seite/Page 648)		

SP Legende
HM Legend

Scan
 Oder besuchen Sie // Or Visit
www.simtek.info/cp/363

Legende Legend **650**

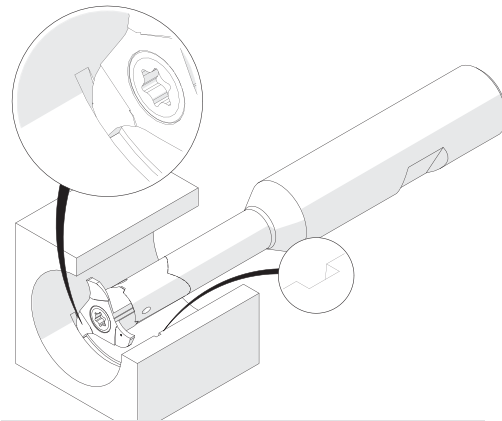
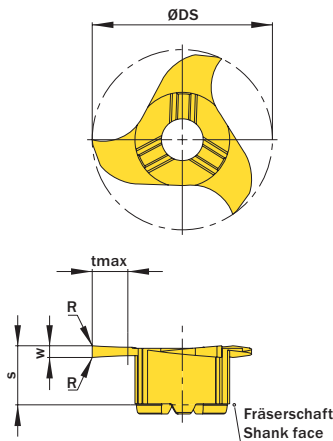


Illustration zeigt beispielhafte Anwendungsmöglichkeit mit ähnlichem Werkzeug.
Image shows exemplary application possibility with similar tool.

Abbildung zeigt / Drawing shows: U18.0110.00 G

w ^{-0,02}	Nuttenbreite Nominal width of groove	R	ØDmin (Min.-Bohrung) ØDmin (min. bore)	Artikelnummer Part number	Webcode www.simtek.com/webcode	Unsere erste Wahl Our first choice	tmax	S	ØDS	ZEFP	Connectcode www.simtek.com/ccode	
mm	mm	mm	mm			P M K N S	mm	mm	mm			upd
0,77	0,7	-	18,0	U18.0070.00 Z	AEX1	X808 HT42	1,5	5,6	17,7	3	UD09.0 UD12.0 UD13.0	upd
0,87	0,8	-	18,0	U18.0080.00 Z	ABTV	X808 HT42	1,7	5,6	17,7	3	UD09.0 UD12.0 UD13.0	upd
0,97	0,9	-	18,0	U18.0090.00 Z	AGH7	X808 HT42	1,9	5,6	17,7	3	UD09.0 UD12.0 UD13.0	upd
1,24	1,1	-	18,0	U18.0110.00 G	AEQD	X808 GT42	3,5	5,8	17,7	3	UD09.0	upd
1,44	1,3	0,1	18,0	U18.0130.01 G	AG1P	X800 GT42	3,5	5,8	17,7	3	UD09.0	upd
1,74	1,6	0,1	18,0	U18.0160.01 G	AKKZ	X800 GT42	3,5	5,8	17,7	3	UD09.0	upd

Bestellbeispiel // Order example: **U18.0110.00 G X800** (X800 = Schneidstoff // Grade)



U18. w, 1/100 mm, 4 Stellen/Digits . R, 1/100 mm, 3 Stellen/Digits Toleranz // Tolerance

Beispielartikelnummer // Example Part number: **U18.0179.030 XG**

simmill AX
simmill PMX
simmill PX
simmill SX
simmill UX
simmill VX
simmill H2
simmill K2
simmill MX
simmill OS
Index

Fräsen von Sicherungsringnuten, innen

Fräsen von Sicherungsringnuten in Bohrungen ab Bohrungsdurchmesser 18,0 mm. Durch hochpositive Schneidengeometrie besonders geeignet für Leichtmetalle.

Circlip Ring Groove Milling, internal

Circlip ring groove milling in bores as of bore diameter 18,0 mm. High positive rake angle for use in light alloys.

Schnittwerte (Start) // Cutting parameters (start)		
fzm 0,03 mm	hmax 0,04 mm	Vc Seite/Page 638

Passende Klemmhalter auf Seite // Suitable toolholders on page
529, 530, 531, 532, 533

Vergleichbare Werkzeuge auf Seite // Similar tools on page
463

Bitte Hinweise im Anhang beachten // Please read add. notes
ALL (Seite/Page 645), H01 (Seite/Page 646), H07 (Seite/Page 648)

SP
HM

LM

Legende
Legend **650**

Scan
QR-Code

Oder besuchen Sie // Or Visit
www.simtek.info/cp/364

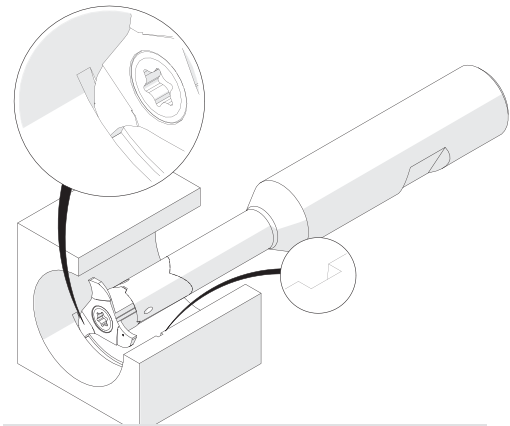
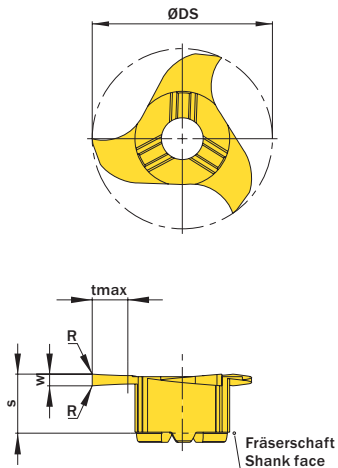


Illustration zeigt beispielhafte Anwendungsmöglichkeit mit ähnlichem Werkzeug.
 Image shows exemplary application possibility with similar tool.

Abbildung zeigt / Drawing shows: U18.0110.40 C

w ^{-0,02}	Nuttenbreite Nominal width of groove	R	ØDmin (Min. Bohrung) ØDmin (min. bore)	Artikelnummer Part number	Webcode www.simtek.com/webcode	Unsere erste Wahl Our first choice	tmax	s	ØDS	ZEFP	Connectcode www.simtek.com/code
mm	mm	mm	mm			P M K N S	mm	mm	mm		
1,24	1,1	-	18,0	U18.0110.40 C	APAJ	X808 HT42	3,5	5,8	17,7	3	UD09.0 <small>upd</small>
1,44	1,3	0,1	18,0	U18.0130.41 C	AG89	X808 HT42	3,5	5,8	17,7	3	UD09.0 <small>upd</small>
1,74	1,6	0,1	18,0	U18.0160.41 C	ANCA	X808 HT42	3,5	5,8	17,7	3	UD09.0 <small>upd</small>

Bestellbeispiel // Order example: **U18.0110.40 C X808** (X808 = Schneidstoff // Grade)



U18. w, 1/100 mm, 4 Stellen/Digits . R, 1/100 mm, 3 Stellen/Digits Toleranz // Tolerance **C**
 Beispielartikelnummer // Example Part number: **U18.0179.030 XG C**

Allgemeines Nutfräsen

Nutfräsen gerader Nutformen.
 Geeignet ab Bohrungsdurchmesser 18,0 mm.

General Groove Milling

General groove milling.
 For use in bores as of minimum bore diameter 18,0 mm.

Schnittwerte (Start) // Cutting parameters (start)		
fzm 0,03 mm	hmax 0,04 mm	Vc Seite/Page 638
Passende Klemmhalter auf Seite // Suitable toolholders on page 529, 530, 531, 532, 533		
Vergleichbare Werkzeuge auf Seite // Similar tools on page 461		
Bitte Hinweise im Anhang beachten // Please read add. notes ALL (Seite/Page 645), H01 (Seite/Page 646), H05 (Seite/Page 648), H07 (Seite/Page 648)		

SP

Legende

HM

Legend

650

Scan QR-Code

Oder besuchen Sie // Or Visit www.simtek.info/cp/362

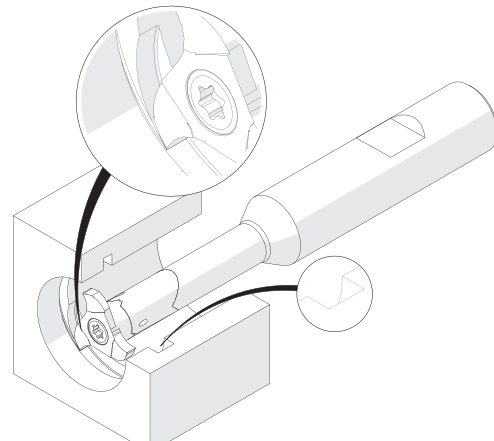
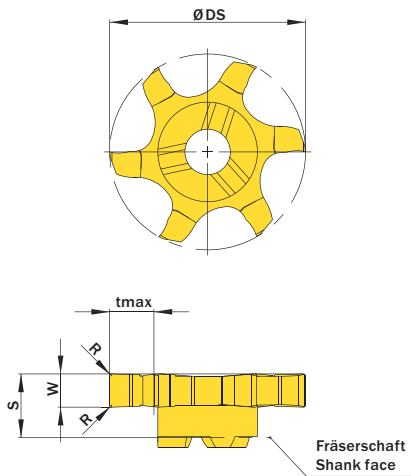


Illustration zeigt beispielhafte Anwendungsmöglichkeit mit ähnlichem Werkzeug.
 Image shows exemplary application possibility with similar tool.

Abbildung zeigt / Drawing shows: U06.0300.020.20 G

w ^{+0,02}	Nutnenbreite Nominal width of groove	R	ØDmin (Min. Bohrung) ØDmin (min. bore)	Artikelnummer Part number	Webcode www.simtek.com/webcode	Unsere erste Wahl Our first choice		tmax	S	ØDS	ZEFP	Connectcode www.simtek.com/ccode
						P M K N S						
1,5	-	0,1	18,0	U06.0150.010.18 G	AN3P	X800	GT42	4,0	5,8	17,7	6	UD09.0
2,0	-	0,2	18,0	U06.0200.020.18 G	AD6K	X800	GT42	4,0	5,8	17,7	6	UD09.0
2,5	-	0,2	18,0	U06.0250.020.18 G	AB6C	X800	GT42	4,0	5,8	17,7	6	UD09.0
3,0	-	0,2	18,0	U06.0300.020.18 G	AE37	X800	GT42	4,0	5,8	17,7	6	UD09.0

Bestellbeispiel // Order example: **U06.0300.020.18 G X800** (X800 = Schneidstoff // Grade)



U06. w, 1/100 mm, 4 Stellen/Digits . R, 1/100 mm, 3 Stellen/Digits .18 Toleranz // Tolerance
 Beispielpartikelnummer // Example Part number: **U06.0179.030.18 XG**

simmill AX
simmill PMX
simmill PX
simmill SX
simmill UX
simmill VX
simmill H2
simmill K2
simmill MX
simmill OS
Index

Allgemeines Nutfräsen

Nutfräsen gerader Nutformen.
 Geeignet ab Bohrungsdurchmesser 20,0 mm.

General Groove Milling

General groove milling.
 For use in bores as of minimum bore diameter 20,0 mm.

Schnittwerte (Start) // Cutting parameters (start)		
fzm	hmax	Vc
0,03 mm	0,04 mm	Seite/Page 638

Passende Klemmhalter auf Seite // Suitable toolholders on page
529, 530, 531, 532, 533

Vergleichbare Werkzeuge auf Seite // Similar tools on page
461

Bitte Hinweise im Anhang beachten // Please read add. notes

ALL (Seite/Page 645), H01 (Seite/Page 646), H05 (Seite/Page 648), H07 (Seite/Page 648)

SP

HM

Legende
Legend

650

Scan
QR-Code

Oder besuchen Sie // Or Visit
www.simtek.info/cp/369

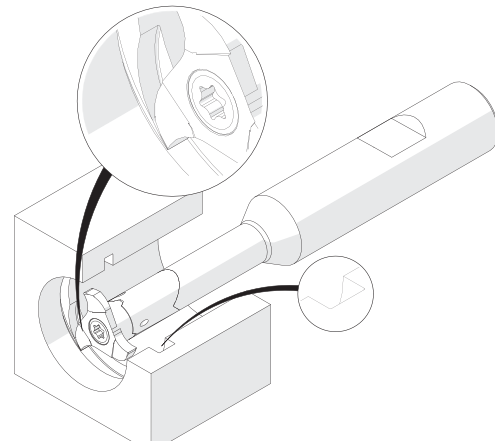
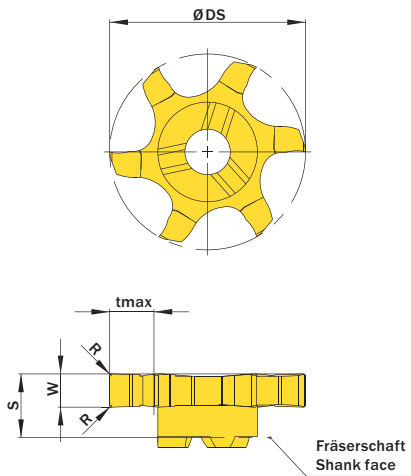


Illustration zeigt beispielhafte Anwendungsmöglichkeit mit ähnlichem Werkzeug.
 Image shows exemplary application possibility with similar tool.

Abbildung zeigt / Drawing shows: U06.0300.020.20 G

w ^{+0,02}	Nuttenbreite Nominal width of groove	R	ØDmin (Min.-Bohrung) ØDmin (min. bore)	Artikelnummer Part number	Webcode www.simtek.com/webcode	Unsere erste Wahl Our first choice	tmax	S	ØDS	ZEFP	Connectcode www.simtek.com/ccode
mm	mm	mm	mm			P M K N S	mm	mm	mm		
1,5	-	0,1	20,0	U06.0150.010.20 G	AGE9	X800 GT42	5,0	5,8	19,7	6	UD09.0
2,0	-	0,2	20,0	U06.0200.020.20 G	AJ2T	X800 GT42	5,0	5,8	19,7	6	UD09.0
2,5	-	0,2	20,0	U06.0250.020.20 G	ANY1	X800 GT42	5,0	5,8	19,7	6	UD09.0
3,0	-	0,2	20,0	U06.0300.020.20 G	ACAZ	X800 GT42	5,0	5,8	19,7	6	UD09.0

Bestellbeispiel // Order example: **U06.0300.020.20 G X800** (X800 = Schneidstoff // Grade)



U06. w, 1/100 mm, 4 Stellen/Digits . R, 1/100 mm, 3 Stellen/Digits .20 Toleranz // Tolerance
 Beispielpartikelnummer // Example Part number: **U06.0179.030.20 XG**

Allgemeines Nutfräsen

Nutfräsen gerader Nutformen.
 Geeignet ab Bohrungsdurchmesser 18,0 mm.

General Groove Milling

General groove milling.
 For use in bores as of minimum bore diameter 18,0 mm.

Schnittwerte (Start) // Cutting parameters (start)		
f _{zm} 0,03 mm	h _{max} 0,04 mm	V _c Seite/Page 638
Passende Klemmhalter auf Seite // Suitable toolholders on page 529, 530, 531, 532, 533		
Vergleichbare Werkzeuge auf Seite // Similar tools on page 461		
Bitte Hinweise im Anhang beachten // Please read add. notes ALL (Seite/Page 645), H01 (Seite/Page 646), H07 (Seite/Page 648)		

SP Legende
HM Legend

Scan
 Oder besuchen Sie // Or Visit
www.simtek.info/cp/361

Legende Legend **650**

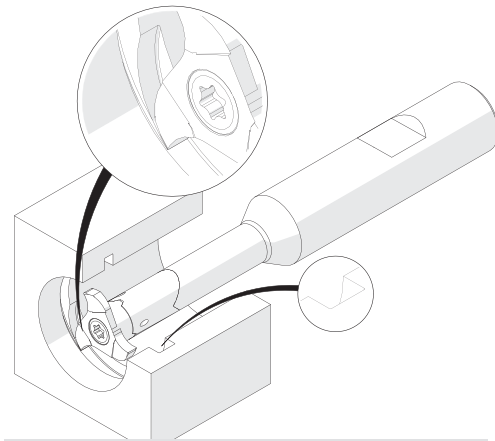
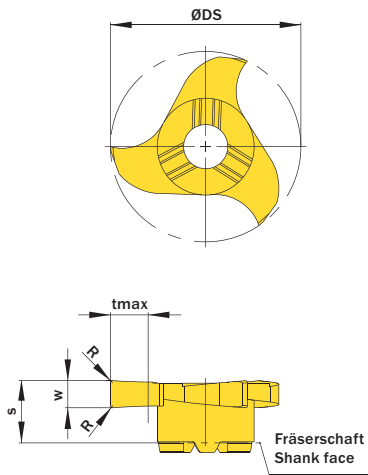


Illustration zeigt beispielhafte Anwendungsmöglichkeit mit ähnlichem Werkzeug.
 Image shows exemplary application possibility with similar tool.

Abbildung zeigt / Drawing shows: U18.0250.02 G

w ^{+0,02}	Nuttenbreite Nominal width of groove	R	ØDmin (Min.-Bohrung) ØDmin (min. bore)	Artikelnummer Part number	Webcode www.simtek.com/webcode	Unsere erste Wahl Our first choice		tmax	S	ØDS	ZEFP	Connectcode www.simtek.com/ccode	
						P M K N S							
1,168	-	-	18,0	U18.0117.00 G	AAU0	X800	GT42	3,5	5,8	17,7	3	UD09.0	inch
1,422	-	-	18,0	U18.0142.00 G	ANB1	X800	GT42	3,5	5,8	17,7	3	UD09.0	inch
1,5	-	0,2	18,0	U18.0150.02 G	AMW2	X800	GT42	3,5	5,8	17,7	3	UD09.0	
1,549	-	0,2	18,0	U18.0157.02 G	AJ80	X800	GT42	3,5	5,8	17,7	3	UD09.0	inch
2,0	-	0,2	18,0	U18.0200.02 G	AJXK	X800	GT42	3,5	5,8	17,7	3	UD09.0	
2,388	-	0,2	18,0	U18.0239.02 G	AG6E	X800	GT42	3,5	5,8	17,7	3	UD09.0	inch
2,5	-	0,2	18,0	U18.0250.02 G	ABXH	X800	GT42	3,5	5,8	17,7	3	UD09.0	
3,0	-	0,2	18,0	U18.0300.02 G	ADJZ	X800	GT42	3,5	5,8	17,7	3	UD09.0	
3,175	-	0,2	18,0	U18.0318.02 G	AJZU	X800	GT42	3,5	5,8	17,7	3	UD09.0	inch
4,0	-	0,2	18,0	U18.0400.02 G	AJUU	X800	GT42	3,5	5,8	17,7	3	UD09.0	

Bestellbeispiel // Order example: **U18.0300.02 G X800** (X800 = Schneidstoff // Grade)



U18. w, 1/100 mm, 4 Stellen/Digits . R, 1/100 mm, 3 Stellen/Digits Toleranz // Tolerance

Beispielartikelnummer // Example Part number: **U18.0179.030 XG**

simmill AX
simmill PMX
simmill PX
simmill SX
simmill UX
simmill VX
simmill H2
simmill K2
simmill MX
simmill OS
Index

Allgemeines Nutfräsen

Nutfräsen gerader Nutformen.
 Geeignet ab Bohrungsdurchmesser 20,0 mm.

General Groove Milling

General groove milling.
 For use in bores as of minimum bore diameter 20,0 mm.

Schnittwerte (Start) // Cutting parameters (start)		
f _{zm} 0,03 mm	h _{max} 0,04 mm	V _c Seite/Page 638

Passende Klemmhalter auf Seite // Suitable toolholders on page
529, 530, 531, 532, 533

Vergleichbare Werkzeuge auf Seite // Similar tools on page
461

Bitte Hinweise im Anhang beachten // Please read add. notes
ALL (Seite/Page 645), H01 (Seite/Page 646), H07 (Seite/Page 648)

SP Legende

HM Legend

650

Scan QR-Code

Oder besuchen Sie // Or Visit www.simtek.info/cp/1150

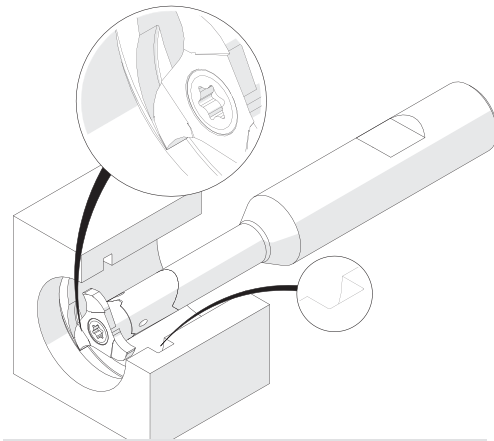
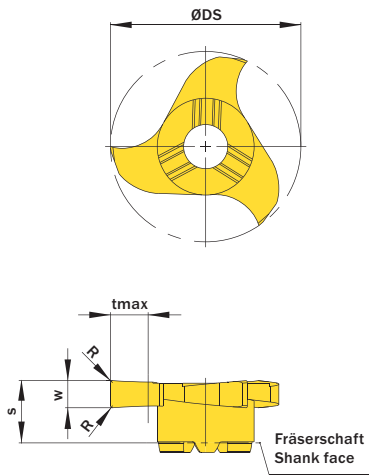


Illustration zeigt beispielhafte Anwendungsmöglichkeit mit ähnlichem Werkzeug.
 Image shows exemplary application possibility with similar tool.

Abbildung zeigt / Drawing shows: U18.0250.02 G

w ^{+0,02}	Nuttenbreite Nominal width of groove	R	ØDmin (Min. Bohrung) ØDmin (min. bore)	Artikelnummer Part number	Webcode www.simtek.com/webcode	Unsere erste Wahl Our first choice	tmax	S	ØDS	ZEFP	Connectcode www.simtek.com/ccode
mm	mm	mm	mm			P M K N S	mm	mm	mm		
1,5	-	0,2	20,0	U20.0150.02 G	AX11	X800 GT42	4,5	5,8	19,7	3	UD09.0
2,0	-	0,2	20,0	U20.0200.02 G	AX13	X800 GT42	4,5	5,8	19,7	3	UD09.0
2,5	-	0,2	20,0	U20.0250.02 G	AX12	X800 GT42	4,5	5,8	19,7	3	UD09.0

Bestellbeispiel // Order example: **U20.0250.02 G X800** (X800 = Schneidstoff // Grade)

Allgemeines Nutfräsen, für weiche Schnitte

Nutfräsen gerader Nutformen. Weiches Eintauchen in den Werkstückstoff und bessere Oberflächen durch optimierte Schneidengeometrie. Geeignet ab Bohrungsdurchmesser 18,0 mm.

General Groove Milling, for smooth cuts

General groove milling. With a new cutting edge geometry for very smooth cuts and better surface quality. For use in bores as of minimum bore diameter 18,0 mm.

Schnittwerte (Start) // Cutting parameters (start)		
fzm 0,03 mm	hmax 0,04 mm	Vc Seite/Page 638
Passende Klemmhalter auf Seite // Suitable toolholders on page		
529, 530, 531, 532, 533		
Vergleichbare Werkzeuge auf Seite // Similar tools on page		
461		
Bitte Hinweise im Anhang beachten // Please read add. notes		
ALL (Seite/Page 645), H01 (Seite/Page 646), H05 (Seite/Page 648), H07 (Seite/Page 648)		

SP

Legende
Legend

HM

Legende
Legend

650

Scan QR-Code

Oder besuchen Sie // Or Visit www.simtek.info/cp/1123

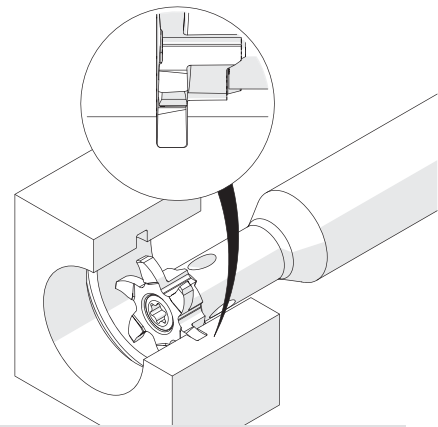
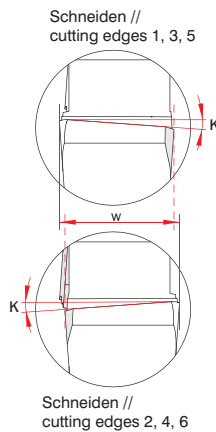
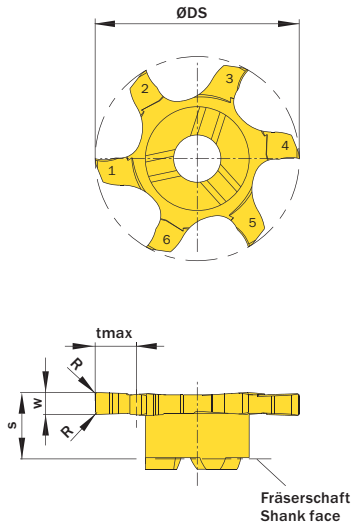


Illustration zeigt beispielhafte Anwendungsmöglichkeit mit ähnlichem Werkzeug.
 Image shows exemplary application possibility with similar tool.

Abbildung zeigt / Drawing shows: U06.0250.020.18 GY

w ^{+0,02}	Nuttenbreite Nominal width of groove	R	ØDmin (Min. Bohrung) ØDmin (min. bore)	Artikelnummer Part number	Webcode www.simtek.com/webcode	Unsere erste Wahl Our first choice		tmax	S	ØDS	ZEFP	Connectcode www.simtek.com/ccode
						P M K N S						
2,0	-	0,2	18,0	U06.0200.020.18 GY	AYFP	X800	GT42	4,0	5,8	17,7	6	UD09.0
2,5	-	0,2	18,0	U06.0250.020.18 GY	AYFS	X800	GT42	4,0	5,8	17,7	6	UD09.0
3,0	-	0,2	18,0	U06.0300.020.18 GY	AYFT	X800	GT42	4,0	5,8	17,7	6	UD09.0

Bestellbeispiel // Order example: **U06.0300.020.18 GY X800** (X800 = Schneidstoff // Grade)

Allgemeines Nutfräsen, für weiche Schnitte

Nutfräsen gerader Nutformen. Weiches Eintauchen in den Werkstückstoff und bessere Oberflächen durch optimierte Schneidengeometrie. Geeignet ab Bohrungsdurchmesser 20,0 mm.

General Groove Milling, for smooth cuts

General groove milling. With a new cutting edge geometry for very smooth cuts and better surface quality. For use in bores as of minimum bore diameter 20,0 mm.

Schnittwerte (Start) // Cutting parameters (start)		
fzm 0,03 mm	hmax 0,04 mm	Vc Seite/Page 638

Passende Klemmhalter auf Seite // Suitable toolholders on page **529, 530, 531, 532, 533**

Vergleichbare Werkzeuge auf Seite // Similar tools on page **461**

Bitte Hinweise im Anhang beachten // Please read add. notes

ALL (Seite/Page 645), H01 (Seite/Page 646), H05 (Seite/Page 648), H07 (Seite/Page 648)



SP Legende
HM Legend
650

Scan QR-Code Oder besuchen Sie // Or Visit www.simtek.info/cp/1134

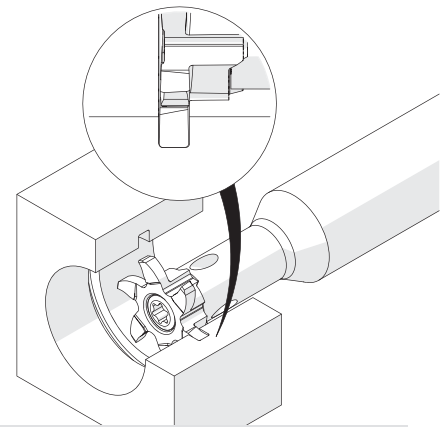
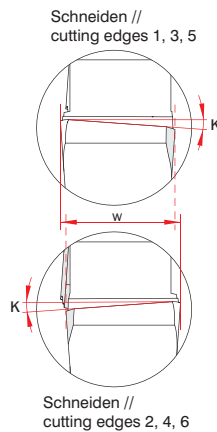
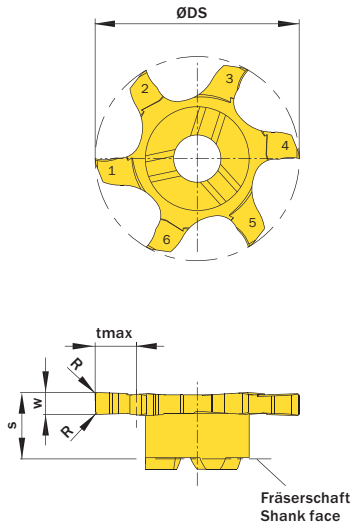


Illustration zeigt beispielhafte Anwendungsmöglichkeit mit ähnlichem Werkzeug.
 Image shows exemplary application possibility with similar tool.

Abbildung zeigt / Drawing shows: U06.0250.020.18 GY

w ^{+0,02}	Nuttenbreite Nominal width of groove	R	ØDmin (Min. Bohrung) ØDmin (min. bore)	Artikelnummer Part number	Webcode www.simtek.com/webcode	Unsere erste Wahl Our first choice	tmax	S	ØDS	ZEFP	Connectcode www.simtek.com/ccode
mm	mm	mm	mm			P M K N S	mm	mm	mm		
2,0	-	0,2	20,0	U06.0200.020.20 GY	AYFW	X800 GT42	5,0	5,8	19,7	6	UD09.0
2,5	-	0,2	20,0	U06.0250.020.20 GY	AYFV	X800 GT42	5,0	5,8	19,7	6	UD09.0
3,0	-	0,2	20,0	U06.0300.020.20 GY	AYFU	X800 GT42	5,0	5,8	19,7	6	UD09.0

Bestellbeispiel // Order example: **U06.0300.020.20 GY X800** (X800 = Schneidstoff // Grade)

Allgemeines Nutfräsen in Leichtmetall

Nutfräsen gerader Nutformen in Bohrungen ab Bohrungsdurchmesser 18,0 mm. Durch hochpositive Schneidengeometrie besonders geeignet für Leichtmetalle.

General Groove Milling in light alloys

General groove milling in bores as of bore diameter 18,0 mm. High positive rake angle for use in light alloys.

Schnittwerte (Start) // Cutting parameters (start)		
fzm 0,03 mm	hmax 0,04 mm	Vc Seite/Page 638
Passende Klemmhalter auf Seite // Suitable toolholders on page 529, 530, 531, 532, 533		
Vergleichbare Werkzeuge auf Seite // Similar tools on page 462		
Bitte Hinweise im Anhang beachten // Please read add. notes ALL (Seite/Page 645), H01 (Seite/Page 646), H07 (Seite/Page 648)		

SP

HM

LM

Legende Legend **650**

Scan QR-Code Oder besuchen Sie // Or Visit www.simtek.info/cp/370

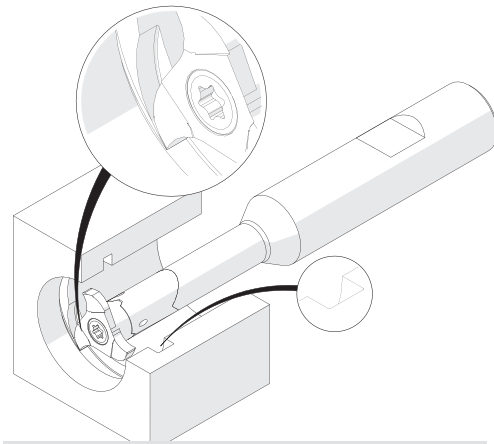
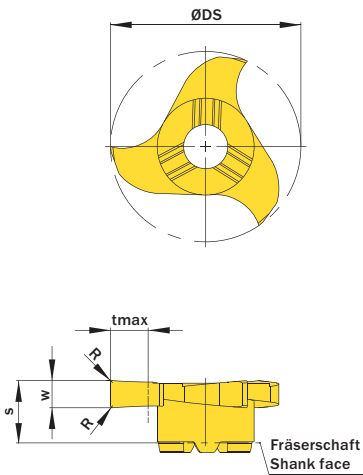


Illustration zeigt beispielhafte Anwendungsmöglichkeit mit ähnlichem Werkzeug. Image shows exemplary application possibility with similar tool.

Abbildung zeigt / Drawing shows: U18.0250.42 C

w ^{+0,02} mm	Nuttenbreite Nominal width of groove mm	R mm	ØDmin (Min. Bohrung) ØDmin (min. bore) mm	Artikelnummer Part number	Webcode www.simtek.com/webcode	Unsere erste Wahl Our first choice		tmax mm	S mm	ØDS mm	ZEFP	Connectcode www.simtek.com/ccode
						P M K N S	X808 HT42					
1,5	-	0,2	18,0	U18.0150.42 C	ANJ3	X808	HT42	3,5	5,8	17,7	3	UD09.0
2,0	-	0,2	18,0	U18.0200.42 C	AH68	X808	HT42	3,5	5,8	17,7	3	UD09.0
2,5	-	0,2	18,0	U18.0250.42 C	ANED	X808	HT42	3,5	5,8	17,7	3	UD09.0
3,0	-	0,2	18,0	U18.0300.42 C	AJ6H	X808	HT42	3,5	5,8	17,7	3	UD09.0

Bestellbeispiel // Order example: **U18.0200.42 C HF25** (HF25 = Schneidstoff // Grade)



U18. w, 1/100 mm, 4 Stellen/Digits . R, 1/100 mm, 3 Stellen/Digits Toleranz // Tolerance C
 Beispielartikelnummer // Example Part number: **U18.0179.030 XG C**

simmill AX
simmill PMX
simmill PX
simmill SX
simmill UX
simmill VX
simmill H2
simmill K2
simmill MX
simmill OS
Index

Fräsen von Vollradiusnuten

Nutfräsen runder Nutformen.
 Geeignet ab Bohrungsdurchmesser 18,0 mm.

Full Radius Groove Milling

Full radius groove milling.
 For use in bores as of minimum bore diameter 18,0 mm.

Schnittwerte (Start) // Cutting parameters (start)

f _{zm} 0,03 mm	h _{max} 0,04 mm	V _c Seite/Page 638
-----------------------------------	------------------------------------	---

Passende Klemmhalter auf Seite // Suitable toolholders on page
529, 530, 531, 532, 533

Vergleichbare Werkzeuge auf Seite // Similar tools on page
465

Bitte Hinweise im Anhang beachten // Please read add. notes

ALL (Seite/Page 645), H01 (Seite/Page 646), H07 (Seite/Page 648)



SP Legende
HM Legend
650

Scan QR-Code Oder besuchen Sie // Or Visit
www.simtek.info/cp/402

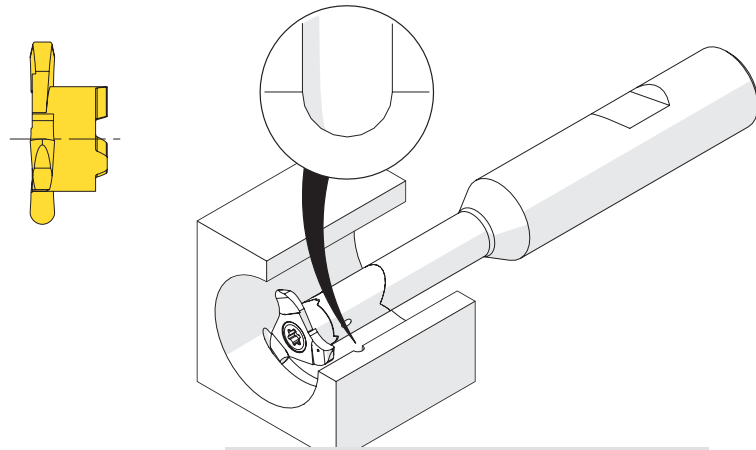
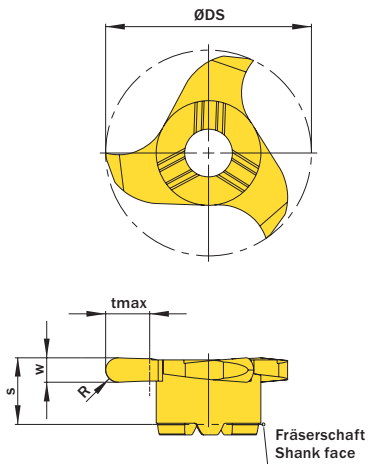


Illustration zeigt beispielhafte Anwendungsmöglichkeit mit ähnlichem Werkzeug.
 Image shows exemplary application possibility with similar tool.

Abbildung zeigt / Drawing shows: U18.0011.22 V

R	w ^{+0,03}	ØDmin (Min. Bohrung) ØDmin (min. bore)	Artikelnummer Part number	Webcode www.simtek.com/webcode	Unsere erste Wahl Our first choice	tmax	S	ØDS	ZEFP	Connectcode www.simtek.com/code
mm	mm	mm			P M K N S	mm	mm	mm		
1,0	2,0	18,0	U18.0010.20 V	AAKM	X800 GT42	3,5	5,8	17,7	3	UD09.0
1,1	2,2	18,0	U18.0011.22 V	AM4F	X800 GT42	3,5	5,8	17,7	3	UD09.0
1,19	2,38	18,0	U18.0012.24 V	A1J5	X800 GT42	3,5	5,8	17,7	3	UD09.0
1,5	3,0	18,0	U18.0015.30 V	AEDU	X800 GT42	3,5	5,8	17,7	3	UD09.0

Bestellbeispiel // Order example: **U18.0015.30 V X800** (X800 = Schneidstoff // Grade)

Metrisches ISO-Gewindefräsen, Vollprofil

Fräsen von metrischen ISO-Gewinden, Vollprofil.

Thread milling, metric ISO-Thread, full profile

Thread milling of metric ISO-thread, full profile.

Schnittwerte (Start) // Cutting parameters (start)		
f _{zm} 0,03 mm	h _{max} 0,04 mm	V _c Seite/Page 638
Passende Klemmhalter auf Seite // Suitable toolholders on page 529, 530, 531, 532, 533		
Vergleichbare Werkzeuge auf Seite // Similar tools on page 467		
Bitte Hinweise im Anhang beachten // Please read add. notes ALL (Seite/Page 645), H03 (Seite/Page 647), H05 (Seite/Page 648), H06 (Seite/Page 648), H07 (S./P. 648)		

SP Legende

HM Legend

Scan QR-Code

650

Oder besuchen Sie // Or Visit
www.simtek.info/cp/876

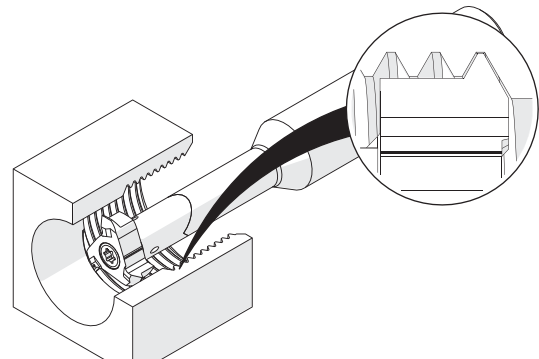
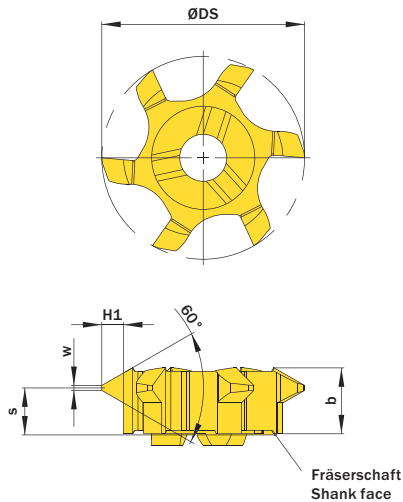


Illustration zeigt beispielhafte Anwendungsmöglichkeit mit ähnlichem Werkzeug.
 Image shows exemplary application possibility with similar tool.

Abbildung zeigt / Drawing shows: U06.1835.02.18 M

Ab Gewindegroße As of thread size	Ab Gewindegrenndurchmesser // As of nominal thread diameter	Steigung (von) Pitch (as of)	Artikelnummer Part number	Webcode www.simtek.com/webcode	Unsere erste Wahl Our first choice		b	S	H1	ØDS	w	ZEFP	Connectcode www.simtek.com/ccode	
					PM	KN								
M22	21,74	1,5	U06.0815.02.18 M	ASZ9	X800	GT42	5,85	5,1	0,81	17,7	0,19	6	UD09.0 UD12.0 UD13.0	upd
M27	24,15	2,0	U06.1020.02.18 M	AS0G	X800	GT42	5,85	4,8	1,08	17,7	0,25	6	UD09.0 UD12.0 UD13.0	upd
M27	26,5	3,0	U06.1630.02.18 M	AS0J	X800	GT42	5,85	4,6	1,62	17,7	0,38	6	UD09.0 UD12.0 UD13.0	upd
M30	27,6	3,5	U06.1835.02.18 M	AS0H	X800	GT42	5,85	4,1	1,89	17,7	0,44	6	UD09.0 UD12.0 UD13.0	upd

Bestellbeispiel // Order example: **U06.0815.02.18 M X800** (X800 = Schneidstoff // Grade)

simmill AX
simmill PMX
simmill PX
simmill SX
simmill UX
simmill VX
simmill H2
simmill K2
simmill MX
simmill OS
Index

Metrisches ISO-Gewindefräsen, Vollprofil

Fräsen von metrischen ISO-Gewinden, Vollprofil.

Thread milling, metric ISO-Thread, full profile

Thread milling of metric ISO-threads, full profile.

Schnittwerte (Start) // Cutting parameters (start)

fzm 0,03 mm	hmax 0,04 mm	Vc Seite/Page 638
-----------------------	------------------------	-----------------------------

Passende Klemmhalter auf Seite // Suitable toolholders on page
529, 530, 531, 532, 533

Vergleichbare Werkzeuge auf Seite // Similar tools on page
467

Bitte Hinweise im Anhang beachten // Please read add. notes

**ALL (Seite/Page 645), H03 (Seite/Page 647),
 H06 (Seite/Page 648), H07 (Seite/Page 648)**



SP Legende
HM Legend
650

Scan QR-Code Oder besuchen Sie // Or Visit
www.simtek.info/cp/415

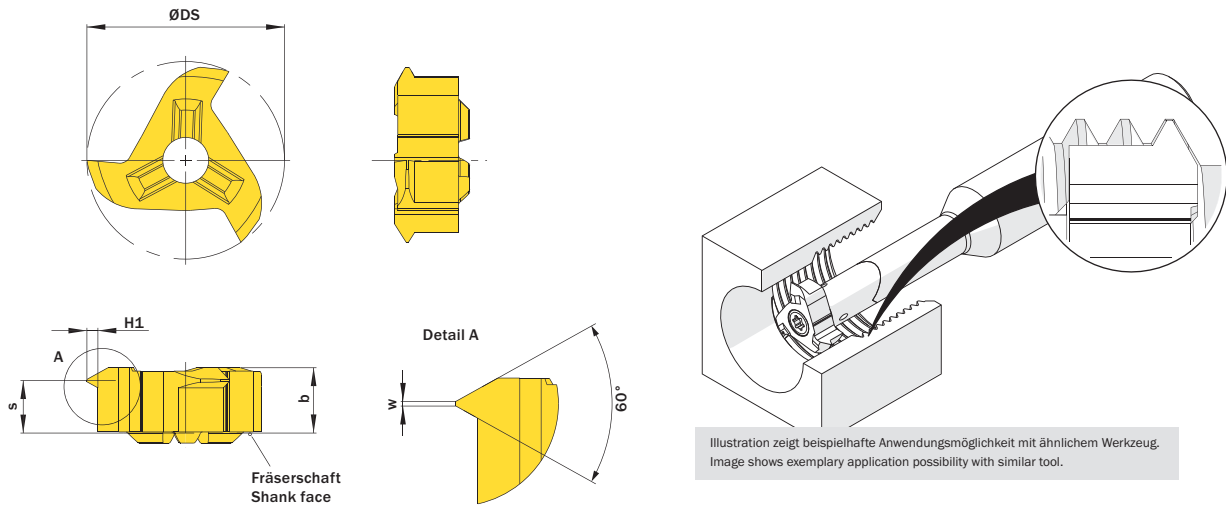


Illustration zeigt beispielhafte Anwendungsmöglichkeit mit ähnlichem Werkzeug.
 Image shows exemplary application possibility with similar tool.

Abbildung zeigt / Drawing shows: U18.0917.02 M

Ab Gewindegroße As of thread size	Ab Gewindegroße As of nominal thread diameter		Steigung (von) Pitch (as of)	Artikelnummer Part number	Webcode www.simtek.com/webcode	Unsere erste Wahl Our first choice		b	S	w	ØDS	ZEFP	Connectcode www.simtek.com/ccode			
	mm	H1				P	M						K	N	S	UD09.0
M22	21,74	0,81	1,5	U18.0815.02 M	AHK3	X800	G742	5,85	4,8	0,18	17,7	3	UD09.0	UD12.0	UD13.0	upd
M24	22,91	0,95	1,75	U18.0917.02 M	AK07	X800	G742	5,85	4,7	0,21	17,7	3	UD09.0	UD12.0	UD13.0	upd
M27	24,15	1,08	2,0	U18.1020.02 M	AE0E	X800	G742	5,85	4,6	0,25	17,7	3	UD09.0	UD12.0	UD13.0	upd
M27	25,4	1,35	2,5	U18.1325.02 M	AJY6	X800	G742	5,85	4,4	0,31	17,7	3	UD09.0	UD12.0	UD13.0	upd
M27	26,5	1,62	3,0	U18.1630.02 M	AJYF	X800	G742	5,85	4,3	0,37	17,7	3	UD09.0	UD12.0	UD13.0	upd
M30	27,6	1,9	3,5	U18.1835.02 M	AN9W	X800	G742	5,85	4,0	0,43	17,7	3	UD09.0	UD12.0	UD13.0	upd

Bestellbeispiel // Order example: **U18.1630.02 M X800** (X800 = Schneidstoff // Grade)

simmill AX

simmill PMX

simmill PX

simmill SX

simmill UX

simmill VX

simmill H2

simmill K2

simmill MX

simmill OS

Index

Metrisches ISO-Gewindfräsen, Teilprofil

Ausgelegt als Mehrbereichswerkzeuge. Die angegebene „Steigung (von)“ ist normgerecht. Die „Steigung (bis)“ kann ebenfalls realisiert werden. Vgl. Hinweistexte.

Thread milling, metric ISO-Thread, partial profile

Multi-purpose milling inserts. The given „Pitch (as of)“ is conforming to standards. The „Pitch (up to)“ is possible too at the expense of conformity. Please read additional notes.

Schnittwerte (Start) // Cutting parameters (start)		
fzm 0,03 mm	hmax 0,04 mm	Vc Seite/Page 638
Passende Klemmhalter auf Seite // Suitable toolholders on page 529, 530, 531, 532, 533		
Vergleichbare Werkzeuge auf Seite // Similar tools on page 466		
Bitte Hinweise im Anhang beachten // Please read add. notes ALL (Seite/Page 645), H03 (Seite/Page 647), H04 (Seite/Page 648), H05 (Seite/Page 648), H07 (S./P. 648)		

SP Legende
Legend

HM Legende
Legend

650

Scan QR-Code Oder besuchen Sie // Or Visit
www.simtek.info/cp/394

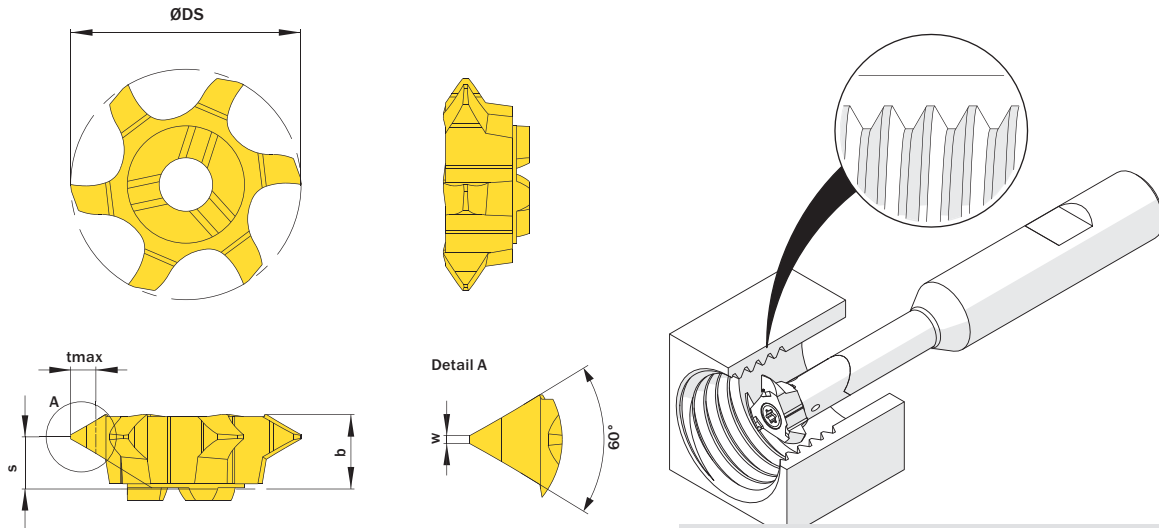


Abbildung zeigt / Drawing shows: U06.2535.01.18 M

Illustration zeigt beispielhafte Anwendungsmöglichkeit mit ähnlichem Werkzeug.
 Image shows exemplary application possibility with similar tool.

Ab Gewindegröße As of thread size	Steigung (von) Pitch (as of)	Steigung (bis) Pitch (up to)	Artikelnummer Part number	Webcode www.simtek.com/webcode	Unsere erste Wahl Our first choice		b	S	w	tmax	ØDS	ZEFP	Connectcode www.simtek.com/ccode
					P	M							
M22	1,0	2,0	U06.0720.01.18 M	AE99	X800	GT42	5,85	4,6	0,12	1,19	17,7	6	UD09.0 UD12.0 UD13.0
M24	2,0	4,0	U06.2535.01.18 M	APNP	X800	GT42	5,85	4,0	0,25	2,57	17,7	6	UD09.0 UD12.0 upd

Bestellbeispiel // Order example: **U06.2535.01.18 M X800** (X800 = Schneidstoff // Grade)

- Bitte beachten Sie die zusätzlichen Hinweise zu den Mehrbereichswerkzeugen im Infobereich rechts oben.
 Please read the additional notes mentioned in the information area on the top right corner of this page.
- Die angegebene GewindegröÙeneignung bezieht sich auf die Startsteigung.
 The mentioned thread size „As of thread size“ is based on the starting pitch.

Mehr Infos zu den **Mehrbereichswerkzeugen** und deren **GewindegröÙeneignung** finden Sie auf Seite 649

More information about the **multi-purpose thread milling tools** and the **thread size suitability** can be found on page 649

Metrisches ISO-Gewindefräsen, Teilprofil

Ausgelegt als Mehrbereichswerkzeuge. Die angegebene „Steigung (von)“ ist normgerecht. Die „Steigung (bis)“ kann ebenfalls realisiert werden. Vgl. Hinweistexte.

Thread milling, metric ISO-Thread, partial profile

Multi-purpose milling inserts. The given „Pitch (as of)“ is conforming to standards. The „Pitch (up to)“ is possible too at the expense of conformity. Please read additional notes.

Schnittwerte (Start) // Cutting parameters (start)

fzm 0,03 mm	hmax 0,04 mm	Vc Seite/Page 638
-----------------------	------------------------	-----------------------------

Passende Klemmhalter auf Seite // Suitable toolholders on page
529, 530, 531, 532, 533

Vergleichbare Werkzeuge auf Seite // Similar tools on page
466

Bitte Hinweise im Anhang beachten // Please read add. notes
ALL (Seite/Page 645), H02 (Seite/Page 646), H03 (Seite/Page 647), H04 (Seite/Page 648), H07 (S./P. 648)

SP

Legende

650

HM

Legende

Scan QR-Code

Oder besuchen Sie // Or Visit www.simtek.info/cp/395

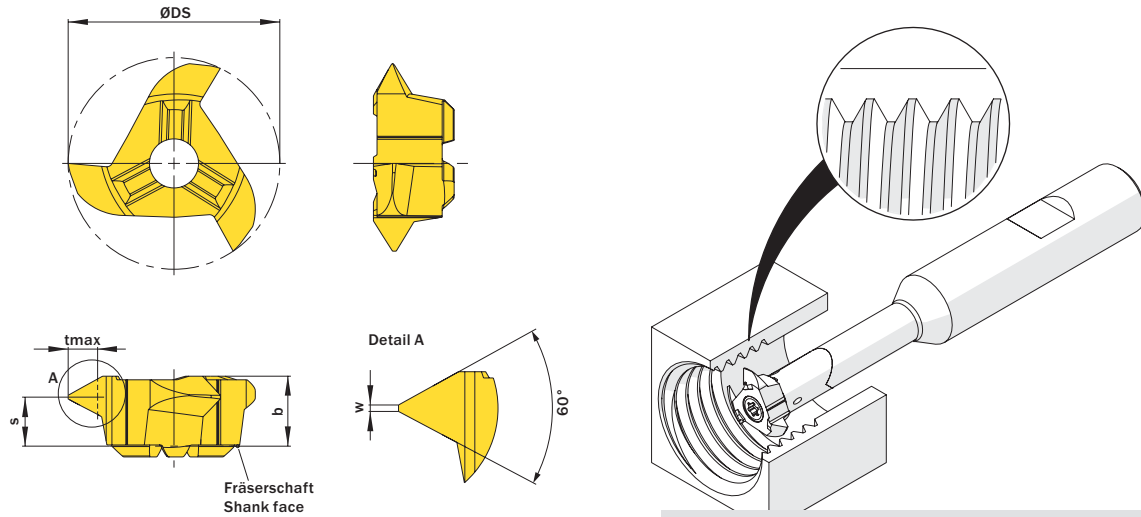


Illustration zeigt beispielhafte Anwendungsmöglichkeit mit ähnlichem Werkzeug. Image shows exemplary application possibility with similar tool.

Abbildung zeigt / Drawing shows: U18.2535.01 M

Ab Gewindegroße As of thread size	Steigung (von) Pitch (as of)	Steigung (bis) Pitch (up to)	Artikelnummer Part number	Webcode www.simtek.com/webcode	Unsere erste Wahl Our first choice		b	S	w	tmax	ØDS	ZEFP	Connectcode www.simtek.com/ccode
					P	M							
M22	1,0	1,75	U18.0510.01 M	ADHC	X800	GT42	5,85	5,0	0,12	1,03	17,7	3	UD09.0 UD12.0 UD13.0
M22	1,0	2,0	U18.0720.01 M	AA8M	X800	GT42	5,85	4,7	0,12	1,19	17,7	3	UD09.0 UD12.0 UD13.0
M22	1,5	2,75	U18.0815.01 M	AM2Q	X800	GT42	5,85	4,6	0,19	1,62	17,7	3	UD09.0 UD12.0 UD13.0
M24	2,0	3,75	U18.1020.01 M	AN1S	X800	GT42	5,85	4,2	0,25	2,22	17,7	3	UD09.0 UD12.0 UD13.0
M24	2,0	3,0	U18.1325.01 M	AAUQ	X800	GT42	5,85	4,4	0,25	1,73	17,7	3	UD09.0 UD12.0 UD13.0
M24	2,5	5,0	U18.1630.01 M	AH9G	X800	GT42	5,85	3,8	0,31	2,98	17,7	3	UD09.0
M24	3,0	5,5	U18.1835.01 M	ADW6	X800	GT42	5,85	3,6	0,38	3,25	17,7	3	UD09.0
M24	2,0	4,0	U18.2535.01 M	APT V	X800	GT42	5,85	4,2	0,25	2,57	17,7	3	UD09.0 UD12.0

Bestellbeispiel // Order example: **U18.1630.01 M X800** (X800 = Schneidstoff // Grade)

Bitte beachten Sie die zusätzlichen Hinweise zu den Mehrbereichswerkzeugen im Infobereich rechts oben.
 Please read the additional notes mentioned in the information area on the top right corner of this page.

Die angegebene Gewindegroßeignung bezieht sich auf die Startsteigung.
 The mentioned thread size „As of thread size“ is based on the starting pitch.

Mehr Infos zu den **Mehrbereichswerkzeugen** und deren **Gewindegroßeignung** finden Sie auf Seite 649

More information about the **multi-purpose thread milling tools** and the **thread size suitability** can be found on page 649

UN-Gewindefräsen, Vollprofil

Fräsen von UN-Gewinden, Vollprofil.

Thread milling, UN Full Profile

Thread milling of UN-threads, full profile.

Schnittwerte (Start) // Cutting parameters (start)

fzm	hmax	Vc
0,03 mm	0,04 mm	Seite/Page 638

Passende Klemmhalter auf Seite // Suitable toolholders on page
529, 530, 531, 532, 533

Bitte Hinweise im Anhang beachten // Please read add. notes

ALL (Seite/Page 645), H03 (Seite/Page 647), H05 (Seite/Page 648), H07 (Seite/Page 648)



SP Legende
HM Legend
650

Scan QR-Code Oder besuchen Sie // Or Visit
www.simtek.info/cp/877

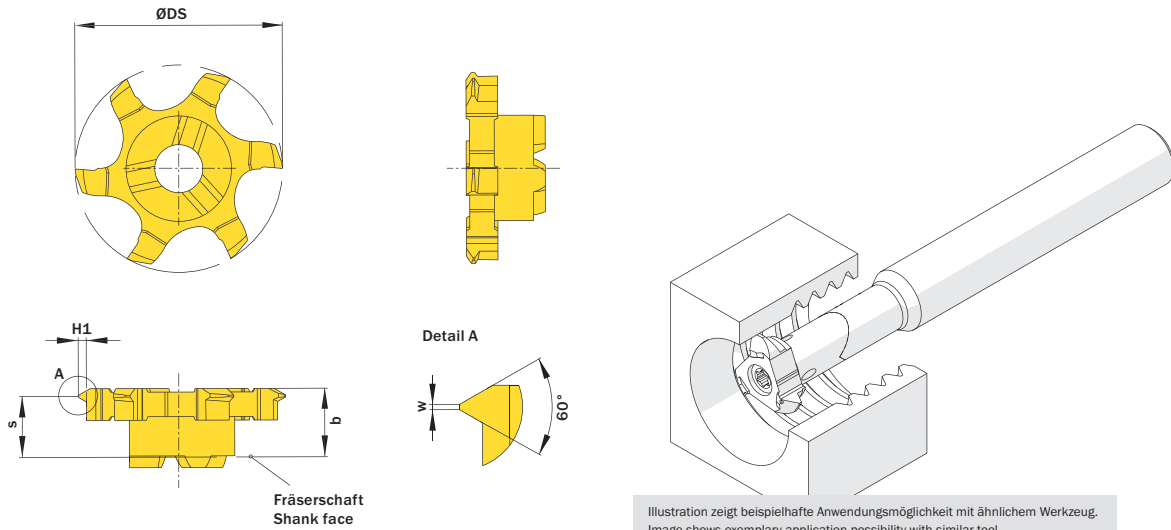


Abbildung zeigt / Drawing shows: U06.UN20.02.18 M

Gang/Zoll Threads/inch	Artikelnummer Part number	Webcode www.simtek.com/webcode	Unsere erste Wahl Our first choice		b	H1	S	ØDS	w	ZEFP	Connectcode www.simtek.com/ccode
			P	MKN							
8	U06.UN08.02.18 M	AS0V	X800	G742	5,85	1,72	4,4	17,7	0,4	6	UD09.0 UD12.0 UD13.0
10	U06.UN10.02.18 M	AS0U	X800	G742	5,85	1,38	4,8	17,7	0,32	6	UD09.0 UD12.0 UD13.0
11	U06.UN11.02.18 M	AS0T	X800	G742	5,85	1,25	4,8	17,7	0,29	6	UD09.0 UD12.0 UD13.0
12	U06.UN12.02.18 M	AS0S	X800	G742	5,85	1,15	4,8	17,7	0,27	6	UD09.0 UD12.0 UD13.0
14	U06.UN14.02.18 M	AS0Q	X800	G742	5,85	0,98	5,0	17,7	0,23	6	UD09.0 UD12.0 UD13.0
16	U06.UN16.02.18 M	AS0P	X800	G742	5,85	0,86	5,0	17,7	0,2	6	UD09.0 UD12.0 UD13.0
18	U06.UN18.02.18 M	AS0N	X800	G742	5,85	0,76	5,0	17,7	0,18	6	UD09.0 UD12.0 UD13.0
20	U06.UN20.02.18 M	AS0M	X800	G742	5,85	0,69	5,2	17,7	0,16	6	UD09.0 UD12.0 UD13.0
24	U06.UN24.02.18 M	AS0K	X800	G742	5,85	0,57	5,2	17,7	0,13	6	UD09.0 UD12.0 UD13.0

Bestellbeispiel // Order example: **U06.UN20.02.18 M X800** (X800 = Schneidstoff // Grade)

simmill AX
 simmill PMX
 simmill PX
 simmill SX
 simmill UX
 simmill VX
 simmill H2
 simmill K2
 simmill MX
 simmill OS
 Index

UN-Gewindefräsen, Vollprofil

Fräsen von UN-Gewinden, Vollprofil.

Thread milling, UN Full Profile

Thread milling of UN-threads, full profile.

Schnittwerte (Start) // Cutting parameters (start)

fzm	hmax	Vc
0,03 mm	0,04 mm	Seite/Page 638

Passende Klemmhalter auf Seite // Suitable toolholders on page
529, 530, 531, 532, 533

Bitte Hinweise im Anhang beachten // Please read add. notes

ALL (Seite/Page 645), H03 (Seite/Page 647), H07 (Seite/Page 648)



SP Legende
HM Legend

650



Scan QR-Code

Oder besuchen Sie // Or Visit
www.simtek.info/cp/880

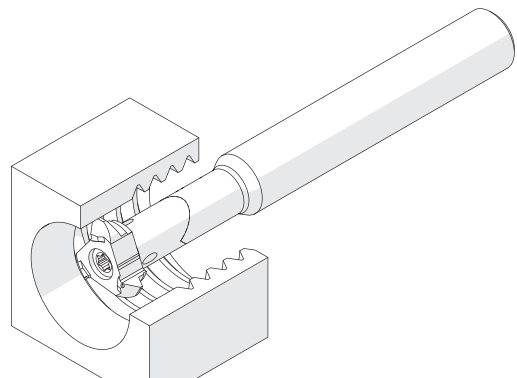
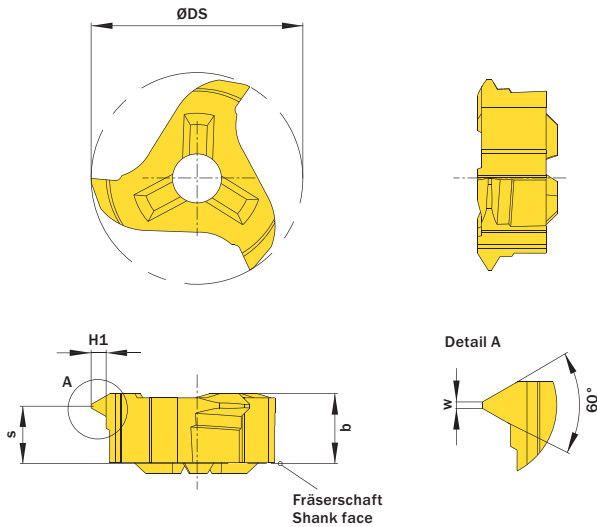


Illustration zeigt beispielhafte Anwendungsmöglichkeit mit ähnlichem Werkzeug.
 Image shows exemplary application possibility with similar tool.

Abbildung zeigt / Drawing shows: U18.UN11.02 M

Gang/Zoll Threads/Inch	Artikelnummer Part number	Webcode www.simtek.com/webcode	Unsere erste Wahl Our first choice		b	H1	S	ØDS	w	ZEFP	Connectcode www.simtek.com/code
			P M K N S	S							
6	U18.UN06.02 M	AS7Q	X800	GT42	5,85	2,291	4,2	17,7	0,53	3	UD09.0 UD12.0 UD13.0
7	U18.UN07.02 M	A4YF	X800	GT42	5,85	1,96	4,2	17,7	0,45	3	UD09.0 UD12.0 UD13.0 new
8	U18.UN08.02 M	AS04	X800	GT42	5,85	1,718	4,4	17,7	0,4	3	UD09.0 UD12.0 UD13.0
10	U18.UN10.02 M	AS03	X800	GT42	5,85	1,375	4,6	17,7	0,32	3	UD09.0 UD12.0 UD13.0
11	U18.UN11.02 M	AS02	X800	GT42	5,85	1,249	4,8	17,7	0,29	3	UD09.0 UD12.0 UD13.0
12	U18.UN12.02 M	AS01	X800	GT42	5,85	1,146	4,8	17,7	0,27	3	UD09.0 UD12.0 UD13.0
14	U18.UN14.02 M	AS00	X800	GT42	5,85	0,981	5,0	17,7	0,23	3	UD09.0 UD12.0 UD13.0
16	U18.UN16.02 M	AS0Z	X800	GT42	5,85	0,859	5,0	17,7	0,2	3	UD09.0 UD12.0 UD13.0
18	U18.UN18.02 M	AS0Y	X800	GT42	5,85	0,763	5,1	17,7	0,18	3	UD09.0 UD12.0 UD13.0
20	U18.UN20.02 M	AS0X	X800	GT42	5,85	0,687	5,2	17,7	0,16	3	UD09.0 UD12.0 UD13.0
24	U18.UN24.02 M	AS0W	X800	GT42	5,85	0,572	5,2	17,7	0,13	3	UD09.0 UD12.0 UD13.0

Bestellbeispiel // Order example: **U18.UN08.02 M X800** (X800 = Schneidstoff // Grade)

Whitworth-Rohrgewinde, Vollprofil

Fräsen von Whitworth-Gewinden, Vollprofil.

Whitworth Pipe Thread Milling, full profile

Whitworth pipe thread milling, full profile.

Schnittwerte (Start) // Cutting parameters (start)		
f _{zm} 0,03 mm	h _{max} 0,04 mm	V _c Seite/Page 638
Passende Klemmhalter auf Seite // Suitable toolholders on page 529, 530, 531, 532, 533		
Vergleichbare Werkzeuge auf Seite // Similar tools on page 468		
Bitte Hinweise im Anhang beachten // Please read add. notes ALL (Seite/Page 645), H03 (Seite/Page 647), H07 (Seite/Page 648)		

SP

HM

Legende
Legend

650

Scan
QR-Code

Oder besuchen Sie // Or Visit
www.simtek.info/cp/878

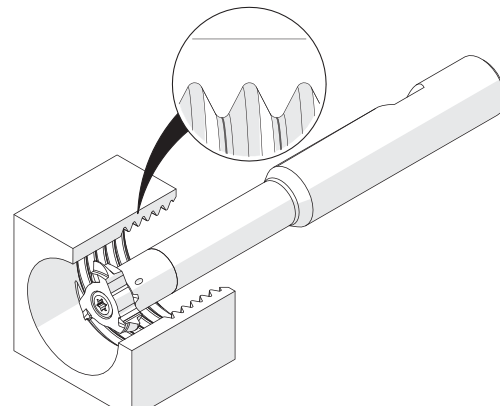
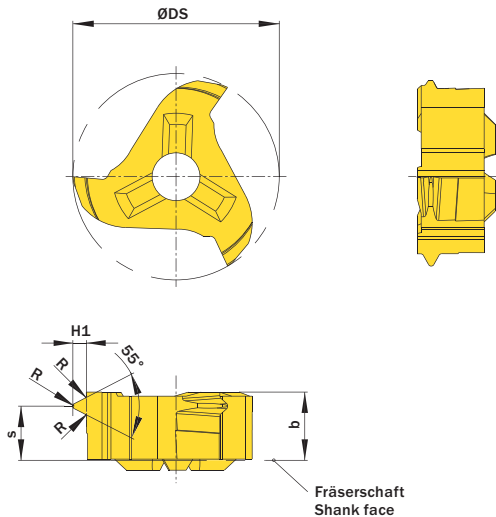


Illustration zeigt beispielhafte Anwendungsmöglichkeit mit ähnlichem Werkzeug.
 Image shows exemplary application possibility with similar tool.

Abbildung zeigt / Drawing shows: U18.BS14.02 M

Gang/Zoll Threads/Inch	Artikelnummer Part number	Webcode www.simtek.com/webcode	Unsere erste Wahl Our first choice		b	R	S	H1	ØDS	Ab Gewindegröße As of thread size	Alternativ ab Nenn Durchmesser Alternativ as of nominal diameter	ZEFP	Connectcode www.simtek.com/ccode
			P	MKN S									
11	U18.BS11.02 M	AS07	X800	GT42	5,85	0,32	4,4	1,48	17,7	G 1"	25,6	3	UD09.0 UD12.0 UD13.0
14	U18.BS14.02 M	AS06	X800	GT42	5,85	0,25	4,6	1,16	17,7	G 3/4"	24,0	3	UD09.0 UD12.0 UD13.0
19	U18.BS19.02 M	AS05	X800	GT42	5,85	0,18	4,9	0,86	17,7	-	22,8	3	UD09.0 UD12.0 UD13.0

Bestellbeispiel // Order example: **U18.BS11.02 M X800** (X800 = Schneidstoff // Grade)

simmill AX
simmill PMX
simmill PX
simmill SX
simmill UX
simmill VX
simmill H2
simmill K2
simmill MX
simmill OS
Index

Fräsen von Fasen

Fasenfräsen beidseitig.
 Geeignet ab Bohrungsdurchmesser 15,0 mm.

Chamfering

Chamfering on both sides.
 For use in bores as of minimum bore diameter 15,0 mm.

Schnittwerte (Start) // Cutting parameters (start)

f _{zm} 0,03 mm	h _{max} 0,04 mm	V _c Seite/Page 638
-----------------------------------	------------------------------------	---

Passende Klemmhalter auf Seite // Suitable toolholders on page
529, 530, 531, 532, 533

Vergleichbare Werkzeuge auf Seite // Similar tools on page
469

Bitte Hinweise im Anhang beachten // Please read add. notes

ALL (Seite/Page 645), H02 (Seite/Page 646), H07 (Seite/Page 648)



SP Legende
HM Legend
650

Scan QR-Code Oder besuchen Sie // Or Visit
www.simtek.info/cp/407

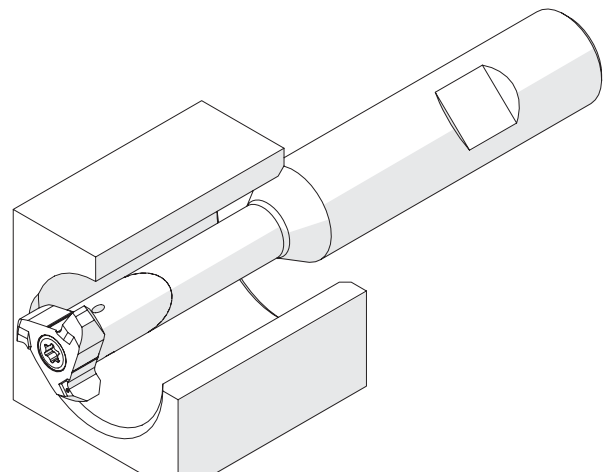
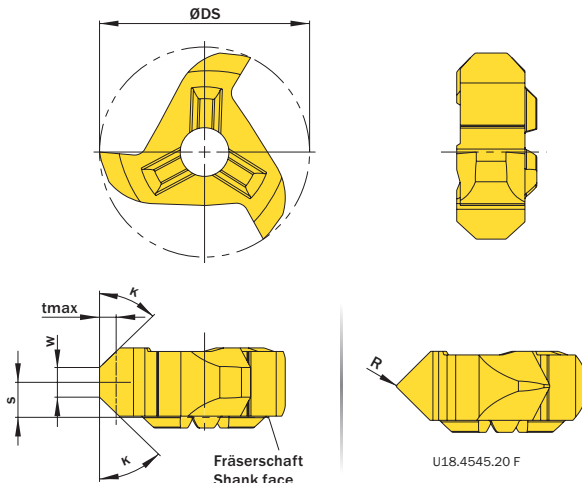


Illustration zeigt beispielhafte Anwendungsmöglichkeit mit ähnlichem Werkzeug.
 Image shows exemplary application possibility with similar tool.

Abbildung zeigt / Drawing shows: U18.4545.58 F

K	ØDmin (Min. Bohrung) ØDmin (min. bore)	Artikelnummer Partnumber	Webcode www.simtek.com/webcode	Unsere erste Wahl Our first choice		tmax	S	ØDS	w	ZEFP	Connectcode www.simtek.com/ccode
	mm			P	M						
45°	15,0	U15.4545.58 F	AGQF	X800	GT42	2,5	3,0	14,7	0,2	3	UD09.0
45°	18,0	U18.4545.20 F	AHA2	X800	GT42	2,5	3,0	17,7	0,2	3	UD09.0 UD12.0 UD13.0
45°	18,0	U18.4545.58 F	ACKW	X800	GT42	1,4	3,0	17,7	2,5	3	UD09.0 UD12.0 UD13.0

Bestellbeispiel // Order example: **U18.4545.58 F X800** (X800 = Schneidstoff // Grade)

Fräsen von Fasen

Fasenfräsen beidseitig.
 Geeignet ab Bohrungsdurchmesser 15,0 mm.

Chamfering

Chamfering on both sides.
 For use in bores as of minimum bore diameter 15,0 mm.

Schnittwerte (Start) // Cutting parameters (start)		
fzm 0,03 mm	hmax 0,04 mm	Vc Seite/Page 638
Passende Klemmhalter auf Seite // Suitable toolholders on page 529, 530, 531, 532, 533		
Vergleichbare Werkzeuge auf Seite // Similar tools on page 469		
Bitte Hinweise im Anhang beachten // Please read add. notes ALL (Seite/Page 645), H05 (Seite/Page 648), H07 (Seite/Page 648)		

SP

Legende

HM

Legend

650

Scan QR-Code

Oder besuchen Sie // Or Visit
www.simtek.info/cp/409

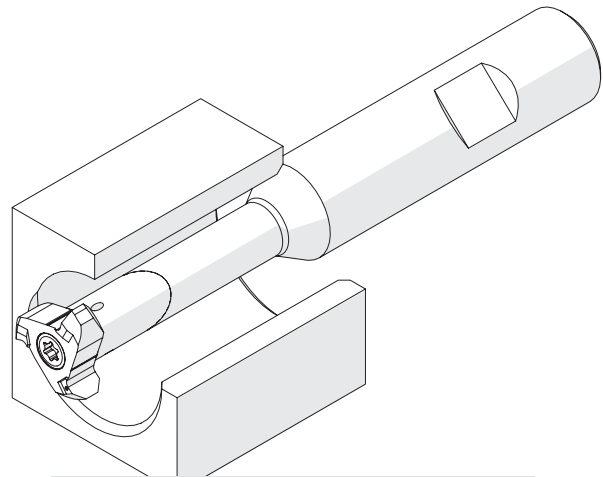
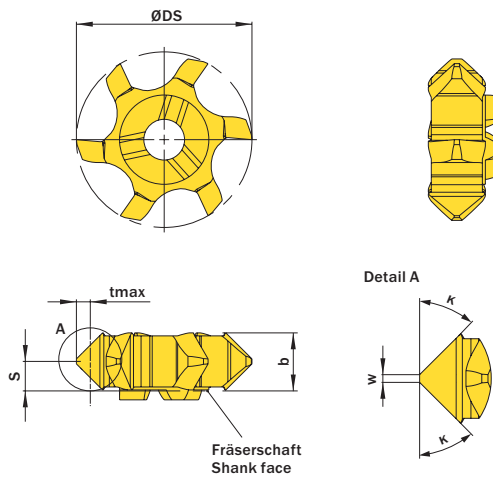


Illustration zeigt beispielhafte Anwendungsmöglichkeit mit ähnlichem Werkzeug.
 Image shows exemplary application possibility with similar tool.

Abbildung zeigt / Drawing shows: U06.4545.020.18 F

K	W mm	ØDmin (Min. Bohrung) ØDmin (min. bore) mm	Artikelnummer Part number	Webcode www.simtek.com/webcode	Unsere erste Wahl Our first choice		S mm	b mm	tmax mm	ØDS mm	ZEFP	Connectcode www.simtek.com/ccode
					P	M						
▼ ØDmin (Min. Bohrung) // ØDmin (min. bore) = 15,0 mm												
45°	0,5	15,0	U06.4545.050.15 F	AQWM	X800	GT42	3,0	5,75	1,6	14,7	6	UD09.0
▼ ØDmin (Min. Bohrung) // ØDmin (min. bore) = 18,0 mm												
30°	0,2	18,0	U06.3030.020.18 F	AZT8	X800	GT42	3,0	5,85	1,5	17,7	6	UD09.0 UD12.0 UD13.0
45°	0,2	18,0	U06.4545.020.18 F	AK5Y	X800	GT42	3,0	5,75	2,2	17,7	6	UD09.0 UD12.0 UD13.0

Bestellbeispiel // Order example: **U06.4545.020.18 F X800** (X800 = Schneidstoff // Grade)

Stirn- und Planfräsen

Schneidkreisdurchmesser ab 17,7 mm mit 6 Schneiden.

Face Milling

Tool diameter of 17,7 mm with 6 cutting edges.

Schnittwerte (Start) // Cutting parameters (start)		
fzm 0,03 mm	hmax 0,04 mm	Vc Seite/Page 638

Passende Klemmhalter auf Seite // Suitable toolholders on page
529, 530, 531, 532, 533

Vergleichbare Werkzeuge auf Seite // Similar tools on page
471

Bitte Hinweise im Anhang beachten // Please read add. notes
H07 (Seite/Page 648)

SP

Legende

HM

Legende

Scan QR-Code

650

Oder besuchen Sie // Or Visit
www.simtek.info/cp/1214

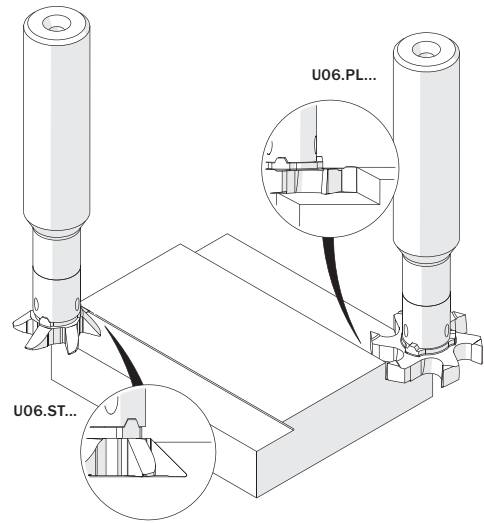
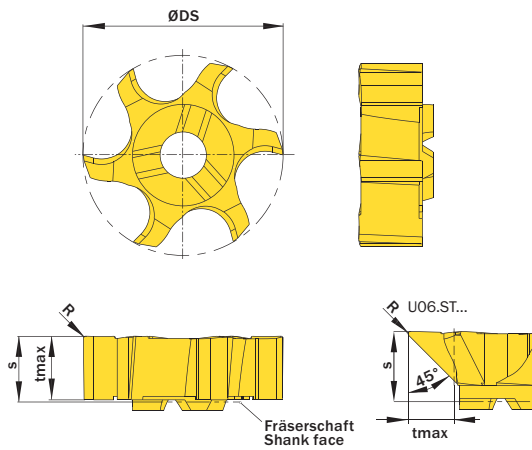


Abbildung zeigt / Drawing shows: U06.PL55.020.18 Y

tmax	R	ØDmin (Min. Bohrung) ØDmin (min. bore)	Artikelnummer Part number	Webcode www.simtek.com/webcode	Unsere erste Wahl Our first choice	S	ØDS	ZEFF // ZEFF	Connectcode www.simtek.com/ccode
mm	mm	mm			P M K N S	mm	mm		
5,5	0,2	18,0	U06.PL55.020.18 Y	AZUD	X800 GT42	5,8	17,7	6	UD09.0 UD12.0 UD13.0
4,0	0,2	18,0	U06.ST40.020.18 Y	A03G	X800 GT42	5,8	17,7	6	UD09.0

Bestellbeispiel // Order example: **U06.PL55.020.18 Y X800** (X800 = Schneidstoff // Grade)



Ab Seite // As of page

461

Anwendungsübersicht
Application overview

simmill AX

simmill PMX

simmill PX

simmill SX

simmill UX

simmill VX

simmill H2

simmill K2

simmill MX

simmill OS

Index

555

Fräserschaft, zylindrisch (vgl. DIN 6535 HA)

Schwingungsgedämpfte Hartmetall-Ausführung mit innerer Kühlmittelzufuhr und Aufnahme nach DIN 6535 HA.

Milling cutter shank, cylindrical (DIN 6535 HA)

Anti-vibration solid carbide type with through coolant and shank according to DIN 6535 HA.

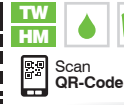
Anzugsmoment (Schraube) // Tightening torque (screw)

7,0 Nm

Vergleichbare Werkzeuge auf Seite // Similar tools on page
473

Bitte Hinweise im Anhang beachten // Please read add. notes

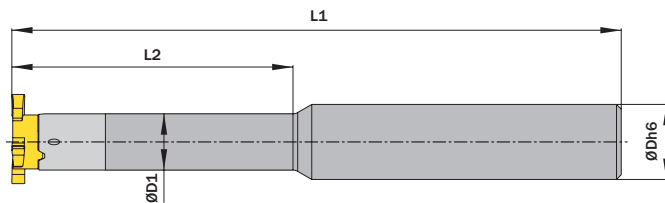
ALL (Seite/Page 645)



Legende
Legend **650**

Scan
QR-Code

Oder besuchen Sie // Or Visit
www.simtek.info/cp/274



ØDh6	ØD1	L2	Artikelnummer Part number	Webcode www.simtek.com/webcode	L1	Schraube Screw	Schraubenschlüssel Screw driver	Connectcode www.simtek.com/code
mm	mm	mm			mm			
▼ ØDh6 = 12,0 mm								
12,0	12,0	42,0	V22.1212.42 A HM	ABVM	100,0	VM5x12 T20T	T20T	VD12.0
12,0	12,0	60,0	V22.1212.60 A HM	AP4C	130,0	VM5x12 T20T	T20T	VD12.0
▼ ØDh6 = 16,0 mm								
16,0	11,5	30,0	V22.1611.30 A HM	AMKQ	90,0	VM5x12 T20T	T20T	VD11.5
16,0	12,0	42,0	V22.1612.42 A HM	AAJW	100,0	VM5x12 T20T	T20T	VD12.0
16,0	12,0	60,0	V22.1612.60 A HM	AEYP	130,0	VM5x12 T20T	T20T	VD12.0
16,0	12,0	85,0	V22.1612.85 A HM	AJS8	160,0	VM5x12 T20T	T20T	VD12.0
16,0	14,3	42,0	V28.1614.42 A HM	AGNA	100,0	VM5x12 T20T	T20T	VD14.3
16,0	14,3	60,0	V28.1614.60 A HM	AFWJ	130,0	VM5x12 T20T	T20T	VD14.3
16,0	14,3	85,0	V28.1614.85 A HM	ANDA	160,0	VM5x12 T20T	T20T	VD14.3
16,0	9,0	33,0	V33.1609.33 A HM	AAWZ	100,0	VM5x12 T20T	T20T	VD09.0
▼ ØDh6 = 20,0 mm								
20,0	16,0	45,0	V22.2016.45 A HM	AF6W	110,0	VM5x12 T20T	T20T	VD16.0
20,0	16,0	65,0	V22.2016.65 A HM	ACHN	130,0	VM5x12 T20T	T20T	VD16.0
20,0	13,5	35,0	V28.2013.35 A HM	AE3N	104,0	VM5x12 T20T	T20T	VD13.5
20,0	14,3	85,0	V28.2014.85 A HM	AFNT	160,0	VM5x12 T20T	T20T	VD14.3

Bestellbeispiel // Order example: **V22.1612.42 A HM**

Fräserschaft, zylindrisch (vgl. DIN 6535 HA)

Schwingungsgedämpfte Hartmetall-Ausführung mit innerer Kühlmittelzufuhr und Aufnahme nach DIN 6535 HA.

Milling Cutter Shank, cylindrical (DIN 6535 HA)

Anti-vibration solid carbide type with through coolant and shank according to DIN 6535 HA.

Anzugsmoment (Schraube) // Tightening torque (screw)

7,0 Nm

Vergleichbare Werkzeuge auf Seite // Similar tools on page

473

Bitte Hinweise im Anhang beachten // Please read add. notes

ALL (Seite/Page 645)

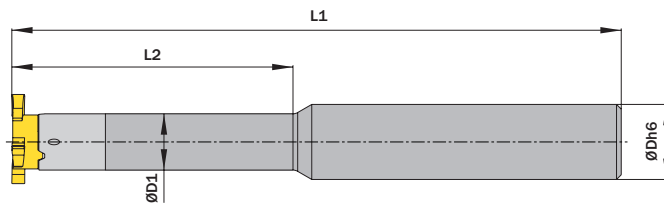


Legende Legend **650**



Scan QR-Code

Oder besuchen Sie // Or Visit www.simtek.info/cp/428



ØDh6	ØD1	L2	Artikelnummer Part number	Webcode www.simtek.com/webcode	L1	Schraube Screw	Schraubenschlüssel Screw driver	Connectcode www.simtek.com/code	
mm	mm	mm			mm				
▼ ØDh6 = 12,7 mm									
12,7	12,7	42,0	V22.0.500.13.42 A HM	AHBS	100,0	VM5x12 T20T	T20T	VD12.7	<small>Inch</small>
12,7	12,7	60,0	V22.0.500.13.60 A HM	AGT2	130,0	VM5x12 T20T	T20T	VD12.7	<small>Inch</small>
▼ ØDh6 = 15,875 mm									
15,875	11,5	30,0	V22.0.625.11.30 A HM	AJ9X	90,0	VM5x12 T20T	T20T	VD11.5	<small>Inch</small>
15,875	12,0	42,0	V22.0.625.12.42 A HM	APKM	100,0	VM5x12 T20T	T20T	VD12.0	<small>Inch</small>
15,875	12,0	60,0	V22.0.625.12.60 A HM	AMEX	130,0	VM5x12 T20T	T20T	VD12.0	<small>Inch</small>
15,875	12,0	85,0	V22.0.625.12.85 A HM	AAG1	160,0	VM5x12 T20T	T20T	VD12.0	<small>Inch</small>
15,875	14,3	42,0	V28.0.625.14.42 A HM	AD3T	100,0	VM5x12 T20T	T20T	VD14.3	<small>Inch</small>
15,875	14,3	60,0	V28.0.625.14.60 A HM	AK1F	130,0	VM5x12 T20T	T20T	VD14.3	<small>Inch</small>
15,875	14,3	85,0	V28.0.625.14.85 A HM	AD9S	160,0	VM5x12 T20T	T20T	VD14.3	<small>Inch</small>

Bestellbeispiel // Order example: **V28.0.625.14.42 A HM**

simmill AX

simmill PMX

simmill PX

simmill SX

simmill UX

simmill VX

simmill H2

simmill K2

simmill MX

simmill OS

Index

Fräserschaft, zylindrisch (vgl. DIN 1835 A)

Stahl-Ausführung mit Aufnahme nach DIN 1835 A.

Milling cutter shank, cylindrical (DIN 1835 A)

Steel type with shank according to DIN 1835 A.

Anzugsmoment (Schraube) // Tightening torque (screw)

7,0 Nm

Vergleichbare Werkzeuge auf Seite // Similar tools on page
474

Bitte Hinweise im Anhang beachten // Please read add. notes

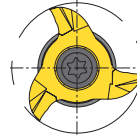
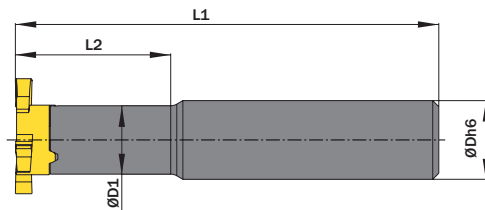
ALL (Seite/Page 645)



Legende
Legend **650**



Oder besuchen Sie // Or Visit
www.simtek.info/cp/275



ØDh6	ØD1	L2	Artikelnummer Part number	Webcode www.simtek.com/webcode	Mit Kühlmittelzufuhr With through coolant supply	L1	Schraube Screw	Schraubenschlüssel Screw driver	Connectcode www.simtek.com/code
mm	mm	mm				mm			
▼ ØDh6 = 10,0 mm									
10,0	11,3	10,7	V22.1011.10 A ST	ABCX	Nein / No	60,0	V M5x12 T20T	T20T	VD11.3
▼ ØDh6 = 13,0 mm									
13,0	11,3	25,7	V22.1311.25 A ST	ACUJ	Nein / No	70,0	V M5x12 T20T	T20T	VD11.3
13,0	14,0	10,7	V28.1314.10 A ST	AB44	Nein / No	70,0	V M5x12 T20T	T20T	VD14.0
▼ ØDh6 = 15,875 mm									
15,875	12,0	24,0	V22.0.625.12.24 A ST	AN3S	Ja / Yes	80,0	V M5x12 T20T	T20T	VD12.0 new
▼ ØDh6 = 16,0 mm									
16,0	12,0	24,0	V22.1612.24 A ST	AHCØ	Ja / Yes	80,0	V M5x12 T20T	T20T	VD12.0
▼ ØDh6 = 19,05 mm									
19,05	14,0	35,7	V28.0.750.14.35 A ST	A4NV	Ja / Yes	100,0	V M5x12 T20T	T20T	VD14.0 new
▼ ØDh6 = 20,0 mm									
20,0	14,0	35,7	V28.2014.35 A ST	AEWT	Ja / Yes	100,0	V M5x12 T20T	T20T	VD14.0

Bestellbeispiel // Order example: **V22.1612.24 A ST**

Fräserschaft, Weldon (vgl. DIN 6535 HB)

Schwingungsgedämpfte Hartmetall-Ausführung mit innerer Kühlmittelzufuhr und Aufnahme nach DIN 6535 HB.

Milling cutter shank, Weldon (DIN 6535 HB)

Anti-vibration solid carbide type with through coolant and shank according to DIN 6535 HB.

Anzugsmoment (Schraube) // Tightening torque (screw)

7,0 Nm

Vergleichbare Werkzeuge auf Seite // Similar tools on page
475

Bitte Hinweise im Anhang beachten // Please read add. notes

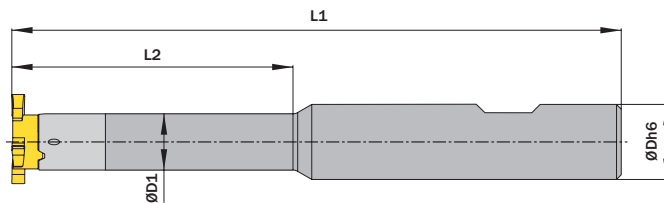
ALL (Seite/Page 645)



Legende
Legend **650**

Scan QR-Code

Oder besuchen Sie // Or Visit
www.simtek.info/cp/276



ØDh6	ØD1	L2	Artikelnummer Part number	Webcode www.simtek.com/webcode	L1	Schraube Screw	Schraubenschlüssel Screw driver	Connectcode www.simtek.com/code
mm	mm	mm			mm			
▼ ØDh6 = 12,0 mm								
12,0	12,0	42,0	V22.1212.42 B HM	APJA	100,0	VM5x12 T20T	T20T	VD12.0
12,0	12,0	60,0	V22.1212.60 B HM	AJ81	130,0	VM5x12 T20T	T20T	VD12.0
▼ ØDh6 = 16,0 mm								
16,0	11,5	30,0	V22.1611.30 B HM	AKP6	90,0	VM5x12 T20T	T20T	VD11.5
16,0	12,0	42,0	V22.1612.42 B HM	AHES	100,0	VM5x12 T20T	T20T	VD12.0
16,0	12,0	60,0	V22.1612.60 B HM	AD03	130,0	VM5x12 T20T	T20T	VD12.0
16,0	12,0	85,0	V22.1612.85 B HM	APYY	160,0	VM5x12 T20T	T20T	VD12.0
16,0	14,3	42,0	V28.1614.42 B HM	ANNZ	100,0	VM5x12 T20T	T20T	VD14.3
16,0	14,3	60,0	V28.1614.60 B HM	AJ23	130,0	VM5x12 T20T	T20T	VD14.3
16,0	14,3	85,0	V28.1614.85 B HM	AGBC	160,0	VM5x12 T20T	T20T	VD14.3
16,0	9,0	33,0	V33.1609.33 B HM	APSS	100,0	VM5x12 T20T	T20T	VD09.0
▼ ØDh6 = 20,0 mm								
20,0	16,0	45,0	V22.2016.45 B HM	AG2G	110,0	VM5x12 T20T	T20T	VD16.0
20,0	16,0	65,0	V22.2016.65 B HM	AHNF	130,0	VM5x12 T20T	T20T	VD16.0
20,0	13,5	35,0	V28.2013.35 B HM	ACWV	104,0	VM5x12 T20T	T20T	VD13.5
20,0	14,3	85,0	V28.2014.85 B HM	AF3D	160,0	VM5x12 T20T	T20T	VD14.3

Bestellbeispiel // Order example: **V22.1612.42 B HM**

simmill AX

simmill PMX

simmill PX

simmill SX

simmill UX

simmill VX

simmill H2

simmill K2

simmill MX

simmill OS

Index

Fräserschaft, Weldon (vgl. DIN 6535 HB)

Schwingungsgedämpfte Hartmetall-Ausführung mit innerer Kühlmittelzufuhr und Aufnahme nach DIN 6535 HB.

Milling Cutter Shank, Weldon (DIN 6535 HB)

Anti-vibration solid carbide type with through coolant and shank according to DIN 6535 HB.

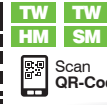
Anzugsmoment (Schraube) // Tightening torque (screw)

7,0 Nm

Vergleichbare Werkzeuge auf Seite // Similar tools on page
475

Bitte Hinweise im Anhang beachten // Please read add. notes

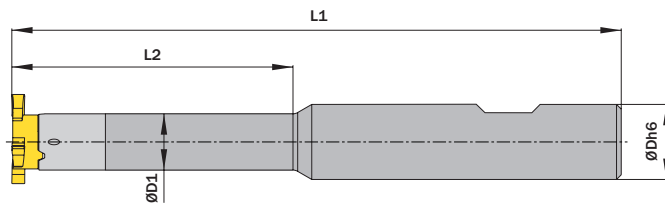
ALL (Seite/Page 645)



Legende
Legend **650**

Scan
QR-Code

Oder besuchen Sie // Or Visit
www.simtek.info/cp/429



ØDh6	ØD1	L2	Artikelnummer Part number	Webcode www.simtek.com/webcode	L1	Schraube Screw	Schraubenschlüssel Screw driver	Connectcode www.simtek.com/code	
▼ ØDh6 = 12,7 mm									
12,7	12,7	42,0	V22.0.500.13.42 B HM	AH67	100,0	VM5x12 T20T	T20T	VD12.7	Inch
12,7	12,7	60,0	V22.0.500.13.60 B HM	AKZA	130,0	VM5x12 T20T	T20T	VD12.7	Inch
▼ ØDh6 = 15,875 mm									
15,875	11,5	30,0	V22.0.625.11.30 B HM	AG3Z	90,0	VM5x12 T20T	T20T	VD11.5	Inch
15,875	12,0	42,0	V22.0.625.12.42 B HM	AC12	100,0	VM5x12 T20T	T20T	VD12.0	Inch
15,875	12,0	60,0	V22.0.625.12.60 B HM	ACUX	130,0	VM5x12 T20T	T20T	VD12.0	Inch
15,875	12,0	85,0	V22.0.625.12.85 B HM	ABYS	160,0	VM5x12 T20T	T20T	VD12.0	Inch
15,875	14,3	42,0	V28.0.625.14.42 B HM	AFE3	100,0	VM5x12 T20T	T20T	VD14.3	Inch
15,875	14,3	60,0	V28.0.625.14.60 B HM	AB65	130,0	VM5x12 T20T	T20T	VD14.3	Inch
15,875	14,3	85,0	V28.0.625.14.85 B HM	AKGV	160,0	VM5x12 T20T	T20T	VD14.3	Inch
15,875	9,0	33,0	V33.0.625.09.33 B HM	A28K	100,0	VM5x12 T20T	T20T	VD09.0	new Inch

Bestellbeispiel // Order example: **V22.0.500.13.42 B HM**

Fräserschaft, Weldon (vgl. DIN 1835 B)

Stahl-Ausführung mit innerer
Kühlmittelzufuhr und Aufnahme nach DIN 1835 B.

Milling Cutter Shank, Weldon (DIN 1835 B)

Steel type with through coolant and shank according to DIN 1835 B.

Anzugsmoment (Schraube) // Tightening torque (screw)

7,0 Nm

Vergleichbare Werkzeuge auf Seite // Similar tools on page
476

Bitte Hinweise im Anhang beachten // Please read add. notes

ALL (Seite/Page 645)



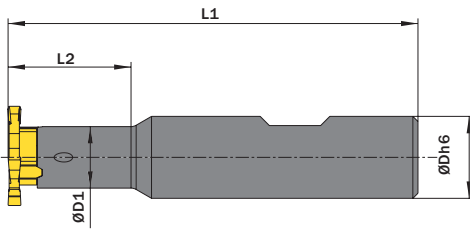
Legende
Legend **650**



Scan
QR-Code

Oder besuchen Sie // Or Visit
www.simtek.info/cp/423

Whistle-Notch Aufnahme auf Anfrage erhältlich.
Whistle-Notch fixation available upon request.



ØDh6	ØD1	L2	Artikelnummer Part number	Webcode www.simtek.com/webcode	L1	Schraube Screw	Schraubenschlüssel Screw driver	Connectcode www.simtek.com/code	
mm	mm	mm			mm				
▼ ØDh6 = 15,875 mm									
15,875	12,0	24,0	V22.0.625.12.24 B ST	AD8N	80,0	VM5x12 T20T	T20T	VD12.0	<small>frisch new inch</small>
15,875	9,0	20,0	V33.0.625.09.20 B ST	A28J	80,0	VM5x12 T20T	T20T	VD09.0	
▼ ØDh6 = 16,0 mm									
16,0	12,0	24,0	V22.1612.24 B ST	AFWU	80,0	VM5x12 T20T	T20T	VD12.0	
16,0	9,0	20,0	V33.1609.20 B ST	AB46	80,0	VM5x12 T20T	T20T	VD09.0	
▼ ØDh6 = 20,0 mm									
20,0	14,0	35,7	V28.2014.35 B ST	AE05	100,0	VM5x12 T20T	T20T	VD14.0	

Bestellbeispiel // Order example: **V22.1612.24 B ST**

Fräserschaft, zylindrisch (vgl. DIN 1835 A)

Stahl-Ausführung mit Aufnahme nach DIN 1835 A.
 Für hohe Stabilität bei Planfräsoptionen.

Milling cutter shank, cylindrical (DIN 1835 A)

Steel type with shank according to DIN 1835 A.
 High stability in face milling operations.

Anzugsmoment (Schraube) // Tightening torque (screw)

7,0 Nm

Vergleichbare Werkzeuge auf Seite // Similar tools on page
476

Bitte Hinweise im Anhang beachten // Please read add. notes

ALL (Seite/Page 645)



Legende
 Legend **650**



Scan
 QR-Code

Oder besuchen Sie // Or Visit
www.simtek.info/cp/1341

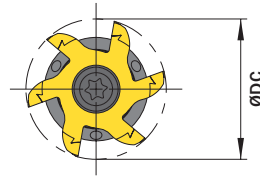
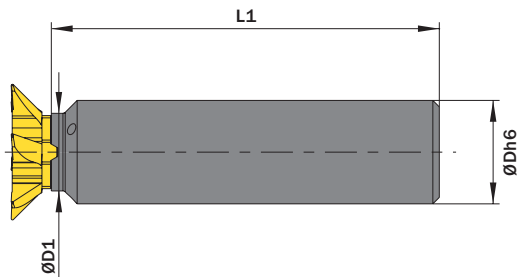


Abbildung zeigt / Drawing shows: V22.1612.00.06 A ST

ØDh6	ØD1	Artikelnummer Part number	Webcode www.simtek.com/webcode	L1	Schraube Screw	Schraubenschlüssel Screw driver	Connectcode www.simtek.com/code	
mm	mm			mm				
16,0	12,0	V22.1612.00.06 A ST	A6F1	60,0	VM5x12 T20T	T20T	VD12.0	new
16,0	12,0	V22.1612.00.10 A ST	A6G1	120,0	VM5x12 T20T	T20T	VD12.0	new

Bestellbeispiel // Order example: **V22.1612.00.10 A ST**

simmill AX

simmill PMX

simmill PX

simmill SX

simmill UX

simmill VX

simmill H2

simmill K2

simmill MX

simmill OS

Index

Fräserschaft, für Spannzangenfutter (DIN 6499)

Für Spannzangenfutter nach DIN6499-A.

Milling cutter shank, for collet chucks (DIN6499)

For collet chucks according to DIN6499-A.

Anzugsmoment (Schraube) // Tightening torque (screw)

7,0 Nm

Vergleichbare Werkzeuge auf Seite // Similar tools on page
472

Bitte Hinweise im Anhang beachten // Please read add. notes
ALL (Seite/Page 645)



TW
ST

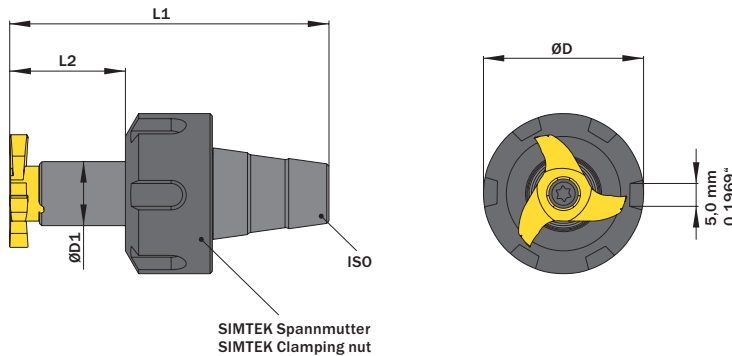
Legende
Legend

650



Scan
QR-Code

Oder besuchen Sie // Or Visit
www.simtek.info/cp/456



Fräserschaft ist nur mit passender Spannmutter verfügbar.
Spannmutter ist auch einzeln als Ersatzteil verfügbar.
Milling cutter shank is only available together with clamping nut.
Clamping nut is available as a spare part.

Für Spannzange For collet chuck	ØD1 mm	L2 mm	Artikelnummer Part number	Webcode www.simtek.com/webcode	Spannmutter Clamping nut	Gewinde Spannmutter Thread clamping nut	ØD mm	L1 mm	Schraube Screw	Schraubenschlüssel Screw driver	Connectcode www.simtek.com/code
▼ Für Spannzange // For collet chuck = ER16											
ER16	12,0	30,0	V22.ER16.12.30	AD5W	VER16.18.32	M22x1,5	32,0	60,0	VM5x12 T20T	T20T	VD12.0
ER16	12,0	30,0	V22.ER16.12.30.B	AVMX	VER16.18.22	M19x1,0	22,0	60,0	VM5x12 T20T	T20T	VD12.0
ER16	12,0	30,0	V22.ER16.12.30.C	AVMY	VER16.18.25	M19x1,0	25,0	60,0	VM5x12 T20T	T20T	VD12.0
▼ Für Spannzange // For collet chuck = ER20											
ER20	12,0	30,0	V22.ER20.12.30	APJ7	VER20.19.35	M25x1,5	35,0	65,65	VM5x12 T20T	T20T	VD12.0
ER20	12,0	30,0	V22.ER20.12.30.B	AVM1	VER20.19.28	M24x1,0	28,0	65,65	VM5x12 T20T	T20T	VD12.0
ER20	14,0	35,0	V28.ER20.14.35	ABJC	VER20.19.35	M25x1,5	35,0	69,5	VM5x12 T20T	T20T	VD14.0
ER20	14,0	35,0	V28.ER20.14.35.B	AVM2	VER20.19.28	M24x1,0	28,0	69,5	VM5x12 T20T	T20T	VD14.0
▼ Für Spannzange // For collet chuck = ER25											
ER25	12,0	30,0	V22.ER25.12.30	AESQ	VER25.20.42	M32x1,5	42,0	68,0	VM5x12 T20T	T20T	VD12.0
ER25	12,0	30,0	V22.ER25.12.30.B	AVM4	VER25.20.35	M30x1,0	35,0	68,0	VM5x12 T20T	T20T	VD12.0
ER25	14,0	19,0	V22.ER25.14.19	AMP6	VER25.20.42	M32x1,5	42,0	63,0	VM5x12 T20T	T20T	VD14.0
ER25	14,0	19,0	V22.ER25.14.19.B	AVM5	VER25.20.35	M30x1,0	35,0	63,0	VM5x12 T20T	T20T	VD14.0
ER25	14,0	35,0	V28.ER25.14.35	APAS	VER25.20.42	M32x1,5	42,0	73,0	VM5x12 T20T	T20T	VD14.0
ER25	14,0	35,0	V28.ER25.14.35.B	AVM6	VER25.20.35	M30x1,0	35,0	73,0	VM5x12 T20T	T20T	VD14.0
▼ Für Spannzange // For collet chuck = ER32											
ER32	12,0	30,0	V22.ER32.12.30	AFVA	VER32.23.50	M40x1,5	50,0	74,0	VM5x12 T20T	T20T	VD12.0
ER32	14,0	19,0	V22.ER32.14.19	AKXJ	VER32.23.50	M40x1,5	50,0	63,0	VM5x12 T20T	T20T	VD14.0
ER32	14,0	35,0	V28.ER32.14.35	AC0B	VER32.23.50	M40x1,5	50,0	79,0	VM5x12 T20T	T20T	VD14.0

Bestellbeispiel // Order example: **V28.ER25.14.35**

simmill AX

simmill PMX

simmill PX

simmill SX

simmill UX

simmill VX

simmill H2

simmill K2

simmill MX

simmill OS

Index

SIMTEK Fräserschaft

SIMTEK Trägerwerkzeug mit Polygonschaft nach ISO 26623.

SIMTEK Milling Cutter

SIMTEK toolholder with polygon shank according to ISO 26623.

Anzugsmoment (Schraube) // Tightening torque (screw)

7,0 Nm

Bitte Hinweise im Anhang beachten // Please read add. notes

ALL (Seite/Page 645)



TW
ST

Legende
Legend

650



Scan
QR-Code

Oder besuchen Sie // Or Visit
www.simtek.info/cp/950

SIMTEK Trägerwerkzeug mit
Polygonschaft nach ISO 26623
SIMTEK toolholder with polygon shank
according to ISO 26623

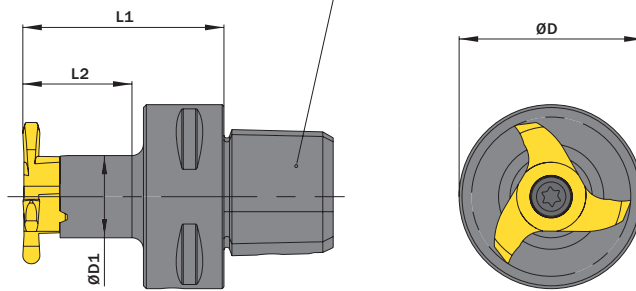


Abbildung zeigt / Drawing shows: V22.C312.18

Polygonschaftgröße Polygon shank size	ØD1	L2	Artikelnummer Part number	Webcode www.simtek.com/webcode	L1	ØD	ØDS	Schraube Screw	Schraubenschlüssel Screw driver	Connectcode www.simtek.com/code
	mm	mm								
C3	12,0	18,5	V22.C312.18	AUP4	35,0	32,0	21,7	V M5x12 T20T	T20T	VD12.0

Bestellbeispiel // Order example: **V22.C312.18**

Fräsen von Sicherungsringnuten, innen

Fräsen von Sicherungsringnuten in Bohrungen ab Bohrungsdurchmesser 22,0 mm. Geeignet für alle Materialien.

Circlip Ring Groove Milling, internal

Circlip ring groove milling in bores as of bore diameter 22,0 mm. For use in all materials.

Schnittwerte (Start) // Cutting parameters (start)		
fzm 0,04 mm	hmax 0,05 mm	Vc Seite/Page 638
Passende Klemmhalter auf Seite // Suitable toolholders on page 556, 557, 558, 559, 560, 561, 562, 563, 564		
Vergleichbare Werkzeuge auf Seite // Similar tools on page 463		
Bitte Hinweise im Anhang beachten // Please read add. notes ALL (Seite/Page 645), H01 (Seite/Page 646), H07 (Seite/Page 648)		

SP Legende

HM Legend

650

Scan QR-Code Oder besuchen Sie // Or Visit
www.simtek.info/cp/371

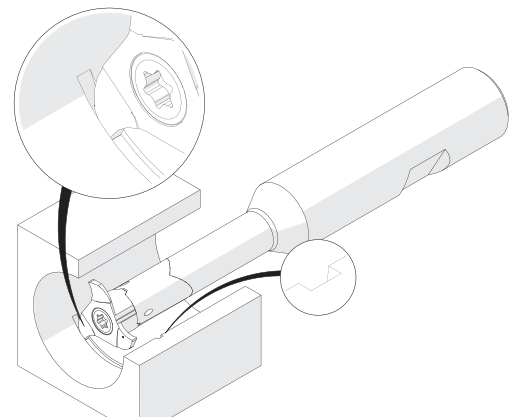
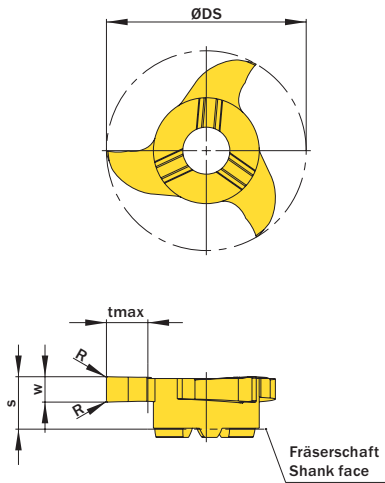


Illustration zeigt beispielhafte Anwendungsmöglichkeit mit ähnlichem Werkzeug.
Image shows exemplary application possibility with similar tool.

Abbildung zeigt / Drawing shows: V22.0265.02 G

w ^{-0,02}	Nuttenbreite Nominal width of groove	R	ØDmin (Min.-Bohrung) ØDmin (min. bore)	Artikelnummer Part number	Webcode www.simtek.com/webcode	Unsere erste Wahl Our first choice		tmax	S	ØDS	ZEFP	Connectcode www.simtek.com/ccode	upd
						P M K N S	S						
0,77	0,7	-	22,0	V22.0070.00 Z	ABDX	X808	HT42	1,5	5,6	21,7	3	VD12.0	upd
0,87	0,8	-	22,0	V22.0080.00 Z	AP3G	X808	HT42	1,7	5,6	21,7	3	VD12.0	upd
0,97	0,9	-	22,0	V22.0090.00 Z	AJMH	X808	HT42	1,9	5,6	21,7	3	VD12.0	upd
1,07	1,0	-	22,0	V22.0100.00 Z	AMB0	X808	HT42	2,1	5,6	21,7	3	VD12.0	upd
1,24	1,1	-	22,0	V22.0110.00 Z	APJY	X808	HT42	2,5	5,7	21,7	3	VD12.0	upd
1,44	1,3	0,1	22,0	V22.0130.01 G	ACS5	X800	GT42	4,5	5,7	21,7	3	VD12.0	upd
1,74	1,6	0,1	22,0	V22.0160.01 G	ABJ5	X800	GT42	4,5	5,7	21,7	3	VD12.0	upd
1,99	1,85	0,2	22,0	V22.0185.02 G	AGKU	X800	GT42	4,5	5,7	21,7	3	VD12.0	upd
2,29	2,15	0,2	22,0	V22.0215.02 G	AFGW	X800	GT42	4,5	5,7	21,7	3	VD12.0	upd
2,79	2,65	0,2	22,0	V22.0265.02 G	ADKF	X800	GT42	4,5	5,7	21,7	3	VD12.0	upd
3,29	3,15	0,2	22,0	V22.0315.02 G	AMP1	X800	GT42	4,5	5,7	21,7	3	VD12.0	upd
4,29	4,15	0,2	22,0	V22.0415.02 G	AE13	X800	GT42	4,5	5,7	21,7	3	VD12.0	upd
5,29	5,15	0,2	22,0	V22.0515.02 G	AEK1	X800	GT42	4,5	5,7	21,7	3	VD12.0	upd
5,29	5,15	0,4	22,0	V22.0515.04 G	AAG9	X800	GT42	4,5	5,7	21,7	3	VD12.0	upd

Bestellbeispiel // Order example: **V22.0515.04 G X800** (X800 = Schneidstoff // Grade)

simtek individual V22. w, 1/100 mm, 4 Stellen/Digits . R, 1/100 mm, 3 Stellen/Digits Toleranz // Tolerance
Beispielartikelnummer // Example Part number: **V22.0179.030 XG**

simmill AX
simmill PMX
simmill PX
simmill SX
simmill UX
simmill VX
simmill H2
simmill K2
simmill MX
simmill OS
Index

Fräsen von Sicherungsringnuten, innen

Fräsen von Sicherungsringnuten in Bohrungen ab Bohrungsdurchmesser 22,0 mm. Durch hochpositive Schneidengeometrie besonders geeignet für Leichtmetalle.

Circlip Ring Groove Milling, internal

Circlip ring groove milling in bores as of bore diameter 22,0 mm. High positive rake angle for use in light alloys.

Schnittwerte (Start) // Cutting parameters (start)

fzm 0,04 mm	hmax 0,05 mm	Vc Seite/Page 638
-----------------------	------------------------	-----------------------------

Passende Klemmhalter auf Seite // Suitable toolholders on page
556, 557, 558, 559, 560, 561, 562, 563, 564

Vergleichbare Werkzeuge auf Seite // Similar tools on page
463

Bitte Hinweise im Anhang beachten // Please read add. notes
ALL (Seite/Page 645), H01 (Seite/Page 646), H07 (Seite/Page 648)

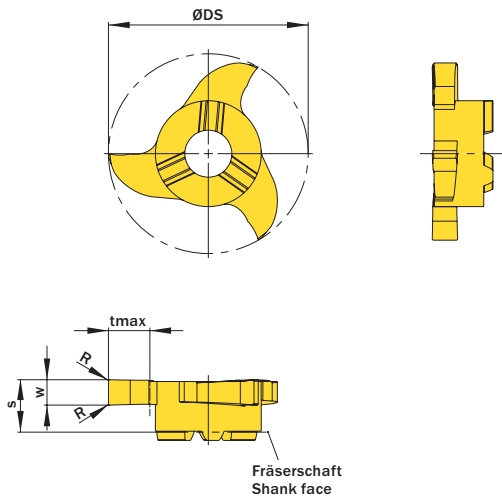
SP

HM

LM

Legende
Legend **650**

Scan QR-Code Oder besuchen Sie // Or Visit
www.simtek.info/cp/372



Fräserchaft
Shank face

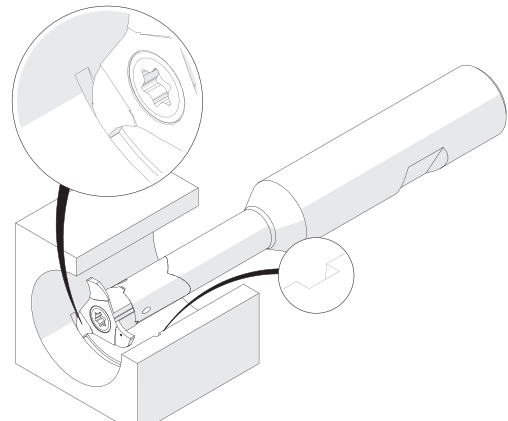


Illustration zeigt beispielhafte Anwendungsmöglichkeit mit ähnlichem Werkzeug.
 Image shows exemplary application possibility with similar tool.

Abbildung zeigt / Drawing shows: V22.0265.42 C

w ^{-0,02}	Nuttenbreite Nominal width of groove	R	ØDmin (Min.-Bohrung) ØDmin (min. bore)	Artikelnummer Part number	Webcode www.simtek.com/webcode	Unsere erste Wahl Our first choice	tmax	S	ØDS	ZEFP	Connectcode www.simtek.com/ccode	upd
mm	mm	mm	mm			P M K N S	mm	mm	mm			
1,44	1,3	0,1	22,0	V22.0130.41 C	AKE5	X808 HT42	4,5	5,7	21,7	3	VD12.0	upd
1,74	1,6	0,1	22,0	V22.0160.41 C	AKCG	X808 HT42	4,5	5,7	21,7	3	VD12.0	upd
1,99	1,85	0,2	22,0	V22.0185.42 C	AF6X	X808 HT42	4,5	5,7	21,7	3	VD12.0	upd
2,29	2,15	0,2	22,0	V22.0215.42 C	APU4	X808 HT42	4,5	5,7	21,7	3	VD12.0	upd
2,79	2,65	0,2	22,0	V22.0265.42 C	AG8P	X808 HT42	4,5	5,7	21,7	3	VD12.0	upd
3,29	3,15	0,2	22,0	V22.0315.42 C	AHWH	X808 HT42	4,5	5,7	21,7	3	VD12.0	upd
4,29	4,15	0,2	22,0	V22.0415.42 C	AJYP	X808 HT42	4,5	5,7	21,7	3	VD12.0	upd
5,29	5,15	0,2	22,0	V22.0515.42 C	ANZF	X808 HT42	4,5	5,7	21,7	3	VD12.0	upd

Bestellbeispiel // Order example: **V22.0130.41 C X808** (X808 = Schneidstoff // Grade)



V22. w, 1/100 mm, 4 Stellen/Digits . R, 1/100 mm, 3 Stellen/Digits Toleranz // Tolerance **C**
 Beispielartikelnummer // Example Part number: **V22.0179.030 XG C**

Allgemeines Nutfräsen

Nutfräsen gerader Nutformen.
Geeignet ab Bohrungsdurchmesser 22,0 mm.

General Groove Milling

General groove milling.
For use in bores as of minimum bore diameter 22,0 mm.

Schnittwerte (Start) // Cutting parameters (start)		
fzm 0,04 mm	hmax 0,05 mm	Vc Seite/Page 638
Passende Klemmhalter auf Seite // Suitable toolholders on page 556, 557, 558, 559, 560, 561, 562, 563, 564		
Vergleichbare Werkzeuge auf Seite // Similar tools on page 461		
Bitte Hinweise im Anhang beachten // Please read add. notes ALL (Seite/Page 645), H01 (Seite/Page 646), H05 (Seite/Page 648), H07 (Seite/Page 648)		

SP

Legende

HM

Legend

650

Scan
QR-Code

Oder besuchen Sie // Or Visit
www.simtek.info/cp/380

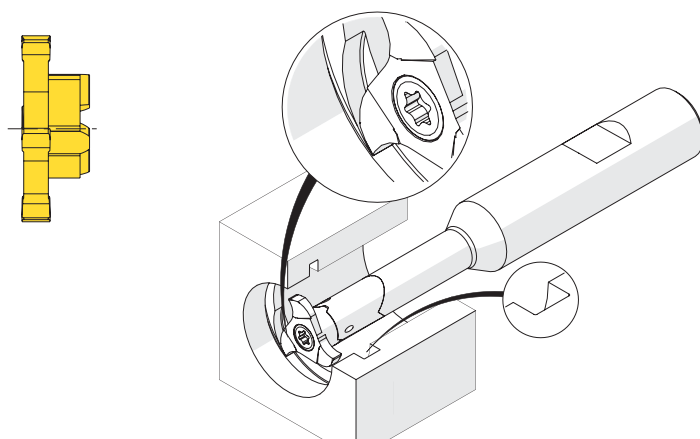
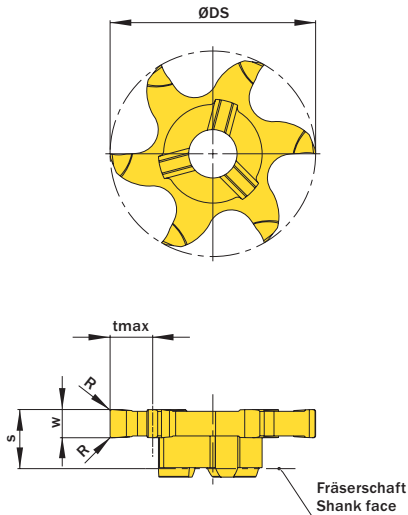


Illustration zeigt beispielhafte Anwendungsmöglichkeit mit ähnlichem Werkzeug.
Image shows exemplary application possibility with similar tool.

Abbildung zeigt / Drawing shows: V06.0300.020.22 G

w ^{+0,02}	R	ØDmin (Min. Bohrung) ØDmin (min. bore)	Artikelnummer Part number	Webcode www.simtek.com/webcode	Unsere erste Wahl Our first choice	tmax	S	ØDS	ZEFP	Connectcode www.simtek.com/code
mm	mm	mm			P M K N S	mm	mm	mm		
1,0	0,1	22,0	V06.0100.010.22 G	AGZW	X800 GT42	4,5	5,8	21,7	6	VD12.0
1,168	0,1	22,0	V06.0117.010.22 G	A6EF	X800 GT42	4,5	5,8	21,7	6	VD12.0 new incl
1,5	0,1	22,0	V06.0150.010.22 G	AGY6	X800 GT42	4,5	6,2	21,7	6	VD12.0
1,575	0,1	22,0	V06.0157.010.22 G	A6EH	X800 GT42	4,5	6,2	21,7	6	VD12.0 new incl
2,0	0,2	22,0	V06.0200.020.22 G	AFJQ	X800 GT42	4,5	6,2	21,7	6	VD12.0
2,388	0,2	22,0	V06.0238.020.22 G	A6EB	X800 GT42	4,5	6,2	21,7	6	VD12.0 new incl
2,5	0,2	22,0	V06.0250.020.22 G	AKJ5	X800 GT42	4,5	6,2	21,7	6	VD12.0
3,0	0,2	22,0	V06.0300.020.22 G	AFBB	X800 GT42	4,5	6,2	21,7	6	VD12.0
3,175	0,2	22,0	V06.0318.020.22 G	A6ED	X800 GT42	4,5	6,2	21,7	6	VD12.0 new incl
4,0	0,2	22,0	V06.0400.020.22 G	APZW	X800 GT42	4,5	6,2	21,7	6	VD12.0

Bestellbeispiel // Order example: **V06.0200.020.22 G X800** (X800 = Schneidstoff // Grade)



V06. w, 1, /100 mm, 4 Stellen/Digits . R, 1, /100 mm, 3 Stellen/Digits .22 Toleranz // Tolerance

Beispielartikelnummer // Example Part number: **V06.0179.030.22 XG**

simmill AX
simmill PMX
simmill PX
simmill SX
simmill UX
simmill VX
simmill H2
simmill K2
simmill MX
simmill OS
Index

Allgemeines Nutfräsen

Nutfräsen gerader Nutformen.
Geeignet ab Bohrungsdurchmesser 22,0 mm.

General Groove Milling

General groove milling.
For use in bores as of minimum bore diameter 22,0 mm.

Schnittwerte (Start) // Cutting parameters (start)		
f _{zm} 0,04 mm	h _{max} 0,05 mm	V _c Seite/Page 638
Passende Klemmhalter auf Seite // Suitable toolholders on page		
556, 557, 558, 559, 560, 561, 562, 563, 564		
Vergleichbare Werkzeuge auf Seite // Similar tools on page		
461		
Bitte Hinweise im Anhang beachten // Please read add. notes		
ALL (Seite/Page 645), H01 (Seite/Page 646), H07 (Seite/Page 648)		

SP Legende

HM Legend

650

Scan QR-Code

Oder besuchen Sie // Or Visit www.simtek.info/cp/373

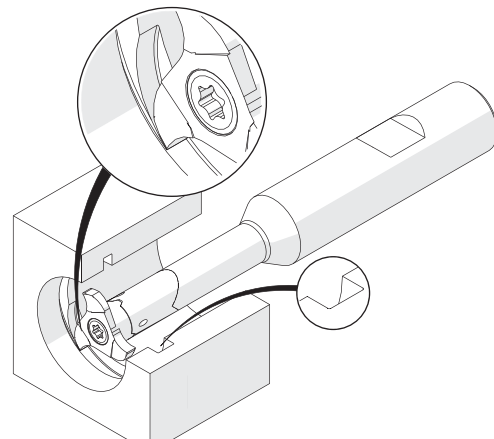
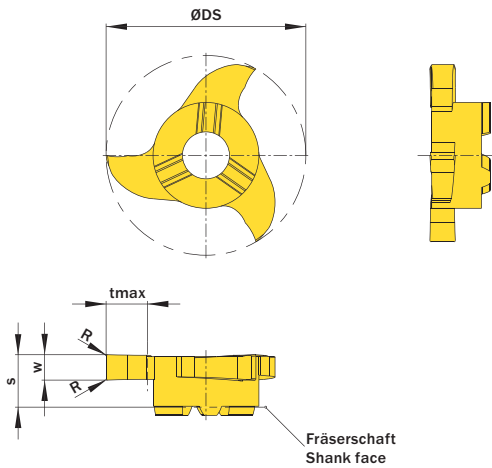


Illustration zeigt beispielhafte Anwendungsmöglichkeit mit ähnlichem Werkzeug.
Image shows exemplary application possibility with similar tool.

Abbildung zeigt / Drawing shows: V22.0250.02 G

w ^{+0,02}	R	ØDmin (Min. Bohrung) ØDmin (min. bore)	Artikelnummer Part number	Webcode www.simtek.com/webcode	Unsere erste Wahl Our first choice	tmax	S	ØDS	ZEFP	Connectcode www.simtek.com/code
mm	mm	mm			P M K N S	mm	mm			
1,0	0,1	22,0	V22.0100.01 G	AEQM	X800 GT42	4,5	5,7	21,7	3	VD12.0
1,5	0,2	22,0	V22.0150.02 G	AHH9	X800 GT42	4,5	5,7	21,7	3	VD12.0
1,575	0,2	22,0	V22.0157.02 G	ANQX	X800 GT42	4,5	5,7	21,7	3	VD12.0
2,0	0,2	22,0	V22.0200.02 G	ADNU	X800 GT42	4,5	5,7	21,7	3	VD12.0
2,388	0,2	22,0	V22.0239.02 G	AHMN	X800 GT42	4,5	5,7	21,7	3	VD12.0
2,5	0,2	22,0	V22.0250.02 G	AKKF	X800 GT42	4,5	5,7	21,7	3	VD12.0
3,0	0,2	22,0	V22.0300.02 G	ABXX	X800 GT42	4,5	5,7	21,7	3	VD12.0
3,175	0,2	22,0	V22.0318.02 G	AK1S	X800 GT42	4,5	5,7	21,7	3	VD12.0
3,175	0,4	22,0	V22.0318.04 G	AB1P	X800 GT42	4,5	5,7	21,7	3	VD12.0
3,5	0,2	22,0	V22.0350.02 G	AM6N	X800 GT42	4,5	5,7	21,7	3	VD12.0
3,556	0,2	22,0	V22.0356.02 G	AD90	X800 GT42	4,5	5,7	21,7	3	VD12.0
4,0	0,2	22,0	V22.0400.02 G	AF5N	X800 GT42	4,5	5,7	21,7	3	VD12.0
4,0	0,4	22,0	V22.0400.04 G	AGMH	X800 GT42	4,5	5,7	21,7	3	VD12.0
4,369	0,2	22,0	V22.0437.02 G	AHBP	X800 GT42	4,5	5,7	21,7	3	VD12.0
4,369	0,4	22,0	V22.0437.04 G	AEPH	X800 GT42	4,5	5,7	21,7	3	VD12.0
4,75	0,2	22,0	V22.0475.02 G	ADF7	X800 GT42	4,5	5,7	21,7	3	VD12.0
5,0	0,2	22,0	V22.0500.02 G	AZCE	X800 GT42	4,5	5,7	21,7	3	VD12.0
6,35	0,2	22,0	V22.0635.02 G	A1JU	X800 GT42	4,5	9,3	21,7	3	VD12.0

Bestellbeispiel // Order example: **V22.0300.02 G X800** (X800 = Schneidstoff // Grade)

simtek individual

V22. w. 1/100 mm, 4 Stellen/Digits . R. 1/100 mm, 3 Stellen/Digits Toleranz // Tolerance

Beispielartikelnummer // Example Part number: **V22.0179.030 XG**

Allgemeines Nutfräsen, für weiche Schnitte

Nutfräsen gerader Nutformen. Weiches Eintauchen in den Werkstückstoff und bessere Oberflächen durch optimierte Schneidengeometrie. Geeignet ab Bohrungsdurchmesser 22,0 mm.

General Groove Milling, for smooth cuts

General groove milling. With a new cutting edge geometry for very smooth cuts and better surface quality. For use in bores as of minimum bore diameter 22,0 mm.

Schnittwerte (Start) // Cutting parameters (start)		
fzm 0,04 mm	hmax 0,05 mm	Vc Seite/Page 638
Passende Klemmhalter auf Seite // Suitable toolholders on page 556, 557, 558, 559, 560, 561, 562, 563, 564		
Vergleichbare Werkzeuge auf Seite // Similar tools on page 461		
Bitte Hinweise im Anhang beachten // Please read add. notes ALL (Seite/Page 645), H01 (Seite/Page 646), H05 (Seite/Page 648), H07 (Seite/Page 648)		

SP Legende
HM Legend

650

Scan QR-Code Oder besuchen Sie // Or Visit
www.simtek.info/cp/1124

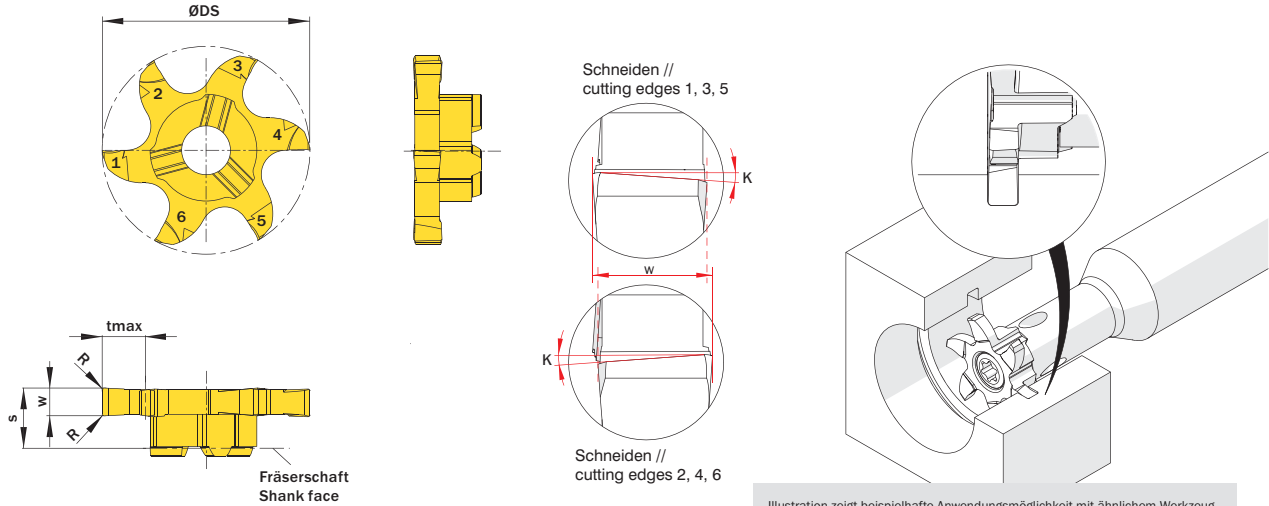


Abbildung zeigt / Drawing shows: V06.0300.020.22 GY

w ^{+0,02}	Nuttenbreite Nominal width of groove	R	ØDmin (Min. Bohrung) ØDmin (min. bore)	Artikelnummer Part number	Webcode www.simtek.com/webcode	Unsere erste Wahl Our first choice		tmax	S	ØDS	ZEFP	Connectcode www.simtek.com/ccode
						P M K N S						
2,0	-	0,2	22,0	V06.0200.020.22 GY	A0ZB	X800	GT42	4,5	6,2	21,7	6	VD12.0
2,5	-	0,2	22,0	V06.0250.020.22 GY	AYFX	X800	GT42	4,5	6,2	21,7	6	VD12.0
3,0	-	0,2	22,0	V06.0300.020.22 GY	AYFY	X800	GT42	4,5	6,2	21,7	6	VD12.0
4,0	-	0,2	22,0	V06.0400.020.22 GY	AYFZ	X800	GT42	4,5	6,2	21,7	6	VD12.0

Bestellbeispiel // Order example: **V06.0250.020.22 GY X800** (X800 = Schneidstoff // Grade)

simmill AX
simmill PMX
simmill PX
simmill SX
simmill UX
simmill VX
simmill H2
simmill K2
simmill MX
simmill OS
Index

Allgemeines Nutfräsen, für weiche Schnitte

Nutfräsen gerader Nutformen. Weiches Eintauchen in den Werkstückstoff und bessere Oberflächen durch optimierte Schneidengeometrie. Geeignet ab Bohrungsdurchmesser 25,0 mm.

General Groove Milling, for smooth cuts

General groove milling. With a new cutting edge geometry for very smooth cuts and better surface quality. For use in bores as of minimum bore diameter 25,0 mm.

Schnittwerte (Start) // Cutting parameters (start)		
fzm 0,04 mm	hmax 0,05 mm	Vc Seite/Page 638

Passende Klemmhalter auf Seite // Suitable toolholders on page
556, 557, 558, 559, 560, 561, 563

Vergleichbare Werkzeuge auf Seite // Similar tools on page
461

Bitte Hinweise im Anhang beachten // Please read add. notes

ALL (Seite/Page 645), H01 (Seite/Page 646), H05 (Seite/Page 648), H07 (Seite/Page 648)



SP Legende
HM Legend
650

Scan QR-Code Oder besuchen Sie // Or Visit
www.simtek.info/cp/1135

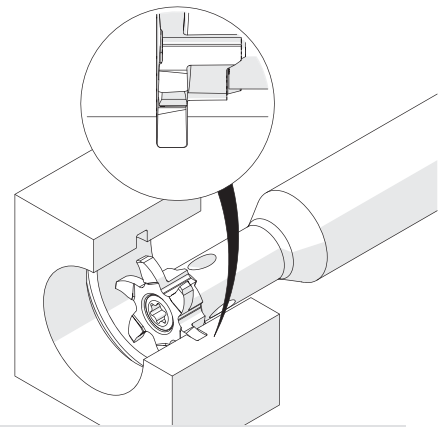
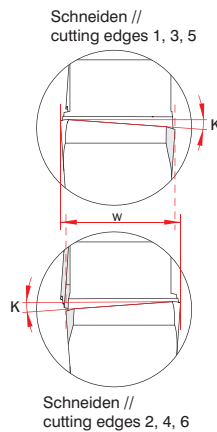
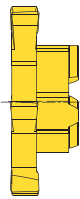
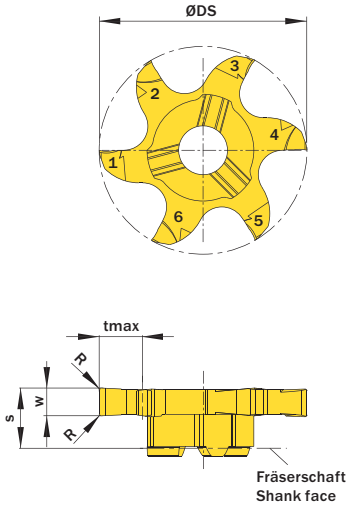


Illustration zeigt beispielhafte Anwendungsmöglichkeit mit ähnlichem Werkzeug.
 Image shows exemplary application possibility with similar tool.

Abbildung zeigt / Drawing shows: V06.0300.020.22 GY

w ^{+0,02}	Nuttenbreite Nominal width of groove	R	ØDmin (Min. Bohrung) ØDmin (min. bore)	Artikelnummer Part number	Webcode www.simtek.com/webcode	Unsere erste Wahl Our first choice	tmax	S	ØDS	ZEFP	Connectcode www.simtek.com/code
mm	mm	mm	mm			P M K N S	mm	mm	mm		
▼ ØDmin (Min. Bohrung) // ØDmin (min. bore) = 25,0 mm											
2,5	-	0,2	25,0	V06.0250.020.25 GY	AZD0	X800 GT42	5,0	6,4	24,8	6	VD14.0 VD14.3
2,76	2,65	0,2	25,0	V06.0265.020.25 GY	AZD1	X800 GT42	5,0	6,4	24,8	6	VD14.0 VD14.3
3,0	-	0,2	25,0	V06.0300.020.25 GY	AZD2	X800 GT42	5,0	6,4	24,8	6	VD14.0 VD14.3
4,0	-	0,2	25,0	V06.0400.020.25 GY	AZD3	X800 GT42	5,0	6,4	24,8	6	VD14.0 VD14.3
5,0	-	0,2	25,0	V06.0500.020.25 GY	AZD4	X800 GT42	5,0	6,4	24,8	6	VD14.0 VD14.3
6,0	-	0,2	25,0	V06.0600.020.25 GY	AZD5	X800 GT42	5,0	6,4	24,8	6	VD14.0 VD14.3
▼ ØDmin (Min. Bohrung) // ØDmin (min. bore) = 28,0 mm											
1,71	1,6	0,1	28,0	V06.0160.010.28 GY	A4XZ	X800 GT42	6,5	6,2	27,7	6	VD14.0 VD14.3 new
2,0	-	0,2	28,0	V06.0200.020.28 GY	A4X1	X800 GT42	6,5	6,2	27,7	6	VD14.0 VD14.3 new
2,5	-	0,2	28,0	V06.0250.020.28 GY	AYJC	X800 GT42	6,5	6,2	27,7	6	VD14.0 VD14.3
2,76	2,65	0,2	28,0	V06.0265.020.28 GY	AYF8	X800 GT42	6,5	6,2	27,7	6	VD14.0 VD14.3
3,0	-	0,2	28,0	V06.0300.020.28 GY	AYF9	X800 GT42	6,5	6,2	27,7	6	VD14.0 VD14.3
3,5	-	0,2	28,0	V06.0350.020.28 GY	A36F	X800 GT42	6,5	6,2	27,7	6	VD14.0 VD14.3 new
4,0	-	0,2	28,0	V06.0400.020.28 GY	AYGA	X800 GT42	6,5	6,2	27,7	6	VD14.0 VD14.3
5,0	-	0,2	28,0	V06.0500.020.28 GY	AYGB	X800 GT42	6,5	6,2	27,7	6	VD14.0 VD14.3
6,0	-	0,2	28,0	V06.0600.020.28 GY	AYGC	X800 GT42	6,5	6,2	27,7	6	VD14.0 VD14.3

Bestellbeispiel // Order example: **V06.0400.020.28 GY X800** (X800 = Schneidstoff // Grade)

Allgemeines Nutfräsen, für weiche Schnitte

Nutfräsen gerader Nutformen. Weiches Eintauchen in den Werkstückstoff und bessere Oberflächen durch optimierte Schneidengeometrie. Geeignet ab Bohrungsdurchmesser 35,0 mm.

General Groove Milling, for smooth cuts

General groove milling. With a new cutting edge geometry for very smooth cuts and better surface quality. For use in bores as of minimum bore diameter 35,0 mm.

Schnittwerte (Start) // Cutting parameters (start)		
fzm 0,04 mm	hmax 0,05 mm	Vc Seite/Page 638
Passende Klemmhalter auf Seite // Suitable toolholders on page 556, 557, 558, 559, 560, 561, 562, 563, 564		
Vergleichbare Werkzeuge auf Seite // Similar tools on page 461		
Bitte Hinweise im Anhang beachten // Please read add. notes ALL (Seite/Page 645), H01 (Seite/Page 646), H05 (Seite/Page 648), H07 (Seite/Page 648)		

SP

Legende

HM

Legend

650

Scan QR-Code Oder besuchen Sie // Or Visit
www.simtek.info/cp/1136

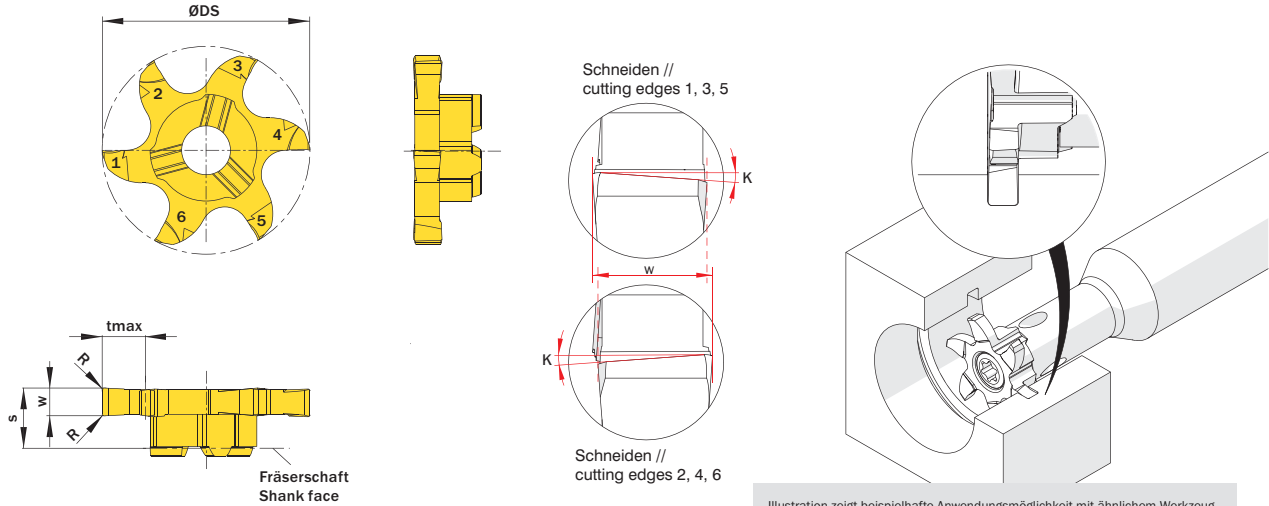


Abbildung zeigt / Drawing shows: V06.0300.020.22 GY

w ±0.02	R	ØDmin (Min. Bohrung) ØDmin (min. bore)	Artikelnummer Part number	Webcode www.simtek.com/webcode	Unsere erste Wahl Our first choice	tmax	S ±0.02	ØDS	ZEFP	Connectcode www.simtek.com/code
mm	mm	mm			P M K N S	mm	mm	mm		
▼ ØDmin (Min. Bohrung) // ØDmin (min. bore) = 35,0 mm										
2,0	0,2	35,0	V06.0200.020.35 GY	AYF5	X800 GT42	10,0	6,2	34,7	6	VD14.0 VD14.3
2,5	0,2	35,0	V06.0250.020.35 GY	AYF6	X800 GT42	10,0	6,2	34,7	6	VD14.0 VD14.3
3,0	0,2	35,0	V06.0300.020.35 GY	AYF7	X800 GT42	10,0	6,2	34,7	6	VD14.0 VD14.3
▼ ØDmin (Min. Bohrung) // ØDmin (min. bore) = 37,0 mm										
1,5	0,1	37,0	V06.0150.010.37 GY	AZDZ	X800 GT42	12,0	6,2	36,7	6	VD12.0
2,0	0,2	37,0	V06.0200.020.37 GY	AX0H	X800 GT42	12,0	6,2	36,7	6	VD12.0

Bestellbeispiel // Order example: **V06.0300.020.35 GY X800** (X800 = Schneidstoff // Grade)

simmill AX
simmill PMX
simmill PX
simmill SX
simmill UX
simmill VX
simmill H2
simmill K2
simmill MX
simmill OS
Index

Fräsen von Sicherungsringnuten mit Fassung

Fräsen von Sicherungsringnuten mit Nutaußenkantenfasung.
 Geeignet ab Bohrungsdurchmesser 22,0 mm.

Circlip Ring Groove Milling with chamfering

Circlip ring groove milling with chamfering.
 For use in minimum bore diameter 22,0 mm.

Schnittwerte (Start) // Cutting parameters (start)

fzm 0,04 mm	hmax 0,05 mm	Vc Seite/Page 638
-----------------------	------------------------	-----------------------------

Passende Klemmhalter auf Seite // Suitable toolholders on page
556, 557, 558, 559, 560, 561, 562, 563, 564

Bitte Hinweise im Anhang beachten // Please read add. notes

ALL (Seite/Page 645), H01 (Seite/Page 646), H07 (Seite/Page 648)



SP Legende
HM Legend
650

Scan QR-Code Oder besuchen Sie // Or Visit
www.simtek.info/cp/419

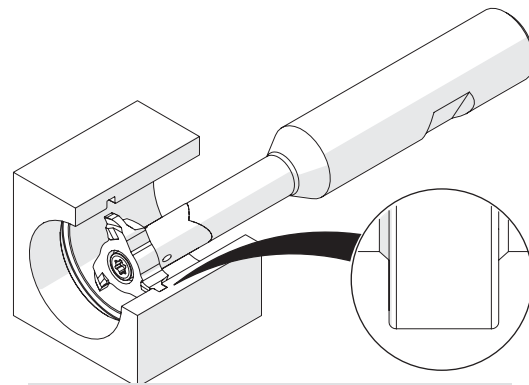
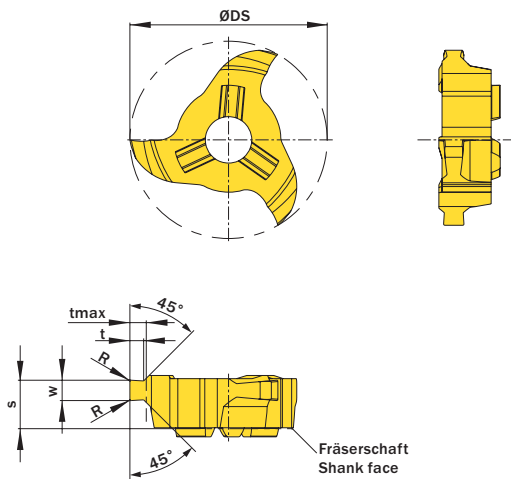


Illustration zeigt beispielhafte Anwendungsmöglichkeit mit ähnlichem Werkzeug.
 Image shows exemplary application possibility with similar tool.

Abbildung zeigt / Drawing shows: V22.2215.35 F

w ^{-0,02}	Nutnenbreite Nominal width of groove	R	ØDmin (Min. Bohrung) ØDmin (min. bore)	Artikelnummer Part number	Webcode www.simtek.com/webcode	Unsere erste Wahl Our first choice	t	tmax	S	ØDS	ZEFP	Connectcode www.simtek.com/ccode
mm	mm	mm	mm			P M K N S	mm	mm	mm	mm		
1,21	1,1	-	22,0	V22.1105.30 F	ADTP	X800 G742	0,49	0,5	5,1	21,7	3	VD11.3 VD11.5 VD12.0 VD12.7 VD13.5 VD14.0 VD14.3 VD15.0 VD16.0
1,41	1,3	-	22,0	V22.1307.30 F	AJDV	X800 G742	0,67	0,7	5,2	21,7	3	
1,41	1,3	-	22,0	V22.1308.30 F	ADZF	X800 G742	0,83	0,85	5,2	21,7	3	
1,71	1,6	-	22,0	V22.1609.35 F	AKYN	X800 G742	0,83	0,85	5,1	21,7	3	
1,71	1,6	-	22,0	V22.1610.35 F	AKAE	X800 G742	0,97	1,0	5,1	21,7	3	
1,96	1,85	0,15	22,0	V22.1812.35 F	AA3W	X800 G742	1,23	1,25	5,2	21,7	3	
2,26	2,15	0,15	22,0	V22.2215.35 F	APWV	X800 G742	1,47	1,5	5,3	21,7	3	
2,76	2,65	0,15	22,0	V22.2616.45 F	AAAZ	X800 G742	1,47	1,5	5,1	21,7	3	
2,76	2,65	0,15	22,0	V22.2617.45 F	AEW7	X800 G742	1,72	1,75	5,1	21,7	3	
3,26	3,15	0,2	22,0	V22.3118.45 F	AFJ7	X800 G742	1,72	1,75	5,3	21,7	3	
4,26	4,15	0,2	22,0	V22.4120.55 F	AD5S	X800 G742	1,97	2,0	5,3	21,7	3	
4,26	4,15	0,2	22,0	V22.4125.55 F	AE8V	X800 G742	2,47	2,5	5,3	21,7	3	

Bestellbeispiel // Order example: **V22.1609.35 F X800** (X800 = Schneidstoff // Grade)

Allgemeines Nutfräsen in Leichtmetall

Nutfräsen gerader Nutformen in Bohrungen ab Bohrungsdurchmesser 22,0 mm. Durch hochpositive Schneidengeometrie besonders geeignet für Leichtmetalle.

General Groove Milling in light alloys

General groove milling in bores as of bore diameter 22,0 mm. High positive rake angle for use in light alloys.

Schnittwerte (Start) // Cutting parameters (start)		
fzm 0,04 mm	hmax 0,05 mm	Vc Seite/Page 638
Passende Klemmhalter auf Seite // Suitable toolholders on page 556, 557, 558, 559, 560, 561, 562, 563, 564		
Vergleichbare Werkzeuge auf Seite // Similar tools on page 462		
Bitte Hinweise im Anhang beachten // Please read add. notes ALL (Seite/Page 645), H01 (Seite/Page 646), H07 (Seite/Page 648)		

SP
HM

LM

Legende
Legend **650**

Scan QR-Code Oder besuchen Sie // Or Visit
www.simtek.info/cp/374

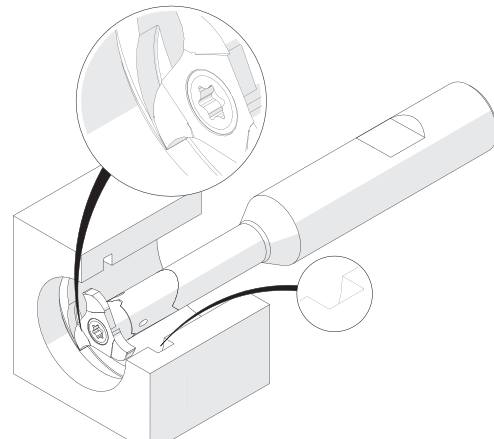
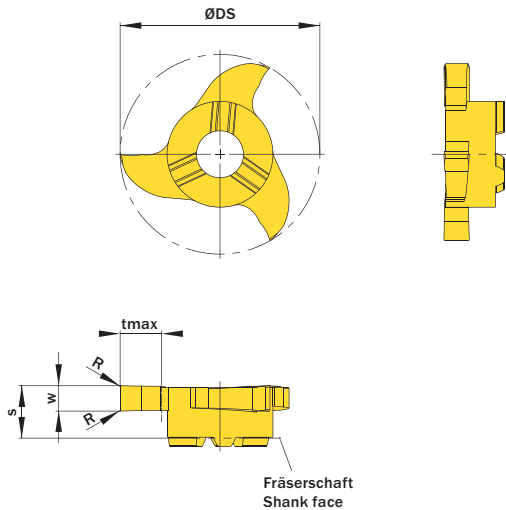


Illustration zeigt beispielhafte Anwendungsmöglichkeit mit ähnlichem Werkzeug.
 Image shows exemplary application possibility with similar tool.

Abbildung zeigt / Drawing shows: V22.0250.42 C

w ^{+0,02}	R	ØDmin (Min. Bohrung) ØDmin (min. bore)	Artikelnummer Part number	Webcode www.simtek.com/webcode	Unsere erste Wahl Our first choice	tmax	S	ØDS	ZEFP	Connectcode www.simtek.com/code
mm	mm	mm			P M K N S	mm	mm	mm		
1,5	0,2	22,0	V22.0150.42 C	ANDN	X808 HT42	4,5	5,7	21,7	3	VD12.0
2,0	0,2	22,0	V22.0200.42 C	ANC3	X808 HT42	4,5	5,7	21,7	3	VD12.0
2,5	0,2	22,0	V22.0250.42 C	AH0W	X808 HT42	4,5	5,7	21,7	3	VD12.0
3,0	0,2	22,0	V22.0300.42 C	AHME	X808 HT42	4,5	5,7	21,7	3	VD12.0
4,0	0,2	22,0	V22.0400.42 C	ABUK	X808 HT42	4,5	5,7	21,7	3	VD12.0

Bestellbeispiel // Order example: **V22.0300.42 C X808** (X808 = Schneidstoff // Grade)

simtek individual V22. w, 1/100 mm, 4 Stellen/Digits . R, 1/100 mm, 3 Stellen/Digits Toleranz // Tolerance C
 Beispielartikelnummer // Example Part number: **V22.0179.030 XG C**

simmill AX
simmill PMX
simmill PX
simmill SX
simmill UX
simmill VX
simmill H2
simmill K2
simmill MX
simmill OS
Index

Fräsen von Vollradiusnuten

Nutfräsen runder Nutformen.
Geeignet ab Bohrungsdurchmesser 22,0 mm.

Full Radius Groove Milling

Full radius groove milling.
For use in bores as of minimum bore diameter 22,0 mm.

Schnittwerte (Start) // Cutting parameters (start)

fzm 0,04 mm	hmax 0,05 mm	Vc Seite/Page 638
-----------------------	------------------------	-----------------------------

Passende Klemmhalter auf Seite // Suitable toolholders on page
556, 557, 558, 559, 560, 561, 562, 563, 564

Vergleichbare Werkzeuge auf Seite // Similar tools on page
465

Bitte Hinweise im Anhang beachten // Please read add. notes

ALL (Seite/Page 645), H01 (Seite/Page 646), H07 (Seite/Page 648)



SP Legende
HM Legend
650

Scan QR-Code Oder besuchen Sie // Or Visit
www.simtek.info/cp/403

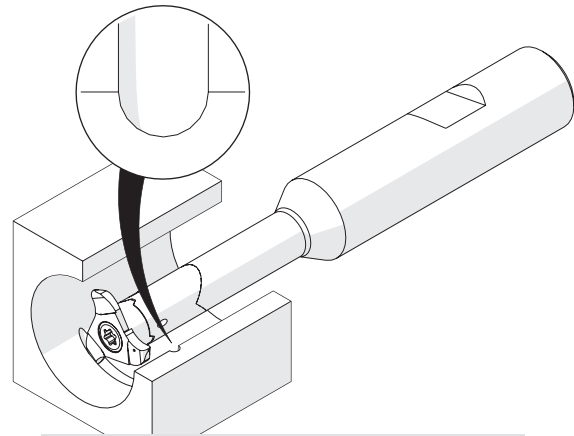
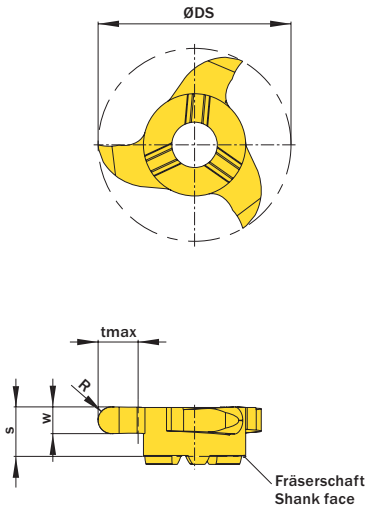


Illustration zeigt beispielhafte Anwendungsmöglichkeit mit ähnlichem Werkzeug.
Image shows exemplary application possibility with similar tool.

Abbildung zeigt / Drawing shows: V22.0015.30 V

R	w ^{+0,03}	ØDmin (Min. Bohrung) ØDmin (min. bore)	Artikelnummer Part number	Webcode www.simtek.com/webcode	Unsere erste Wahl Our first choice	tmax	S	ØDS	ZEFP	Connectcode www.simtek.com/code
mm	mm	mm			P M K N S	mm	mm	mm		
0,5	1,0	22,0	V22.0005.10 V	AD2W	X800 GT42	4,5	5,8	21,7	3	VD12.0
0,8	1,6	22,0	V22.0008.16 V	AFEE	X800 GT42	4,5	5,8	21,7	3	VD12.0
1,0	2,0	22,0	V22.0010.20 V	ABHY	X800 GT42	4,5	5,8	21,7	3	VD12.0
1,2	2,4	22,0	V22.0012.24 V	ACH9	X800 GT42	4,5	5,8	21,7	3	VD12.0
1,4	2,8	22,0	V22.0014.28 V	ADDY	X800 GT42	4,5	5,8	21,7	3	VD12.0
1,5	3,0	22,0	V22.0015.30 V	AF96	X800 GT42	4,5	5,8	21,7	3	VD12.0
1,588	3,175	22,0	V22.0062.12 V	A3T5	X800 GT42	4,5	5,8	21,7	3	VD12.0 <small>new inch</small>
2,2	4,4	22,0	V22.0022.44 V	AC2Y	X800 GT42	4,5	5,8	21,7	3	VD12.0
2,381	4,762	22,0	V22.0024.48 V	A38X	X800 GT42	4,5	5,8	21,7	3	VD12.0 <small>new inch</small>
2,5	5,0	22,0	V22.0025.50 V	AH32	X800 GT42	4,5	5,8	21,7	3	VD12.0
3,2	6,4	22,0	V22.0032.64 V	A1E0	X800 GT42	4,5	9,3	21,7	3	VD12.0
1,588	3,175	25,0	V25.0016.318 V	A6U9	X800 GT42	5,0	6,6	24,7	3	VD12.0 <small>new inch</small>
1,588	3,175	28,0	V28.0016.318 V	A61V	X800 GT42	6,5	6,6	27,7	3	VD12.0 <small>new inch</small>
3,175	6,35	28,0	V28.0032.635 V	A6X7	X800 GT42	6,5	6,6	27,7	3	VD12.0 <small>new inch</small>

Bestellbeispiel // Order example: **V22.0014.28 V X800** (X800 = Schneidstoff // Grade)

Metrisches ISO-Gewindefräsen, Vollprofil

Fräsen von metrischen ISO-Gewinden, Vollprofil.

Thread milling, metric ISO-Thread, full profile

Thread milling of metric ISO-threads, full profile.

Schnittwerte (Start) // Cutting parameters (start)		
fzm 0,04 mm	hmax 0,05 mm	Vc Seite/Page 638
Passende Klemmhalter auf Seite // Suitable toolholders on page 556, 557, 558, 559, 560, 561, 562, 563, 564		
Vergleichbare Werkzeuge auf Seite // Similar tools on page 467		
Bitte Hinweise im Anhang beachten // Please read add. notes ALL (Seite/Page 645), H03 (Seite/Page 647), H05 (Seite/Page 648), H06 (Seite/Page 648), H07 (S./P. 648)		

SP Legende

HM Legend

650

Scan QR-Code Oder besuchen Sie // Or Visit
www.simtek.info/cp/417

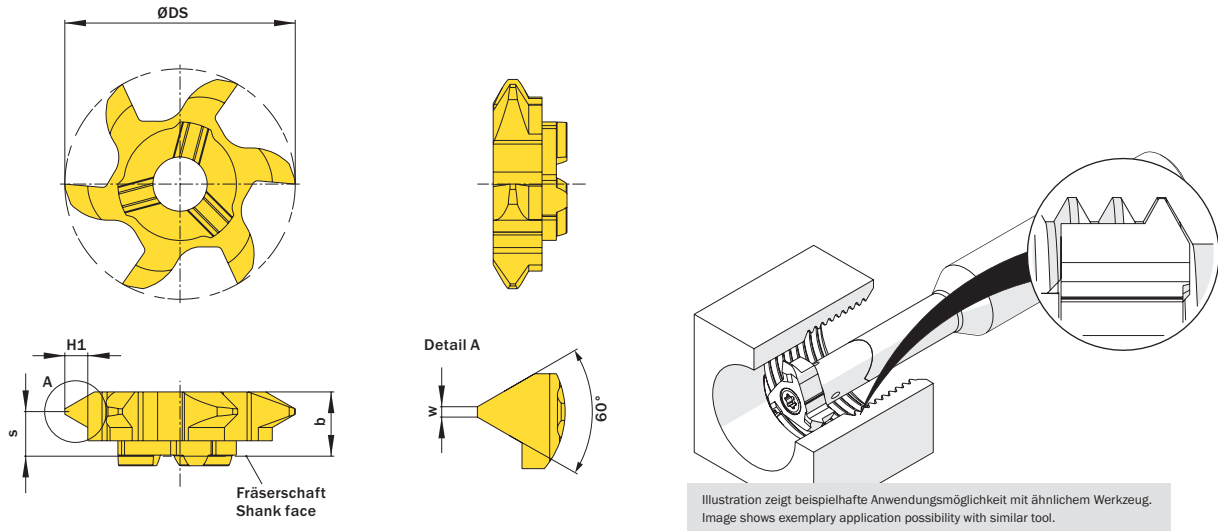


Illustration zeigt beispielhafte Anwendungsmöglichkeit mit ähnlichem Werkzeug.
 Image shows exemplary application possibility with similar tool.

Abbildung zeigt / Drawing shows: V06.2140.02.22 M

Ab Gewindegröße As of thread size	Ab Gewindennenn- messer // As of nominal thread diameter		Steigung (von) Pitch (as of)	Artikelnummer Part number	Webcode www.simtek.com/webcode	Unsere erste Wahl Our first choice		b	S	w	ØDS	ZEFP	Connectcode www.simtek.com/ccode
	mm	H1				P	K						
M27	25,86	0,81	1,5	V06.0815.02.22 M	AQ1C	X800	G742	6,2	5,3	0,19	21,7	6	
M30	27,1	0,95	1,75	V06.0917.02.22 M	AQ1D	X800	G742	6,2	5,2	0,22	21,7	6	VD11.3 VD11.5 VD12.0
M30	28,4	1,08	2,0	V06.1020.02.22 M	AQ1E	X800	G742	6,2	5,1	0,25	21,7	6	VD12.7 VD13.5 VD14.0
M33	30,95	1,62	3,0	V06.1630.02.22 M	AQ1F	X800	G742	6,2	4,8	0,37	21,7	6	VD14.3 VD15.0 VD16.0
M36	33,2	2,16	4,0	V06.2140.02.22 M	AQ1G	X800	G742	6,2	4,4	0,5	21,7	6	

Bestellbeispiel // Order example: **V06.0815.02.22 M X800** (X800 = Schneidstoff // Grade)

simmill AX
simmill PMX
simmill PX
simmill SX
simmill UX
simmill VX
simmill H2
simmill K2
simmill MX
simmill OS
Index

Metrisches ISO-Gewindefräsen, Vollprofil

Fräsen von metrischen ISO-Gewinden, Vollprofil.

Thread milling, metric ISO-Thread, full profile

Thread milling of metric ISO-threads, full profile.

Schnittwerte (Start) // Cutting parameters (start)		
fzm	hmax	Vc
0,04 mm	0,05 mm	Seite/Page 638

Passende Klemmhalter auf Seite // Suitable toolholders on page
556, 557, 558, 559, 560, 561, 562, 563, 564

Vergleichbare Werkzeuge auf Seite // Similar tools on page
467

Bitte Hinweise im Anhang beachten // Please read add. notes
ALL (Seite/Page 645), H06 (Seite/Page 648), H07 (Seite/Page 648)

SP Legende
HM Legend

650

Scan QR-Code Oder besuchen Sie // Or Visit www.simtek.info/cp/416

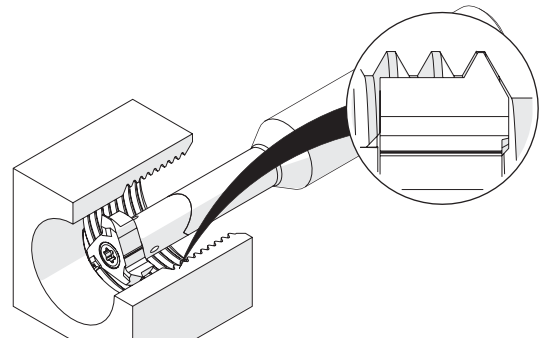
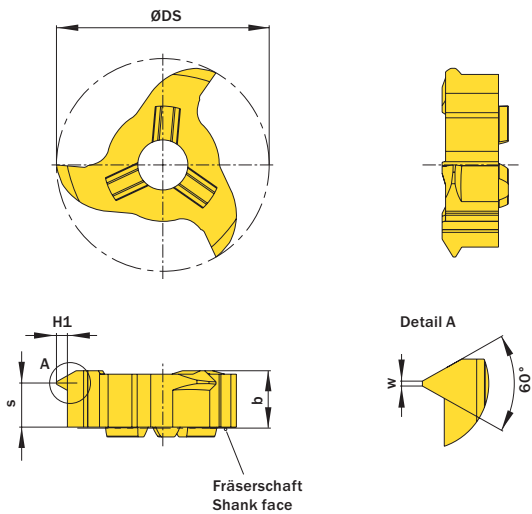


Illustration zeigt beispielhafte Anwendungsmöglichkeit mit ähnlichem Werkzeug.
 Image shows exemplary application possibility with similar tool.

Abbildung zeigt / Drawing shows: V22.1020.02 M

Ab Gewindegröße As of thread size	Ab Gewindegewinde As of nominal thread diameter		Steigung (von) Pitch (as of)	Artikelnummer Part number	Webcode www.simtek.com/webcode	Unsere erste Wahl Our first choice		b	S	w	ØDS	ZEFP	Connectcode www.simtek.com/code
	mm	H1				P	S						
M27	25,86	0,81	1,5	V22.0815.02 M	AA28	X800	G742	5,85	4,8	0,19	21,7	3	VD11.3 VD11.5 VD12.0 VD12.7 VD13.5 VD14.0 VD14.3 VD15.0 VD16.0
M30	27,1	0,95	1,75	V22.0917.02 M	AD26	X800	G742	5,85	4,7	0,22	21,7	3	
M30	28,4	1,08	2,0	V22.1020.02 M	APM9	X800	G742	5,85	4,6	0,25	21,7	3	
M33	30,95	1,62	3,0	V22.1630.02 M	ADAA	X800	G742	5,85	4,3	0,37	21,7	3	
M33	32,1	1,89	3,5	V22.1835.02 M	AHUY	X800	G742	5,85	4,1	0,43	21,7	3	
M36	33,2	2,16	4,0	V22.2140.02 M	AD70	X800	G742	5,85	3,9	0,5	21,7	3	
M36	34,25	2,43	4,5	V22.2445.02 M	AEFA	X800	G742	5,85	3,7	0,56	21,7	3	

Bestellbeispiel // Order example: **V22.1835.02 M X800** (X800 = Schneidstoff // Grade)

Metrisches ISO-Gewindfräsen, Teilprofil

Ausgelegt als Mehrbereichswerkzeuge. Die angegebene „Steigung (von)“ ist normgerecht. Die „Steigung (bis)“ kann ebenfalls realisiert werden. Vgl. Hinweistexte.

Thread milling, metric ISO-Thread, partial profile

Multi-purpose milling inserts. The given „Pitch (as of)“ is conforming to standards. The „Pitch (up to)“ is possible too at the expense of conformity. Please read additional notes.

Schnittwerte (Start) // Cutting parameters (start)		
fzm 0,04 mm	hmax 0,05 mm	Vc Seite/Page 638
Passende Klemmhalter auf Seite // Suitable toolholders on page 556, 557, 558, 559, 560, 561, 562, 563, 564		
Vergleichbare Werkzeuge auf Seite // Similar tools on page 466		
Bitte Hinweise im Anhang beachten // Please read add. notes ALL (Seite/Page 645), H03 (Seite/Page 647), H04 (Seite/Page 648), H05 (Seite/Page 648), H07 (S./P. 648)		

SP Legende
Legend

HM Legende
Legend

Scan
QR-Code

650

Oder besuchen Sie // Or Visit
www.simtek.info/cp/397

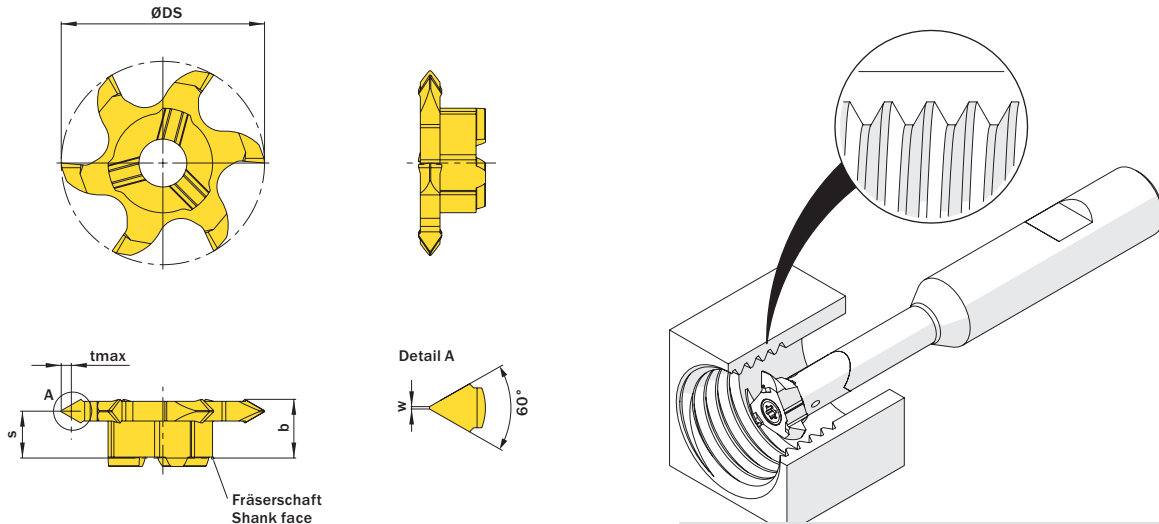


Abbildung zeigt / Drawing shows: V06.0720.01.22 M

Illustration zeigt beispielhafte Anwendungsmöglichkeit mit ähnlichem Werkzeug.
 Image shows exemplary application possibility with similar tool.

Ab Gewindgröße As of thread size	Steigung (von) Pitch (as of)	Steigung (bis) Pitch (up to)	Artikelnummer Part number	Webcode www.simtek.com/webcode	Unsere erste Wahl Our first choice		b	S	w	tmax	ØDS	ZEFP	Connectcode www.simtek.com/ccode		
					PM	KN							S	VD11.3	VD11.5
M27	1,0	2,0	V06.0720.01.22 M	AJ2A	X800	GT42	6,2	5,1	0,12	1,25	21,7	6	VD11.3	VD11.5	VD12.0
M27	2,0	4,5	V06.2545.01.22 M	AM1S	X800	GT42	6,05	4,2	0,25	2,71	21,7	6	VD12.7	VD13.5	VD14.0
													VD14.3	VD15.0	VD16.0

Bestellbeispiel // Order example: **V06.2545.01.22 M X800** (X800 = Schneidstoff // Grade)

Bitte beachten Sie die zusätzlichen Hinweise zu den Mehrbereichswerkzeugen im Infobereich rechts oben.

Please read the additional notes mentioned in the information area on the top right corner of this page.

Die angegebene Gewindgrößeneignung bezieht sich auf die Startsteigung.

The mentioned thread size „As of thread size“ is based on the starting pitch.

Mehr Infos zu den **Mehrbereichswerkzeugen** und deren **Gewindgrößeneignung** finden Sie auf Seite 649

More information about the **multi-purpose thread milling tools** and the **thread size suitability** can be found on page 649

Metrisches ISO-Gewindefräsen, Teilprofil

Ausgelegt als Mehrbereichswerkzeuge. Die angegebene „Steigung (von)“ ist normgerecht. Die „Steigung (bis)“ kann ebenfalls realisiert werden. Vgl. Hinweistexte.

Thread milling, metric ISO-Thread, partial profile

Multi-purpose milling inserts. The given „Pitch (as of)“ is conforming to standards. The „Pitch (up to)“ is possible too at the expense of conformity. Please read additional notes.

Schnittwerte (Start) // Cutting parameters (start)		
fzm 0,04 mm	hmax 0,05 mm	Vc Seite/Page 638

Passende Klemmhalter auf Seite // Suitable toolholders on page
556, 557, 558, 559, 560, 561, 562, 563, 564

Vergleichbare Werkzeuge auf Seite // Similar tools on page
466

Bitte Hinweise im Anhang beachten // Please read add. notes

ALL (Seite/Page 645), H03 (Seite/Page 647), H04 (Seite/Page 648), H07 (Seite/Page 648)



SP Legende
HM Legend

650



Scan
 QR-Code

Oder besuchen Sie // Or Visit
www.simtek.info/cp/396

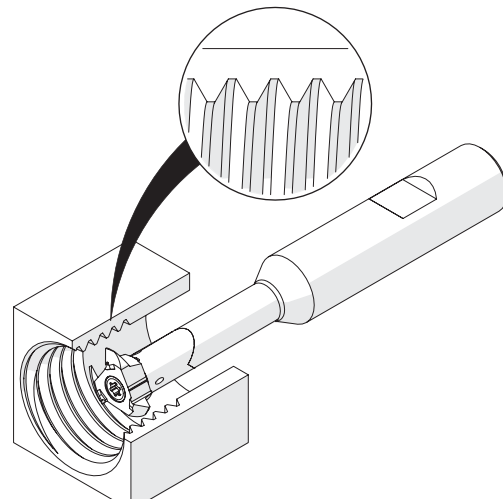
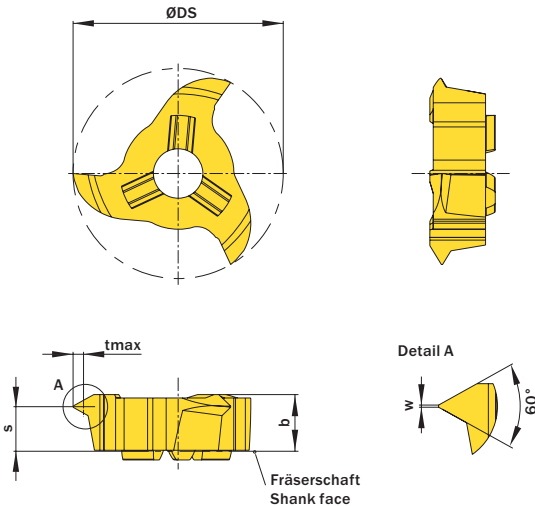


Illustration zeigt beispielhafte Anwendungsmöglichkeit mit ähnlichem Werkzeug.
 Image shows exemplary application possibility with similar tool.

Abbildung zeigt / Drawing shows: V22.0720.01 M

Ab Gewindegröße As of thread size	Steigung (von) Pitch (as of)	Steigung (bis) Pitch (up to)	Artikelnummer Part number	Webcode www.simtek.com/webcode	Unsere erste Wahl Our first choice		b	S	w	tmax	ØDS	ZEFP	Connectcode www.simtek.com/ccode
					PMKN	S							
M27	1,0	2,0	V22.0720.01 M	ABS8	X800	GT42	5,85	4,6	0,12	1,19	21,7	3	
M27	1,5	2,75	V22.0815.01 M	AA9K	X800	GT42	5,85	4,5	0,18	1,62	21,7	3	VD11.3 VD11.5 VD12.0 VD12.7 VD13.5 VD14.0
M27	2,0	3,75	V22.1020.01 M	ADZU	X800	GT42	5,85	4,2	0,25	2,22	21,7	3	VD14.3 VD15.0 VD16.0
M30	2,5	5,0	V22.1630.01 M	AF00	X800	GT42	5,85	3,8	0,31	2,98	21,7	3	VD12.0
M30	3,5	6,0	V22.2140.01 M	AF72	X800	GT42	5,85	3,4	0,44	3,52	21,7	3	VD12.0
M30	3,5	6,5	V22.2445.01 M	ABAF	X800	GT42	5,85	3,2	0,44	3,84	21,7	3	VD12.0
M27	2,5	4,5	V22.2545.01 M	AEAA	X800	GT42	5,85	3,7	0,31	2,71	21,7	3	VD12.0

Bestellbeispiel // Order example: **V22.2545.01 M X800** (X800 = Schneidstoff // Grade)

Bitte beachten Sie die zusätzlichen Hinweise zu den Mehrbereichswerkzeugen im Infobereich rechts oben.
 Please read the additional notes mentioned in the information area on the top right corner of this page.

Die angegebene Gewindegrößeneignung bezieht sich auf die Startsteigung.
 The mentioned thread size „As of thread size“ is based on the starting pitch.

Mehr Infos zu den **Mehrbereichswerkzeugen** und deren **Gewindegrößeneignung** finden Sie auf Seite 649

More information about the **multi-purpose thread milling tools** and the **thread size suitability** can be found on page 649

Metrisches ISO-Gewindefräsen, Vollprofil, Außen

Fräsen von metrischen ISO-Gewinden, Vollprofil.

Thread milling, metric ISO-Thread,
 external, full profile

Thread milling of metric ISO-threads, full profile.

Schnittwerte (Start) // Cutting parameters (start)

fzm 0,04 mm	hmax 0,05 mm	Vc Seite/Page 638
-----------------------	------------------------	-----------------------------

Passende Klemmhalter auf Seite // Suitable toolholders on page
556, 557, 558, 559, 560, 561, 562, 563, 564

Bitte Hinweise im Anhang beachten // Please read add. notes
ALL (Seite/Page 645), H06 (Seite/Page 648), H07 (Seite/Page 648)

SP

HM

650

Legende
Legend

Scan
QR-Code

Oder besuchen Sie // Or Visit
www.simtek.info/cp/1175

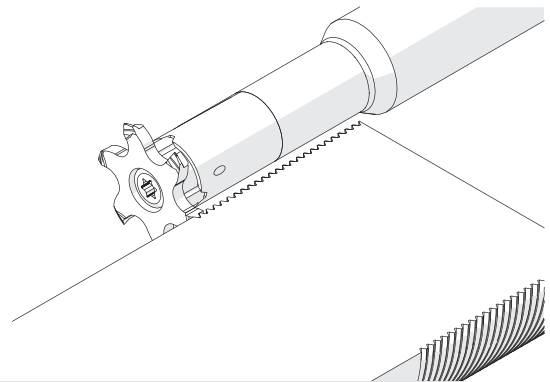
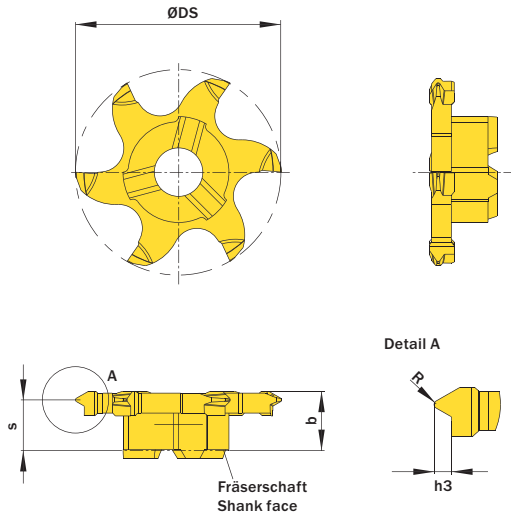


Illustration zeigt beispielhafte Anwendungsmöglichkeit mit ähnlichem Werkzeug.
 Image shows exemplary application possibility with similar tool.

h3	Steigung (von) Pitch (as of)	Artikelnummer Part number	Webcode www.simtek.com/webcode	Unsere erste Wahl Our first choice		b	R	S	ØDS	ZEFP	Connectcode www.simtek.com/code
				P	S						
0,92	1,5	V06.0815.02.22 EM	AZB9	X800	GT42	6,25	0,22	5,4	21,7	6	
1,07	1,75	V06.0917.02.22 EM	AZCA	X800	GT42	6,25	0,25	5,2	21,7	6	VD11.3 VD11.5 VD12.0
1,23	2,0	V06.1020.02.22 EM	AZCB	X800	GT42	6,25	0,29	5,1	21,7	6	VD12.7 VD13.5 VD14.0
1,84	3,0	V06.1630.02.22 EM	AZCC	X800	GT42	6,05	0,43	4,5	21,7	6	VD14.3 VD15.0 VD16.0
2,45	4,0	V06.2140.02.22 EM	AZCD	X800	GT42	6,05	0,58	4,0	21,7	6	

Bestellbeispiel // Order example: **V06.0815.02.22 EM X800** (X800 = Schneidstoff // Grade)

simmill AX
simmill PMX
simmill PX
simmill SX
simmill UX
simmill VX
simmill H2
simmill K2
simmill MX
simmill OS
Index

Whitworth-Rohrgewinde, Vollprofil

Fräsen von Whitworth-Rohrgewinden, Vollprofil mit sechs Schneiden und Werkzeug-Schneidkreis von 21,7 mm.

Whitworth Pipe Thread Milling, full profile

Whitworth pipe thread milling, full profile with six cutting edges and tool diameter of 21,7 mm.

Schnittwerte (Start) // Cutting parameters (start)

fzm 0,04 mm	hmax 0,05 mm	Vc Seite/Page 638
-----------------------	------------------------	-----------------------------

Passende Klemmhalter auf Seite // Suitable toolholders on page
556, 557, 558, 559, 560, 561, 562, 563, 564

Vergleichbare Werkzeuge auf Seite // Similar tools on page
468

Bitte Hinweise im Anhang beachten // Please read add. notes

ALL (Seite/Page 645), H03 (Seite/Page 647), H07 (Seite/Page 648)



SP Legende
HM Legend

650



Scan
 QR-Code

Oder besuchen Sie // Or Visit
www.simtek.info/cp/1061

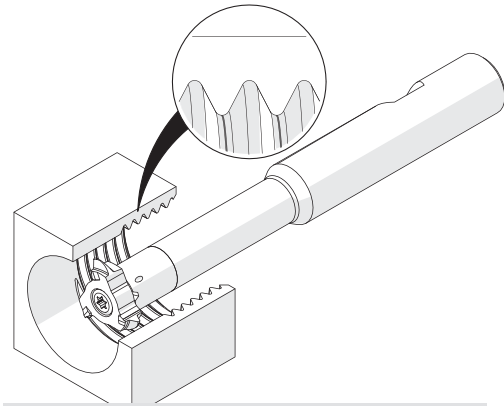
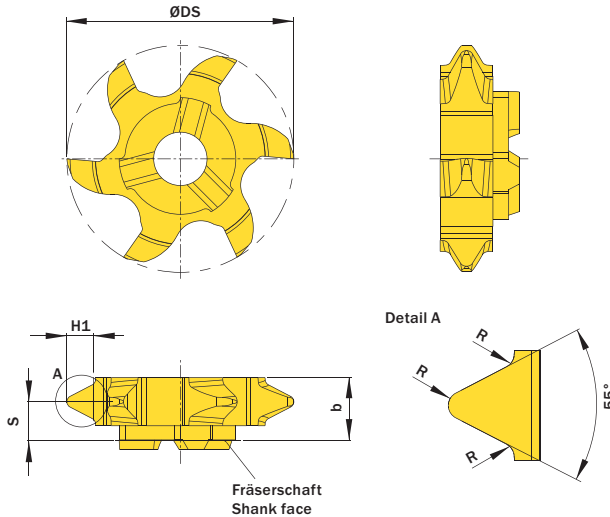


Illustration zeigt beispielhafte Anwendungsmöglichkeit mit ähnlichem Werkzeug.
 Image shows exemplary application possibility with similar tool.

Abbildung zeigt / Drawing shows: V06.5506.02.22 M

H1	Steigung (von) Pitch (as of)	Gang/Zoll Threads/inch	Artikelnummer Part number	Webcode www.simtek.com/webcode	Unsere erste Wahl Our first choice		R	b	s	ØDS	Ab Gewindegröße As of thread size	Alternativ ab Nennmesser Alternativ as of nominal diameter	ZEFP	Connectcode www.simtek.com/ccode
					P	M								
2,71	4,233	6	V06.5506.02.22 M	AVKN	X800	GT42	0,58	6,05	3,8	21,7	BSW 1 1/2	38,3	6	VD11.3 VD11.5 VD12.0
2,03	3,175	8	V06.5508.02.22 M	AVKP	X800	GT42	0,43	6,31	4,2	21,7	-	32,7	6	VD12.7 VD13.5 VD14.0
1,48	2,31	11	V06.5511.02.22 M	AVKQ	X800	GT42	0,31	6,35	4,8	21,7	G1*	30,0	6	VD14.3 VD15.0 VD16.0

Bestellbeispiel // Order example: **V06.5511.02.22 M X800** (X800 = Schneidstoff // Grade)

Whitworth-Rohrgewinde, Vollprofil

Fräsen von Whitworth-Rohrgewinden, Vollprofil mit drei Schneiden und Werkzeug-Schneidkreis von 21,7 mm.

Whitworth Pipe Thread Milling, full profile

Whitworth pipe thread milling, full profile with three cutting edges and tool diameter of 21,7 mm.

Schnittwerte (Start) // Cutting parameters (start)		
fzm 0,04 mm	hmax 0,05 mm	Vc Seite/Page 638
Passende Klemmhalter auf Seite // Suitable toolholders on page 556, 557, 558, 559, 560, 561, 562, 563, 564		
Vergleichbare Werkzeuge auf Seite // Similar tools on page 468		
Bitte Hinweise im Anhang beachten // Please read add. notes ALL (Seite/Page 645), H03 (Seite/Page 647), H07 (Seite/Page 648)		

SP Legende
HM Legend

650

Scan QR-Code Oder besuchen Sie // Or Visit
www.simtek.info/cp/414

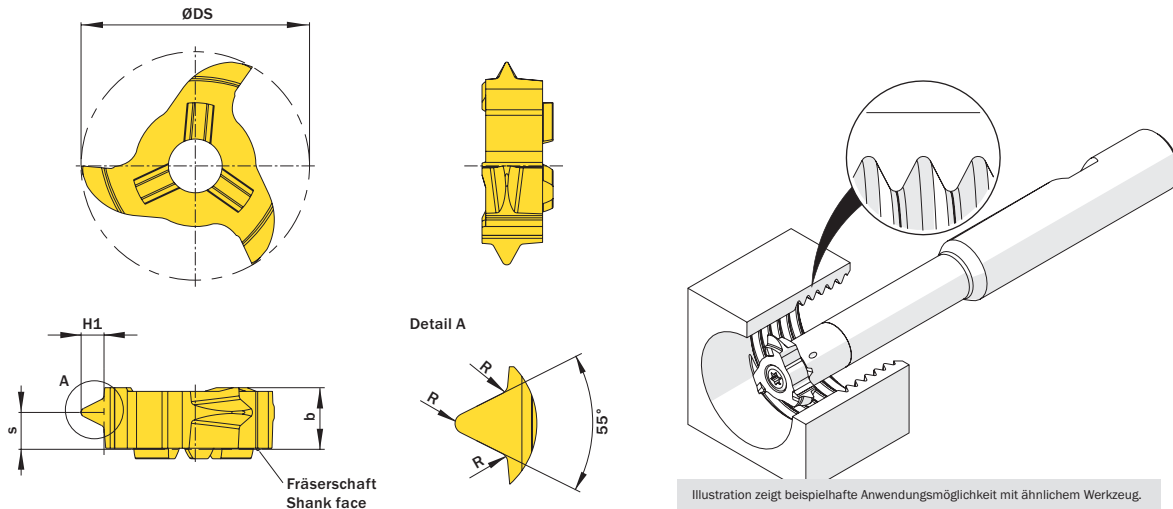


Illustration zeigt beispielhafte Anwendungsmöglichkeit mit ähnlichem Werkzeug.
 Image shows exemplary application possibility with similar tool.

Abbildung zeigt / Drawing shows: V22.5508.02 M

H1	Steigung (von) / Pitch (as of)		Gang/Zoll Threads/Inch	Artikelnummer Part number	Webcode www.simtek.com/webcode	Unsere erste Wahl Our first choice		R	b	s	ØDS	Ab Gewindegröße As of thread size	Alternativ ab Nenndurchmesser Alternativ as of nominal diameter	ZEFP	Connectcode www.simtek.com/ccode
	mm	mm				P	S								
2,71	4,233	6	V22.5506.02 M	AMJF	X800	GT42	0,58	5,85	3,1	21,7	BSW 1 1/2"	38,3	3	VD11.3 VD11.5 VD12.0	
2,03	3,175	8	V22.5508.02 M	ANNK	X800	GT42	0,43	5,85	3,5	21,7	-	32,7	3	VD12.7 VD13.5 VD14.0	
1,48	2,309	11	V22.5511.02 M	ADVP	X800	GT42	0,31	5,85	4,0	21,7	G 1"	30,0	3	VD14.3 VD15.0 VD16.0	

Bestellbeispiel // Order example: **V22.5511.02 M X800** (X800 = Schneidstoff // Grade)

simmill AX

simmill PMX

simmill PX

simmill SX

simmill UX

simmill VX

simmill H2

simmill K2

simmill MX

simmill OS

Index

Fräsen von Fasen

Fasenfräsen beidseitig. Geeignet ab Bohrungsdurchmesser 22,0 mm.

Chamfering


Chamfering on both sides.
 For use in bores as of minimum bore diameter 22,0 mm.

Schnittwerte (Start) // Cutting parameters (start)		
fzm 0,04 mm	hmax 0,05 mm	Vc Seite/Page 638

Passende Klemmhalter auf Seite // Suitable toolholders on page
556, 557, 558, 559, 560, 561, 562, 563, 564

Vergleichbare Werkzeuge auf Seite // Similar tools on page
469

Bitte Hinweise im Anhang beachten // Please read add. notes
ALL (Seite/Page 645), H02 (Seite/Page 646), H07 (Seite/Page 648)



SP	Legende	650
HM	Legend	

Scan QR-Code Oder besuchen Sie // Or Visit www.simtek.info/cp/408

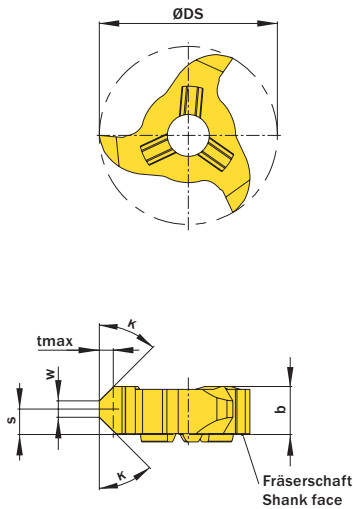


Abbildung zeigt / Drawing shows: V22.4545.58 F

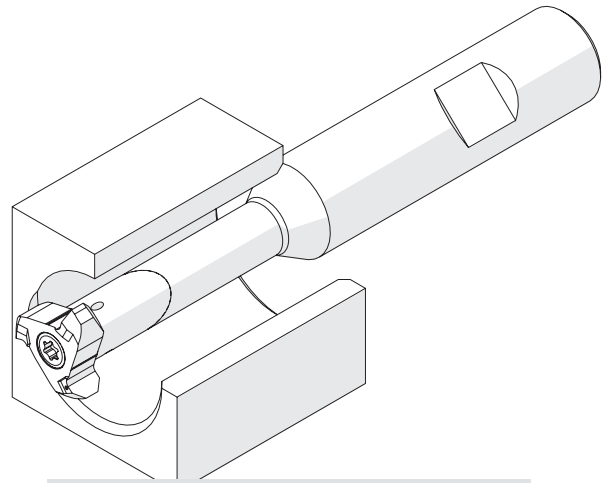


Illustration zeigt beispielhafte Anwendungsmöglichkeit mit ähnlichem Werkzeug.
 Image shows exemplary application possibility with similar tool.

K	W	ØDmin (Min. Bohrung) ØDmin (min. bore)	Artikelnummer Part number	Webcode www.simtek.com/webcode	Unsere erste Wahl Our first choice		tmax	b	S	ØDS	ZEFP	Connectcode www.simtek.com/ccode					
					P	M						K	N	S	VD11.3	VD11.5	VD12.0
45°	2,0	22,0	V22.4545.58 F	ADU1	X800	G142	1,7	5,85	3,0	21,7	3						
45°	3,0	22,0	V22.4545.94 F	AH71	X800	G142	3,0	9,4	4,8	21,7	3						

Bestellbeispiel // Order example: **V22.4545.94 F X800** (X800 = Schneidstoff // Grade)

Bei Verwendung des Schneidwerkzeugs „V22.4545.94 F“ wird die längere Schraube „V M5x16 T20T“ benötigt.
 For using the cutting tool „V22.4545.94 F“, the longer screw „V M5x16 T20T“ is needed.

Fräsen von Fasen

Fasenfräsen beidseitig. Geeignet ab Bohrungsdurchmesser 22,0 mm.

Chamfering

Chamfering on both sides.
 For use in bores as of minimum bore diameter 22,0 mm.

Schnittwerte (Start) // Cutting parameters (start)

f _{zm} 0,04 mm	h _{max} 0,05 mm	V _c Seite/Page 638
-----------------------------------	------------------------------------	---

Passende Klemmhalter auf Seite // Suitable toolholders on page
556, 557, 558, 559, 560, 561, 562, 563, 564

Vergleichbare Werkzeuge auf Seite // Similar tools on page
469

Bitte Hinweise im Anhang beachten // Please read add. notes
ALL (Seite/Page 645), H05 (Seite/Page 648), H07 (Seite/Page 648)



SP Legende
HM Legend
650

Scan QR-Code Oder besuchen Sie // Or Visit
www.simtek.info/cp/410

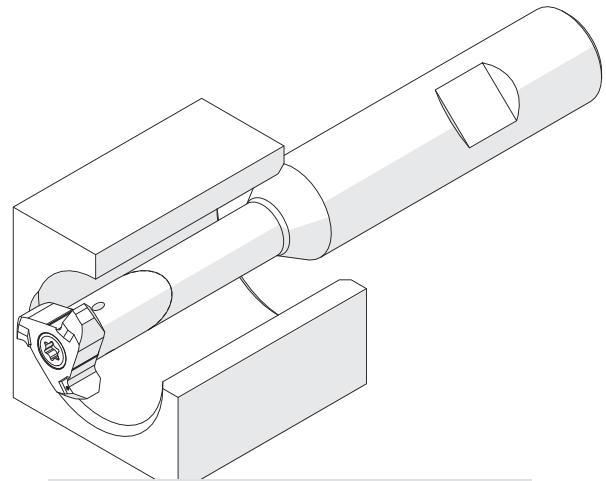
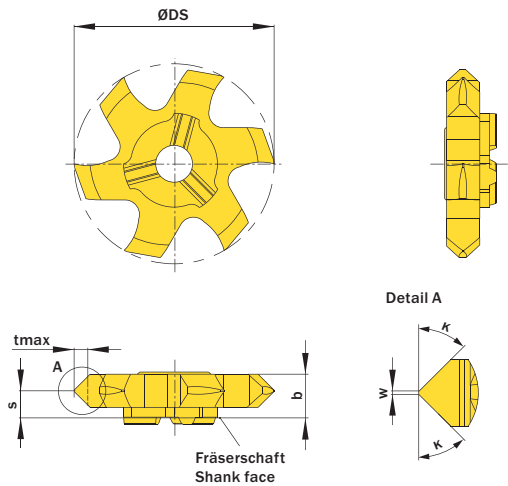


Illustration zeigt beispielhafte Anwendungsmöglichkeit mit ähnlichem Werkzeug.
 Image shows exemplary application possibility with similar tool.

Abbildung zeigt / Drawing shows: V06.4545.020.28 F

K	W mm	ØDmin (Min. Bohrung) ØDmin (min. bore) mm	Artikelnummer Part number	Webcode www.simtek.com/webcode	Unsere erste Wahl Our first choice		t _{max} mm	b mm	S mm	ØDS mm	ZEFP	Connectcode www.simtek.com/ccode
					P	S						
45°	0,2	22,0	V06.4545.020.22 F	AE4P	X800	G142	2,0	6,05	3,8	21,7	6	VD11.3 VD11.5 VD12.0 VD12.7 VD13.5 VD14.0 VD14.3 VD15.0 VD16.0
45°	0,2	28,0	V06.4545.020.28 F	AT86	X800	G142	2,0	6,5	3,8	27,7	6	VD11.3 VD11.5 VD12.0 VD12.7 VD13.5 VD14.0 VD14.3 VD15.0 VD16.0

Bestellbeispiel // Order example: **V06.4545.020.22 F X800** (X800 = Schneidstoff // Grade)

simmill AX
 simmill PMX
 simmill PX
 simmill SX
 simmill UX
simmill VX
 simmill H2
 simmill K2
 simmill MX
 simmill OS
 Index

Fräsen von Kantenverrundungen (Entgraten)

Viertelkreisfräser konkav zur einfachen Verrundung von Kanten. Geeignet ab Bohrungsdurchmesser 22,0 mm bei der Verrundung von Bohrungen.

Corner Rounding (Deburring)

Quadrant milling insert for corner rounding. For use in bores as of minimum bore diameter 22,0 mm when rounding bore corners.

Schnittwerte (Start) // Cutting parameters (start)

fzm 0,04 mm	hmax 0,05 mm	Vc Seite/Page 638
-----------------------	------------------------	-----------------------------

Passende Klemmhalter auf Seite // Suitable toolholders on page

556, 557, 558, 559, 560, 561, 562, 563, 564

Bitte Hinweise im Anhang beachten // Please read add. notes

ALL (Seite/Page 645), H07 (Seite/Page 648)



SP Legende
HM Legend

650



Scan
 QR-Code

Oder besuchen Sie // Or Visit
www.simtek.info/cp/411

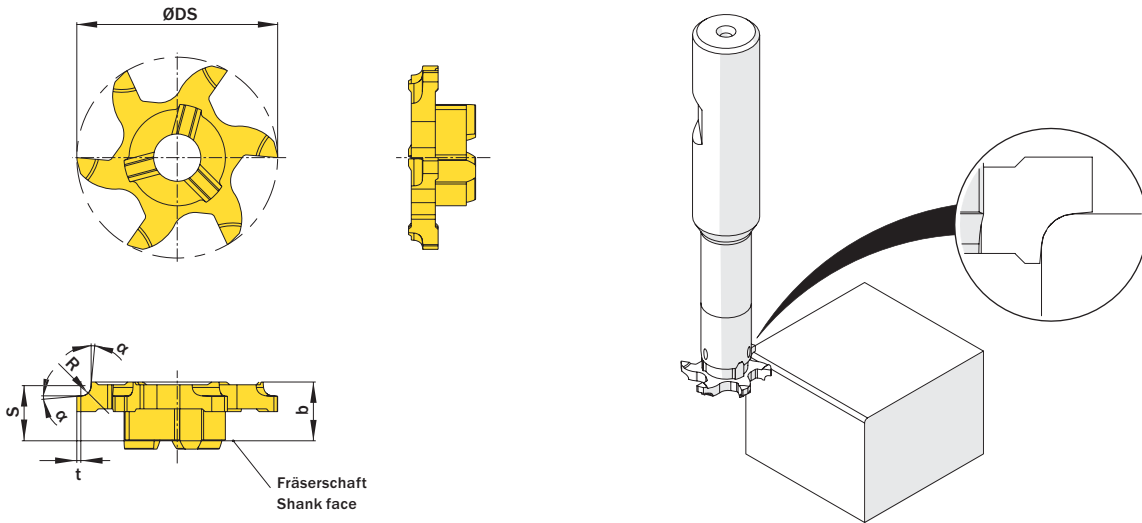


Abbildung zeigt / Drawing shows: V06.R100.22 F

R	ØDmin (Min. Bohrung) ØDmin (min. bore)	Artikelnummer Part number	Webcode www.simtek.com/webcode	Unsere erste Wahl Our first choice	b	S	t	α	ØDS	ZEFP	Connectcode www.simtek.com/ccode
mm	mm			P M K N S	mm	mm	mm		mm		
0,2	22,0	V06.R020.22 F	AA2K	X800 GT42	6,35	5,8	0,5	5°	21,7	6	VD12.0
0,5	22,0	V06.R050.22 F	AHJG	X800 GT42	6,35	5,8	0,5	5°	21,7	6	VD12.0
0,6	22,0	V06.R060.22 F	AKDK	X800 GT42	6,35	5,8	0,5	5°	21,7	6	VD12.0
0,8	22,0	V06.R080.22 F	AMYF	X800 GT42	6,35	5,8	0,5	5°	21,7	6	VD12.0
1,0	22,0	V06.R100.22 F	AMU5	X800 GT42	6,35	5,8	0,5	5°	21,7	6	VD12.0
1,25	22,0	V06.R125.22 F	AKP3	X800 GT42	6,35	5,8	0,5	5°	21,7	6	VD12.0
1,5	22,0	V06.R150.22 F	AKVS	X800 GT42	6,05	5,6	0,5	5°	21,7	6	VD12.0
2,0	22,0	V06.R200.22 F	AHG3	X800 GT42	6,05	5,6	0,5	5°	21,7	6	VD12.0
2,25	22,0	V06.R225.22 F	ABG4	X800 GT42	6,05	5,6	0,5	5°	21,7	6	VD12.0
2,5	22,0	V06.R250.22 F	ABDT	X800 GT42	6,05	5,6	0,5	5°	21,7	6	VD12.0
3,0	22,0	V06.R300.22 F	AB8E	X800 GT42	6,05	5,6	0,5	5°	21,7	6	VD12.0

Bestellbeispiel // Order example: **V06.R300.22 F X800** (X800 = Schneidstoff // Grade)

Stirn- und Planfräsen

Schneidkreisdurchmesser ab 19,7 mm mit 6 Schneiden.

Face Milling

Tool diameter of 19,7 mm with 6 cutting edges.

Schnittwerte (Start) // Cutting parameters (start)

fzm 0,04 mm	hmax 0,05 mm	Vc Seite/Page 638
-----------------------	------------------------	-----------------------------

Passende Klemmhalter auf Seite // Suitable toolholders on page
556, 557, 558, 559, 560, 561, 562, 563, 564

Vergleichbare Werkzeuge auf Seite // Similar tools on page
471

Bitte Hinweise im Anhang beachten // Please read add. notes
ALL (Seite/Page 645), H07 (Seite/Page 648)



SP Legende
HM Legende **650**

Scan QR-Code Oder besuchen Sie // Or Visit
www.simtek.info/cp/412

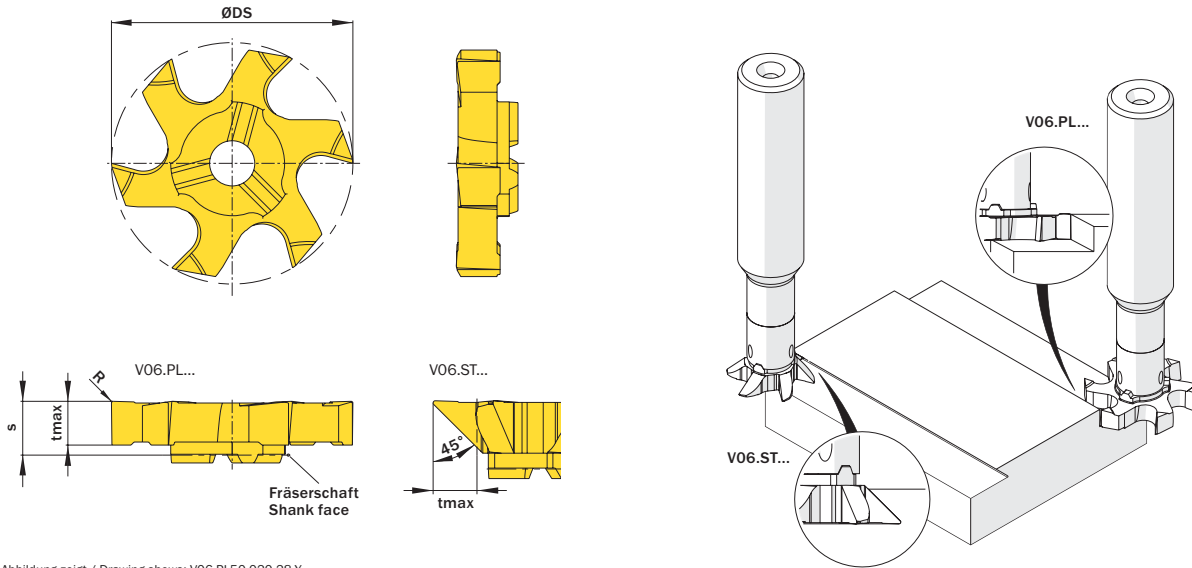


Abbildung zeigt / Drawing shows: V06.PL50.020.28 Y

tmax	R	ØDmin (Min. Bohrung) ØDmin (min. bore)	Artikelnummer Part number	Webcode www.simtek.com/webcode	Unsere erste Wahl Our first choice	S	ØDS	ZEFF // ZEFP	Connectcode www.simtek.com/code
mm	mm	mm			P M K N S	mm	mm		
5,0	0,2	20,0	V06.PL50.020.20 Y	AVJØ	X800 GT42	6,2	19,7	6	VD11.3 VD11.5 VD12.0
5,0	0,2	28,0	V06.PL50.020.28 Y	AGFH	X800 GT42	6,2	27,7	6	VD12.7 VD13.5 VD14.0
4,0	0,2	22,0	V06.ST40.020.22 Y	AØ3F	X800 GT42	6,2	21,7	6	VD14.3 VD15.0 VD16.0

Bestellbeispiel // Order example: **V06.PL50.020.28 Y X800** (X800 = Schneidstoff // Grade)

simmill AX

simmill PMX

simmill PX

simmill SX

simmill UX

simmill VX

simmill H2

simmill K2

simmill MX

simmill OS

Index

Allgemeines Nutfräsen

Nutfräsen gerader Nutformen.
Geeignet ab Bohrungsdurchmesser 25,0 mm.

General Groove Milling

General groove milling.
For use in bores as of minimum bore diameter 25,0 mm.

Schnittwerte (Start) // Cutting parameters (start)		
fzm 0,04 mm	hmax 0,05 mm	Vc Seite/Page 638

Passende Klemmhalter auf Seite // Suitable toolholders on page
556, 557, 558, 559, 560, 561, 563

Vergleichbare Werkzeuge auf Seite // Similar tools on page
461

Bitte Hinweise im Anhang beachten // Please read add. notes
ALL (Seite/Page 645), H01 (Seite/Page 646), H07 (Seite/Page 648)

SP

Legende

HM

Legend

650

Scan QR-Code

Oder besuchen Sie // Or Visit
www.simtek.info/cp/375

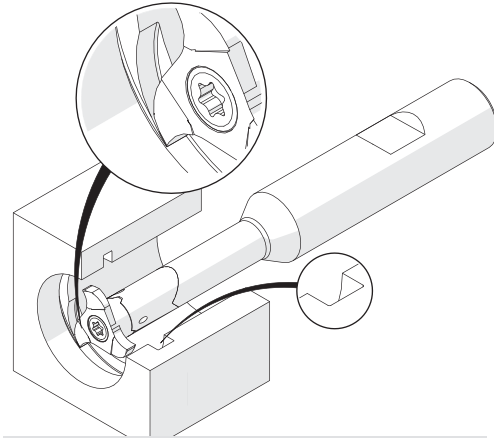
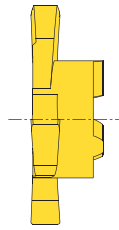
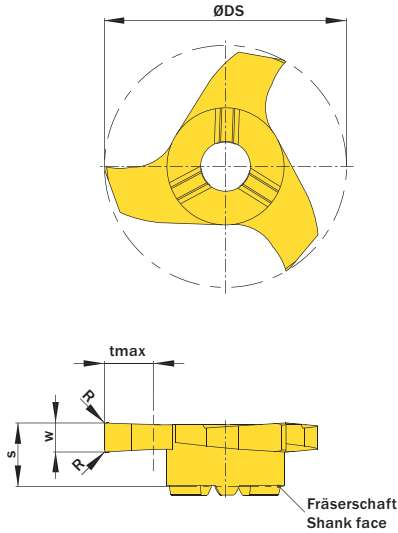


Illustration zeigt beispielhafte Anwendungsmöglichkeit mit ähnlichem Werkzeug.
Image shows exemplary application possibility with similar tool.

Abbildung zeigt / Drawing shows: V25.0300.02 G

w ^{+0,02}	R	ØDmin (Min. Bohrung) ØDmin (min. bore)	Artikelnummer Part number	Webcode www.simtek.com/webcode	Unsere erste Wahl Our first choice	tmax	S	ØDS	ZEFP	Connectcode www.simtek.com/code
mm	mm	mm			P M K N S	mm	mm	mm		
2,0	0,2	25,0	V25.0200.02 G	AHS7	X800 GT42	5,0	6,6	24,8	3	VD14.0 VD14.3
2,388	0,2	25,0	V25.0239.02 G	APTW	X800 GT42	5,0	6,6	24,8	3	VD14.0 VD14.3 Inch
2,5	0,2	25,0	V25.0250.02 G	ACG1	X800 GT42	5,0	6,6	24,8	3	VD14.0 VD14.3
3,0	0,2	25,0	V25.0300.02 G	AFPB	X800 GT42	5,0	6,6	24,8	3	VD14.0 VD14.3
3,175	0,2	25,0	V25.0318.02 G	AAZ4	X800 GT42	5,0	6,6	24,8	3	VD14.0 VD14.3 Inch
3,5	0,2	25,0	V25.0350.02 G	AKG8	X800 GT42	5,0	6,6	24,8	3	VD14.0 VD14.3
4,0	0,2	25,0	V25.0400.02 G	AA9X	X800 GT42	5,0	6,6	24,8	3	VD14.0 VD14.3
4,75	0,2	25,0	V25.0475.02 G	AMMV	X800 GT42	5,0	6,6	24,8	3	VD14.0 VD14.3
5,0	0,2	25,0	V25.0500.02 G	AZCF	X800 GT42	5,0	6,6	24,8	3	VD14.0 VD14.3

Bestellbeispiel // Order example: **V25.0200.02 G X800** (X800 = Schneidstoff // Grade)



V25. w, 1/100 mm, 4 Stellen/Digits . R, 1/100 mm, 3 Stellen/Digits Toleranz // Tolerance
Beispielartikelnummer // Example Part number: **V25.0179.030 XG**



Allgemeines Nutfräsen

Nutfräsen gerader Nutformen.
 Geeignet ab Bohrungsdurchmesser 28,0 mm.

General Groove Milling

General groove milling.
 For use in bores as of minimum bore diameter 28,0 mm.

Schnittwerte (Start) // Cutting parameters (start)		
fzm 0,04 mm	hmax 0,05 mm	Vc Seite/Page 638
Passende Klemmhalter auf Seite // Suitable toolholders on page 556, 557, 558, 559, 560, 561, 563		
Vergleichbare Werkzeuge auf Seite // Similar tools on page 461		
Bitte Hinweise im Anhang beachten // Please read add. notes ALL (Seite/Page 645), H01 (Seite/Page 646), H02 (Seite/Page 646), H07 (Seite/Page 648)		


SP Legende
HM Legend **650**
 Scan
 Oder besuchen Sie // Or Visit www.simtek.info/cp/376

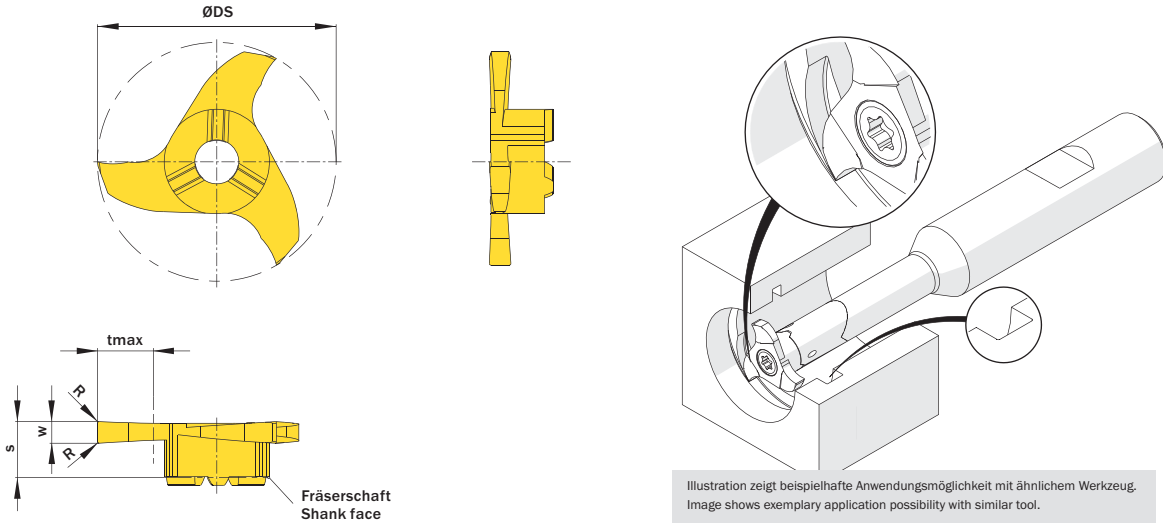


Illustration zeigt beispielhafte Anwendungsmöglichkeit mit ähnlichem Werkzeug.
 Image shows exemplary application possibility with similar tool.

Abbildung zeigt / Drawing shows: V28.0250.02 G

w ^{+0,02}	R	ØDmin (Min. Bohrung) ØDmin (min. bore)	Artikelnummer Part number	Webcode www.simtek.com/webcode	Unsere erste Wahl Our first choice	tmax	S	ØDS	ZEFP	Connectcode www.simtek.com/code
mm	mm	mm			P M K N S	mm	mm	mm		
1,5	0,2	28,0	V28.0150.02 G	AN4A	X800 GT42	6,5	6,6	27,7	3	VD14.0 VD14.3
2,0	0,2	28,0	V28.0200.02 G	AG3V	X800 GT42	6,5	6,6	27,7	3	VD14.0 VD14.3
2,5	0,2	28,0	V28.0250.02 G	AECZ	X800 GT42	6,5	6,6	27,7	3	VD14.0 VD14.3
3,0	0,2	28,0	V28.0300.02 G	ADQJ	X800 GT42	6,5	6,6	27,7	3	VD14.0 VD14.3
3,5	0,2	28,0	V28.0350.02 G	AP0W	X800 GT42	6,5	6,6	27,7	3	VD14.0 VD14.3
4,0	0,2	28,0	V28.0400.02 G	AGNX	X800 GT42	6,5	6,6	27,7	3	VD14.0 VD14.3
5,0	0,2	28,0	V28.0500.02 G	APST	X800 GT42	6,5	6,6	27,7	3	VD14.0 VD14.3
6,0	0,2	28,0	V28.0600.02 G	APNV	X800 GT42	6,5	6,6	27,7	3	VD14.0 VD14.3
6,35	0,2	28,0	V28.0635.02 G	A20E	X800 GT42	6,5	6,6	27,7	3	VD14.0 VD14.3
10,0	0,2	28,0	V28.1000.02 G	AXXP	X800 GT42	6,5	10,0	27,7	3	VD14.0 VD14.3

Bestellbeispiel // Order example: **V28.0400.02 G X800** (X800 = Schneidstoff // Grade)

Bei Verwendung des Schneidwerkzeugs „V28.1000.02 G“ wird die längere Schraube „V M5x16 T20T“ benötigt. Aufgrund der hohen Schneidbreite bei manchen Materialien nur bedingt einsetzbar.

For using the cutting tool „V28.1000.02 G“, the longer screw „V M5x16 T20T“ is needed. Limited suitability for the use in some materials due to the high cutting width.



V28. w, 1/100 mm, 4 Stellen/Digits . R, 1/100 mm, 3 Stellen/Digits Toleranz // Tolerance
 Beispielpartikelnummer // Example Part number: **V28.0179.030 XG**

simmill AX
simmill PMX
simmill PX
simmill SX
simmill UX
simmill VX
simmill H2
simmill K2
simmill MX
simmill OS
Index

Allgemeines Nutfräsen

Nutfräsen gerader Nutformen.
 Geeignet ab Bohrungsdurchmesser 28,3 mm.

General Groove Milling

General groove milling.
 For use in bores as of minimum bore diameter 28,3 mm.

Schnittwerte (Start) // Cutting parameters (start)		
fzm 0,01 mm	hmax 0,02 mm	Vc Seite/Page 638
Passende Klemmhalter auf Seite // Suitable toolholders on page		
556, 559, 560, 561		
Vergleichbare Werkzeuge auf Seite // Similar tools on page		
461		
Bitte Hinweise im Anhang beachten // Please read add. notes		
ALL (Seite/Page 645), H01 (Seite/Page 646), H07 (Seite/Page 648)		

SP

Legende

HM

Legend

650

Scan QR-Code

Oder besuchen Sie // Or Visit

www.simtek.info/cp/377

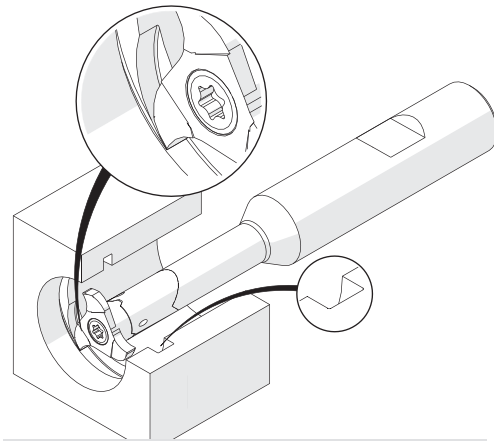
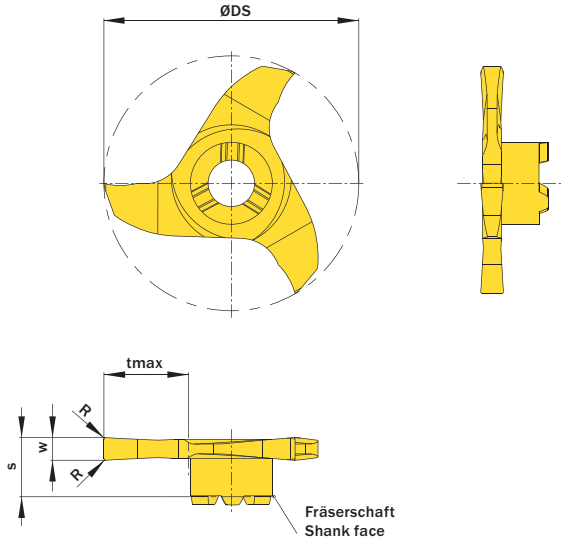


Illustration zeigt beispielhafte Anwendungsmöglichkeit mit ähnlichem Werkzeug.
 Image shows exemplary application possibility with similar tool.

Abbildung zeigt / Drawing shows: V28.0250.02.09 G

w ^{-0,02}	Nuttenbreite Nominal width of groove	R	ØDmin (Min. Bohrung) ØDmin (min. bore)	Artikelnummer Part number	Webcode www.simtek.com/webcode	Unsere erste Wahl Our first choice	tmax	S	ØDS	ZEFP	Connectcode www.simtek.com/ccode
mm	mm	mm	mm			P M K N S	mm	mm	mm		
1,5	-	0,2	28,3	V28.0150.02.09 G	AC15	X800 GT42	9,3	6,5	28,0	3	VD09.0
1,6	-	0,2	28,3	V28.0160.02.09 G	A5PD	X800 GT42	9,3	6,5	28,0	3	VD09.0 new
2,0	-	0,2	28,3	V28.0200.02.09 G	AM94	X800 GT42	9,3	6,5	28,0	3	VD09.0
2,5	-	0,2	28,3	V28.0250.02.09 G	AD74	X800 GT42	9,3	6,5	28,0	3	VD09.0

Bestellbeispiel // Order example: **V28.0200.02.09 G X800** (X800 = Schneidstoff // Grade)

Allgemeines Nutfräsen

Nutfräsen gerader Nutformen.
 Geeignet ab Bohrungsdurchmesser 28,3 mm.

General Groove Milling

General groove milling.
 For use in bores as of minimum bore diameter 28,3 mm.

Schnittwerte (Start) // Cutting parameters (start)		
f _{zm} 0,04 mm	h _{max} 0,05 mm	V _c Seite/Page 638
Passende Klemmhalter auf Seite // Suitable toolholders on page 556, 559, 560, 561		
Vergleichbare Werkzeuge auf Seite // Similar tools on page 461		
Bitte Hinweise im Anhang beachten // Please read add. notes ALL (Seite/Page 645), H01 (Seite/Page 646), H05 (Seite/Page 648), H07 (Seite/Page 648)		

SP Legende
HM Legend

650

Scan QR-Code Oder besuchen Sie // Or Visit
www.simtek.info/cp/1003

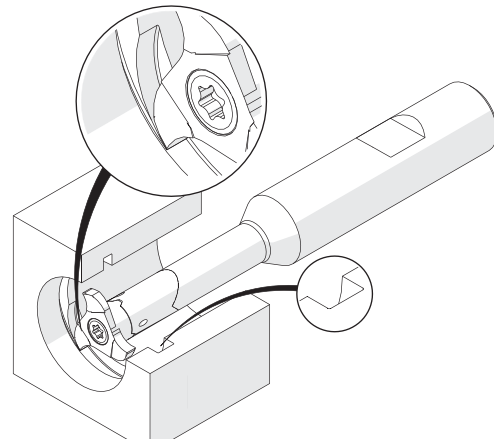
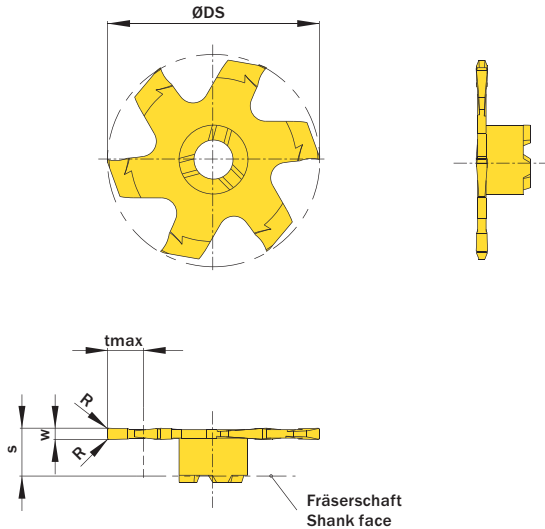


Illustration zeigt beispielhafte Anwendungsmöglichkeit mit ähnlichem Werkzeug.
 Image shows exemplary application possibility with similar tool.

Abbildung zeigt / Drawing shows: V06.0150.020.28.09 G

w ^{+0,02} mm	Nuttenbreite Nominal width of groove mm	R mm	ØDmin (Min. Bohrung) ØDmin (min. bore) mm	Artikelnummer Part number	Webcode www.simtek.com/webcode	Unsere erste Wahl Our first choice		t _{max} mm	s mm	ØDS mm	ZEFP	Connectcode www.simtek.com/ccode	
						P M K N S							
1,2	-	0,2	28,3	V06.0120.020.28.09 G	A3DT	X800	G142	9,3	6,2	28,0	6	VD09.0	new
1,5	-	0,2	28,3	V06.0150.020.28.09 G	AV93	X800	G142	9,3	6,2	28,0	6	VD09.0	upd
2,0	-	0,2	28,3	V06.0200.020.28.09 G	A6F3	X800	G142	9,3	6,2	28,0	6	VD09.0	new
2,4	-	0,2	28,3	V06.0240.020.28.09 G	AXXN	X800	G142	9,3	6,2	28,0	6	VD09.0	upd

Bestellbeispiel // Order example: **V06.0150.020.28.09 G X800** (X800 = Schneidstoff // Grade)

simmill AX
simmill PMX
simmill PX
simmill SX
simmill UX
simmill VX
simmill H2
simmill K2
simmill MX
simmill OS
Index

Allgemeines Nutfräsen

Nutfräsen gerader Nutformen.
 Geeignet ab Bohrungsdurchmesser 28,0 mm.

General Groove Milling

General groove milling.
 For use in bores as of minimum bore diameter 28,0 mm.

Schnittwerte (Start) // Cutting parameters (start)

f _{zm} 0,04 mm	h _{max} 0,05 mm	V _c Seite/Page 638
-----------------------------------	------------------------------------	---

Passende Klemmhalter auf Seite // Suitable toolholders on page
556, 557, 558, 559, 560, 561, 563

Vergleichbare Werkzeuge auf Seite // Similar tools on page
461

Bitte Hinweise im Anhang beachten // Please read add. notes

ALL (Seite/Page 645), H01 (Seite/Page 646), H05 (Seite/Page 648), H07 (Seite/Page 648)



SP Legende
HM Legend
650

Scan QR-Code Oder besuchen Sie // Or Visit
www.simtek.info/cp/381

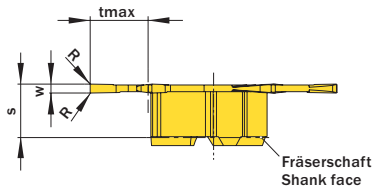
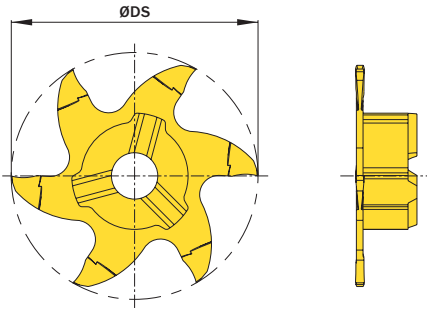


Abbildung zeigt / Drawing shows: V06.0100.010.28 G

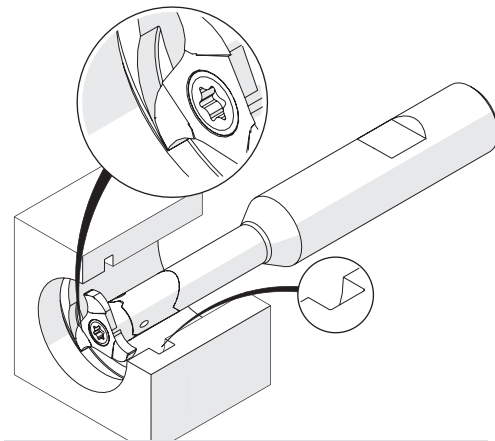


Illustration zeigt beispielhafte Anwendungsmöglichkeit mit ähnlichem Werkzeug.
 Image shows exemplary application possibility with similar tool.

w ^{+0,02} mm	Nuttenbreite Nominal width of groove mm	R mm	ØDmin (Min. Bohrung) ØDmin (min. bore) mm	Artikelnummer Part number	Webcode www.simtek.com/webcode	Unsere erste Wahl Our first choice		tmax mm	S mm	ØDS mm	ZEFP	Connectcode www.simtek.com/ccode
						P M K N S	GT42					
1,0	-	0,1	28,0	V06.0100.010.28 G	AASZ	X800	GT42	6,5	6,0	27,7	6	VD14.0 VD14.3
1,2	-	0,1	28,0	V06.0120.010.28 G	AKEZ	X800	GT42	6,5	6,1	27,7	6	VD14.0 VD14.3
1,5	-	0,1	28,0	V06.0150.010.28 G	AD7U	X800	GT42	6,5	6,4	27,7	6	VD14.0 VD14.3
2,0	-	0,2	28,0	V06.0200.020.28 G	AN7K	X800	GT42	6,5	6,4	27,7	6	VD14.0 VD14.3
2,5	-	0,2	28,0	V06.0250.020.28 G	AH3Y	X800	GT42	6,5	6,4	27,7	6	VD14.0 VD14.3
3,0	-	0,2	28,0	V06.0300.020.28 G	APW3	X800	GT42	6,5	6,4	27,7	6	VD14.0 VD14.3
4,0	-	0,2	28,0	V06.0400.020.28 G	AP00	X800	GT42	6,5	6,4	27,7	6	VD14.0 VD14.3
5,0	-	0,2	28,0	V06.0500.020.28 G	AP9Z	X800	GT42	6,5	6,4	27,7	6	VD14.0 VD14.3
6,0	-	0,2	28,0	V06.0600.020.28 G	AP90	X800	GT42	6,5	6,4	27,7	6	VD14.0 VD14.3

Bestellbeispiel // Order example: **V06.0400.020.28 G X800** (X800 = Schneidstoff // Grade)



V06. **w, 1/100 mm, 4 Stellen/Digits** . **R, 1/100 mm, 3 Stellen/Digits** .28 **Toleranz // Tolerance**
 Beispielartikelnummer // Example Part number: **V06.0179.030.28 XG**

Fräsen von Sicherungsringnuten, innen

Fräsen von Sicherungsringnuten in Bohrungen ab Bohrungsdurchmesser 28,0 mm. Geeignet für alle Materialien.

Circlip Ring Groove Milling, internal

Circlip Ring Groove Milling in bores as of bore diameter 28,0 mm. For use in all materials.

Schnittwerte (Start) // Cutting parameters (start)

fzm 0,04 mm	hmax 0,05 mm	Vc Seite/Page 638
-----------------------	------------------------	-----------------------------

Passende Klemmhalter auf Seite // Suitable toolholders on page
556, 557, 558, 559, 560, 561, 563

Bitte Hinweise im Anhang beachten // Please read add. notes

ALL (Seite/Page 645), H01 (Seite/Page 646), H05 (Seite/Page 648), H07 (Seite/Page 648)



SP Legende
HM Legend

650



Scan QR-Code

Oder besuchen Sie // Or Visit
www.simtek.info/cp/1254

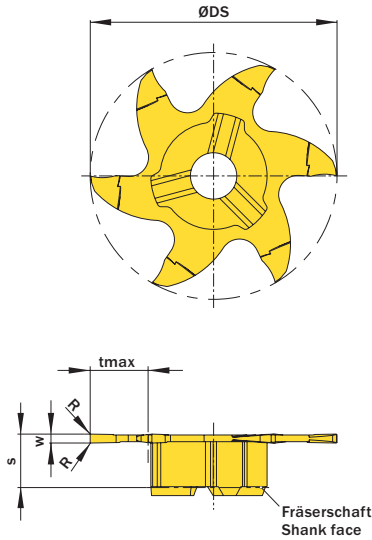


Abbildung zeigt / Drawing shows: V06.0100.010.28 G

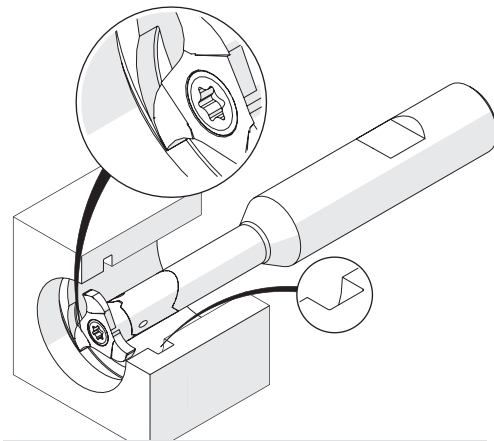


Illustration zeigt beispielhafte Anwendungsmöglichkeit mit ähnlichem Werkzeug.
 Image shows exemplary application possibility with similar tool.

w ^{-0,02} mm	Nuttenbreite Nominal width of groove mm	R mm	ØDmin (Min. Bohrung) ØDmin (min. bore) mm	Artikelnummer Part number	Webcode www.simtek.com/webcode	Unsere erste Wahl Our first choice P M K N S	tmax mm	S mm	ØDS mm	ZAFP	Connectcode www.simtek.com/ccode	upd
▼ w = 1,99 mm												
1,99	1,85	0,15	28,0	V06.0185.020.28 G	AZEP	X800 GT42	6,5	6,4	27,7	6	VD14.0 VD14.3	upd
▼ w = 2,29 mm												
2,29	2,15	0,15	28,0	V06.0215.020.28 G	APE9	X800 GT42	6,5	6,2	27,7	6	VD14.0 VD14.3	upd

Bestellbeispiel // Order example: **V06.0215.020.28 G X800** (X800 = Schneidstoff // Grade)

simmill AX
 simmill PMX
 simmill PX
 simmill SX
 simmill UX
 simmill VX
 simmill H2
 simmill K2
 simmill MX
 simmill OS
 Index

Allgemeines Nutfräsen in Leichtmetall

Nutfräsen gerader Nutformen in Bohrungen ab Bohrungsdurchmesser 28,0 mm. Durch hochpositive Schneidengeometrie besonders geeignet für Leichtmetalle.

General Groove Milling in light alloys

General groove milling in bores as of bore diameter 28,0 mm. High positive rake angle for use in light alloys.

Schnittwerte (Start) // Cutting parameters (start)

f _{zm} 0,04 mm	h _{max} 0,05 mm	V _c Seite/Page 638
-----------------------------------	------------------------------------	---

Passende Klemmhalter auf Seite // Suitable toolholders on page
556, 557, 558, 559, 560, 561, 563

Vergleichbare Werkzeuge auf Seite // Similar tools on page
462

Bitte Hinweise im Anhang beachten // Please read add. notes

ALL (Seite/Page 645), H01 (Seite/Page 646), H07 (Seite/Page 648)



Legende
 Legend **650**

Scan
 QR-Code

Oder besuchen Sie // Or Visit
www.simtek.info/cp/378

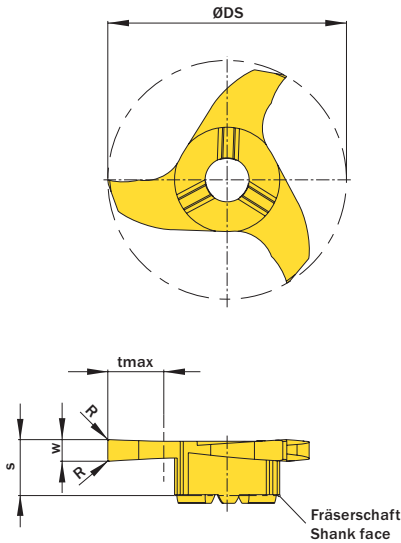


Abbildung zeigt / Drawing shows: V28.0250.42 C

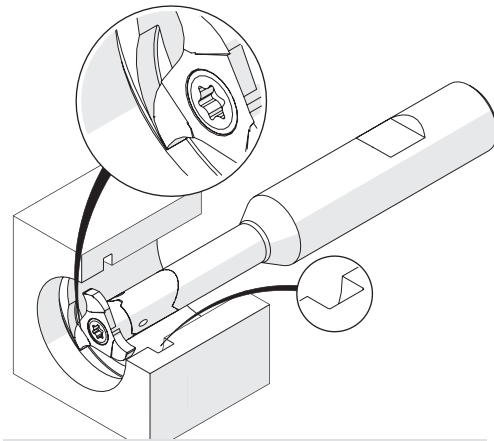


Illustration zeigt beispielhafte Anwendungsmöglichkeit mit ähnlichem Werkzeug.
 Image shows exemplary application possibility with similar tool.

w ^{+0,02}	Nuttenbreite Nominal width of groove	R	ØDmin (Min.-Bohrung) ØDmin (min. bore)	Artikelnummer Part number	Webcode www.simtek.com/webcode	Unsere erste Wahl Our first choice		t _{max}	S	ØDS	ZEFP	Connectcode www.simtek.com/ccode
						P M K N S	HT42					
2,0	-	0,2	28,0	V28.0200.42 C	AFTT	X808	HT42	6,5	6,5	27,7	3	VD14.0 VD14.3
2,5	-	0,2	28,0	V28.0250.42 C	ANF5	X808	HT42	6,5	6,5	27,7	3	VD14.0 VD14.3
3,0	-	0,2	28,0	V28.0300.42 C	ADPF	X808	HT42	6,5	6,5	27,7	3	VD14.0 VD14.3
3,5	-	0,2	28,0	V28.0350.42 C	APHB	X808	HT42	6,5	6,5	27,7	3	VD14.0 VD14.3
4,0	-	0,2	28,0	V28.0400.42 C	AGPH	X808	HT42	6,5	6,5	27,7	3	VD14.0 VD14.3

Bestellbeispiel // Order example: **V28.0400.42 C X808** (X808 = Schneidstoff // Grade)



V28. **w, 1/100 mm, 4 Stellen/Digits** . **R, 1/100 mm, 3 Stellen/Digits** **Toleranz // Tolerance C**
 Beispielartikelnummer // Example Part number: **V28.0179.030 XG C**


Metrisches ISO-Gewindfräsen, Teilprofil


Ausgelegt als Mehrbereichswerkzeuge. Die angegebene „Steigung (von)“ ist normgerecht. Die „Steigung (bis)“ kann ebenfalls realisiert werden. Vgl. Hinweistexte.

Thread milling, metric ISO-Thread, partial profile

Multi-purpose milling inserts. The given „Pitch (as of)“ is conforming to standards. The „Pitch (up to)“ is possible too at the expense of conformity. Please read additional notes.

Schnittwerte (Start) // Cutting parameters (start)		
fzm 0,04 mm	hmax 0,05 mm	Vc Seite/Page 638
Passende Klemmhalter auf Seite // Suitable toolholders on page 556, 557, 558, 559, 560, 561, 562, 563, 564		
Vergleichbare Werkzeuge auf Seite // Similar tools on page 466		
Bitte Hinweise im Anhang beachten // Please read add. notes ALL (Seite/Page 645), H03 (Seite/Page 647), H04 (Seite/Page 648), H05 (Seite/Page 648), H07 (S./P. 648)		


SP Legende
HM Legend
650

 Scan QR-Code
 Oder besuchen Sie // Or Visit www.simtek.info/cp/398

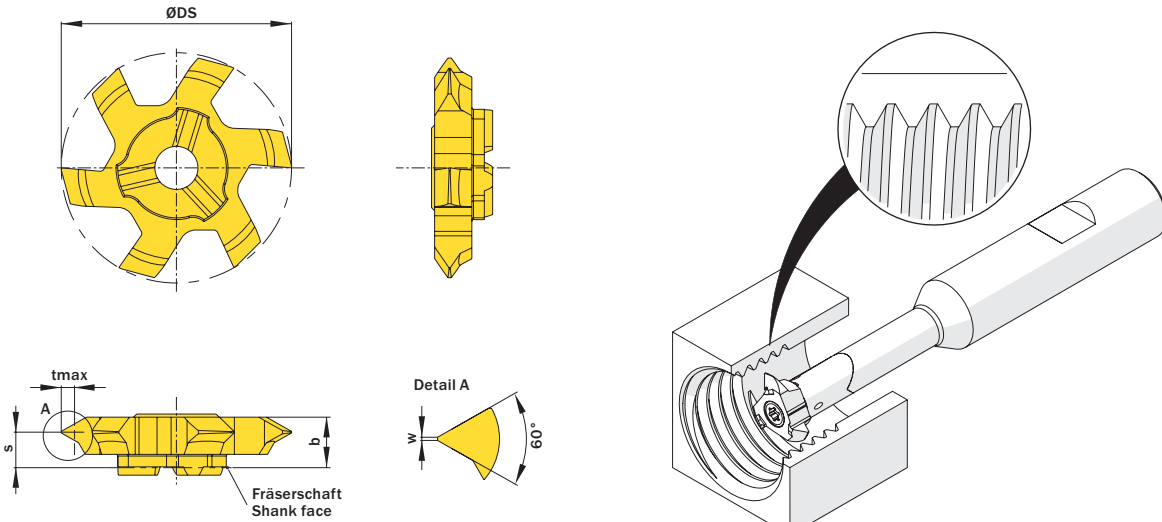


Abbildung zeigt / Drawing shows: V06.1525.01.28 M

Illustration zeigt beispielhafte Anwendungsmöglichkeit mit ähnlichem Werkzeug. Image shows exemplary application possibility with similar tool.

Ab Gewindgröße As of thread size	Steigung (von) Pitch (as of)	Steigung (bis) Pitch (up to)	Artikelnummer Part number	Webcode www.simtek.com/webcode	Unsere erste Wahl Our first choice		b	S	w	tmax	ØDS	ZEFP	Connectcode www.simtek.com/ccode		
					PM	KN							S	VD11.3	VD11.5
M33	1,5	2,5	V06.1525.01.28 M	AEDF	X800	GT42	6,5	5,1	0,19	1,6	27,7	6	VD12.7	VD13.5	VD14.0
M36	2,5	5,0	V06.3050.01.28 M	AN8W	X800	GT42	6,1	3,9	0,38	2,93	27,7	6	VD14.3	VD15.0	VD16.0

Bestellbeispiel // Order example: **V06.3050.01.28 M X800** (X800 = Schneidstoff // Grade)

Bitte beachten Sie die zusätzlichen Hinweise zu den Mehrbereichswerkzeugen im Infobereich rechts oben.
 Please read the additional notes mentioned in the information area on the top right corner of this page.

Die angegebene Gewindgrößeneignung bezieht sich auf die Startsteigung.
 The mentioned thread size „As of thread size“ is based on the starting pitch.

Mehr Infos zu den **Mehrbereichswerkzeugen** und deren **Gewindgrößeneignung** finden Sie auf Seite 649

More information about the **multi-purpose thread milling tools** and the **thread size suitability** can be found on page 649

Metrisches ISO-Gewindefräsen, Teilprofil

Ausgelegt als Mehrbereichswerkzeuge. Die angegebene „Steigung (von)“ ist normgerecht. Die „Steigung (bis)“ kann ebenfalls realisiert werden. Vgl. Hinweistexte.

Thread milling, metric ISO-Thread, partial profile

Multi-purpose milling inserts. The given „Pitch (as of)“ is conforming to standards. The „Pitch (up to)“ is possible too at the expense of conformity. Please read additional notes.

Schnittwerte (Start) // Cutting parameters (start)		
fzm 0,04 mm	hmax 0,05 mm	Vc Seite/Page 638
Passende Klemmhalter auf Seite // Suitable toolholders on page 556, 557, 558, 559, 560, 561, 562, 563, 564		
Vergleichbare Werkzeuge auf Seite // Similar tools on page 466		
Bitte Hinweise im Anhang beachten // Please read add. notes ALL (Seite/Page 645), H03 (Seite/Page 647), H04 (Seite/Page 648), H07 (Seite/Page 648)		

SP

Legende
Legend

HM

Legende
Legend

650

Scan QR-Code

Oder besuchen Sie // Or Visit www.simtek.info/cp/399

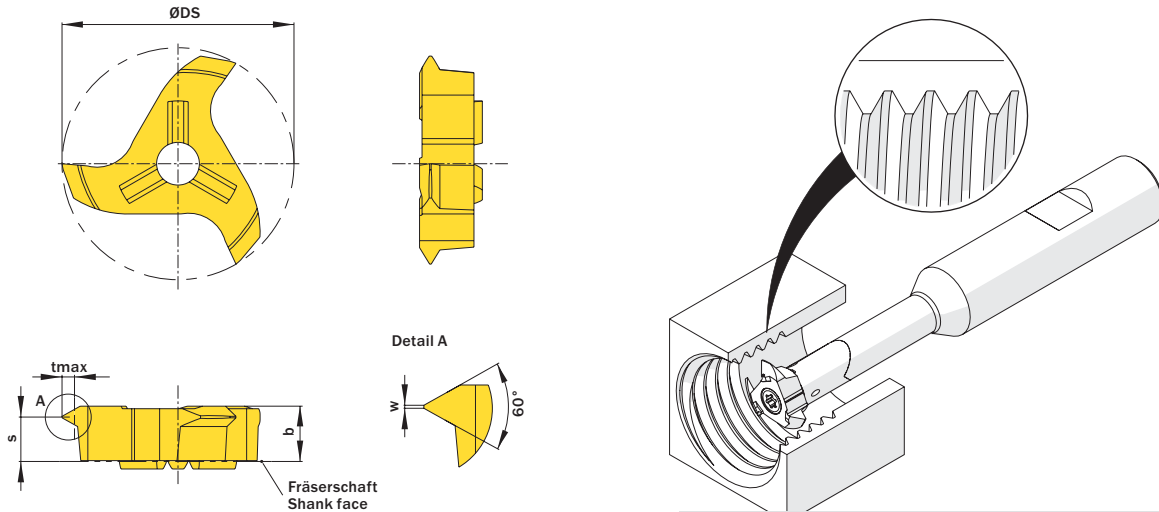


Abbildung zeigt / Drawing shows: V28.1525.01 M

Illustration zeigt beispielhafte Anwendungsmöglichkeit mit ähnlichem Werkzeug.
 Image shows exemplary application possibility with similar tool.

Ab Gewindegröße As of thread size	Steigung (von) Pitch (as of)	Steigung (bis) Pitch (up to)	Artikelnummer Part number	Webcode www.simtek.com/webcode	Unsere erste Wahl Our first choice		b	S	w	tmax	ØDS	ZEFP	Connectcode www.simtek.com/ccode
					P	M							
M33	1,0	2,0	V28.0720.01 M	AGS9	X800	GT42	6,6	4,6	0,12	1,2	27,7	3	
M33	1,5	2,5	V28.1525.01 M	AD0Y	X800	GT42	6,6	4,3	0,18	1,49	27,7	3	VD11.3 VD11.5 VD12.0
M36	2,5	5,0	V28.3050.01 M	ANX4	X800	GT42	6,6	4,1	0,37	2,93	27,7	3	VD12.7 VD13.5 VD14.0
M39	4,0	6,0	V28.5060.01 M	AJVV	X800	GT42	6,6	3,6	0,5	4,6	27,7	3	VD14.3 VD15.0 VD16.0

Bestellbeispiel // Order example: **V28.5060.01 M X800** (X800 = Schneidstoff // Grade)

Bitte beachten Sie die zusätzlichen Hinweise zu den Mehrbereichswerkzeugen im Infobereich rechts oben.
 Please read the additional notes mentioned in the information area on the top right corner of this page.

Die angegebene Gewindegrößeneignung bezieht sich auf die Startsteigung.
 The mentioned thread size „As of thread size“ is based on the starting pitch.

Mehr Infos zu den **Mehrbereichswerkzeugen** und deren **Gewindegrößeneignung** finden Sie auf Seite 649

More information about the **multi-purpose thread milling tools** and the **thread size suitability** can be found on page 649

Allgemeines Nutfräsen

Nutfräsen gerader Nutformen.
 Geeignet ab Bohrungsdurchmesser 32,0 mm.

General Groove Milling

General groove milling.
 For use in bores as of minimum bore diameter 32,0 mm.

Schnittwerte (Start) // Cutting parameters (start)		
f _{zm} 0,04 mm	h _{max} 0,05 mm	V _c Seite/Page 638
Passende Klemmhalter auf Seite // Suitable toolholders on page 556, 557, 558, 559, 560, 561, 563		
Vergleichbare Werkzeuge auf Seite // Similar tools on page 461		
Bitte Hinweise im Anhang beachten // Please read add. notes ALL (Seite/Page 645), H01 (Seite/Page 646), H07 (Seite/Page 648)		

SP Legende
HM Legend

Scan
 Oder besuchen Sie // Or Visit
www.simtek.info/cp/430

Legende Legend **650**

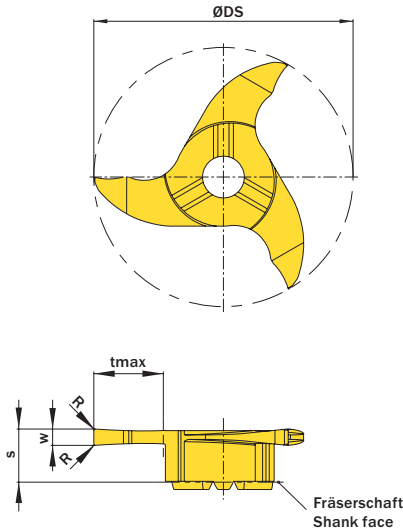


Abbildung zeigt / Drawing shows: V32.0200.02 G

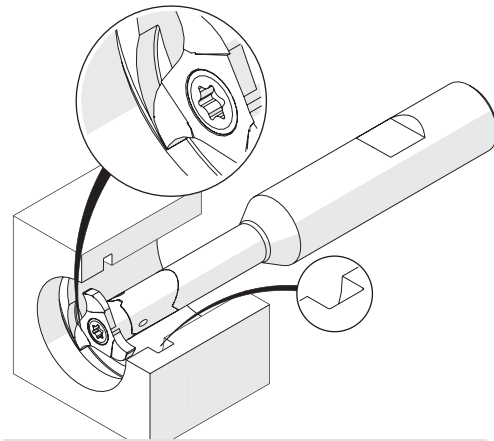


Illustration zeigt beispielhafte Anwendungsmöglichkeit mit ähnlichem Werkzeug.
 Image shows exemplary application possibility with similar tool.

w ^{+0,02} mm	Nuttenbreite Nominal width of groove mm	R mm	ØDmin (Min. Bohrung) ØDmin (min. bore) mm	Artikelnummer Part number	Webcode www.simtek.com/webcode	Unsere erste Wahl Our first choice		t _{max} mm	s mm	ØDS mm	ZEFP	Connectcode www.simtek.com/ccode
						P M K N S	G T 42					
1,5	-	0,2	32,0	V32.0150.02.11 G	A3U5	X800	G T 42	10,0	6,5	31,7	3	VD11.3 VD11.5 new
1,6	-	0,2	32,0	V32.0160.02.11 G	A3U7	X800	G T 42	10,0	6,5	31,7	3	VD11.3 VD11.5 new
2,0	-	0,2	32,0	V32.0200.02 G	AE2X	X800	G T 42	8,5	6,5	31,7	3	VD14.0 VD14.3
2,0	-	0,2	32,0	V32.0200.02.11 G	AX0G	X800	G T 42	10,0	6,5	31,7	3	VD11.3 VD11.5
2,5	-	0,2	32,0	V32.0250.02 G	AAPW	X800	G T 42	8,5	6,5	31,7	3	VD14.0 VD14.3
3,0	-	0,2	32,0	V32.0300.02 G	ACYJ	X800	G T 42	8,5	6,5	31,7	3	VD14.0 VD14.3
3,0	-	0,2	32,0	V32.0300.02.11 G	A0ZA	X800	G T 42	10,0	6,5	31,7	3	VD11.3 VD11.5

Bestellbeispiel // Order example: **V32.0300.02 G X800** (X800 = Schneidstoff // Grade)



V32. w, 1/100 mm, 4 Stellen/Digits · R, 1/100 mm, 3 Stellen/Digits Toleranz // Tolerance
 Beispielartikelnummer // Example Part number: **V32.0179.030 XG**

simmill AX
simmill PMX
simmill PX
simmill SX
simmill UX
simmill VX
simmill H2
simmill K2
simmill MX
simmill OS
Index

Allgemeines Nutfräsen in Leichtmetall

Nutfräsen gerader Nutformen in Bohrungen ab Bohrungsdurchmesser 32,0 mm. Durch hochpositive Schneidengeometrie besonders geeignet für Leichtmetalle.

General Groove Milling in light alloys

General groove milling in bores as of bore diameter 32,0 mm. High positive rake angle for use in light alloys.

Schnittwerte (Start) // Cutting parameters (start)

f _{zm} 0,03 mm	h _{max} 0,04 mm	V _c Seite/Page 638
----------------------------	-----------------------------	----------------------------------

Passende Klemmhalter auf Seite // Suitable toolholders on page
556, 557, 558, 559, 560, 561, 563

Vergleichbare Werkzeuge auf Seite // Similar tools on page
462

Bitte Hinweise im Anhang beachten // Please read add. notes

ALL (Seite/Page 645), H01 (Seite/Page 646), H07 (Seite/Page 648)



Legende Legend **650**

Scan QR-Code

Oder besuchen Sie // Or Visit www.simtek.info/cp/379

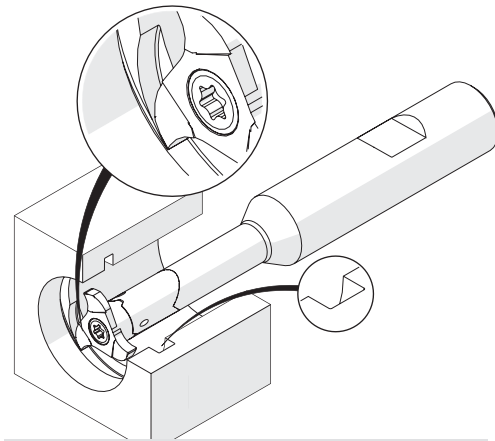
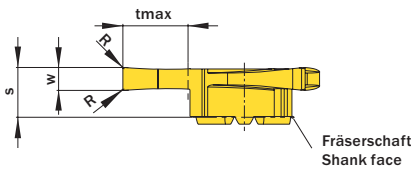
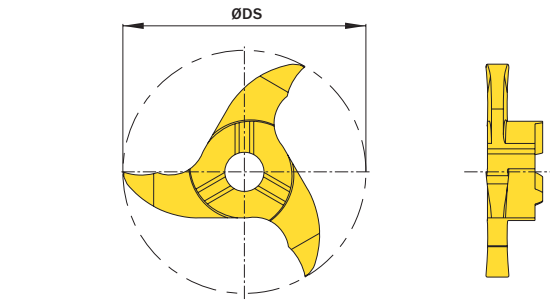


Illustration zeigt beispielhafte Anwendungsmöglichkeit mit ähnlichem Werkzeug. Image shows exemplary application possibility with similar tool.

Abbildung zeigt / Drawing shows: V32.0300.42 C

w ^{+0,02}	Nuttenbreite Nominal width of groove	R	ØDmin (Min. Bohrung) ØDmin (min. bore)	Artikelnummer Part number	Webcode www.simtek.com/webcode	Unsere erste Wahl Our first choice	t _{max}	s	ØDS	ZEFP	Connectcode www.simtek.com/ccode
mm	mm	mm	mm			P M K N S	mm	mm	mm		
2,0	-	0,2	32,0	V32.0200.42 C	AGWK	X808 HT42	8,5	6,5	31,7	3	VD14.0 VD14.3
2,5	-	0,2	32,0	V32.0250.42 C	AC45	X808 HT42	8,5	6,5	31,7	3	VD14.0 VD14.3
3,0	-	0,2	32,0	V32.0300.42 C	ACQ3	X808 HT42	8,5	6,5	31,7	3	VD14.0 VD14.3
6,0	-	0,2	32,0	V32.0600.42 C	ADHB	X808 HT42	8,5	6,5	31,7	3	VD14.0 VD14.3

Bestellbeispiel // Order example: **V32.0600.42 C X808** (X808 = Schneidstoff // Grade)



V32. **w, 1/100 mm, 4 Stellen/Digits** . **R, 1/100 mm, 3 Stellen/Digits** **Toleranz // Tolerance C**

Beispielartikelnummer // Example Part number: **V32.0179.030 XG C**

Allgemeines Nutfräsen in Leichtmetall

Nutfräsen gerader Nutformen in Bohrungen ab Bohrungsdurchmesser 33,0 mm. Durch hochpositive Schneidengeometrie besonders geeignet für Leichtmetalle.

General Groove Milling in light alloys

General groove milling in bores as of bore diameter 33,0 mm. High positive rake angle for use in light alloys.

Schnittwerte (Start) // Cutting parameters (start)		
fzm 0,01 mm	hmax 0,02 mm	Vc Seite/Page 638
Passende Klemmhalter auf Seite // Suitable toolholders on page 556, 557, 558, 559, 560, 561, 562, 563, 564		
Vergleichbare Werkzeuge auf Seite // Similar tools on page 462		
Bitte Hinweise im Anhang beachten // Please read add. notes ALL (Seite/Page 645), H01 (Seite/Page 646), H07 (Seite/Page 648)		

SP
HM

LM

Legende
Legend **650**

Scan
QR-Code

Oder besuchen Sie // Or Visit
www.simtek.info/cp/431

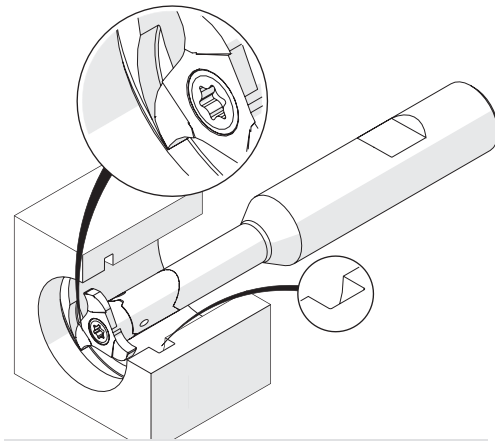
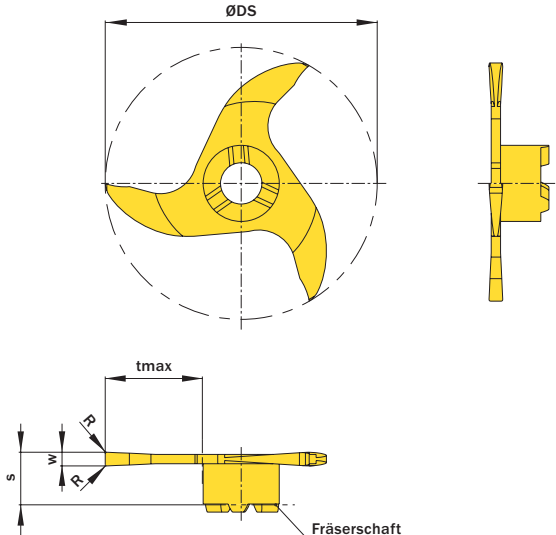


Illustration zeigt beispielhafte Anwendungsmöglichkeit mit ähnlichem Werkzeug.
Image shows exemplary application possibility with similar tool.

Abbildung zeigt / Drawing shows: V33.0170.42.10 C

w _{-0,02} mm	Nuttenbreite Nominal width of groove mm	R mm	ØDmin (Min. Bohrung) ØDmin (min. bore) mm	Artikelnummer Part number	Webcode www.simtek.com/webcode	Unsere erste Wahl Our first choice P M K N S	tmax mm	S mm	ØDS mm	ZFP	Connectcode www.simtek.com/ccode
▼ tmax = 10,0 mm											
1,1	-	0,2	33,0	V33.0110.42.10 C	AE5V	X808 HT42	10,0	6,5	32,7	3	VD12.0
1,2	-	0,2	33,0	V33.0120.42.10 C	AFJN	X808 HT42	10,0	6,5	32,7	3	VD12.0
1,32	-	0,2	33,0	V33.0132.42.10 C	AEKN	X808 HT42	10,0	6,5	32,7	3	VD12.0
1,5	-	0,2	33,0	V33.0150.42.10 C	AHVT	X808 HT42	10,0	6,5	32,7	3	VD12.0
1,6	-	0,2	33,0	V33.0160.42.10 C	AB3H	X808 HT42	10,0	6,5	32,7	3	VD12.0
1,7	-	0,2	33,0	V33.0170.42.10 C	ABQM	X808 HT42	10,0	6,5	32,7	3	VD12.0
2,0	-	0,2	33,0	V33.0200.42.10 C	AN1P	X808 HT42	10,0	6,5	32,7	3	VD12.0
2,5	-	0,2	33,0	V33.0250.42.10 C	AB9V	X808 HT42	10,0	6,5	32,7	3	VD12.0
▼ tmax = 12,0 mm											
1,7	-	0,2	33,9	V33.0170.42.12 C	ANBT	X808 HT42	12,0	6,5	33,6	3	VD09.0
2,0	-	0,2	33,9	V33.0200.42.12 C	AY6T	X808 HT42	12,0	6,5	33,6	3	VD09.0
2,5	-	0,2	33,9	V33.0250.42.12 C	APCK	X808 HT42	12,0	6,5	33,6	3	VD09.0

Bestellbeispiel // Order example: **V33.0170.42.12 C X808** (X808 = Schneidstoff // Grade)

simmill AX
simmill PMX
simmill PX
simmill SX
simmill UX
simmill VX
simmill H2
simmill K2
simmill MX
simmill OS
Index

Allgemeines Nutfräsen

Nutfräsen gerader Nutformen.
Geeignet ab Bohrungsdurchmesser 35,0 mm.

General Groove Milling

General groove milling.
For use in bores as of minimum bore diameter 35,0 mm.

Schnittwerte (Start) // Cutting parameters (start)		
fzm 0,03 mm	hmax 0,04 mm	Vc Seite/Page 638

Passende Klemmhalter auf Seite // Suitable toolholders on page
556, 557, 558, 559, 560, 561, 563

Vergleichbare Werkzeuge auf Seite // Similar tools on page
461

Bitte Hinweise im Anhang beachten // Please read add. notes

ALL (Seite/Page 645), H01 (Seite/Page 646), H05 (Seite/Page 648), H07 (Seite/Page 648)

SP

Legende

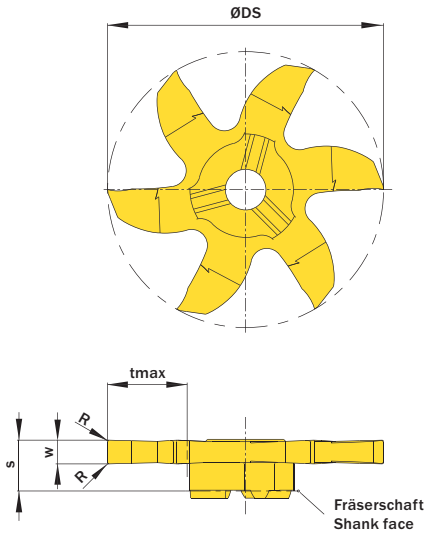
HM

Legend

Scan QR-Code

650

Oder besuchen Sie // Or Visit
www.simtek.info/cp/382



Fräserschaft
Shank face

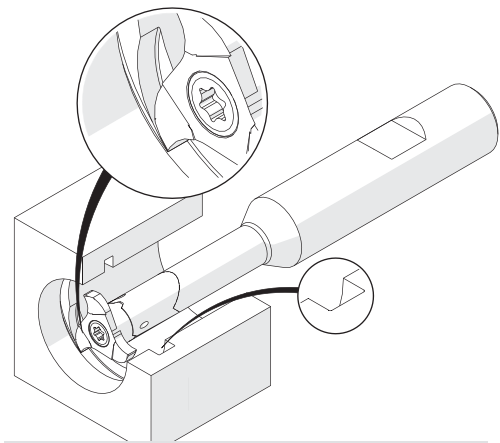


Illustration zeigt beispielhafte Anwendungsmöglichkeit mit ähnlichem Werkzeug.
Image shows exemplary application possibility with similar tool.

Abbildung zeigt / Drawing shows: V06.0300.020.35 G

w ^{+0,02}	Nuttenbreite Nominal width of groove	R	ØDmin (Min. Bohrung) ØDmin (min. bore)	Artikelnummer Part number	Webcode www.simtek.com/webcode	Unsere erste Wahl Our first choice	tmax	S	ØDS	ZEFP	Connectcode www.simtek.com/ccode
mm	mm	mm	mm			P M K N S	mm	mm	mm		
1,5	-	0,1	35,0	V06.0150.010.35 G	AHDS	X800 GT42	10,0	6,2	34,7	6	VD14.0 VD14.3
2,0	-	0,2	35,0	V06.0200.020.35 G	AGDQ	X800 GT42	10,0	6,2	34,7	6	VD14.0 VD14.3
2,5	-	0,2	35,0	V06.0250.020.35 G	AF56	X800 GT42	10,0	6,2	34,7	6	VD14.0 VD14.3
3,0	-	0,2	35,0	V06.0300.020.35 G	AMN1	X800 GT42	10,0	6,2	34,7	6	VD14.0 VD14.3

Bestellbeispiel // Order example: **V06.0150.010.35 G X800** (X800 = Schneidstoff // Grade)



V06. w, 1/100 mm, 4 Stellen/Digits . R, 1/100 mm, 3 Stellen/Digits .35 Toleranz // Tolerance

Beispielartikelnummer // Example Part number: **V06.0179.030.35 XG**

Allgemeines Nutfräsen

Nutfräsen gerader Nutformen.
 Geeignet ab Bohrungsdurchmesser 37,0 mm.

General Groove Milling

General groove milling.
 For use in bores as of minimum bore diameter 37,0 mm.

Schnittwerte (Start) // Cutting parameters (start)		
fzm 0,03 mm	hmax 0,04 mm	Vc Seite/Page 638
Passende Klemmhalter auf Seite // Suitable toolholders on page 556, 557, 558, 559, 560, 561, 562, 563, 564		
Vergleichbare Werkzeuge auf Seite // Similar tools on page 461		
Bitte Hinweise im Anhang beachten // Please read add. notes ALL (Seite/Page 645), H01 (Seite/Page 646), H05 (Seite/Page 648), H07 (Seite/Page 648)		

SP

Legende

HM

Legend

650

Scan QR-Code

Oder besuchen Sie // Or Visit www.simtek.info/cp/383

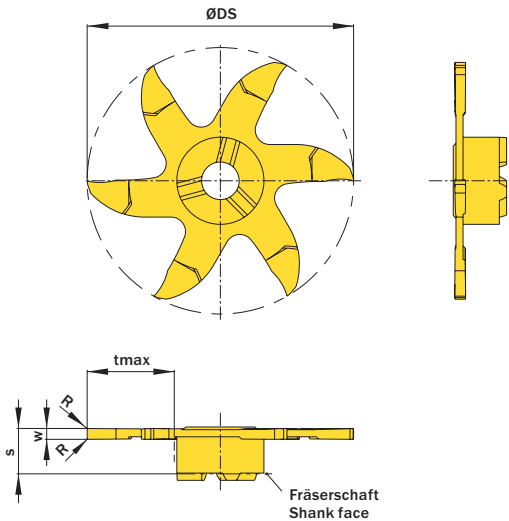


Abbildung zeigt / Drawing shows: V06.0150.010.37 G

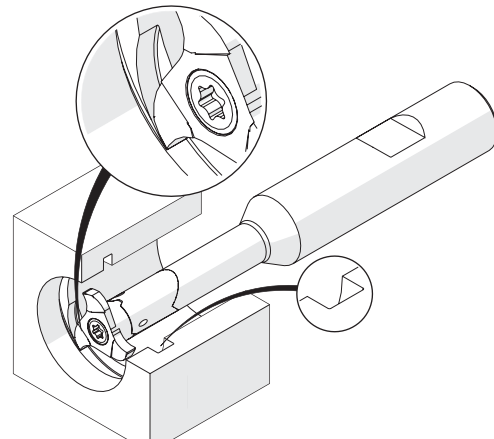


Illustration zeigt beispielhafte Anwendungsmöglichkeit mit ähnlichem Werkzeug.
 Image shows exemplary application possibility with similar tool.

w ^{+0,02}	Nuttenbreite Nominal width of groove	R	ØDmin (Min. Bohrung) ØDmin (min. bore)	Artikelnummer Part number	Webcode www.simtek.com/webcode	Unsere erste Wahl Our first choice	tmax	s	ØDS	ZEFP	Connectcode www.simtek.com/ccode
mm	mm	mm	mm			P M K N S	mm	mm	mm		
▼ ØDmin (Min. Bohrung) // ØDmin (min. bore) = 37,0 mm											
1,0	-	0,1	37,0	V06.0100.010.37 G	AJ2K	X800 GT42	12,0	6,2	36,7	6	VD12.0
1,5	-	0,1	37,0	V06.0150.010.37 G	AFW6	X800 GT42	12,0	6,2	36,7	6	VD12.0
▼ ØDmin (Min. Bohrung) // ØDmin (min. bore) = 40,0 mm											
1,0	-	0,1	40,0	V06.0100.010.40 G	AWX9	X800 GT42	13,5	6,2	39,7	6	VD12.0
1,5	-	0,1	40,0	V06.0150.010.40 G	AWX8	X800 GT42	13,5	6,2	39,7	6	VD12.0

Bestellbeispiel // Order example: **V06.0150.010.37 G X800** (X800 = Schneidstoff // Grade)



V06. w, 1/100 mm, 4 Stellen/Digits . R, 1/100 mm, 3 Stellen/Digits .37 Toleranz // Tolerance
 Beispielpartikelnummer // Example Part number: **V06.0179.030.37 XG**

simmill AX
simmill PMX
simmill PX
simmill SX
simmill UX
simmill VX
simmill H2
simmill K2
simmill MX
simmill OS
Index

Nut-, Trenn- und Schlitzfräsen

Nutfräsen gerader Nutformen.
 Geeignet ab Bohrungsdurchmesser 37,0 mm.

Groove and Key Way Milling

General groove milling.
 For use in bores as of minimum bore diameter 37,0 mm.

Schnittwerte (Start) // Cutting parameters (start)		
fzm	hmax	Vc
0,01 mm	0,02 mm	Seite/Page 638

Passende Klemmhalter auf Seite // Suitable toolholders on page
556, 557, 558, 559, 560, 561, 562, 563, 564

Vergleichbare Werkzeuge auf Seite // Similar tools on page
461

Bitte Hinweise im Anhang beachten // Please read add. notes
ALL (Seite/Page 645), H01 (Seite/Page 646), H05 (Seite/Page 648), H07 (Seite/Page 648)

SP

Legende

HM

Legend

650

Scan QR-Code

Oder besuchen Sie // Or Visit www.simtek.info/cp/384

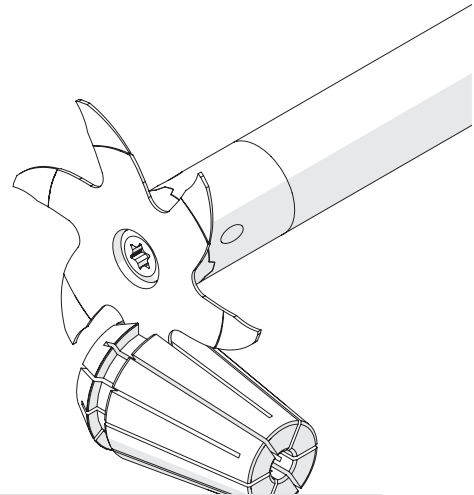
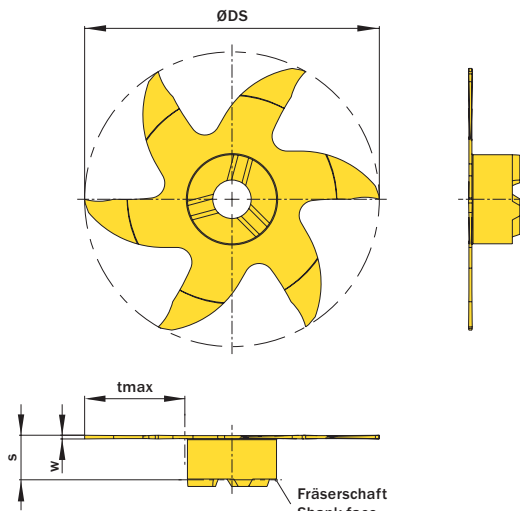


Illustration zeigt beispielhafte Anwendungsmöglichkeit mit ähnlichem Werkzeug.
 Image shows exemplary application possibility with similar tool.

Abbildung zeigt / Drawing shows: V06.0050.000.40 G

w ^{+0,05}	Nuttenbreite Nominal width of groove	R	ØDmin (Min.-Bohrung) ØDmin (min. bore)	Artikelnummer Part number	Webcode www.simtek.com/webcode	Unsere erste Wahl Our first choice	tmax	S	ØDS	ZEFP	Connectcode www.simtek.com/ccode
mm	mm	mm	mm			P M K N S	mm	mm	mm		
▼ w = 0,4 mm											
0,4	-	-	40,0	V06.0040.000.40 G	AWAG	X800 GT42	13,5	6,0	39,7	6	VD12.0
▼ w = 0,5 mm											
0,5	-	-	37,0	V06.0050.000.37 G	AA60	X800 GT42	12,0	6,0	36,7	6	VD12.0
0,5	-	-	40,0	V06.0050.000.40 G	AXBF	X800 GT42	13,5	6,0	39,7	6	VD12.0
▼ w = 0,6 mm											
0,6	-	-	37,0	V06.0060.000.37 G	AA5V	X800 GT42	12,0	5,7	36,7	6	VD12.0
0,6	-	-	40,0	V06.0060.000.40 G	AXBG	X800 GT42	13,5	5,7	39,7	6	VD12.0
▼ w = 0,8 mm											
0,8	-	-	37,0	V06.0080.000.37 G	AN39	X800 GT42	12,0	5,9	36,7	6	VD12.0
0,8	-	-	40,0	V06.0080.000.40 G	AXBH	X800 GT42	13,5	5,9	39,7	6	VD12.0

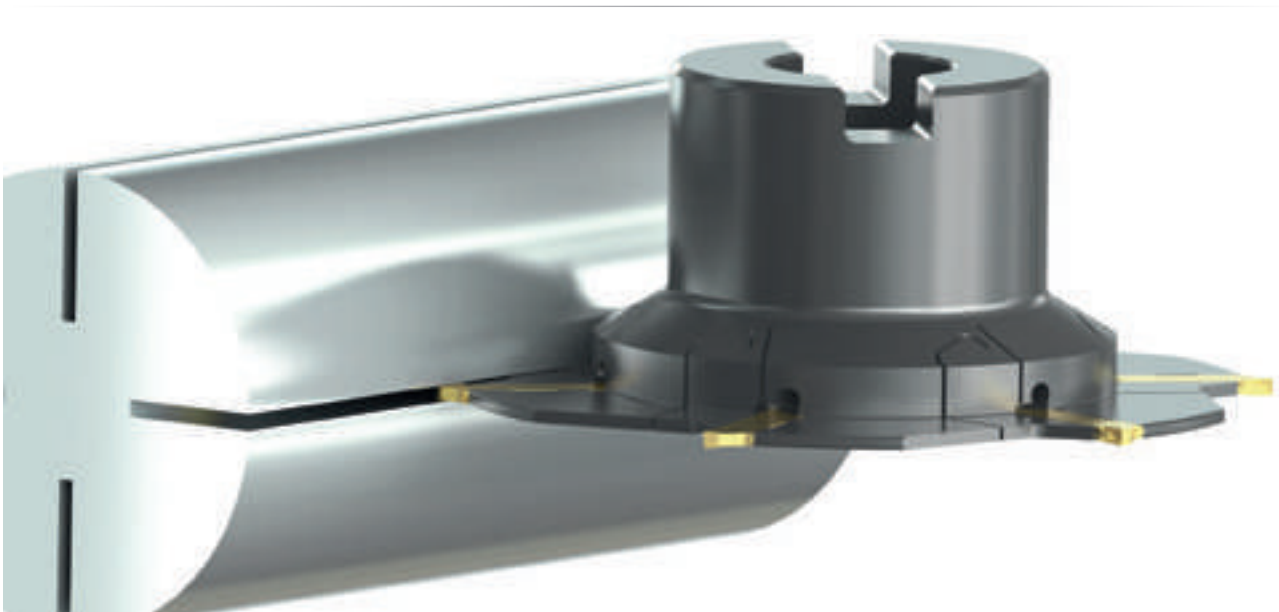
Bestellbeispiel // Order example: **V06.0080.000.37 G X800** (X800 = Schneidstoff // Grade)



V06. w, 1/100 mm, 4 Stellen/Digits . R, 1/100 mm, 3 Stellen/Digits .37 Toleranz // Tolerance
 Beispielartikelnummer // Example Part number: **V06.0179.030.37 XG**

Das Werkzeugsystem simmill H2 The Tool System simmill H2

Aktives Spannsystem für 3,6-fache Frästiefen*, einfache Handhabung und hohe Prozesssicherheit.
Active and easy-to-use clamping system for 3,6 times higher cutting depths* and high process reliability.



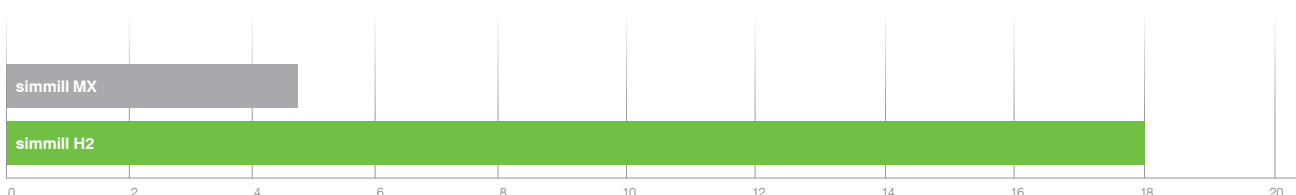
Die präzisionsgeschliffenen simmill H2 Wendeschneidplatten mit zwei Schneiden bieten, in Kombination mit dem aktiven und einfach zu handhabenden Spannsystem, eine sehr hohe Prozesssicherheit und eine sehr gute Plan- und Rundlaufgenauigkeit. Das stabile Spannsystem ermöglicht bis zu 3,6-fache Frästiefen*, bereits ab einer Schneidenbreite von 1,3 mm.

- Mit zwei geschliffenen Schneiden bereits ab 1,3 mm Breite
- Maximale Frästiefe bis zu 18,0 mm
- Schneidkreis von 100,0 mm

simmill H2 provides very high process reliability and tight axial and radial runout tolerances thanks to precision ground two-edged indexable cutting inserts in combination with an active and easy-to-use clamping system. The stable clamping system provides up to 3,6 times higher cutting depths* as of cutting edge width 1,3 mm.

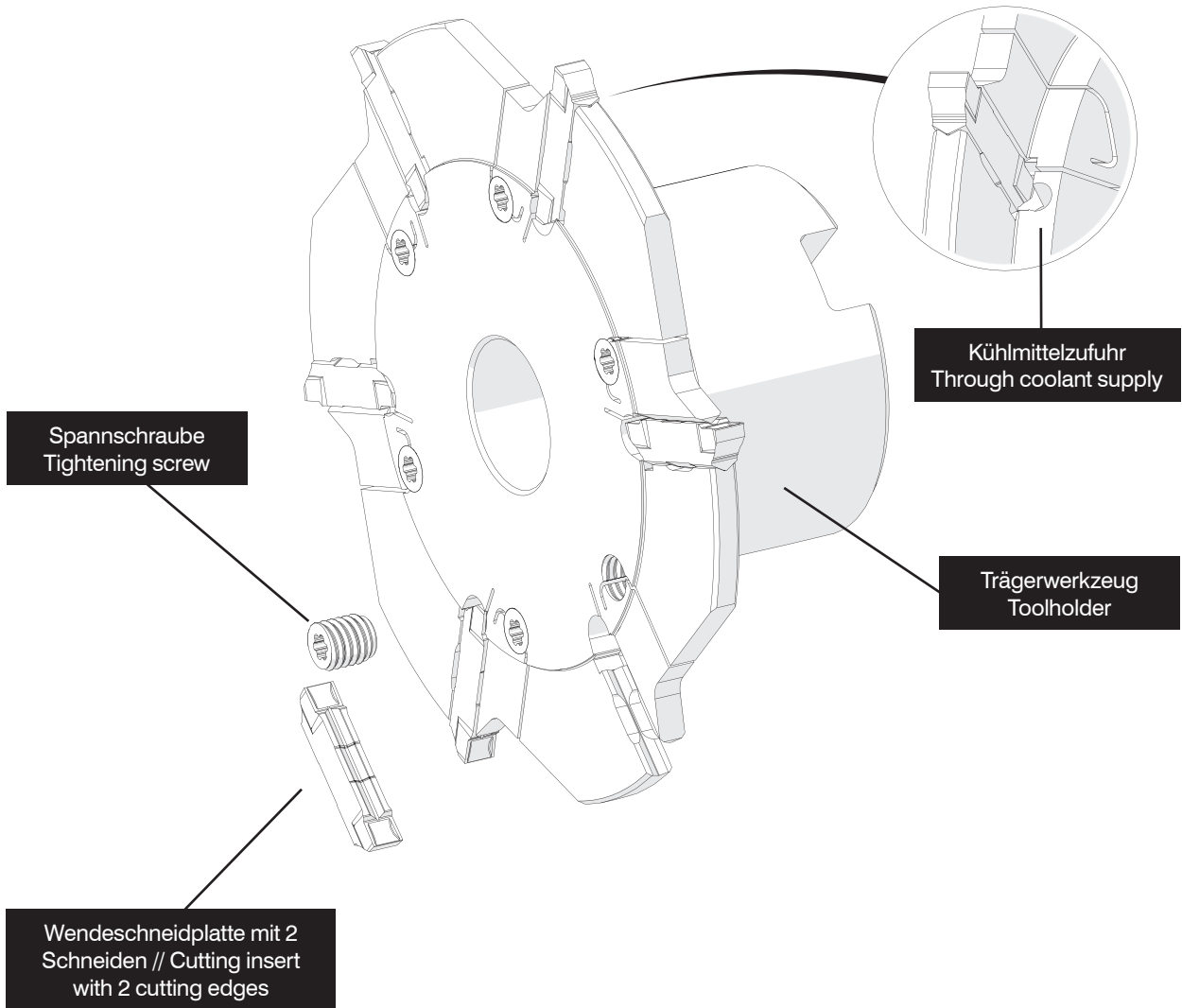
- Precision ground cutting edges as of cutting edge width 1,3 mm
- Maximum cutting depth of 18,0 mm
- Cutting diameter of 100,0 mm

Frästiefe in mm // milling depth in mm



* im Vergleich zu // Compared to simmill MX

Das Werkzeugsystem im Detail The Tool System in Detail



Trennfräser

Fräserdorn-Aufnahme.

Slotting Cutter

Milling arbor fixation.

Anzugsmoment (Schraube) // Tightening torque (screw)

3,0 Nm

Bitte Hinweise im Anhang beachten // Please read add. notes

ALL (Seite/Page 645), H07 (Seite/Page 648)



Legende
Legend **650**



Oder besuchen Sie // Or Visit
www.simtek.info/cp/1279

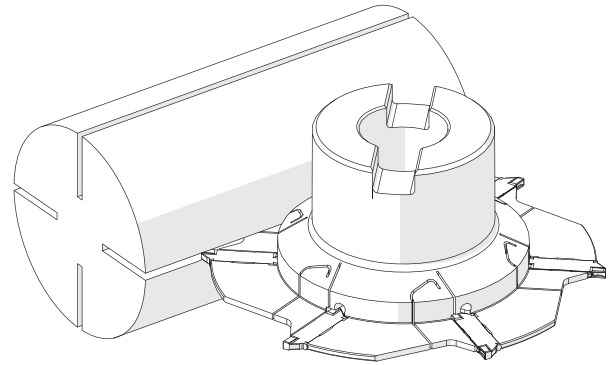
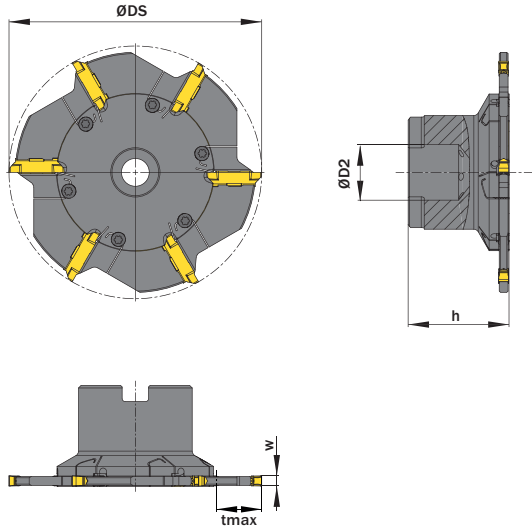


Illustration zeigt beispielhafte Anwendungsmöglichkeit mit ähnlichem Werkzeug.
Image shows exemplary application possibility with similar tool.

Abbildung zeigt / Drawing shows: MH2.80.0100.06.40.IC R

ØDS	ØD2	Artikelnummer Part number	Webcode www.simtek.com/webcode	ZEFP	h	tmax	w ≥	w ≤	Schraube Screw	Schraubenschlüssel Screw driver	Connectcode www.simtek.com/ccode	
mm	mm				mm	mm	mm	mm				
100,0	22,0	MH2.80.0100.06.15.IC R	A206	6	40,0	18,0	-	1,9	MH2.S.06.65 T15F	T15F	MH2.15	
100,0	22,0	MH2.80.0100.06.20.IC R	A207	6	40,0	18,0	1,91	2,4	MH2.S.06.65 T15F	T15F	MH2.20	
100,0	22,0	MH2.80.0100.06.25.IC R	A208	6	40,0	18,0	2,41	2,9	MH2.S.06.65 T15F	T15F	MH2.25	
100,0	22,0	MH2.80.0100.06.30.IC R	A209	6	40,0	18,0	2,91	3,8	MH2.S.06.65 T15F	T15F	MH2.30	
100,0	22,0	MH2.80.0100.06.40.IC R	A21A	6	40,0	18,0	3,81	5,0	MH2.S.06.65 T15F	T15F	MH2.40	
102,0	25,4	MH2.80.0102.06.15.IC R	A6MT	6	40,0	18,0	-	1,9	MH2.S.06.65 T15F	T15F	MH2.15	new inch
102,0	25,4	MH2.80.0102.06.20.IC R	A6MV	6	40,0	18,0	1,91	2,4	MH2.S.06.65 T15F	T15F	MH2.20	new inch
102,0	25,4	MH2.80.0102.06.25.IC R	A6MX	6	40,0	18,0	2,41	2,9	MH2.S.06.65 T15F	T15F	MH2.25	new inch
102,0	25,4	MH2.80.0102.06.30.IC R	A6MZ	6	40,0	18,0	2,91	3,8	MH2.S.06.65 T15F	T15F	MH2.30	new inch
102,0	25,4	MH2.80.0102.06.40.IC R	A6M1	6	40,0	18,0	3,81	5,0	MH2.S.06.65 T15F	T15F	MH2.40	new inch

Bestellbeispiel // Order example: MH2.80.0100.06.15.IC R (R = Rechte Ausführung // Right hand version)

simmill AX

simmill PMX

simmill PX

simmill SX

simmill UX

simmill VX

simmill H2

simmill K2

simmill MX

simmill OS

Index

Nut-, Trenn- und Schlitzfräsen

Zweischneidige Wendeschneidplatten zum Nut-, Trenn- und Schlitzfräsen ab Schneidenbreite 1,5 mm.

Groove and slot milling

Two-edged indexable cutting inserts for general groove milling and slot milling with cutting edge widths as of 1,5 mm.

Passende Klemmhalter auf Seite // Suitable toolholders on page **603**

Bitte Hinweise im Anhang beachten // Please read add. notes

ALL (Seite/Page 645)



SP
HM

Legende
Legend **650**



Scan
QR-Code

Oder besuchen Sie // Or Visit
www.simtek.info/cp/1280

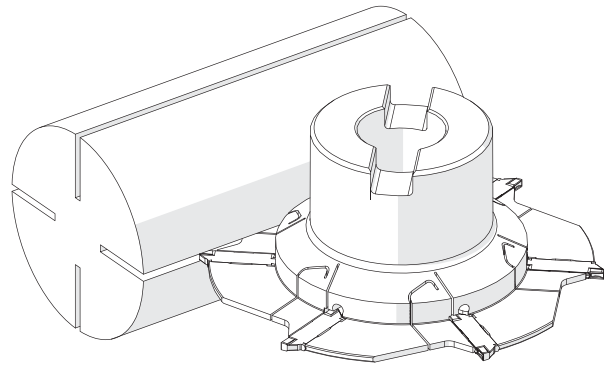
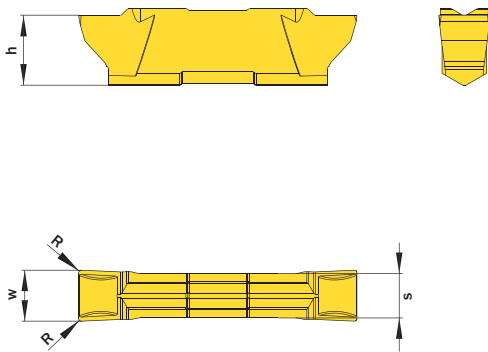


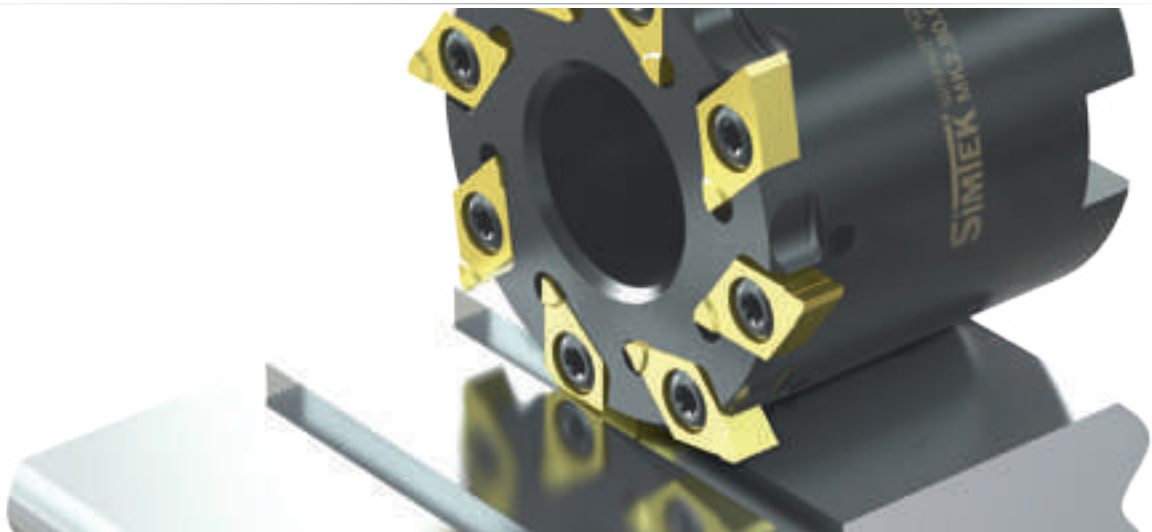
Abbildung zeigt / Drawing shows: MH2.400.020 GG

$w^{-0,02}$ mm	R mm	Artikelnummer Part number	Webcode www.simtek.com/webcode	Unsere erste Wahl Our first choice P M K N S	h mm	s mm	Connectcode www.simtek.com/code
▼ R = 0,05 mm							
1,5	0,05	MH2.150.005 GG	A2DM	X800 GT42	5,5	1,15	MH2.15
2,0	0,05	MH2.200.005 GG	A2DN	X800 GT42	5,5	1,6	MH2.20
2,5	0,05	MH2.250.005 GG	A2DP	X800 GT42	5,5	2,1	MH2.25
3,0	0,05	MH2.300.005 GG	A2DQ	X800 GT42	5,5	2,6	MH2.30
▼ R = 0,2 mm							
1,5	0,2	MH2.150.020 GG	A2DS	X800 GT42	5,5	1,15	MH2.15
1,575	0,2	MH2.157.020 GG	A6ND	X800 GT42	5,5	1,15	MH2.15 <small>new inch</small>
2,0	0,2	MH2.200.020 GG	A2DT	X800 GT42	5,5	1,6	MH2.20
2,388	0,2	MH2.239.020 GG	A6NF	X800 GT42	5,5	1,6	MH2.20 <small>new inch</small>
2,5	0,2	MH2.250.020 GG	A2DU	X800 GT42	5,5	2,1	MH2.25
3,0	0,2	MH2.300.020 GG	A2DV	X800 GT42	5,5	2,6	MH2.30
3,175	0,2	MH2.318.020 GG	A6NH	X800 GT42	5,5	2,6	MH2.30 <small>new inch</small>
3,5	0,2	MH2.350.020 GG	A2DW	X800 GT42	5,5	2,6	MH2.30
4,0	0,2	MH2.400.020 GG	A2DX	X800 GT42	5,5	3,5	MH2.40
4,75	0,2	MH2.475.020 GG	A6NK	X800 GT42	5,5	3,5	MH2.40 <small>new</small>
5,0	0,2	MH2.500.020 GG	A2DY	X800 GT42	5,5	3,5	MH2.40
▼ R = 0,4 mm							
3,0	0,4	MH2.300.040 GG	A2DZ	X800 GT42	5,5	2,6	MH2.30
3,5	0,4	MH2.350.040 GG	A2D0	X800 GT42	5,5	2,6	MH2.30
4,0	0,4	MH2.400.040 GG	A2D1	X800 GT42	5,5	3,5	MH2.40
5,0	0,4	MH2.500.040 GG	A2D2	X800 GT42	5,5	3,5	MH2.40

Bestellbeispiel // Order example: **MH2.150.020 GG X800** (X800 = Schneidstoff // Grade)

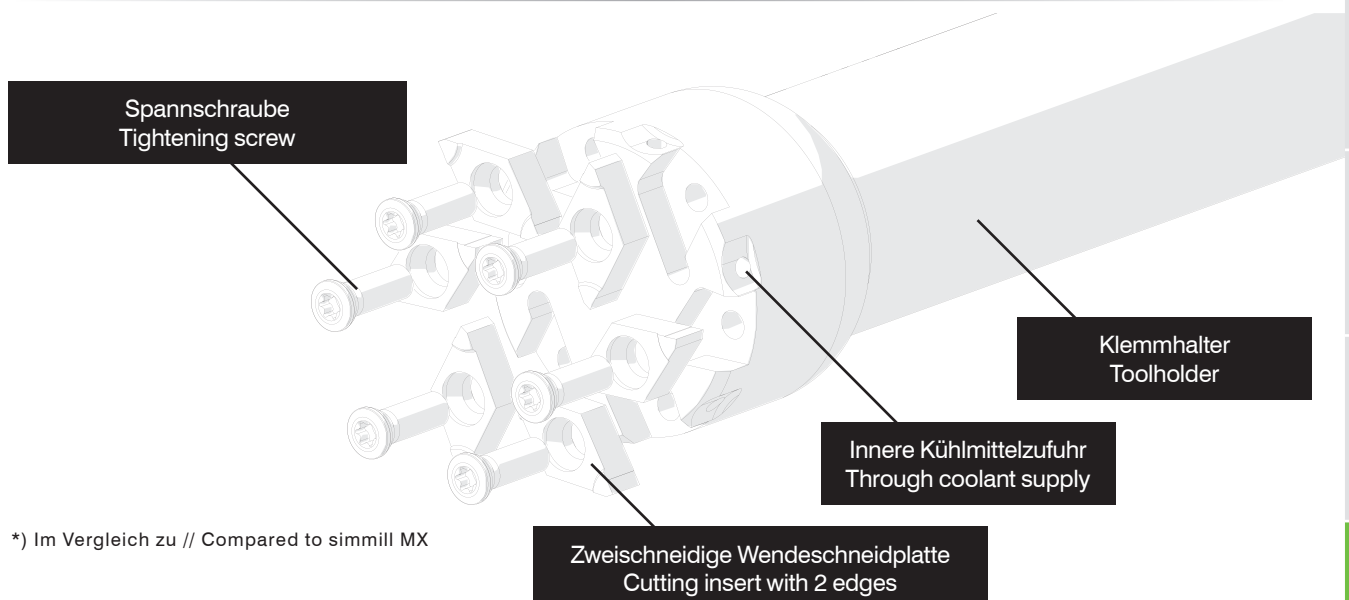
Das Werkzeugsystem simmill K2 The Tool System simmill K2

Bis zu 3 Mal mehr Schneiden bei gleichem Schneidkreis.*
Up to 3 times more cutting edges on equal cutting diameters.*



System bestehend aus Frälerschaft, Messerkopf oder Scheibenfräser und Hartmetall-Wendeschneidplatte mit 2 Schneiden. Bei der Innenbearbeitung geeignet für Bohrungen ab Durchmesser 39,0 mm.

System of milling cutter shank, milling cutter or disc milling cutter and indexable carbide cutting inserts with 2 cutting edges. Usable in bores as of diameter 39,0 mm



*) Im Vergleich zu // Compared to simmill MX

Fräserschaft (DIN 1835 - B25)

Weldon-Aufnahme nach DIN 1835 - B25.

Milling Cutter Shank (DIN 1835 - B25)

Weldon fixation according to DIN 1835 - B25.

Anzugsmoment (Schraube) // Tightening torque (screw)

3,0 Nm

Bitte Hinweise im Anhang beachten // Please read add. notes

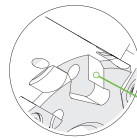
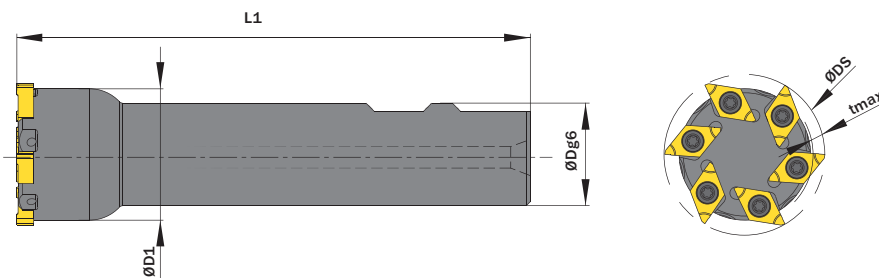
ALL (Seite/Page 645), H07 (Seite/Page 648)



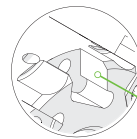
Legende
Legend **650**

Scan
QR-Code

Oder besuchen Sie // Or Visit
www.simtek.info/cp/1016



Connectcode MK2A.R.4.1
Plattensitztiefe 4,1 mm
Depth of insert seat 4,1 mm



Connectcode MK2A.R.6.1
Plattensitztiefe 6,1 mm. Siehe Info unten!
Depth of insert seat 6,1 mm. See info below!

Abbildung zeigt / Drawing shows: MK2.A.80.2539.06.04.IC R

ØDg6	ØDS	ZEFP	Artikelnummer Part number	Webcode www.simtek.com/webcode	Mit Kühlmittelzufuhr With through coolant supply	ØD1	L1	tmax	Schraube Screw	Schraubenschlüssel Screw driver	Connectcode www.simtek.com/code
mm	mm					mm	mm	mm			
25,4	39,0	6	MK2.A.80.1039.06.04.IC R	A4UD	Ja / Yes	32,0	125,0	3,0	M M3,5x11 T10F	T10F	MK2A.R.4.1
25,0	39,0	6	MK2.A.80.2539.06.04 R	AYSS	Nein / No	32,0	125,0	3,0	M M3,5x11 T10F	T10F	MK2A.R.4.1
25,0	39,0	6	MK2.A.80.2539.06.04.IC R	AWØE	Ja / Yes	32,0	125,0	3,0	M M3,5x11 T10F	T10F	MK2A.R.4.1
25,0	39,0	6	MK2.A.80.2539.06.06 R	AYST	Nein / No	32,0	125,0	3,0	M M3,5x11 T10F	T10F	MK2A.R.6.1
25,0	39,0	6	MK2.A.80.2539.06.06.IC R	AWØF	Ja / Yes	32,0	125,0	3,0	M M3,5x11 T10F	T10F	MK2A.R.6.1

Bestellbeispiel // Order example: **MK2.A.80.2539.06.04.IC R** (R = Rechte Ausführung // Right hand version)

Trägerwerkzeuge mit Connectcode „MK2.R.6.1“ sind für Individual-Schneidwerkzeuge vorgesehen.
Toolholder with Connectcode „MK2.R.6.1“ are provided for customized cutting tools.

new
inch

simmill AX

simmill PMX

simmill PX

simmill SX

simmill UX

simmill VX

simmill H2

simmill K2

simmill MX

simmill OS

Index

Messerkopf

Fräserdorn-Aufnahme.

Milling Cutter

Milling arbor fixation.

Anzugsmoment (Schraube) // Tightening torque (screw)

3,0 Nm

Bitte Hinweise im Anhang beachten // Please read add. notes

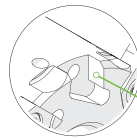
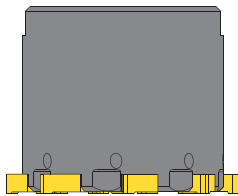
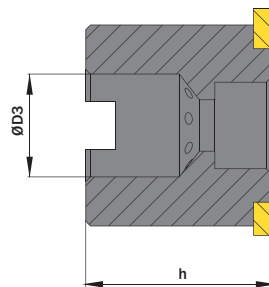
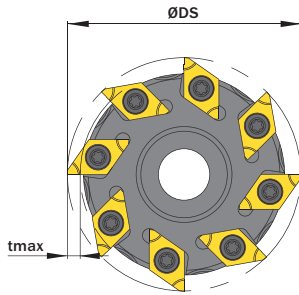
ALL (Seite/Page 645), H07 (Seite/Page 648)



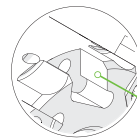
Legende
Legend **650**

Scan
QR-Code

Oder besuchen Sie // Or Visit
www.simtek.info/cp/1015



Connectcode MK2A.R.4.1
Plattensitztiefe 4,1 mm
Depth of insert seat 4,1 mm



Connectcode MK2A.R.6.1
Plattensitztiefe 6,1 mm. Siehe Info unten!
Depth of insert seat 6,1 mm. See info below!

Abbildung zeigt / Drawing shows: MK2.A.80.0050.08.04.IC R

ØDS mm	ZEFP	Artikelnummer Part number	Webcode www.simtek.com/webcode	Mit Kühlmittelzufuhr With through coolant supply	ØD3 mm	h mm	tmax mm	Schraube Screw	Schraubenschlüssel Screw driver	Connectcode www.simtek.com/code
39,0	6	MK2.A.80.0039.06.04.IC R	AW0J	Ja / Yes	16,0	36,0	3,0	M M3,5x11 T10F	T10F	MK2A.R.4.1
39,0	6	MK2.A.80.0039.06.06 R	AYSN	Nein / No	16,0	36,0	3,0	M M3,5x11 T10F	T10F	MK2A.R.6.1
39,0	6	MK2.A.80.0039.06.06.IC R	AW0K	Ja / Yes	16,0	36,0	3,0	M M3,5x11 T10F	T10F	MK2A.R.6.1
50,0	8	MK2.A.80.0050.08.04 R	AYSP	Nein / No	22,0	40,0	3,0	M M3,5x11 T10F	T10F	MK2A.R.4.1
50,0	8	MK2.A.80.0050.08.04.IC R	AW0G	Ja / Yes	22,0	40,0	3,0	M M3,5x11 T10F	T10F	MK2A.R.4.1
50,0	8	MK2.A.80.0050.08.06 R	AYSQ	Nein / No	22,0	40,0	3,0	M M3,5x11 T10F	T10F	MK2A.R.6.1
50,0	8	MK2.A.80.0050.08.06.IC R	AW0H	Ja / Yes	22,0	40,0	3,0	M M3,5x11 T10F	T10F	MK2A.R.6.1

Bestellbeispiel // Order example: **MK2.A.80.0050.08.04.IC R** (R = Rechte Ausführung // Right hand version)

Trägerwerkzeuge mit Connectcode „MK2.R.6.1“ sind für Individual-Schneidwerkzeuge vorgesehen.
Toolholder with Connectcode „MK2.R.6.1“ are provided for customized cutting tools.

Scheibenfräser

Aufnahme mit Keilnut.

Disc Milling Cutter

Bore with keyway.

Anzugsmoment (Schraube) // Tightening torque (screw)

3,0 Nm

Bitte Hinweise im Anhang beachten // Please read add. notes

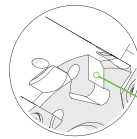
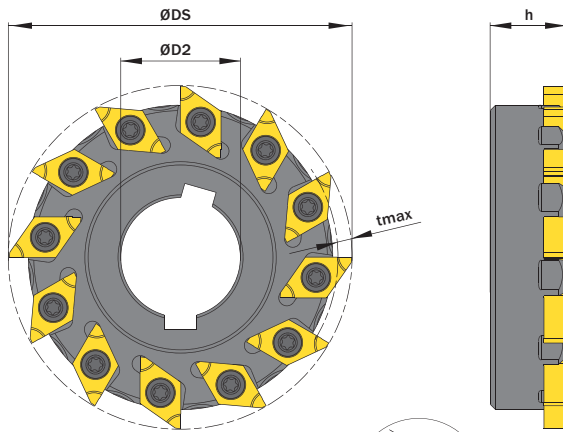
ALL (Seite/Page 645), H07 (Seite/Page 648)



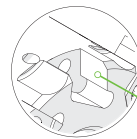
Legende
 Legend **650**



Oder besuchen Sie // Or Visit
www.simtek.info/cp/1017



Connectcode MK2A.R.4.1
 Plattensitztiefe 4,1 mm
 Depth of insert seat 4,1 mm



Connectcode MK2A.R.6.1
 Plattensitztiefe 6,1 mm. Siehe Info unten!
 Depth of insert seat 6,1 mm. See info below!

Abbildung zeigt / Drawing shows: MK2.A.81.0063.12.04 R

ØDS mm	ZEFP	Artikelnummer Part number	Webcode www.simtek.com/webcode	ØD2 mm	h mm	tmax mm	Schraube Screw	Schraubenschlüssel Screw driver	Connectcode www.simtek.com/code
63,0	12	MK2.A.81.0063.12.04 R	AWØB	22,0	14,0	3,0	M M3,5x11 T10F	T10F	MK2A.R.4.1
63,0	12	MK2.A.81.0063.12.06 R	AXWP	22,0	14,0	3,0	M M3,5x11 T10F	T10F	MK2A.R.6.1
80,0	16	MK2.A.81.0080.16.04 R	AWØC	27,0	16,0	3,0	M M3,5x11 T10F	T10F	MK2A.R.4.1
80,0	16	MK2.A.81.0080.16.06 R	AXWQ	27,0	16,0	3,0	M M3,5x11 T10F	T10F	MK2A.R.6.1
100,0	20	MK2.A.81.0100.20.04 R	AWØD	32,0	20,0	3,0	M M3,5x11 T10F	T10F	MK2A.R.4.1
100,0	20	MK2.A.81.0100.20.06 R	AXWS	32,0	20,0	3,0	M M3,5x11 T10F	T10F	MK2A.R.6.1

Bestellbeispiel // Order example: **MK2.A.81.0100.20.06 R** (R = Rechte Ausführung // Right hand version)

Trägerwerkzeuge mit Connectcode „MK2.R.6.1“ sind für Individual-Schneidwerkzeuge vorgesehen.
 Toolholder with Connectcode „MK2.R.6.1“ are provided for customized cutting tools.

Fräsen von Sicherungsringnuten

Fräsen von Sicherungsringnuten. Geeignet für alle Materialien.

Circlip Ring Groove Milling

Circlip ring groove milling. For use in all materials.

Schnittwerte (Start) // Cutting parameters (start)		
fzm	hmax	Vc
0,04 mm	0,05 mm	Seite/Page 638

Passende Klemmhalter auf Seite // Suitable toolholders on page
606, 607, 608

Bitte Hinweise im Anhang beachten // Please read add. notes
ALL (Seite/Page 645)

SP

HM

R

Legende
 Legend

650

Oder besuchen Sie // Or Visit
www.simtek.info/cp/1014

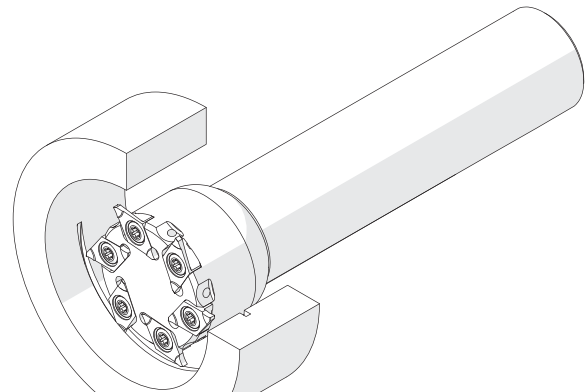
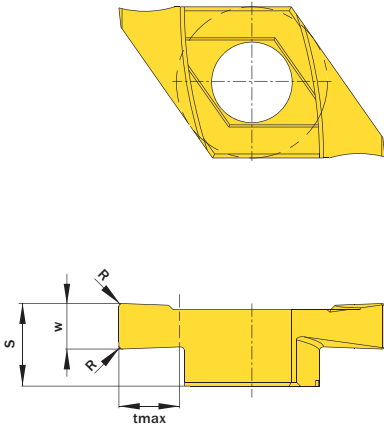


Illustration zeigt beispielhafte Anwendungsmöglichkeit mit ähnlichem Werkzeug.
 Image shows exemplary application possibility with similar tool.

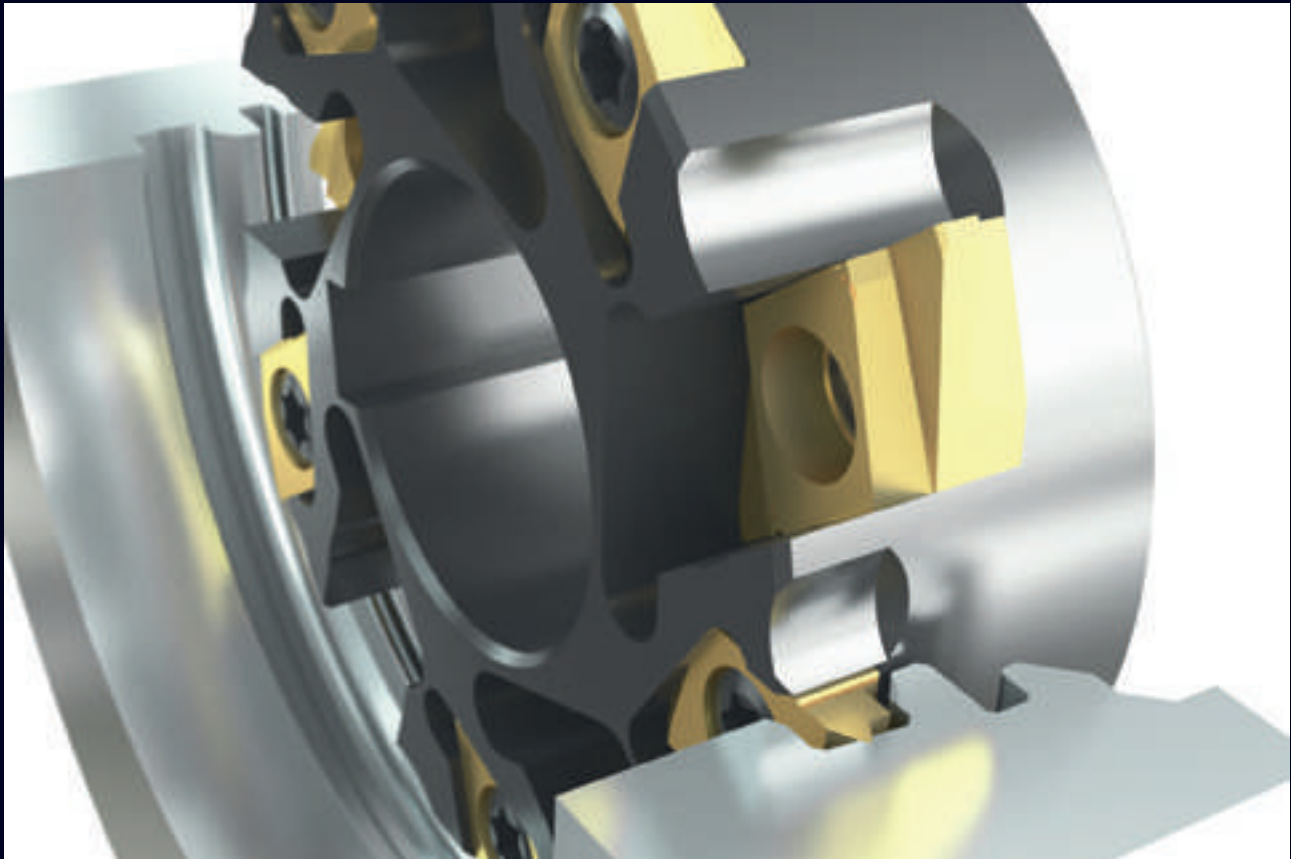
Abbildung zeigt / Drawing shows: MK2.A.0215.02 GR

w ^{-0,02}	Nennbreite Nominal width of groove	R	Artikelnummer Part number	Webcode www.simtek.com/webcode	Unsere erste Wahl Our first choice	S	tmax	Anzahl Schneiden Number of cutting edges	Connectcode www.simtek.com/ccode
mm	mm	mm			P M K N S	mm	mm		
1,24	1,1	0,1	MK2.A.0110.01 GR	AWØN	X808 HT42	4,1	3,0	2	MK2A.R.4.1 <small>upd</small>
1,44	1,3	0,1	MK2.A.0130.01 GR	AWØP	X808 HT42	4,1	3,0	2	MK2A.R.4.1 <small>upd</small>
1,74	1,6	0,1	MK2.A.0160.01 GR	AWØQ	X808 HT42	4,1	3,0	2	MK2A.R.4.1 <small>upd</small>
1,99	1,85	0,2	MK2.A.0185.02 GR	AXB6	X808 HT42	4,1	3,0	2	MK2A.R.4.1 <small>upd</small>
2,29	2,15	0,2	MK2.A.0215.02 GR	AWØS	X808 HT42	4,1	3,0	2	MK2A.R.4.1 <small>upd</small>
2,79	2,65	0,2	MK2.A.0265.02 GR	AWØT	X808 HT42	4,1	3,0	2	MK2A.R.4.1 <small>upd</small>
3,29	3,15	0,2	MK2.A.0315.02 GR	AWØU	X808 HT42	4,1	3,0	2	MK2A.R.4.1 <small>upd</small>

Bestellbeispiel // Order example: **MK2.A.0265.02 GR X808** (R = Rechte Ausführung // Right hand version, X808 = Schneidstoff // Grade)

Individualwerkzeuge // Customized tools

Kundenindividuelle Werkzeuglösungen Customer-specific tooling solutions



Perfekt aufeinander abgestimmtes Doppelfräswerkzeug mit unterschiedlich breiten Schneidwerkzeugen sowie mit präzisiertem Rund- und Planlauf dank engster Toleranzen. Dank Schneidbreiten bis zu 17,4 mm und einer kompakten Bauform können mit simmill KX vielfältigste Fräsbearbeitungen innen und außen mit hoher Zähnezahl durchgeführt werden.

SIMTEK Individualwerkzeuge bieten unzählige Vorteile! Neben unserem Anspruch, jeweils die qualitativ bestmögliche Werkzeuglösung für Ihre Anwendung anzubieten, ist es auch unser Bestreben Ihnen durch ein SIMTEK Individualwerkzeug den größtmöglichen wirtschaftlichen Nutzen zu liefern! Tausende, aktuell erfolgreich eingesetzte Individualwerkzeuge bestätigen dies!

Kontaktieren Sie uns und lassen auch Sie sich von den Vorteilen mit SIMTEK Individualwerkzeugen überzeugen!

Machining time is reduced thanks to a perfectly coordinated double milling tool. Precise radial and axial runout is ensured by tightest tolerances. Thanks to cutting edge widths of up to 17,4 mm and a compact design, simmill KX can be used for a wide variety of internal and external milling applications with a high number of teeth.

SIMTEK individual tools offer countless advantages! In addition to our goal to offer the qualitatively best possible tooling solution for your application, we also aspire to provide you with the greatest possible economic benefit from a customized SIMTEK tool! Thousands of currently successfully used SIMTEK individual tools confirm this!

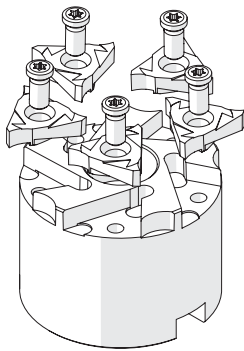
Contact us and convince yourself of the advantages of SIMTEK individual tools!

simmillKX
SIMTEK milling tools type KX

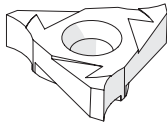
Info

Das Werkzeugsystem simmill MX The Tool System simmill MX

- + System bestehend aus Scheibenfräser,
Messerkopf oder Schafffräser
System of milling cutter shank,
milling cutter or disc milling cutter



und Wendschneidplatte mit 3 Schneiden
and three edged indexable milling insert



- + Für höchste Anforderungen
an Präzision und Stabilität
High precision and stability
- + Für Bohrungen ab \varnothing 39,0 mm
For bores as of \varnothing 39,0 mm
- + Trägerwerkzeuge mit bis zu 20 Plattensitzen
Toolholder with up to 20 insert seats

simmillMX
SIMTEK milling tools type MX



simmill AX

simmill PMX

simmill PX

simmill SX

simmill UX

simmill VX

simmill H2

simmill K2

simmill MX

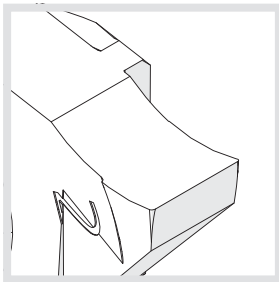
simmill OS

Index

611

Fräuserschäfte, Messerköpfe und Scheibenfräser ab Seite 613
 Milling cutter shanks, milling cutters and disc milling cutters as of page 613

Sicherungsringnuten
 Circlip ring grooves

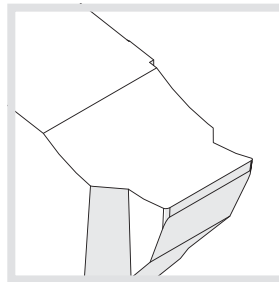


619

Ab Seite... // As of page...

Sicherungsringnuten mit
 Nutaußenkantenfasung

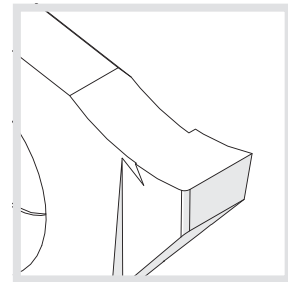
Circlip ring grooves with
 chamfering



620

Auf Seite... // On page...

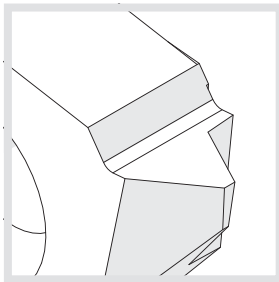
Nutfräsen allgemein
 Groove milling



627

Auf Seite... // On page...

Gewindefräsen
 Thread milling



622

Ab Seite... // As of page...

S./P. Verfügbare Gewindeprofile // Available thread profiles

- 622 Metrisches ISO-Gewinde, innen, Teilprofil
Metric ISO-thread, external, partial profile
- 623 Metrisches ISO-Gewinde, außen, Vollprofil
Metric ISO-thread, external, full profile
- 624 Metrisches ISO-Gewinde, innen, Vollprofil
Metric ISO-thread, internal, full profile
- 625 UN-Gewinde, außen, Vollprofil
UN-thread, external, full profile
- 626 UN-Gewinde, innen, Vollprofil
UN-thread, internal, full profile

Fräserschaft (DIN1835 - B25)

Weldon-Aufnahme nach DIN 1835 - B25.

Milling Cutter Shank (DIN1835 - B25)

Weldon fixation according to DIN 1835 - B25.

Anzugsmoment (Schraube) // Tightening torque (screw)

"M M5x13 T20R": 6,0 Nm
"M M5x15 T20R": 6,0 Nm

Bitte Hinweise im Anhang beachten // Please read add. notes

ALL (Seite/Page 645), H07 (Seite/Page 648)



Legende
Legend **650**



Scan
QR-Code

Oder besuchen Sie // Or Visit
www.simtek.info/cp/433

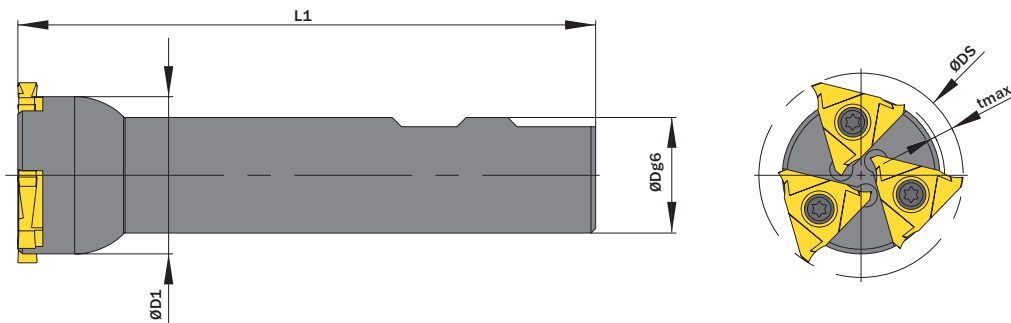


Abbildung zeigt / Drawing shows: M80.2544.03

ØDg6 mm	ØDS mm	ZEFP	Artikelnummer Part number	Webcode www.simtek.com/webcode	Mit Kühlmittelzufuhr With through coolant supply	ØD1 mm	L1 mm	tmax mm	Schraube Screw	Schraubenschlüssel Screw driver	Connectcode www.simtek.com/ccode
▼ ØDS = 39,0 mm											
25,0	39,0	2	M80.2539.02	AN3U	Nein / No	32,0	125,0	3,0	M M5x13 T20R	T20R	M14.R.6.0
25,0	39,0	2	M80.2539.02.07	AW02	Nein / No	32,0	125,0	3,0	M M5x15 T20R	T20R	M14.R.7.0
25,0	39,0	2	M80.2539.02.IC	AXE0	Ja / Yes	32,0	125,0	3,0	M M5x13 T20R	T20R	M14.R.6.0
▼ ØDS = 44,0 mm											
25,4	44,0	3	M80.1044.03.IC	A4UZ	Ja / Yes	34,0	125,0	4,0	M M5x13 T20R	T20R	M14.R.6.0 new line
25,0	44,0	3	M80.2544.03	AEPQ	Nein / No	34,0	125,0	4,0	M M5x13 T20R	T20R	M14.R.6.0
25,0	44,0	3	M80.2544.03.07	AW03	Nein / No	34,0	125,0	4,0	M M5x15 T20R	T20R	M14.R.7.0
25,0	44,0	3	M80.2544.03.IC	AXEZ	Ja / Yes	34,0	125,0	4,0	M M5x13 T20R	T20R	M14.R.6.0

Bestellbeispiel // Order example: **M80.2544.03**

simmill AX

simmill PMX

simmill PX

simmill SX

simmill UX

simmill VX

simmill H2

simmill K2

simmill MX

simmill OS

Index

Messerkopf

Fräserdorn-Aufnahme.

Milling Cutter

Milling arbor fixation.

Anzugsmoment (Schraube) // Tightening torque (screw)

"M M5x13 T20R": 6,0 Nm
"M M5x15 T20R": 6,0 Nm

Bitte Hinweise im Anhang beachten // Please read add. notes

ALL (Seite/Page 645), H07 (Seite/Page 648)



Legende
Legend **650**

Scan
QR-Code

Oder besuchen Sie // Or Visit
www.simtek.info/cp/434

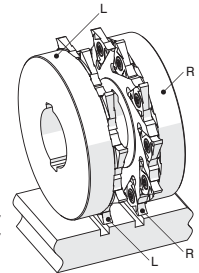
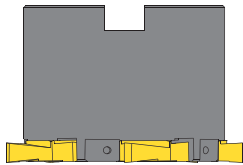
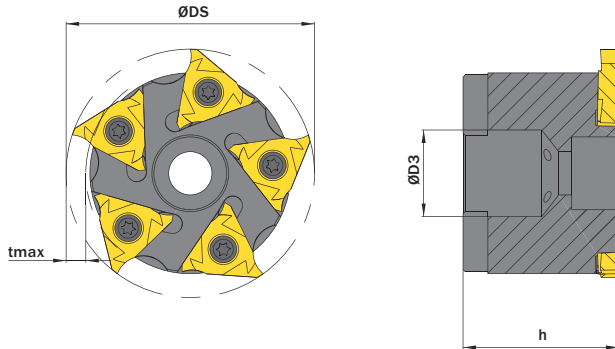


Abbildung zu Illustrationszwecken "Rechte und Linke Werkzeuge"
Image for illustration purpose of "Right and left hand tools"

Abbildung zeigt / Drawing shows: M80.0063.05.IC R

ØDS	ZEFP	Artikelnummer Part number	Webcode www.simtek.com/webcode	Mit Kühlmittelzufuhr With through coolant supply	ØD3	h	tmax	Schraube Screw	Schraubenschlüssel Screw driver	Connectcode www.simtek.com/code
mm					mm	mm	mm			
▼ ØDS = 63,0 mm										
63,0	5	M80.0063.05 R/L	R AHQX L AAKS	Nein / No	22,0	40,0	5,0	MM5x13 T20R	T20R	R M14.R.6.0 L M14.L.6.0
63,0	5	M80.0063.05.07 R/L	R AW0W L AW0V	Nein / No	22,0	40,0	5,0	MM5x15 T20R	T20R	R M14.R.7.0 L M14.L.7.0
63,0	5	M80.0063.05.07.IC R/L	R AW0Y L AW0X	Ja / Yes	22,0	40,0	5,0	MM5x15 T20R	T20R	R M14.R.7.0 L M14.L.7.0
63,0	5	M80.0063.05.IC R/L	R AUGS L AVEH	Ja / Yes	22,0	40,0	5,0	MM5x13 T20R	T20R	R M14.R.6.0 L M14.L.6.0
63,0	5	M80.2480.05 R/L	R AB23 L AW4F	Nein / No	19,05	40,0	5,0	MM5x13 T20R	T20R	R M14.R.6.0 L M14.L.6.0
63,0	5	M80.2480.05.07 R/L	R AW01 L AW4G	Nein / No	19,05	40,0	5,0	MM5x15 T20R	T20R	R M14.R.7.0 L M14.L.7.0
▼ ØDS = 80,0 mm										
80,0	8	M80.0080.08 R/L	R ADWY L AGDJ	Nein / No	27,0	32,0	5,0	MM5x13 T20R	T20R	R M14.R.6.0 L M14.L.6.0
80,0	8	M80.0080.08.07 R/L	R AW00 L AW0Z	Nein / No	27,0	32,0	5,0	MM5x15 T20R	T20R	R M14.R.7.0 L M14.L.7.0

Bestellbeispiel // Order example: **M80.0063.05 R** (R = Rechte Ausführung // Right hand version)

SIMTEK Fräserschaft nach ISO 26623

SIMTEK Trägerwerkzeug mit Polygonschaft nach ISO 26623.

SIMTEK Milling Cutter with Polygon Shank

SIMTEK toolholder with polygon shank according to ISO 26623.

Anzugsmoment (Schraube) // Tightening torque (screw)

"M M5x13 T20R": 6,0 Nm
"M M5x15 T20R": 6,0 Nm

Bitte Hinweise im Anhang beachten // Please read add. notes

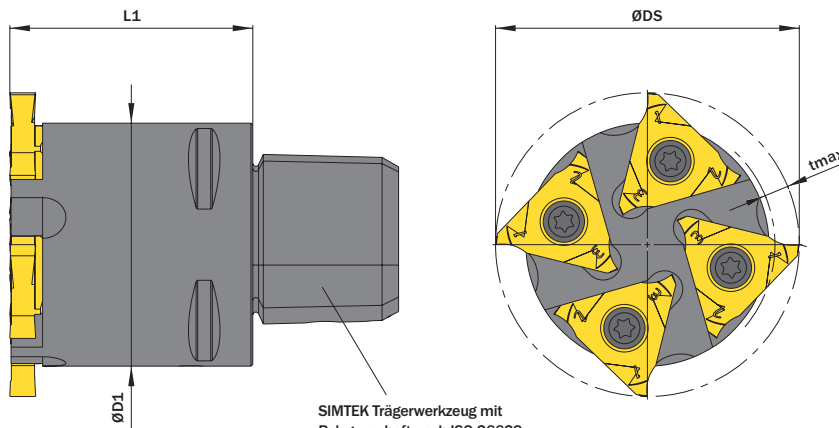
ALL (Seite/Page 645), H07 (Seite/Page 648)



Legende
Legend **650**



Oder besuchen Sie // Or Visit
www.simtek.info/cp/435



SIMTEK Trägerwerkzeug mit Polygonschaft nach ISO 26623
SIMTEK toolholder with polygon shank according to ISO 26623

Abbildung zeigt / Drawing shows: M80.C450.40.04

Polyschaftgröße Polygon shank size	ØDS	L1	ZEFP	Artikelnummer Part number	Webcode www.simtek.com/webcode	Mit Kühlmittelzufuhr With through coolant supply	ØD1	tmax	Schraube Screw	Schraubenschlüssel Screw driver	Connectcode www.simtek.com/code	
▼ ØDS = 44,0 mm												
C3	44,0	60,0	3	M80.C344.60.03	AKV4	Nein / No	34,0	4,0	M M5x13 T20R	T20R	M14.R.6.0	upd
C3	44,0	60,0	3	M80.C344.60.03.07	AW04	Nein / No	34,0	4,0	M M5x15 T20R	T20R	M14.R.7.0	upd
C3	44,0	60,0	3	M80.C344.60.03.07.IC	AYH4	Ja / Yes	34,0	4,0	M M5x15 T20R	T20R	M14.R.7.0	upd
C3	44,0	60,0	3	M80.C344.60.03.IC	AYH3	Ja / Yes	34,0	4,0	M M5x13 T20R	T20R	M14.R.6.0	upd
▼ ØDS = 50,0 mm												
C4	50,0	40,0	4	M80.C450.40.04	AD5D	Nein / No	40,0	4,0	M M5x13 T20R	T20R	M14.R.6.0	upd
C4	50,0	40,0	4	M80.C450.40.04.07	AW05	Nein / No	40,0	4,0	M M5x15 T20R	T20R	M14.R.7.0	upd
C4	50,0	40,0	4	M80.C450.40.04.07.IC	AYH6	Ja / Yes	40,0	4,0	M M5x15 T20R	T20R	M14.R.7.0	upd
C4	50,0	40,0	4	M80.C450.40.04.IC	AYH5	Ja / Yes	40,0	4,0	M M5x13 T20R	T20R	M14.R.6.0	upd
▼ ØDS = 63,0 mm												
C5	63,0	40,0	5	M80.C563.40.05	AHED	Nein / No	50,0	5,0	M M5x13 T20R	T20R	M14.R.6.0	upd
C5	63,0	40,0	5	M80.C563.40.05.07	AW06	Nein / No	50,0	5,0	M M5x15 T20R	T20R	M14.R.7.0	upd
C5	63,0	40,0	5	M80.C563.40.05.07.IC	AYJA	Ja / Yes	50,0	5,0	M M5x15 T20R	T20R	M14.R.7.0	upd
C5	63,0	40,0	5	M80.C563.40.05.IC	AYH9	Ja / Yes	50,0	5,0	M M5x13 T20R	T20R	M14.R.6.0	upd
▼ ØDS = 75,0 mm												
C6	75,0	50,0	7	M80.C675.50.07	ASAC	Nein / No	63,0	5,0	M M5x13 T20R	T20R	M14.R.6.0	upd
C6	75,0	50,0	7	M80.C675.50.07.07	AW07	Nein / No	63,0	5,0	M M5x15 T20R	T20R	M14.R.7.0	upd
C6	75,0	50,0	7	M80.C675.50.07.07.IC	AYH8	Ja / Yes	63,0	5,0	M M5x15 T20R	T20R	M14.R.7.0	upd
C6	75,0	50,0	7	M80.C675.50.07.IC	AYH7	Ja / Yes	63,0	5,0	M M5x13 T20R	T20R	M14.R.6.0	upd

Bestellbeispiel // Order example: **M80.C450.40.04**

Scheibenfräser

Aufnahme mit Keilnut.

Disc Milling Cutter

Bore with keyway.

Anzugsmoment (Schraube) // Tightening torque (screw)

6,0 Nm

Bitte Hinweise im Anhang beachten // Please read add. notes

ALL (Seite/Page 645), H07 (Seite/Page 648)



Legende
Legend **650**

Scan
QR-Code

Oder besuchen Sie // Or Visit
www.simtek.info/cp/436

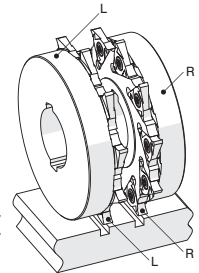
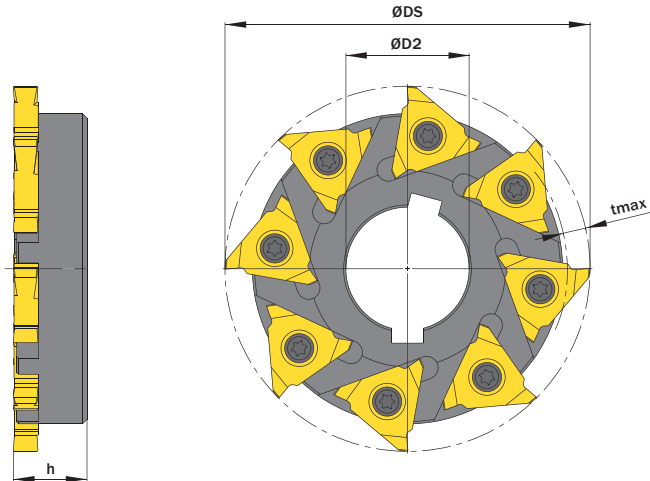


Abbildung zu Illustrationszwecken "Rechte und Linke Werkzeuge"
Image for illustration purpose of "Right and left hand tools"

Abbildung zeigt / Drawing shows: M81.0080.08 R

ØDS	ZEFP	Artikelnummer Part number	Webcode www.simtek.com/webcode	ØD2	h	tmax	Schraube Screw	Schraubenschlüssel Screw driver	Connectcode www.simtek.com/code	
									R	L
63,0	5	M81.0063.05 R/L	R AC39 L AMS2	22,0	14,0	5,0	M M5x13 T20R	T20R	R M14.R.6.0	L M14.L.6.0
80,0	8	M81.0080.08 R/L	R AJCW L ABK4	27,0	16,0	5,0	M M5x13 T20R	T20R	R M14.R.6.0	L M14.L.6.0
100,0	10	M81.0100.10 R/L	R AB7G L AFKF	32,0	20,0	5,0	M M5x13 T20R	T20R	R M14.R.6.0	L M14.L.6.0

Bestellbeispiel // Order example: **M81.0100.10 R** (R = Rechte Ausführung // Right hand version)

Trennfräser

Aufnahme mit Keilnut.

Slotting Cutter

Bore with keyway.

Anzugsmoment (Schraube) // Tightening torque (screw)

- "M M5x0,5x5 T15F": 6,0 Nm
- "M M5x10,7 T20R": 7,0 Nm
- "M M5x7,5 T20F": 7,0 Nm
- "M M5x9 T20F": 7,0 Nm

Bitte Hinweise im Anhang beachten // Please read add. notes

ALL (Seite/Page 645), H07 (Seite/Page 648)



TW Legende
ST Legend

650



Scan
 QR-Code

Oder besuchen Sie // Or Visit
www.simtek.info/cp/1128

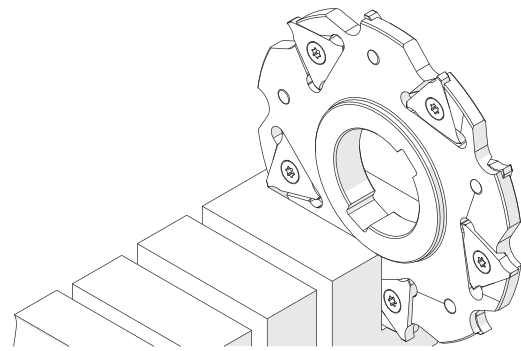
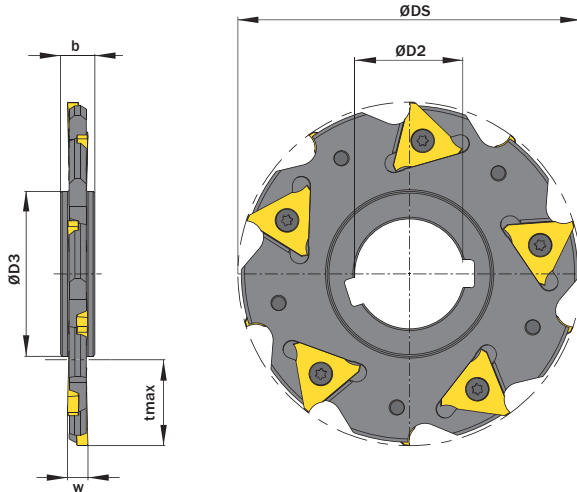


Illustration zeigt beispielhafte Anwendungsmöglichkeit mit ähnlichem Werkzeug.
 Image shows exemplary application possibility with similar tool.

Abbildung zeigt / Drawing shows: MM4.82.0100.32.06

ØDS	ØD2	w ±0,04	Artikelnummer Part number	Webcode www.simtek.com/webcode	ZEFP	b	ØD3	tmax	Schraube Screw	Schraubenschlüssel Screw driver	Connectcode www.simtek.com/code	
mm	mm	mm				mm	mm	mm				
▼ ØDS = 63,0 mm												
63,0	22,0	6,0	MM4.82.0063.22.06	AZP2	2xR + 2xL	10,0	34,0	14,0	M M5x0,5x5 T15F	T15F	MM4.82.3.2	upd
▼ ØDS = 80,0 mm												
80,0	27,0	6,0	MM4.82.0080.27.06	AYJ1	4xR + 4xL	10,0	41,0	19,0	M M5x0,5x5 T15F	T15F	MM4.82.3.2	upd
80,0	27,0	8,0	MM4.82.0080.27.08	AYJ2	4xR + 4xL	12,0	41,0	19,0	M M5x7,5 T20F	T20R	MM4.82.4.3	upd
80,0	27,0	10,0	MM4.82.0080.27.10	AYJ3	4xR + 4xL	12,0	41,0	19,0	M M5x9 T20F	T20R	MM4.82.5.4	upd
▼ ØDS = 100,0 mm												
100,0	32,0	6,0	MM4.82.0100.32.06	AYJ5	5xR + 5xL	10,0	47,0	26,0	M M5x0,5x5 T15F	T15F	MM4.82.3.2	upd
100,0	32,0	8,0	MM4.82.0100.32.08	AYJ6	5xR + 5xL	12,0	47,0	26,0	M M5x7,5 T20F	T20R	MM4.82.4.3	upd
100,0	32,0	10,0	MM4.82.0100.32.10	AYJ7	5xR + 5xL	12,0	47,0	26,0	M M5x9 T20F	T20R	MM4.82.5.4	upd
▼ ØDS = 125,0 mm												
125,0	40,0	6,0	MM4.82.0125.40.06	AYJ9	6xR + 6xL	10,0	55,0	34,5	M M5x0,5x5 T15F	T15F	MM4.82.3.2	upd
125,0	40,0	8,0	MM4.82.0125.40.08	AYKA	6xR + 6xL	12,0	55,0	34,5	M M5x7,5 T20F	T20R	MM4.82.4.3	upd
125,0	40,0	10,0	MM4.82.0125.40.10	AYKB	6xR + 6xL	14,0	55,0	34,5	M M5x9 T20F	T20R	MM4.82.5.4	upd
125,0	40,0	12,0	MM4.82.0125.40.12	AYKC	6xR + 6xL	14,0	55,0	34,5	M M5x10,7 T20R	T20R	MM4.82.6.5	upd
▼ ØDS = 160,0 mm												
160,0	40,0	6,0	MM4.82.0160.40.06	AYKD	8xR + 8xL	10,0	55,0	50,0	M M5x0,5x5 T15F	T15F	MM4.82.3.2	upd
160,0	40,0	8,0	MM4.82.0160.40.08	AYKE	8xR + 8xL	12,0	55,0	50,0	M M5x7,5 T20F	T20R	MM4.82.4.3	upd
160,0	40,0	10,0	MM4.82.0160.40.10	AYDV	8xR + 8xL	14,0	55,0	50,0	M M5x9 T20F	T20R	MM4.82.5.4	upd
160,0	40,0	12,0	MM4.82.0160.40.12	AYKF	8xR + 8xL	14,0	55,0	50,0	M M5x10,7 T20R	T20R	MM4.82.6.5	upd
▼ ØDS = 200,0 mm												
200,0	50,0	6,0	MM4.82.0200.50.06	AYKG	10xR + 10xL	10,0	69,0	65,0	M M5x0,5x5 T15F	T15F	MM4.82.3.2	upd

Bestellbeispiel // Order example: **MM4.82.0080.27.06**

simmill AX
 simmill PMX
 simmill PX
 simmill SX
 simmill UX
 simmill VX
 simmill H2
 simmill K2
 simmill MX
 simmill OS
 Index

Trennfräser

Fräserdorn-Aufnahme.

Slotting Cutter

Milling arbor fixation.

Anzugsmoment (Schraube) // Tightening torque (screw)

“M M5x0,5x5 T15F”: 6,0 Nm
 “M M5x7,5 T20R”: 6,0 Nm
 “M M5x9 T20R”: 6,0 Nm

Bitte Hinweise im Anhang beachten // Please read add. notes

ALL (Seite/Page 645), H07 (Seite/Page 648)



Legende
 Legend **650**

Scan
 QR-Code

Oder besuchen Sie // Or Visit
www.simtek.info/cp/1129

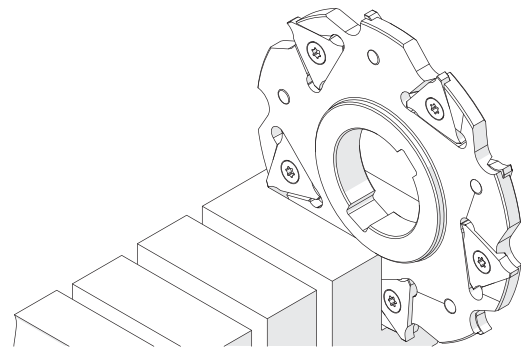
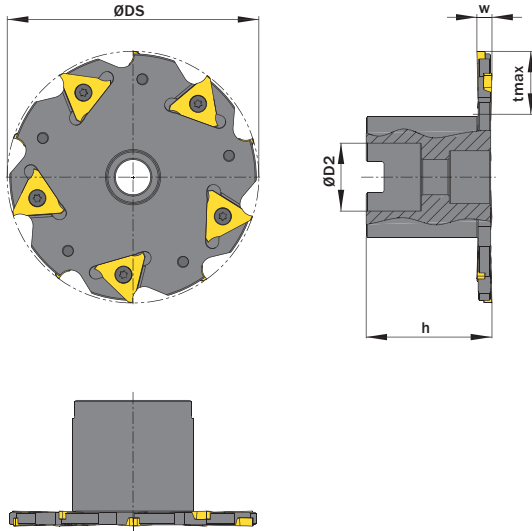


Illustration zeigt beispielhafte Anwendungsmöglichkeit mit ähnlichem Werkzeug.
 Image shows exemplary application possibility with similar tool.

Abbildung zeigt / Drawing shows: MM4.83.0100.27.06 R

ØDS	ØD2	w ±0,04	Artikelnummer Part number	Webcode www.simtek.com/webcode	ZEFP	h	tmax	Schraube Screw	Schraubenschlüssel Screw driver	Connectcode www.simtek.com/ccode
mm	mm	mm				mm	mm			
100,0	27,0	6,0	MM4.83.0100.27.06 R	AYKH	5xR + 5xL	50,0	25,0	M M5x0,5x5 T15F	T15F	MM4.82.3.2
100,0	27,0	8,0	MM4.83.0100.27.08 R	AYKJ	5xR + 5xL	50,0	25,0	M M5x7,5 T20R	T20R	MM4.82.4.3
100,0	27,0	10,0	MM4.83.0100.27.10 R	AYKK	5xR + 5xL	50,0	25,0	M M5x9 T20R	T20R	MM4.82.5.4

Bestellbeispiel // Order example: **MM4.83.0100.27.10 R** (R = Rechte Ausführung // Right hand version)

Fräsen von Sicherungsringnuten

Fräsen von Sicherungsringnuten. Geeignet für alle Materialien.

Circlip Ring Groove Milling

Circlip ring groove milling. For use in all materials.

Schnittwerte (Start) // Cutting parameters (start)		
fzm 0,04 mm	hmax 0,05 mm	Vc Seite/Page 638

Passende Klemmhalter auf Seite // Suitable toolholders on page
613, 614, 615, 616

Bitte Hinweise im Anhang beachten // Please read add. notes
ALL (Seite/Page 645)

SP

HM

R

Scan
QR-Code

Legende
Legend **650**

Oder besuchen Sie // Or Visit
www.simtek.info/cp/438

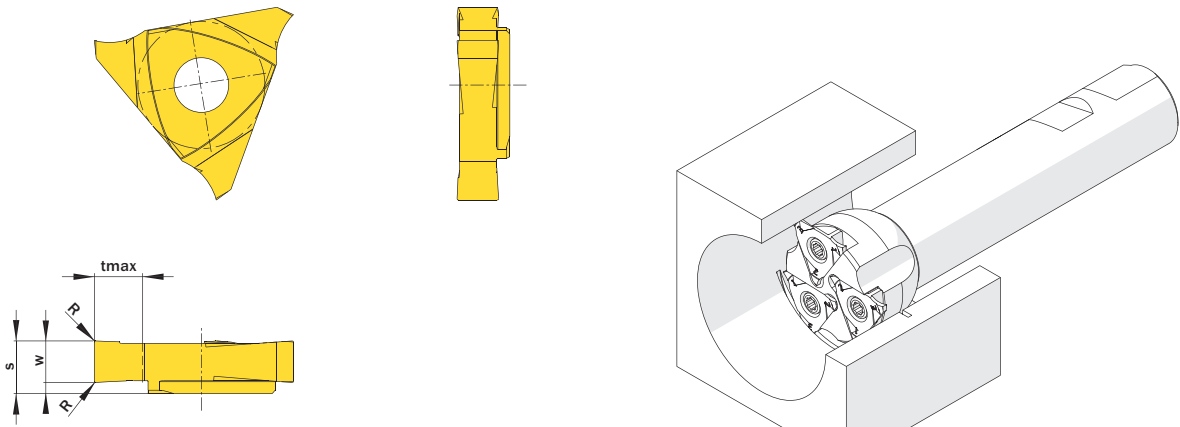


Illustration zeigt beispielhafte Anwendungsmöglichkeit mit ähnlichem Werkzeug.
Image shows exemplary application possibility with similar tool.

Abbildung zeigt / Drawing shows: M14.0415.02 GR

w ^{-0,02} mm	Nennbreite Nominal width of groove mm	R mm	Artikelnummer Part number	Webcode www.simtek.com/webcode	Unsere erste Wahl Our first choice					S mm	tmax mm	Anzahl Schneiden Number of cutting edges	Connectcode www.simtek.com/code	
					P	M	K	N	S				R	L
1,17	-	0,1	M14.0117.01 GR/L	R AMF9 L AW4J	X800	GT42	5,4	5,0	3	R M14.R.6.0 L M14.L.6.0	inch	upd		
1,44	1,3	0,1	M14.0130.01 GR/L	R AMMX L AKWB	X800	GT42	5,4	5,0	3	R M14.R.6.0 L M14.L.6.0	inch	upd		
1,57	-	0,1	M14.0157.01 GR/L	R AN5A L AW4K	X800	GT42	5,4	5,0	3	R M14.R.6.0 L M14.L.6.0	inch	upd		
1,74	1,6	0,1	M14.0160.01 GR/L	R AJE8 L ANFM	X800	GT42	5,4	5,0	3	R M14.R.6.0 L M14.L.6.0	inch	upd		
1,99	1,85	0,2	M14.0185.02 GR/L	R AMGV L ABUJ	X800	GT42	5,4	5,0	3	R M14.R.6.0 L M14.L.6.0	inch	upd		
2,0	-	0,2	M14.0200.02 GR/L	R AYQ8 L AYQ9	X800	GT42	5,4	5,0	3	R M14.R.6.0 L M14.L.6.0	inch	upd		
2,29	2,15	0,2	M14.0215.02 GR/L	R ADKS L ANZX	X800	GT42	5,4	5,0	3	R M14.R.6.0 L M14.L.6.0	inch	upd		
2,39	-	0,2	M14.0239.02 GR/L	R AJNN L AW4M	X800	GT42	5,4	5,0	3	R M14.R.6.0 L M14.L.6.0	inch	upd		
2,5	-	0,2	M14.0250.02 GR/L	R AYSB L AYSA	X800	GT42	5,4	5,0	3	R M14.R.6.0 L M14.L.6.0	inch	upd		
2,79	2,65	0,2	M14.0265.02 GR/L	R AENW L ANYU	X800	GT42	5,4	5,0	3	R M14.R.6.0 L M14.L.6.0	inch	upd		
3,0	-	0,2	M14.0300.02 GR/L	R AYSC L AYSD	X800	GT42	5,4	5,0	3	R M14.R.6.0 L M14.L.6.0	inch	upd		
3,29	3,15	0,2	M14.0315.02 GR/L	R AA0V L AEJW	X800	GT42	5,4	5,0	3	R M14.R.6.0 L M14.L.6.0	inch	upd		
3,18	-	0,2	M14.0318.02 GR/L	R ANFA L AW4N	X800	GT42	5,4	5,0	3	R M14.R.6.0 L M14.L.6.0	inch	upd		
3,5	-	0,2	M14.0350.02 GR/L	R AYSF L AYSE	X800	GT42	5,4	5,0	3	R M14.R.6.0 L M14.L.6.0	inch	upd		
4,0	-	0,2	M14.0400.02 GR/L	R AGDU L AW4P	X800	GT42	5,4	5,0	3	R M14.R.6.0 L M14.L.6.0	inch	upd		
4,29	4,15	0,2	M14.0415.02 GR/L	R APFY L AJG2	X800	GT42	5,4	5,0	3	R M14.R.6.0 L M14.L.6.0	inch	upd		
4,37	-	0,2	M14.0437.02 GR/L	R AGN0 L AW4H	X800	GT42	5,4	5,0	3	R M14.R.6.0 L M14.L.6.0	inch	upd		
4,75	-	0,2	M14.0475.02 GR/L	R AKXF L AW4Q	X800	GT42	5,4	5,0	3	R M14.R.6.0 L M14.L.6.0	inch	upd		
5,0	-	0,2	M14.0500.02 GR	A26Z	X800	GT42	5,4	5,0	3	M14.R.6.0	new	upd		
5,29	5,15	0,2	M14.0515.02 GR/L	R ADWD L AGAK	X800	GT42	5,4	5,0	3	R M14.R.6.0 L M14.L.6.0	inch	upd		

Bestellbeispiel // Order example: M14.0215.02 GR X800 (R = Rechte Ausführung // Right hand version, X800 = Schneidstoff // Grade)

Fräsen von Sicherungsringnuten mit Fassung

Fräsen von Sicherungsringnuten mit Nutaußenkantenfasung. Geeignet für alle Materialien.

Circlip Ring Groove Milling with chamfering

Circlip ring groove milling with chamfering. For use in all materials.

Schnittwerte (Start) // Cutting parameters (start)		
fzm 0,04 mm	hmax 0,05 mm	Vc Seite/Page 638

Passende Klemmhalter auf Seite // Suitable toolholders on page
613, 614, 615, 616

Bitte Hinweise im Anhang beachten // Please read add. notes
ALL (Seite/Page 645)

SP

HM

R

Legende
Legend **650**

Scan
QR-Code

Oder besuchen Sie // Or Visit
www.simtek.info/cp/440

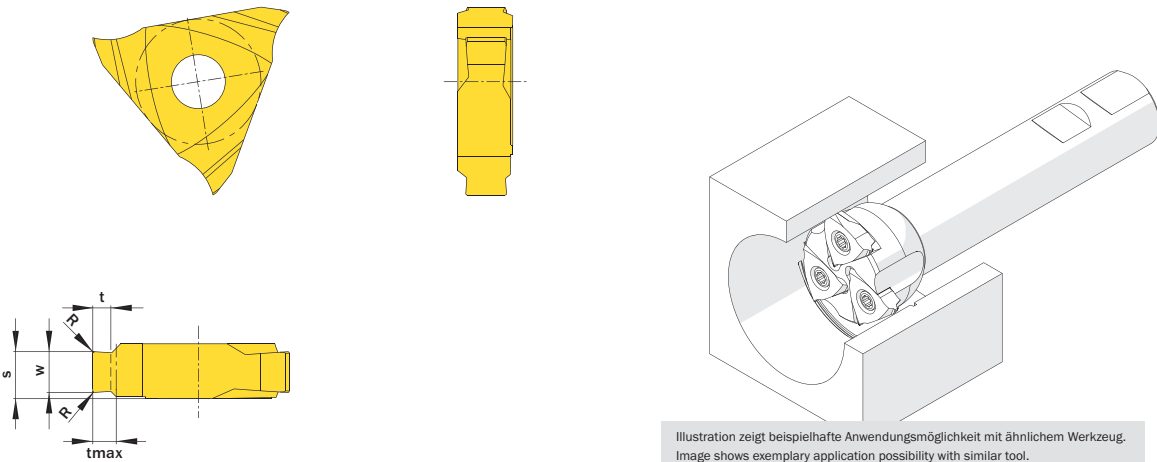


Illustration zeigt beispielhafte Anwendungsmöglichkeit mit ähnlichem Werkzeug.
Image shows exemplary application possibility with similar tool.

Abbildung zeigt / Drawing shows: M14.4120.54 FR

Nennbreite Nominal width of groove	tmax	Artikelnummer Part number	Webcode www.simtek.com/webcode	Unsere erste Wahl Our first choice		R	S	t	w ^{-0,02}	Anzahl Schneiden Number of cutting edges	Connectcode www.simtek.com/code	
				P	M						K	N
1,1	0,5	M14.1105.54 FR/L	R AJ5S L AMX4	X800	GT42	0,1	4,4	0,49	1,24	3	R M14.R.6.0	L M14.L.6.0
1,3	0,7	M14.1307.54 FR/L	R AN4Y L ABTB	X800	GT42	0,1	4,5	0,67	1,44	3	R M14.R.6.0	L M14.L.6.0
1,3	0,85	M14.1308.54 FR/L	R AHBN L AMØJ	X800	GT42	0,1	4,5	0,83	1,44	3	R M14.R.6.0	L M14.L.6.0
1,6	0,85	M14.1609.54 FR/L	R ABX1 L AJWH	X800	GT42	0,15	4,4	0,83	1,74	3	R M14.R.6.0	L M14.L.6.0
1,6	1,0	M14.1610.54 FR/L	R AKFG L AGZK	X800	GT42	0,15	4,4	0,97	1,74	3	R M14.R.6.0	L M14.L.6.0
1,85	1,25	M14.1812.54 FR/L	R AC89 L AAGW	X800	GT42	0,15	4,5	1,23	1,99	3	R M14.R.6.0	L M14.L.6.0
2,15	1,5	M14.2115.54 FR/L	R AMBF L AHMT	X800	GT42	0,15	4,7	1,47	2,29	3	R M14.R.6.0	L M14.L.6.0
2,65	1,5	M14.2616.54 FR/L	R ACAP L AFDE	X800	GT42	0,15	4,4	1,47	2,79	3	R M14.R.6.0	L M14.L.6.0
2,65	1,75	M14.2617.54 FR/L	R AFD5 L AGYX	X800	GT42	0,15	4,4	1,72	2,79	3	R M14.R.6.0	L M14.L.6.0
3,15	1,75	M14.3118.54 FR/L	R AF4S L APH2	X800	GT42	0,15	4,7	1,72	3,29	3	R M14.R.6.0	L M14.L.6.0
4,15	2,0	M14.4120.54 FR/L	R AKFU L ABZH	X800	GT42	0,15	4,9	1,97	4,29	3	R M14.R.6.0	L M14.L.6.0
4,15	2,5	M14.4125.54 FR/L	R AAXY L AC9D	X800	GT42	0,15	4,9	2,47	4,29	3	R M14.R.6.0	L M14.L.6.0
5,15	3,0	M14.5130.61 FR/L	R ABXB L ANC8	X800	GT42	0,15	5,8	2,97	5,29	3	R M14.R.6.0	L M14.L.6.0

Bestellbeispiel // Order example: **M14.2617.54 FR X800** (R = Rechte Ausführung // Right hand version, X800 = Schneidstoff // Grade)

Fräsen von Vollradiusnuten

Nutfräsen runder Nutformen.

Full Radius Groove Milling

Full radius groove milling.

Schnittwerte (Start) // Cutting parameters (start)		
fzm 0,04 mm	hmax 0,05 mm	Vc Seite/Page 638

Passende Klemmhalter auf Seite // Suitable toolholders on page
613, 614, 615, 616

Bitte Hinweise im Anhang beachten // Please read add. notes
ALL (Seite/Page 645)

SP
HM

R

Legende
Legend **650**

Scan
QR-Code Oder besuchen Sie // Or Visit
www.simtek.info/cp/984

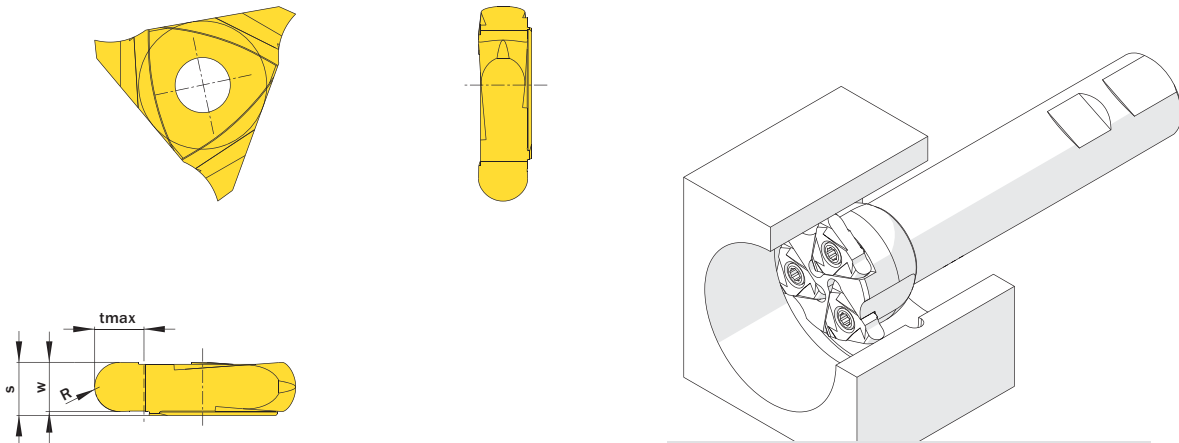


Illustration zeigt beispielhafte Anwendungsmöglichkeit mit ähnlichem Werkzeug.
Image shows exemplary application possibility with similar tool.

Abbildung zeigt / Drawing shows: M14.0500.250 VR

w	R	Artikelnummer Part number	Webcode www.simtek.com/webcode	Unsere erste Wahl Our first choice	S	tmax	Anzahl Schneiden Number of cutting edges	Connectcode www.simtek.com/code
mm	mm			P M K N S	mm	mm		
2,5	1,25	M14.0250.125 VR	A2UN	X800 GT42	5,4	5,0	3	M14.R.6.0
3,0	1,5	M14.0300.150 VR	AP15	X800 GT42	5,4	5,0	3	M14.R.6.0
4,0	2,0	M14.0400.200 VR	ABPU	X800 GT42	5,4	5,0	3	M14.R.6.0
5,0	2,5	M14.0500.250 VR	AJ3G	X800 GT42	5,4	5,0	3	M14.R.6.0

Bestellbeispiel // Order example: **M14.0500.250 VR X800** (R = Rechte Ausführung // Right hand version, X800 = Schneidstoff // Grade)

simmill AX

simmill PMX

simmill PX

simmill SX

simmill UX

simmill VX

simmill H2

simmill K2

simmill MX

simmill OS

Index

Metrisches ISO-Gewindefräsen, Teilprofil, Innen

Ausgelegt als Mehrbereichswerkzeuge. Die angegebene „Steigung (von)“ ist normgerecht. Die „Steigung (bis)“ kann ebenfalls realisiert werden. Vgl. Hinweistexte.

Thread milling, metric ISO-Thread, partial profile, Internal

Multi-purpose milling inserts. The given „Pitch (as of)“ is conforming to standards. The „Pitch (up to)“ is possible too at the expense of conformity. Please read additional notes.

Schnittwerte (Start) // Cutting parameters (start)		
fzm 0,04 mm	hmax 0,05 mm	Vc Seite/Page 638

Passende Klemmhalter auf Seite // Suitable toolholders on page
613, 614, 615, 616

Bitte Hinweise im Anhang beachten // Please read add. notes
ALL (Seite/Page 645), H03 (Seite/Page 648)

SP
HM
R
 Legende Legend **650**
 Scan QR-Code Oder besuchen Sie // Or Visit www.simtek.info/cp/441

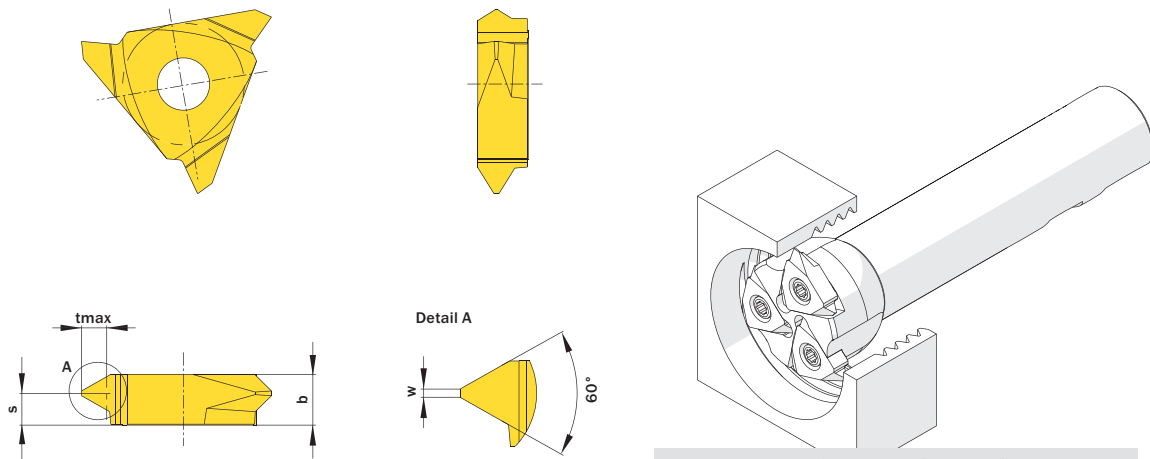


Illustration zeigt beispielhafte Anwendungsmöglichkeit mit ähnlichem Werkzeug. Image shows exemplary application possibility with similar tool.

Abbildung zeigt / Drawing shows: M14.2445.01 MR

Steigung (von) Pitch (as of)	Steigung (bis) Pitch (up to)	Artikelnummer Part number	Webcode www.simtek.com/webcode	Unsere erste Wahl Our first choice	b	S	w	tmax	Anzahl Schneiden Number of cutting edges	Connectcode www.simtek.com/code
mm	mm			P M K N S	mm	mm	mm	mm		
1,5	1,5	M14.0815.01 MR/L	R AD3Z L AFKH	X800 GT42	5,4	4,6	0,19	0,81	3	R M14.R.6.0 L M14.L.6.0
2,0	2,0	M14.1020.01 MR/L	R AJBD L AFJJ	X800 GT42	5,4	4,4	0,25	1,08	3	R M14.R.6.0 L M14.L.6.0
1,5	3,5	M14.1535.01 MR/L	R AACV L ADSD	X800 GT42	5,4	3,9	0,18	1,89	3	R M14.R.6.0 L M14.L.6.0
3,5	4,0	M14.2140.01 MR/L	R AN7M L AKFW	X800 GT42	5,4	3,7	0,43	2,17	3	R M14.R.6.0 L M14.L.6.0
3,75	4,5	M14.2445.01 MR/L	R ANUB L AA3A	X800 GT42	5,4	3,4	0,47	2,44	3	R M14.R.6.0 L M14.L.6.0
4,0	5,0	M14.2750.01 MR/L	R AKBJ L AGFP	X800 GT42	5,4	3,4	0,5	2,7	3	R M14.R.6.0 L M14.L.6.0
4,5	6,0	M14.3260.01 MR/L	R AJ8M L AGUP	X800 GT42	5,4	3,0	0,56	3,25	3	R M14.R.6.0 L M14.L.6.0
3,5	6,0	M14.4060.01 MR/L	R AMA7 L ACPD	X800 GT42	5,25	2,6	0,44	3,65	3	R M14.R.6.0 L M14.L.6.0

Bestellbeispiel // Order example: **M14.4060.01 MR X800** (R = Rechte Ausführung // Right hand version, X800 = Schneidstoff // Grade)

Bitte beachten Sie die zusätzlichen Hinweise zu den Mehrbereichswerkzeugen im Infobereich rechts oben.
 Please read the additional notes mentioned in the information area on the top right corner of this page.

Metrisches ISO-Gewindefräsen, Vollprofil, Außen

Fräsen von metrischen ISO-Gewinden, Vollprofil.

Thread milling, metric ISO-Thread,
External, full profile

Thread milling of metric ISO-thread, full profile.

Schnittwerte (Start) // Cutting parameters (start)		
fzm 0,04 mm	hmax 0,05 mm	Vc Seite/Page 638

Passende Klemmhalter auf Seite // Suitable toolholders on page
613, 614, 615, 616

Bitte Hinweise im Anhang beachten // Please read add. notes
ALL (Seite/Page 645), H06 (Seite/Page 648)

SP

HM

R

●

Legende
Legend **650**

Scan
QR-Code

Oder besuchen Sie // Or Visit
www.simtek.info/cp/451

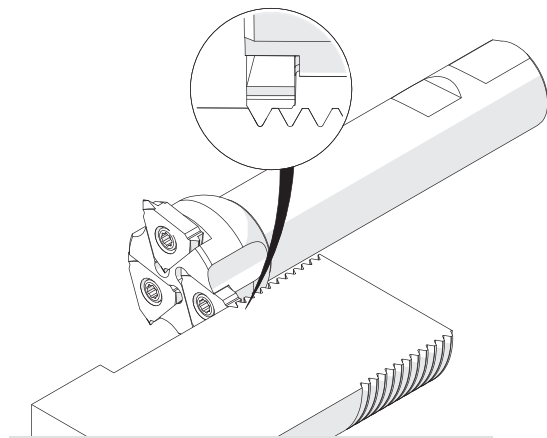
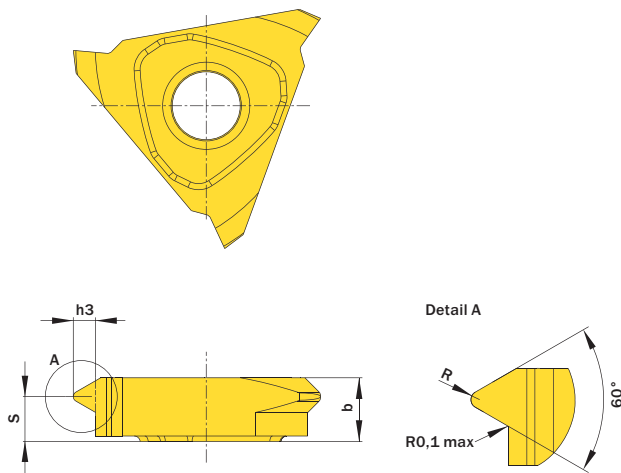


Illustration zeigt beispielhafte Anwendungsmöglichkeit mit ähnlichem Werkzeug.
Image shows exemplary application possibility with similar tool.

Abbildung zeigt / Drawing shows: M14.MT30.02 EM R

Steigung (von) Pitch (as of)	Artikelnummer Part number	Webcode www.simtek.com/webcode	Unsere erste Wahl Our first choice		R	h3	b	S	Anzahl Schneiden Number of cutting edges	Connectcode www.simtek.com/code
			P	MKN						
1.5	M14.MT15.02 EM R	AQ6A	X800	G742	0,22	0,92	5,25	4,4	3	M14.R.6.0
2.0	M14.MT20.02 EM R	AQ6C	X800	G742	0,29	1,23	5,25	4,2	3	M14.R.6.0
2.5	M14.MT25.02 EM R	AT90	X800	G742	0,36	1,53	5,25	3,9	3	M14.R.6.0
3.0	M14.MT30.02 EM R	AQ6E	X800	G742	0,43	1,84	5,25	3,7	3	M14.R.6.0
3.5	M14.MT35.02 EM R	ASZ5	X800	G742	0,52	2,15	5,25	3,5	3	M14.R.6.0
4.0	M14.MT40.02 EM R	AQ6G	X800	G742	0,58	2,45	5,25	3,3	3	M14.R.6.0
4.5	M14.MT45.02 EM R	AS0A	X800	G742	0,65	2,76	5,25	3,1	3	M14.R.6.0
5.0	M14.MT50.02 EM R	AQ6K	X800	G742	0,72	3,06	5,85	3,4	3	M14.R.6.0
5.5	M14.MT55.02 EM R	AS0B	X800	G742	0,78	3,37	7,6	4,8	3	M14.R.7.0
6.0	M14.MT60.02 EM R	AS0C	X800	G742	0,87	3,68	7,6	4,6	3	M14.R.7.0

Bestellbeispiel // Order example: **M14.MT50.02 EM R X800** (R = Rechte Ausführung // Right hand version, X800 = Schneidstoff // Grade)

Mehr Infos zu den **Mehrbereichswerkzeugen** und deren **GewindegröÙeneignung** finden Sie auf Seite 649

More information about the **multi-purpose thread milling tools** and the **thread size suitability** can be found on page 649

Metrisches ISO-Gewindefräsen, Vollprofil, innen

Fräsen von metrischen ISO-Gewinden, Vollprofil.

Thread milling, metric ISO-Thread, internal, full profile

Thread milling of metric ISO-thread, full profile.

Schnittwerte (Start) // Cutting parameters (start)		
fzm 0,04 mm	hmax 0,05 mm	Vc Seite/Page 638

Passende Klemmhalter auf Seite // Suitable toolholders on page
613, 614, 615, 616

Bitte Hinweise im Anhang beachten // Please read add. notes
ALL (Seite/Page 645), H06 (Seite/Page 648)

SP
HM

R

●

Legende
Legend **650**

Scan
QR-Code

Oder besuchen Sie // Or Visit
www.simtek.info/cp/936

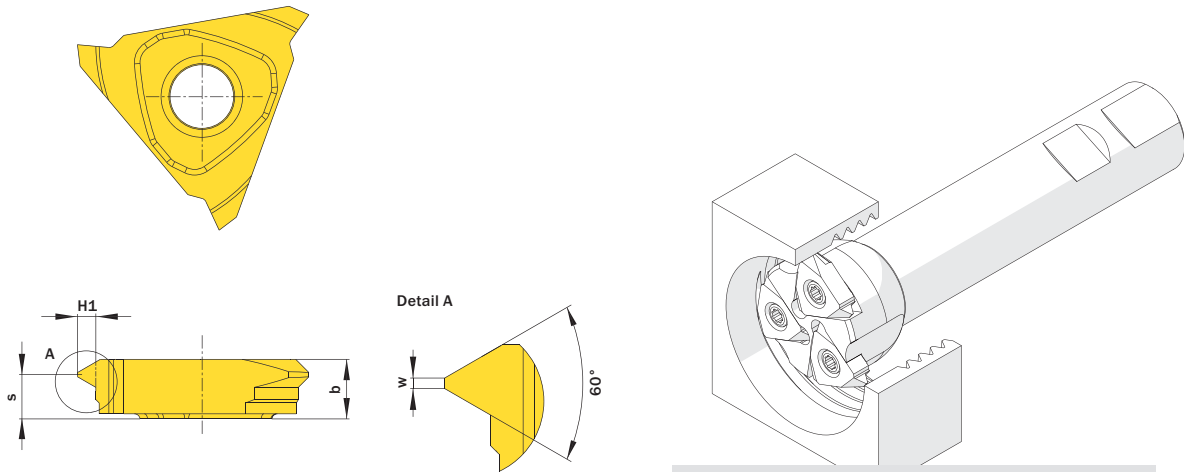


Illustration zeigt beispielhafte Anwendungsmöglichkeit mit ähnlichem Werkzeug.
Image shows exemplary application possibility with similar tool.

Abbildung zeigt / Drawing shows: M14.MT30.02 IM R

Steigung (von) Pitch (as of)	Artikelnummer Part number	Webcode www.simtek.com/webcode	Unsere erste Wahl Our first choice		H1	b	S	w	Anzahl Schneiden Number of cutting edges	Connectcode www.simtek.com/code
			P	MKN						
1,5	M14.MT15.02 IM R	AT6J	X800	G742	0,81	5,25	4,4	0,19	3	M14.R.6.0
2,0	M14.MT20.02 IM R	AT6K	X800	G742	1,08	5,25	4,2	0,25	3	M14.R.6.0
3,0	M14.MT30.02 IM R	AT6M	X800	G742	1,62	5,25	3,9	0,38	3	M14.R.6.0
3,5	M14.MT35.02 IM R	AT6N	X800	G742	1,89	5,25	3,7	0,44	3	M14.R.6.0
4,0	M14.MT40.02 IM R	AT6P	X800	G742	2,17	5,35	3,5	0,5	3	M14.R.6.0
4,5	M14.MT45.02 IM R	AT6Q	X800	G742	2,44	5,25	3,3	0,56	3	M14.R.6.0
5,0	M14.MT50.02 IM R	AT6S	X800	G742	2,71	5,85	3,8	0,62	3	M14.R.6.0
5,5	M14.MT55.02 IM R	AT6T	X800	G742	2,98	5,85	3,6	0,69	3	M14.R.6.0
6,0	M14.MT60.02 IM R	AT6U	X800	G742	3,25	7,6	5,2	0,75	3	M14.R.7.0

Bestellbeispiel // Order example: **M14.MT60.02 IM R X800** (R = Rechte Ausführung // Right hand version, X800 = Schneidstoff // Grade)

UN-Gewindefräsen, Vollprofil, Außenbearbeitung

Fräsen von UN-Gewinden, Vollprofil, für Außenbearbeitung.

Thread milling, External applications,
UN Full Profile

Thread milling of UN-threads, full profile, for external application.

Schnittwerte (Start) // Cutting parameters (start)		
fzm 0,04 mm	hmax 0,05 mm	Vc Seite/Page 638

Passende Klemmhalter auf Seite // Suitable toolholders on page
613, 614, 615, 616

Bitte Hinweise im Anhang beachten // Please read add. notes
ALL (Seite/Page 645)

SP
HM

R

Legende
Legend

650

Scan QR-Code Oder besuchen Sie // Or Visit
www.simtek.info/cp/875

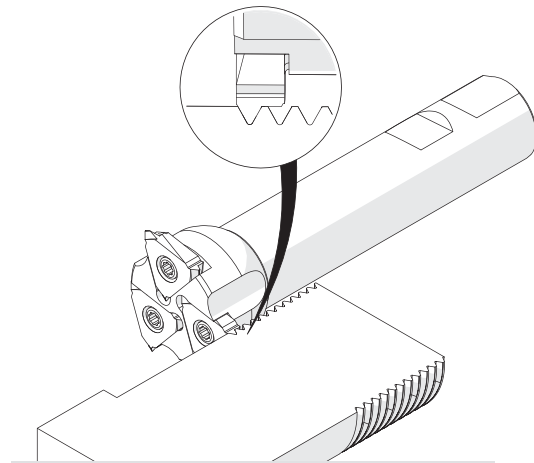
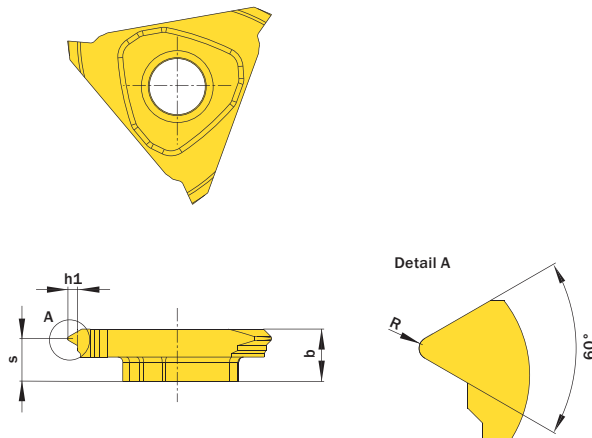


Illustration zeigt beispielhafte Anwendungsmöglichkeit mit ähnlichem Werkzeug.
Image shows exemplary application possibility with similar tool.

Abbildung zeigt / Drawing shows: M14.UN16.02 MR

Gang/Zoll Threads/Inch	Artikelnummer Part number	Webcode www.simtek.com/webcode	Unsere erste Wahl Our first choice		b	h1	R	S	Anzahl Schneiden Number of cutting edges	Connectcode www.simtek.com/code
			PM	MKN						
4	M14.UN04.02 MR	AS0F	X800	G742	7,6	3,9	0,92	4,4	3	M14.R.7.0
6	M14.UN06.02 MR	AS0E	X800	G742	7,6	2,6	0,61	5,3	3	M14.R.7.0
8	M14.UN08.02 MR	AS0D	X800	G742	5,15	1,95	0,46	3,4	3	M14.R.6.0
10	M14.UN10.02 MR	AS1D	X800	G742	5,15	1,56	0,37	3,6	3	M14.R.6.0
11	M14.UN11.02 MR	AS1C	X800	G742	5,15	1,416	0,33	3,9	3	M14.R.6.0
12	M14.UN12.02 MR	AS1B	X800	G742	5,15	1,3	0,3	3,9	3	M14.R.6.0
14	M14.UN14.02 MR	AS1A	X800	G742	5,15	1,11	0,26	4,0	3	M14.R.6.0
16	M14.UN16.02 MR	AS09	X800	G742	5,15	0,974	0,23	4,0	3	M14.R.6.0
18	M14.UN18.02 MR	AS08	X800	G742	5,15	0,87	0,2	4,2	3	M14.R.6.0
20	M14.UN20.02 MR	ASZ8	X800	G742	5,15	0,78	0,18	4,2	3	M14.R.6.0

Bestellbeispiel // Order example: **M14.UN08.02 MR X800** (R = Rechte Ausführung // Right hand version, X800 = Schneidstoff // Grade)

simmill AX
simmill PMX
simmill PX
simmill SX
simmill UX
simmill VX
simmill H2
simmill K2
simmill MX
simmill OS
Index

UN-Gewindefräsen, Vollprofil, Innenbearbeitung

Fräsen von UN-Gewinden, Vollprofil, für Innenbearbeitung.

Thread milling,
 Internal applications, UN Full Profile

Thread milling of UN-threads, full profile, for internal application.

Schnittwerte (Start) // Cutting parameters (start)		
fzm 0,04 mm	hmax 0,05 mm	Vc Seite/Page 638

Passende Klemmhalter auf Seite // Suitable toolholders on page
613, 614, 615, 616

Bitte Hinweise im Anhang beachten // Please read add. notes
ALL (Seite/Page 645)

SP
HM

R

●

Legende
 Legend **650**

Scan
 QR-Code

Oder besuchen Sie // Or Visit
www.simtek.info/cp/937

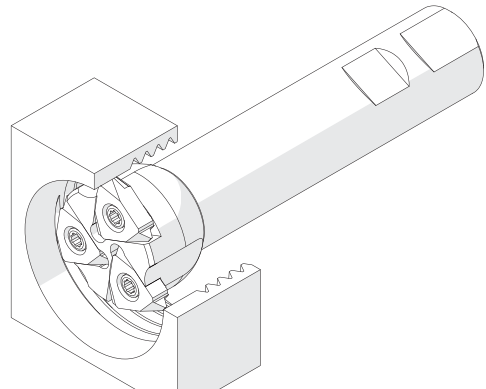
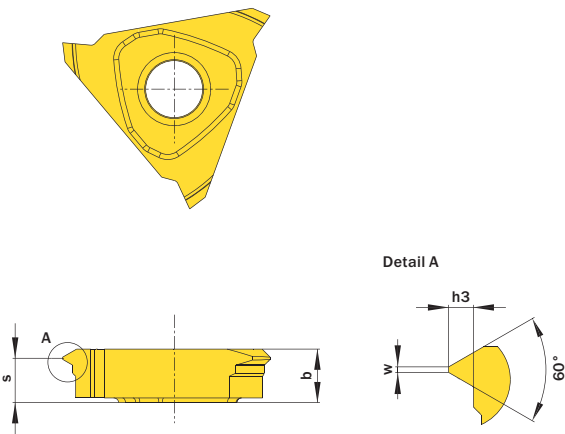


Illustration zeigt beispielhafte Anwendungsmöglichkeit mit ähnlichem Werkzeug.
 Image shows exemplary application possibility with similar tool.

Abbildung zeigt / Drawing shows: M14.UN14.02 IM R

Gang/Zoll Threads/Inch	Artikelnummer Part number	Webcode www.simtek.com/webcode	Unsere erste Wahl Our first choice		h3	b	S	w	Anzahl Schneiden Number of cutting edges	Connectcode www.simtek.com/code
			P	MKN S						
4	M14.UN04.02 IM R	AT7A	X800	G742	3,44	7,6	5,0	0,79	3	M14.R.7.0
6	M14.UN06.02 IM R	AT7B	X800	G742	2,29	5,25	3,4	0,52	3	M14.R.6.0
8	M14.UN08.02 IM R	AT7C	X800	G742	1,72	5,45	3,8	0,39	3	M14.R.6.0
10	M14.UN10.02 IM R	AT7D	X800	G742	1,37	5,25	4,1	0,32	3	M14.R.6.0
11	M14.UN11.02 IM R	AT7E	X800	G742	1,25	5,25	4,2	0,29	3	M14.R.6.0
12	M14.UN12.02 IM R	AT7F	X800	G742	1,15	5,25	4,2	0,26	3	M14.R.6.0
14	M14.UN14.02 IM R	AT7G	X800	G742	0,98	5,25	4,4	0,22	3	M14.R.6.0
16	M14.UN16.02 IM R	AT7H	X800	G742	0,86	5,25	4,4	0,19	3	M14.R.6.0
18	M14.UN18.02 IM R	AT7J	X800	G742	0,76	5,25	4,5	0,17	3	M14.R.6.0
20	M14.UN20.02 IM R	AT7K	X800	G742	0,69	5,25	4,6	0,15	3	M14.R.6.0

Bestellbeispiel // Order example: **M14.UN12.02 IM R X800** (R = Rechte Ausführung // Right hand version, X800 = Schneidstoff // Grade)

Allgemeines Nutfräsen

Nutfräsen gerader Nutformen. Geeignet für alle Materialien.

General groove milling

General groove milling. For use in all materials.

Passende Klemmhalter auf Seite // Suitable toolholders on page
617, 618

Bitte Hinweise im Anhang beachten // Please read add. notes
ALL (Seite/Page 645)



Legende
 Legend **650**

Scan QR-Code Oder besuchen Sie // Or Visit
www.simtek.info/cp/1130

Passende Scheibenfräser finden Sie auf den Seiten 617 und 618
 Compatible milling cutters can be found on pages 617 and 618

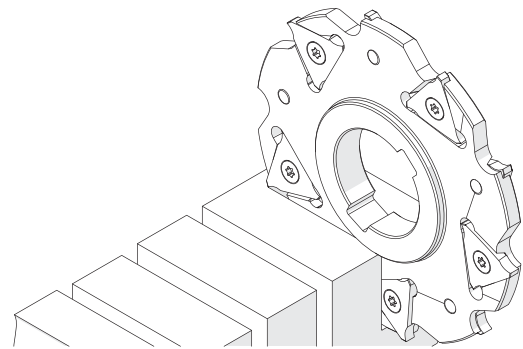
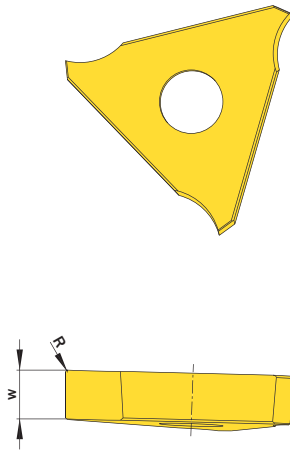


Illustration zeigt beispielhafte Anwendungsmöglichkeit mit ähnlichem Werkzeug.
 Image shows exemplary application possibility with similar tool.

Abbildung zeigt / Drawing shows: MM4.08.0430.02 GR

w ^{+0,02} mm	R mm	Artikelnummer Part number	Webcode www.simtek.com/webcode	Unsere erste Wahl Our first choice	Anzahl Schneiden Number of cutting edges	Connectcode www.simtek.com/ccode
▼ w = 3,2 mm						
3,2	0,2	MM4.06.0320.02 GR/L	R AYKP L AYKN	X800 GT42	3	MM4.82.3.2
▼ w = 4,3 mm						
4,3	0,2	MM4.08.0430.02 GR/L	R AYKS L AYKQ	X800 GT42	3	MM4.82.4.3
▼ w = 5,4 mm						
5,4	0,2	MM4.10.0545.02 GR/L	R AYKU L AYKT	X800 GT42	3	MM4.82.5.4
▼ w = 6,5 mm						
6,5	0,2	MM4.12.0650.02 GR/L	R AYKW L AYKV	X800 GT42	3	MM4.82.6.5

Bestellbeispiel // Order example: **MM4.08.0430.02 GR X800** (R = Rechte Ausführung // Right hand version, X800 = Schneidstoff // Grade)

simmill AX
 simmill PMX
 simmill PX
 simmill SX
 simmill UX
 simmill VX
 simmill H2
 simmill K2
 simmill MX
 simmill OS
 Index

Allgemeines Nutfräsen

Nutfräsen gerader Nutformen. Geeignet für alle Materialien.

General groove milling

General groove milling. For use in all materials.

Passende Klemmhalter auf Seite // Suitable toolholders on page
617, 618

Bitte Hinweise im Anhang beachten // Please read add. notes
ALL (Seite/Page 645)



Legende
 Legend **650**



Oder besuchen Sie // Or Visit
www.simtek.info/cp/1212

Passende Scheibenfräser finden Sie auf den Seiten 617 und 618
 Compatible milling cutters can be found on pages 617 and 618

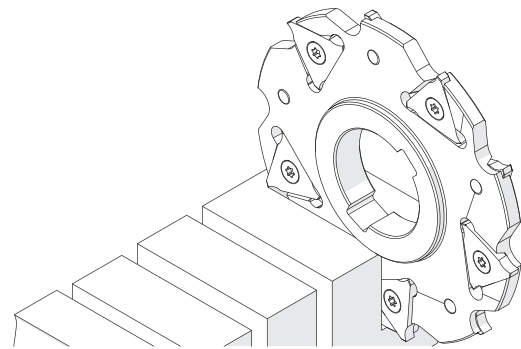
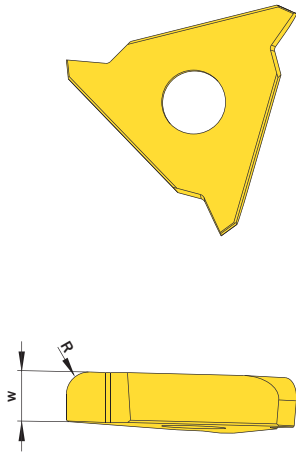


Illustration zeigt beispielhafte Anwendungsmöglichkeit mit ähnlichem Werkzeug.
 Image shows exemplary application possibility with similar tool.

Abbildung zeigt / Drawing shows: MM4.08.0430.20 G R

w	R	Artikelnummer Part number	Webcode www.simtek.com/webcode	Unsere erste Wahl Our first choice	Anzahl Schneiden Number of cutting edges	Connectcode www.simtek.com/code
▼ w = 3,26 mm						
3,26	2,0	MM4.06.0320.20 GR/L	R AZN7 L AZN6	X800 GT42	3	MM4.82.3.2
▼ w = 4,36 mm						
4,36	2,0	MM4.08.0430.20 GR/L	R AZPB L AZPA	X800 GT42	3	MM4.82.4.3
▼ w = 4,38 mm						
4,38	2,5	MM4.08.0430.25 GR/L	R AZN9 L AZN8	X800 GT42	3	MM4.82.4.3
▼ w = 5,52 mm						
5,52	2,0	MM4.10.0545.20 GR/L	R AZPD L AZPC	X800 GT42	3	MM4.82.5.4
▼ w = 5,53 mm						
5,53	2,5	MM4.10.0545.25 GR/L	R AZPG L AZPE	X800 GT42	3	MM4.82.5.4
▼ w = 5,59 mm						
5,59	4,0	MM4.10.0545.40 GR/L	R AZPH L AZPJ	X800 GT42	3	MM4.82.5.4
▼ w = 6,59 mm						
6,59	2,5	MM4.12.0650.25 GR/L	R AZPM L AZPK	X800 GT42	3	MM4.82.6.5
▼ w = 6,65 mm						
6,65	4,0	MM4.12.0650.40 GR/L	R AZPP L AZPN	X800 GT42	3	MM4.82.6.5

Bestellbeispiel // Order example: **MM4.10.0545.20 GR X800** (R = Rechte Ausführung // Right hand version, X800 = Schneidstoff // Grade)

Individualwerkzeuge // Customized tools

Kundenindividuelle Werkzeuglösungen Customer-specific tooling solutions



Trägerwerkzeug für den Einsatz auf Rundtaktmaschinen. Das modular aufgebaute Trägerwerkzeug ermöglicht die Einhaltung feinsten Fertigungstoleranzen dank hochpräziser radialer Verstellmöglichkeit.

Modular toolholder for use on rotary transfer machines. High-precision radial adjustment possibility enables maintenance of highest manufacturing tolerances.

SIMTEK Individualwerkzeuge bieten unzählige Vorteile! Neben unserem Anspruch, jeweils die qualitativ bestmögliche Werkzeuglösung für Ihre Anwendung anzubieten, ist es auch unser Bestreben Ihnen durch ein SIMTEK Individualwerkzeug den größtmöglichen wirtschaftlichen Nutzen zu liefern! Tausende, aktuell erfolgreich eingesetzte Individualwerkzeuge bestätigen dies!

Kontaktieren Sie uns und lassen auch Sie sich von den Vorteilen mit SIMTEK Individualwerkzeugen überzeugen!

SIMTEK individual tools offer countless advantages! In addition to our goal to offer the qualitatively best possible tooling solution for your application, we also aspire to provide you with the greatest possible economic benefit from a customized SIMTEK tool! Thousands of currently successfully used SIMTEK individual tools confirm this!

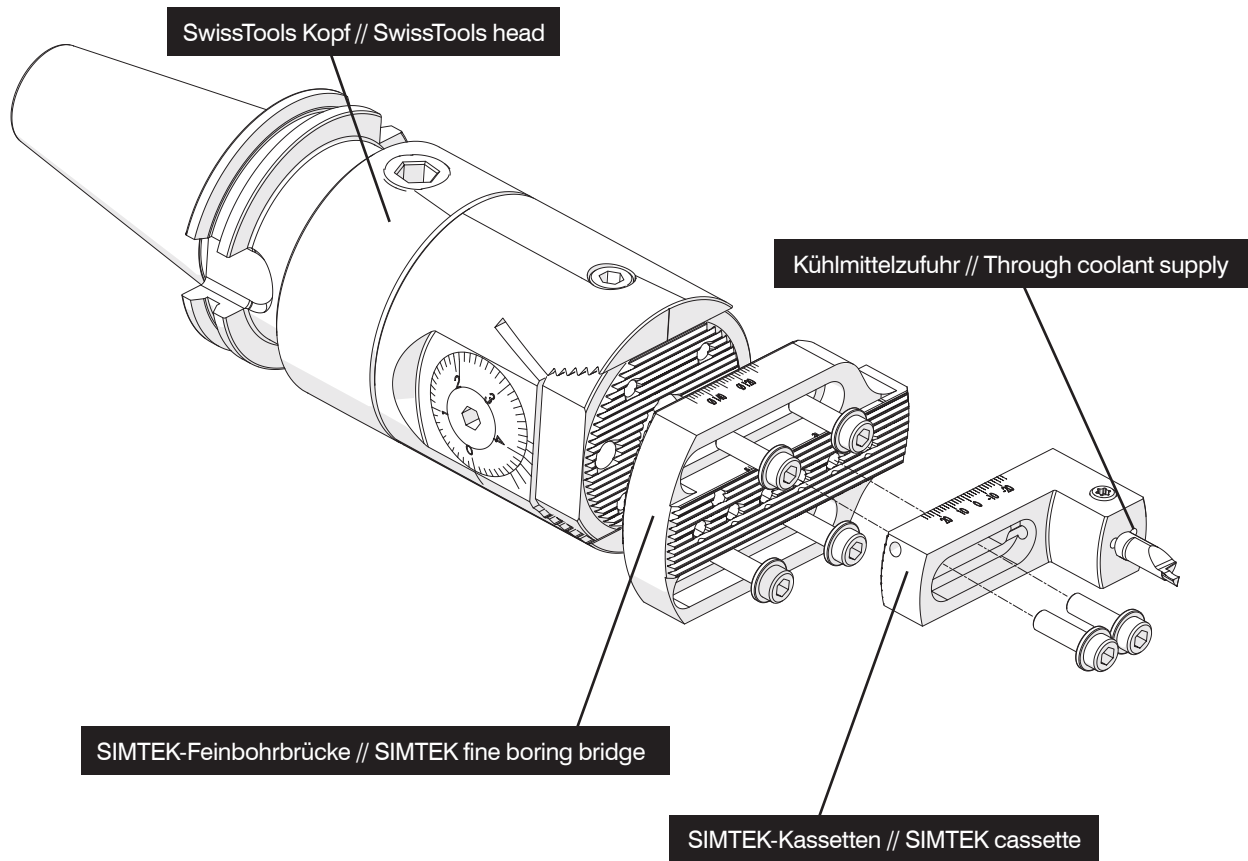
Contact us and convince yourself of the advantages of SIMTEK individual tools!

Das Werkzeugsystem im Überblick The Tool System Overview

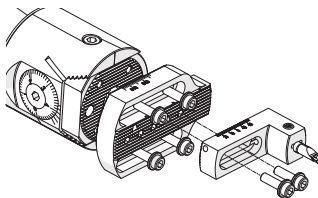
Ausspindeln ab \varnothing 0,3 mm und Axialstechen \varnothing 6,2 mm.
Fine Boring as of \varnothing 0,3 mm and Face Grooving as of \varnothing 6,2 mm.



Das Werkzeugsystem im Detail The Tool System in Detail



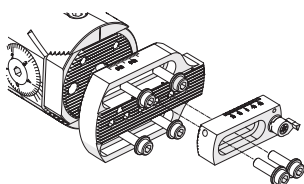
Verfügbare Kassetten und Anwendungsgebiete Available cassettes and applications



Für simturn AX Schneideinsätze // For simturn AX inserts

Durchmesserbereich // Diameter range: \emptyset 0,3 - \emptyset 149,0 mm
Connectcode: A06R

Für simturn AX Schneidwerkzeuge mit dem Connectcode
A04.R, A04C.R und A06.R, siehe Seite 71 – 135
For simturn AX cutting tools with Connectcode
A04.R, A04C.R and A06.R, see Page 71 – 135



Für simturn DX Schneidplatten // For simturn DX inserts

Durchmesserbereich // Diameter range: \emptyset 14,0 - \emptyset 160,0 mm
Connectcode: D14 | D14.A.R


Schneidplatten auf Seite // Cutting inserts on page:
171, 209, 210, 211, 212


Adapter „SIMTEK/SwissTools“


Feinbohrbrücke für SwissTools-Köpfe „B10...“.

Adaptor „SIMTEK/SwissTools“

Adaptor for SwissTools-Heads „B10...“.



TW ST  **Legende 650**
 Legend

 Scan QR-Code **Oder besuchen Sie // Or Visit**
www.simtek.info/cp/961

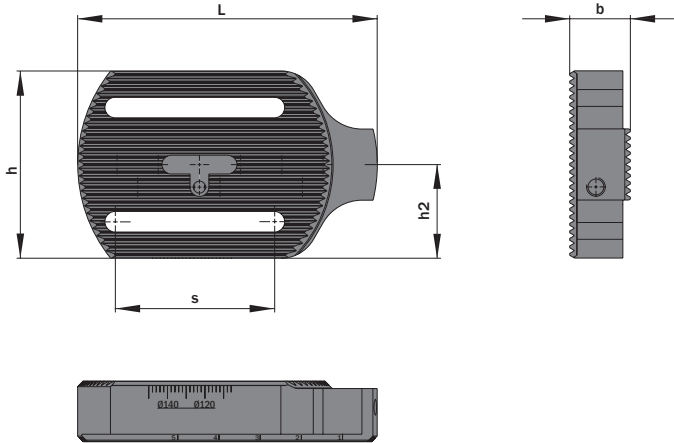


Abbildung zeigt / Drawing shows: MOS.STA.B10.080

L	Artikelnummer Part number	Webcode www.simtek.com/webcode	b	h	h2	S	Connectcode www.simtek.com/ccode
mm			mm	mm	mm	mm	
80,0	MOS.STA.B10.080	AU6X	16,2	50,0	25,0	42,5	MOS

Bestellbeispiel // Order example: **MOS.STA.B10.080**

simmill AX

simmill PMX

simmill PX

simmill SX

simmill UX

simmill VX

simmill H2

simmill K2

simmill MX

simmill OS

Index

Kassette „A04“ und „A06“

Für simturn A04- und A06-Schneidwerkzeuge.
 Passend zu Adapter „MOS.STA...“.

Cassette „A04“ and „A06“

For simturn A04 and A06-cutting inserts.
 Suitable adaptor: „MOS.STA...“.

Anzugsmoment (Schraube) // Tightening torque (screw)

7,0 Nm

Bitte Hinweise im Anhang beachten // Please read add. notes

ALL (Seite/Page 645)



Legende
 Legend

650



Scan
 QR-Code

Oder besuchen Sie // Or Visit
www.simtek.info/cp/963

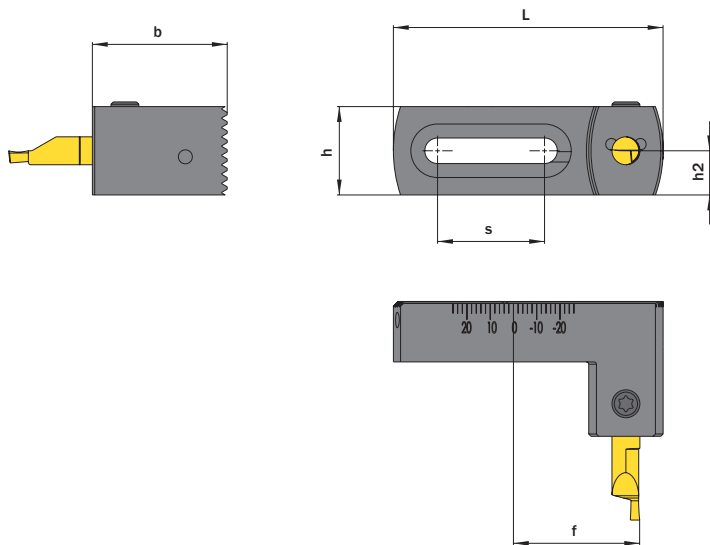


Abbildung zeigt / Drawing shows: MOS.STK.A06.A

L	Artikelnummer Part number	Webcode www.simtek.com/webcode	b	f	h	h2	S	Schraube Screw	Schraubenschlüssel Screw driver	Connectcode www.simtek.com/code
mm			mm	mm	mm	mm	mm			
58,0	MOS.STK.A04.A	AVFY	29,0	26,12	19,0	9,5	23,0	A M6x7,5 T15F	T15F	A04.R A04C.R
58,0	MOS.STK.A06.A	AU6Y	29,0	27,13	19,0	9,5	23,0	A M6x7,5 T15F	T15F	A06.R

Bestellbeispiel // Order example: **MOS.STK.A04.A**

simmill AX

simmill PMX

simmill PX

simmill SX

simmill UX

simmill VX

simmill H2

simmill K2

simmill MX

simmill OS

Index

Kassette „D14“

Für simturn D14-Schneidwerkzeuge. Passend zu Adapter „MOS.STA...“.

Cassette „D14“

For simturn D14-cutting inserts. Suitable adaptor: „MOS.STA...“.

Anzugsmoment (Schraube) // Tightening torque (screw)

6,0 Nm

Bitte Hinweise im Anhang beachten // Please read add. notes

ALL (Seite/Page 645)

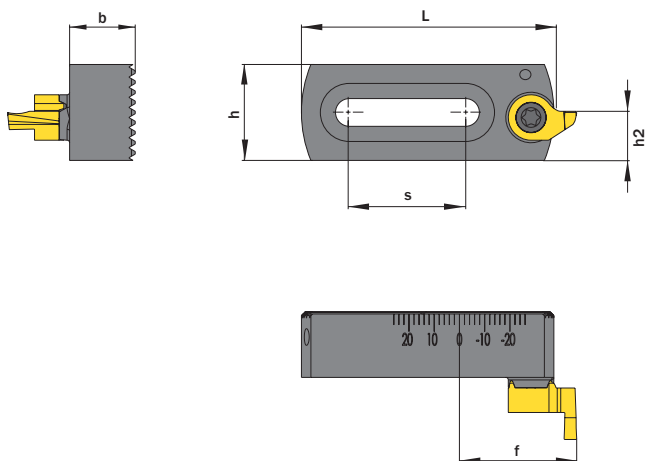


Legende
 Legend **650**



Scan
 QR-Code

Oder besuchen Sie // Or Visit
www.simtek.info/cp/962



Eine Auswahl passender Schneidplatten finden Sie auf Seite:

168, 207, 208, 210, 211

A selection of compatible Cutting Inserts can be found on page:

168, 207, 208, 210, 211

Abbildung zeigt / Drawing shows: MOS.STK.D14.A

L	Artikelnummer Part number	Webcode www.simtek.com/webcode	b	f	h	h2	S	Schraube Screw	Schraubenschlüssel Screw driver	Connectcode www.simtek.com/code
mm			mm	mm	mm	mm	mm			
50,0	MOS.STK.D14.A	AU6Z	13,0	22,67	19,0	9,5	23,0	MM5x13 T20R	T20R	D14 D14.A.R

Bestellbeispiel // Order example: **MOS.STK.D14.A**

simmill AX

simmill PMX

simmill PX

simmill SX

simmill UX

simmill VX

simmill H2

simmill K2

simmill MX

simmill OS

Index

Klemmhalter / Adapter, Innenbearbeitung

Adapter für simmill OS D07- oder simmill OS D10-Schneidplatten auf precium Feinausdrehwerkzeuge. Schwingungsgedämpfter Hartmetall-Rundschaft mit Kühlmittelzufuhr.

Toolholder / Adapter, For Internal Applications

Adapter for simmill OS D07 or simmill OS D10 inserts on precium fine boring units. Anti-vibration solid carbide round shank toolholder with through coolant.

Anzugsmoment (Schraube) // Tightening torque (screw)

"D M2x7,5 T7F": 1,2 Nm
 "D M3x9 T9F": 2,1 Nm

Bitte Hinweise im Anhang beachten // Please read add. notes

ALL (Seite/Page 645)



Legende Legend **650**

Scan QR-Code

Oder besuchen Sie // Or Visit www.simtek.info/cp/1059

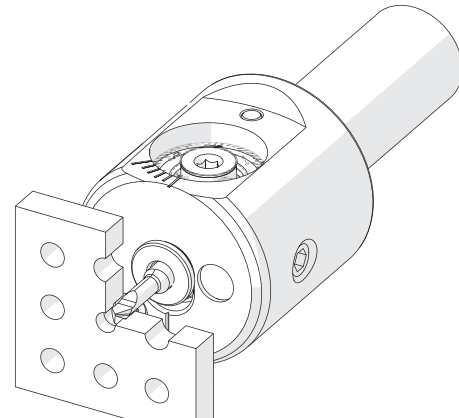
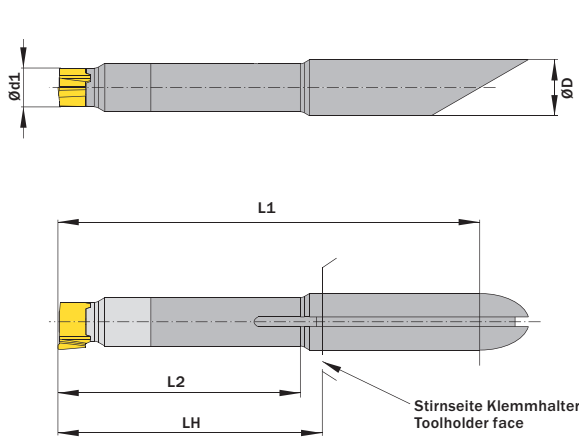


Illustration zeigt beispielhafte Anwendungsmöglichkeit mit ähnlichem Werkzeug.
 Image shows exemplary application possibility with similar tool.

Abbildung zeigt / Drawing shows: D07.A07.30 HM

ØD ^{h6} mm	L2 mm	Artikelnummer Part number	Webcode www.simtek.com/webcode	Ød1 mm	ØDmin (Min. Bohrung) ØDmin (min. bore) mm	L1 mm	LH mm	Schraube Screw	Schraubenschlüssel Screw driver	Connectcode www.simtek.com/code
▼ L2 = 30,0 mm										
7,0	30,0	D07.A07.30 HM	AW1M	4,8	6,9	52,2	33,0	D M2x7,5 T7F	T7F	MOS.D07
▼ L2 = 35,0 mm										
7,0	35,0	D10.A07.35 HM	AW1S	7,0	9,9	57,2	38,0	D M3x9 T9F	T9F	MOS.D10
▼ L2 = 50,0 mm										
7,0	50,0	D10.A07.50 HM	AX0T	7,0	9,9	72,2	53,0	D M3x9 T9F	T9F	MOS.D10

Bestellbeispiel // Order example: **D10.A07.35 HM**

simmill AX

simmill PMX

simmill PX

simmill SX

simmill UX

simmill VX

simmill H2

simmill K2

simmill MX

simmill OS

Index

Feinausdrehen

Ausspindeln von Bohrungen auf precium Feinausdrehwerkzeugen.

Fine Boring

Fine boring on precium fine boring units.

Bitte Hinweise im Anhang beachten // Please read add. notes
ALL (Seite/Page 645)



SP
HM R

Legende
Legend **650**

Scan
QR-Code

Oder besuchen Sie // Or Visit
www.simtek.info/cp/1009

Mehr Informationen unter www.precium.de
 More information on www.precium.de

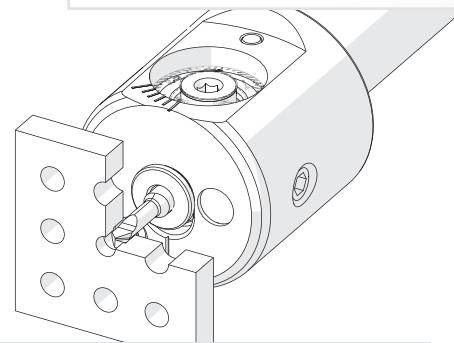
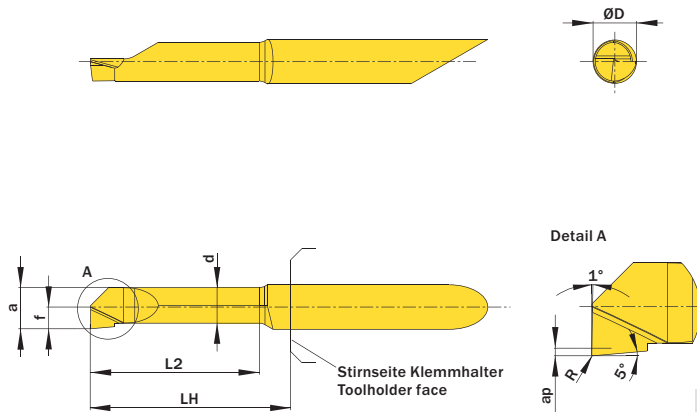


Illustration zeigt beispielhafte Anwendungsmöglichkeit mit ähnlichem Werkzeug.
 Image shows exemplary application possibility with similar tool.

Abbildung zeigt / Drawing shows: A04.0195.15.39.05 Y R

ØD	L2	ØDmin (Min. Bohrung) ØDmin (min. bore)	R	AXC	Artikelnummer Part number	Webcode www.simtek.com/webcode	Unsere erste Wahl Our first choice	a	d	f	LH	ap	Connectcode www.simtek.com/ccode
mm	mm	mm	mm				P M K N S	mm	mm	mm	mm	mm	
▼ ØDmin (Min. Bohrung) // ØDmin (min. bore) = 0,3 mm													
4,0	1,2	0,3	-	0	A04.0010.01.03.00 YR	AW08	X800 GT42	0,25	0,19	0,15	13,0	0,03	MOS.A04.R
▼ ØDmin (Min. Bohrung) // ØDmin (min. bore) = 0,6 mm													
4,0	2,5	0,6	-	0	A04.0025.02.06.00 YR	AW09	X800 GT42	0,55	0,46	0,3	13,0	0,05	MOS.A04.R
▼ ØDmin (Min. Bohrung) // ØDmin (min. bore) = 1,0 mm													
4,0	4,0	1,0	0,05	0	A04.0045.04.10.05 YR	AW1A	X800 GT42	0,95	0,8	0,5	13,0	0,1	MOS.A04.R
4,0	6,0	1,0	0,05	0	A04.0045.06.10.05 YR	AX0U	X800 GT42	0,95	0,8	0,5	13,0	0,1	MOS.A04.R
▼ ØDmin (Min. Bohrung) // ØDmin (min. bore) = 2,2 mm													
4,0	6,0	2,2	0,05	1	A04.0095.06.22.05 YR	AW1B	X800 GT42	2,0	1,55	1,1	13,0	0,2	MOS.A04.R
4,0	9,1	2,2	0,05	1	A04.0095.09.22.05 YR	AX0V	X800 GT42	2,0	1,55	1,1	13,0	0,2	MOS.A04.R
▼ ØDmin (Min. Bohrung) // ØDmin (min. bore) = 3,2 mm													
4,0	10,2	3,2	0,05	1	A04.0145.10.32.05 YR	AW1C	X800 GT42	3,0	2,55	1,6	13,0	0,2	MOS.A04.R
4,0	15,2	3,2	0,05	1	A04.0145.15.32.05 YR	AX0W	X800 GT42	3,0	2,55	1,6	18,0	0,2	MOS.A04.R
4,0	20,3	3,2	0,05	1	A04.0145.20.32.05 YR	AX0X	X800 GT42	3,0	2,55	1,6	23,0	0,2	MOS.A04.R
▼ ØDmin (Min. Bohrung) // ØDmin (min. bore) = 3,9 mm													
4,0	15,2	3,9	0,05	1	A04.0195.15.39.05 YR	AW1D	X800 GT42	3,7	3,2	1,95	18,0	0,3	MOS.A04.R
4,0	20,3	3,9	0,05	1	A04.0195.20.39.05 YR	AX0Y	X800 GT42	3,7	3,2	1,95	23,0	0,3	MOS.A04.R
4,0	25,4	3,9	0,05	1	A04.0195.25.39.05 YR	AX0Z	X800 GT42	3,7	3,2	1,95	28,0	0,3	MOS.A04.R
▼ ØDmin (Min. Bohrung) // ØDmin (min. bore) = 5,2 mm													
7,0	20,3	5,2	0,05	1	A07.0245.20.52.05 YR	AW1E	X800 GT42	5,0	4,25	2,6	23,0	0,5	MOS.A07.R
7,0	25,4	5,2	0,05	1	A07.0245.25.52.05 YR	AX00	X800 GT42	5,0	4,25	2,6	28,0	0,5	MOS.A07.R
7,0	30,5	5,2	0,05	1	A07.0245.30.52.05 YR	AX01	X800 GT42	5,0	4,25	2,6	33,0	0,5	MOS.A07.R
▼ ØDmin (Min. Bohrung) // ØDmin (min. bore) = 6,2 mm													
7,0	20,3	6,2	0,05	1	A07.0295.20.62.05 YR	AW1F	X800 GT42	6,0	5,25	3,1	23,0	0,5	MOS.A07.R
7,0	25,4	6,2	0,05	1	A07.0295.25.62.05 YR	AX02	X800 GT42	6,0	5,25	3,1	28,0	0,5	MOS.A07.R
7,0	30,5	6,2	0,05	1	A07.0295.30.62.05 YR	AX03	X800 GT42	6,0	5,25	3,1	33,0	0,5	MOS.A07.R
▼ ØDmin (Min. Bohrung) // ØDmin (min. bore) = 6,9 mm													
7,0	25,4	6,9	0,2	1	A07.0345.25.69.20 YR	AW1G	X800 GT42	6,7	6,0	3,45	28,0	0,5	MOS.A07.R
7,0	30,5	6,9	0,2	1	A07.0345.30.69.20 YR	AX04	X800 GT42	6,7	6,0	3,45	33,0	0,5	MOS.A07.R
7,0	40,6	6,9	0,2	1	A07.0345.40.69.20 YR	AX05	X800 GT42	6,7	6,0	3,45	43,0	0,5	MOS.A07.R

Bestellbeispiel // Order example: A04.0195.15.39.05 YR X800 (R = Rechte Ausführung // Right hand version, X800 = Schneidstoff // Grade)

Feinausdrehen

Ausspindeln von Bohrungen auf precium Feinausdrehwerkzeugen.
 Passende Adapter auf Seite 604.

Fine Boring

Fine boring on precium fine bore units. Suitable adaptor on page 604.

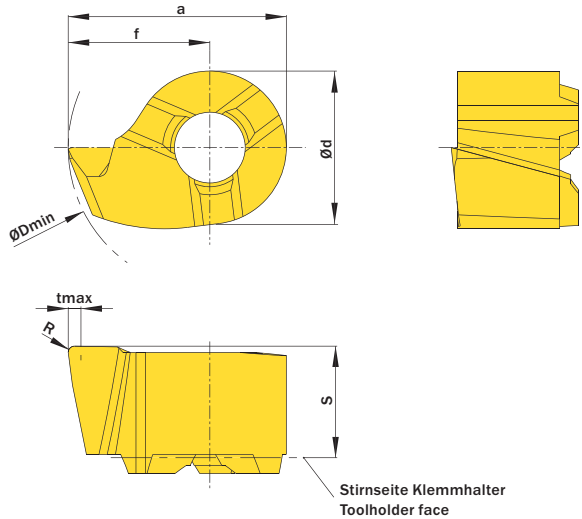
Passende Klemmhalter auf Seite // Suitable toolholders on page **635**

Bitte Hinweise im Anhang beachten // Please read add. notes
ALL (Seite/Page 645)



Legende
 Legend **650**

Scan QR-Code Oder besuchen Sie // Or Visit
www.simtek.info/cp/1010



Stirnseite Klemmhalter
 Toolholder face

Mehr Informationen unter www.precium.de
 More information on www.precium.de

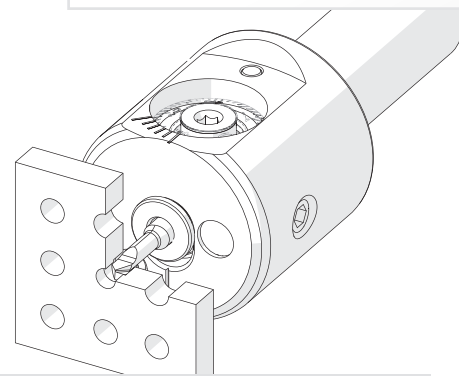


Illustration zeigt beispielhafte Anwendungsmöglichkeit mit ähnlichem Werkzeug.
 Image shows exemplary application possibility with similar tool.

Abbildung zeigt / Drawing shows: D07.0445.20.09 YR

f	R	ØDmin (Min. Bohrung) ØDmin (min. bore)	Artikelnummer Part number	Webcode www.simtek.com/webcode	Unsere erste Wahl Our first choice	a	Ød	S	tmax	Connectcode www.simtek.com/code
mm	mm	mm			P M K N S	mm	mm	mm	mm	
▼ ØDmin (Min. Bohrung) // ØDmin (min. bore) = 6,9 mm										
3,45	0,2	6,9	D07.0345.20.07 YR	AW1H	X800 GT42	5,85	4,8	3,5	0,4	MOS.D07
▼ ØDmin (Min. Bohrung) // ØDmin (min. bore) = 7,9 mm										
3,95	0,2	7,9	D07.0395.20.08 YR	AW1J	X800 GT42	6,35	4,8	3,5	0,4	MOS.D07
▼ ØDmin (Min. Bohrung) // ØDmin (min. bore) = 8,9 mm										
4,45	0,2	8,9	D07.0445.20.09 YR	AW1K	X800 GT42	6,85	4,8	3,5	0,4	MOS.D07
▼ ØDmin (Min. Bohrung) // ØDmin (min. bore) = 9,9 mm										
4,95	0,2	9,9	D10.0495.20.10 YR	AW1N	X800 GT42	8,45	7,0	3,9	0,4	MOS.D10
▼ ØDmin (Min. Bohrung) // ØDmin (min. bore) = 11,9 mm										
5,95	0,2	11,9	D10.0595.20.12 YR	AW1P	X800 GT42	9,45	7,0	3,9	0,4	MOS.D10
▼ ØDmin (Min. Bohrung) // ØDmin (min. bore) = 13,9 mm										
6,95	0,2	13,9	D10.0695.20.14 YR	AW1Q	X800 GT42	10,45	7,0	3,9	0,4	MOS.D10

Bestellbeispiel // Order example: **D10.0695.20.14 YR X800** (R = Rechte Ausführung // Right hand version, X800 = Schneidstoff // Grade)

simmill AX
 simmill PMX
 simmill PX
 simmill SX
 simmill UX
 simmill VX
 simmill H2
 simmill K2
 simmill MX
 simmill OS
 Index

Index

Seite // Page

639

Schnittgeschwindigkeiten
Cutting Speed Recommendation

642

Formelsammlung Schnittdatenberechnung, innen
Formulary for Cutting Data Calculation, internal

643

Formelsammlung Schnittdatenberechnung, außen
Formulary for Cutting Data Calculation, external

644

Formelsammlung Schnittdatenberechnung, linear
Formulary for Cutting Data Calculation, linear

645

Hinweisliste
Additional information

650

Legende
Legend

Schnittgeschwindigkeiten Cutting speed recommendation

ISO-Gruppe ISO-Group	Empfohlener Schneidstoff Recommended Cutting Grade	Werkstückstoff Work piece material	Untergruppe Sub-group	Alternativer Schneidstoff Alternative cutting grade	Vc m/min (Start)
P	X800 X802 X804 X808	Stahl, unlegiert <i>Steel, unalloyed</i>	≤ 0,15 % C	*T57	300
			0,15 - 0,4 % C	*T57	270
			≥ 0,4 % C	*T57	250
		Stahl, niedriglegiert (Legierungsanteil ≤ 5%) <i>Steel, low alloyed (alloying elements ≤ 5%)</i>	Nicht gehärtet <i>Non-hardened</i>	*T57	240
			Vergütet <i>Hardened</i>	*T57	140
		Stahl, hochlegiert (Legierungsanteil > 5%) <i>Steel, high alloyed (Alloying elements > 5%)</i>	Geglüht <i>Annealed</i>	*T57	160
			Vergütet <i>Hardened</i>	*T57	130
		Stahlguss <i>Castings</i>	Unlegiert <i>Unalloyed</i>	*T57	220
			Niedriglegiert (Legierungsanteil ≤ 5%) <i>Low alloyed (Alloying elements ≤ 5%)</i>	*T57	170
			Hochlegiert (Legierungsanteil > 5%) <i>High alloyed (Alloying elements > 5%)</i>	*T57	130
M	X800 X802 X804 X808	Rostfreier Stahl Ferritisch/Martensitisch <i>Stainless Steel Ferritic/Martensitic</i>	Nicht gehärtet <i>Non-hardened</i>	*T57	210
			PH-gehärtet <i>PH-hardened</i>	*T57	150
			Gehärtet <i>Hardened</i>	*T57	150
		Rostfreier Stahl Austenitisch <i>Stainless Steel Austenitic</i>	Austenitisch <i>Austenitic</i>	*T57	200
			PH-gehärtet <i>PH-hardened</i>	*T57	140
			Superaustenitisch <i>Super Austenitic</i>	*T57	150
		Rostfreier Stahl Austenitisch-Ferritisch (Duplex) <i>Stainless Steel Austenitic-ferritic (Duplex)</i>	Nicht Schweißbar ≥ 0,05 % C <i>Non-weldable ≥ 0,05 % C</i>	*T57	170
			Schweißbar < 0,05 % C <i>Weldable < 0,05 % C</i>	*T57	140
		Rostfreier Stahl (gegossen) Ferritisch/martensitisch <i>Stainless Steel (Cast) Ferritic/martensitic</i>	Nicht gehärtet <i>Non-hardened</i>	*T57	180
			PH-gehärtet <i>PH-hardened</i>	*T57	130
			Gehärtet <i>Hardened</i>	*T57	140
		Rostfreier Stahl (gegossen) Austenitisch <i>Stainless Steel (Cast) Austenitic</i>	Austenitisch <i>Austenitic</i>	*T57	190
			PH-gehärtet <i>PH-hardened</i>	*T57	130
		Rostfreier Stahl (gegossen) Austenitisch-Ferritisch (Duplex) <i>Stainless Steel (Cast) Austenitic-ferritic (Duplex)</i>	Nicht schweißbar ≥ 0,05 % C <i>Non-weldable ≥ 0,05 % C</i>	*T57	160
Schweißbar < 0,05 % C <i>Weldable < 0,05 % C</i>	*T57		130		

simmill AX

simmill PMX

simmill PX

simmill SX

simmill UX

simmill VX

simmill H2

simmill K2

simmill MX

simmill OS

Index

639

Info

Schnittgeschwindigkeiten
Cutting speed recommendation

ISO-Gruppe ISO-Group	Empfohlener Schnelstoff Recommended Cutting Grade	Werkstückstoff Work piece material	Untergruppe Sub-group	Alternativer Schnelstoff Alternative cutting grade	Vc m/min (Start)		
K	X800 X802 X804 X808	Temperguß <i>Malleable</i>	Ferritisch (kurzspanend) <i>Ferritic (short chipping)</i>	*T57	250		
			Perlitisch (langspanend) <i>Pearlitic (long chipping)</i>	*T57	210		
		Grauguß <i>Grey Cast Iron</i>	Niedrige Festigkeit <i>Low tensile strength</i>	*T57	290		
			Hohe Festigkeit <i>High tensile strength</i>	*T57	220		
			Kugelgraphitguß <i>Spheroidal Graphite cast iron</i>	Ferritisch <i>Ferritic</i>	*T57	170	
		Perlitisch <i>Pearlitic</i>		*T57	160		
		Martensitisch <i>Martensitic</i>		*T57	110		
		N	X800 X802 X804 X808	Aluminiumlegierung, geschmiedet <i>Aluminium alloys, Whrought</i>	Nicht aushärtbar <i>Can not be hardened</i>	*X17	840
					Aushärtbar, Gehärtet <i>Can be hardened, hardened</i>	*X17	750
Aluminiumlegierung, gegossen <i>Aluminium alloys, Cast</i>	Nicht aushärtbar <i>Can not be hardened</i>			*X17	840		
	Aushärtbar, Gehärtet <i>Can be hardened, hardened</i>			*X17	750		
Aluminiumlegierung, gegossen <i>Aluminium alloys, Cast</i>	< 16 % Si			PKD*	340		
	≥ 16 % Si			PKD*	250		
Kupfer- und Kupferlegierung <i>Copper and Copper Alloys</i>	Automatenlegierung, ≥1 % Pb <i>Free Cutting Alloys, ≥1 % Pb</i>			*X17	420		
	Messing, Bleilegierung ≤ 1 % Pb <i>Brass, leaded bronzes, ≤ 1 % Pb</i>			*X17	420		
	Bronze, bleifreies Kupfer einschl. Elektrolytkupfer <i>Bronze, lead-free copper incl. electrolytic copper</i>			*X17	300		

Schnittgeschwindigkeiten Cutting speed recommendation

ISO-Gruppe ISO-Group	Empfohlener Schneidstoff Recommended Cutting Grade	Werkstückstoff Work piece material	Untergruppe Sub-group	Alternativer Schneidstoff Alternative cutting grade	Vc m/min (Start)
S	GT42	Warmfeste Superlegierungen Fe-basiert <i>Heat-resistant super alloys Fe-based</i>	Geglüht oder lösungsbehandelt <i>Annealed or solution treated</i>	*T57	60
			Ausgehärtet oder lösungsbehandelt und ausgehärtet <i>Aged or solution treated and aged</i>	*T57	40
		Warmfeste Superlegierungen Ni-basiert <i>Heat-resistant super alloys Ni-based</i>	Geglüht oder lösungsbehandelt <i>Annealed or solution treated</i>	*T57	50
			Ausgehärtet oder lösungsbehandelt und ausgehärtet <i>Aged or solution treated and aged</i>	*T57	30
			Gegossen oder gegossen und ausgehärtet <i>Cast or Cast and aged</i>	*T57	40
		Warmfeste Superlegierungen Co-basiert <i>Heat-resistant super alloys Co-based</i>	Geglüht oder lösungsbehandelt <i>Annealed or solution treated</i>	*T57	20
	Lösungsbehandelt und ausgehärtet <i>Solution treated and aged</i>		*T57	15	
	Gegossen oder gegossen und ausgehärtet <i>Cast or Cast and aged</i>		*T57	15	
	Titanlegierung <i>Titanium Alloys</i>	Handelsüblich rein (99,5 % Ti) <i>Commercial pure (99,5 % Ti)</i>	*T57	110	
		α, ähnlich α und α + β Legierungen, geglüht <i>α, near α and α + β alloys, annealed</i>	*T57	60	
		α+β Legierungen in ausgehärtetem Zustand sowie β Legierungen. Geglüht oder ausgehärtet <i>α+β Alloys in aged conditions as well as β alloys. Annealed or aged.</i>	*T57	50	
	H	GT42 *	Hochvergütete und gehärtete Stähle <i>Tempered and hardened steel</i>	*T91	70
Kokillenhartguß, gegossen oder gegossen und ausgehärtet <i>Chilled cast iron, cast or cast and aged</i>			*T91	130	

*) Zusätzlich wird eine besondere Schneidengeometrie für beste Ergebnisse empfohlen. Bitte sprechen Sie uns im Bedarfsfall darauf an.
For best results, a special cutting edge geometry is recommended here. Please contact us.

simmill AX

simmill PMX

simmill PX

simmill SX

simmill UX

simmill VX

simmill H2

simmill K2

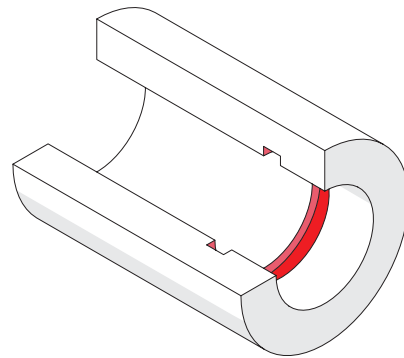
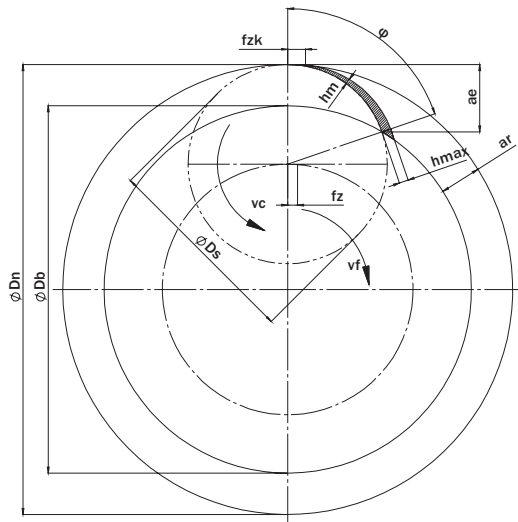
simmill MX

simmill OS

Index

Info

Schnittwertberechnung beim Innenzirkularfräsen Cutting data calculation for internal groove milling by circular interpolation



Berechnung der effektiven Schnitttiefe // Calculating the actual depth of cut

$$ae = (D_n^2 - D_b^2) / (4(D_n - D_s))$$

Berechnung des Vorschubs pro Zahn // Calculating the feed rate per cutting edge

$$\varphi = \arccos(1 - (2(ae/D_s)))$$

$$fz = (h_{max} * D_s * \pi * \varphi) / (720 * ae)$$

Berechnung des Vorschubs für den Fräsermittelpunkt // Calculating the feed of tool center

$$n = vc / (\pi * D_s)$$

$$vf = fz * Z_{EFP} * n$$

$$v_{eff} = (fz * Z_{EFP} * n * D_n) / (D_n - D_s)$$

$$fz_k = v_{eff} / (Z_{EFP} * n)$$

ae Effektive Schnitttiefe // Actual depth of cut

φ Eingriffswinkel // Angle of engagement

fz Vorschub pro Zahn // Feed per cutting edge

n Drehzahl // Revolutions per minute

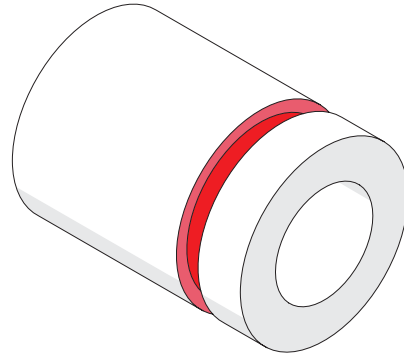
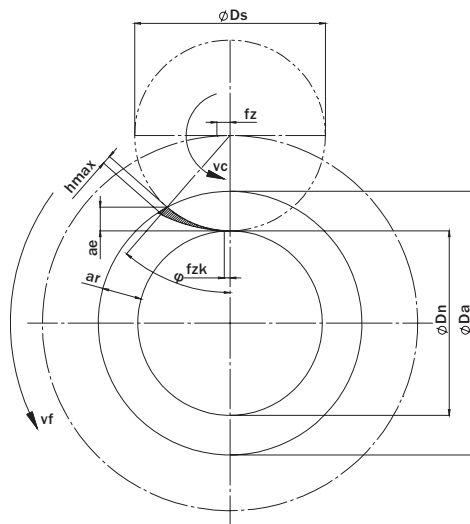
vf Vorschubgeschwindigkeit der Fräsermitte // Feed rate of tool center

v_{eff} Effektive Vorschubgeschwindigkeit // Actual feed rate

fz_k Vorschub pro Zahn auf dem Nutgrund // Feed per cutting edge on the groove bottom

Z_{EFP} Anzahl wirksamer Schneiden, umfangseitig // Peripheral effective cutting edge count

Schnittwertberechnung beim Außenzirkularfräsen Cutting data calculation for external groove milling by circular interpolation



Berechnung der effektiven Schnitttiefe // Calculating the actual depth of cut

$$a_e = (D_a^2 - D_n^2) / 4(D_a + D_s)$$

Berechnung des Vorschubs pro Zahn // Calculating the feed rate per cutting edge

$$\varphi = \arccos(1 - 2(a_e / D_s))$$

$$f_z = (h_{max} * D_s * \pi * \varphi) / (720 * a_e)$$

Berechnung des Vorschubs für den Fräsermittelpunkt // Calculating the feed of tool center

$$n = v_c / (\pi * D_s)$$

$$v_f = f_z * Z_{EFP} * n$$

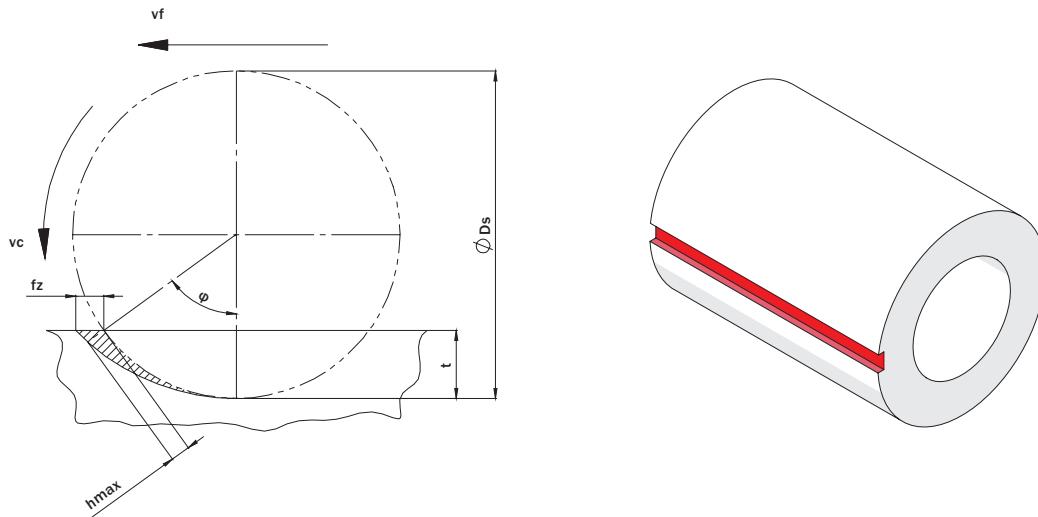
$$v_{f_{eff}} = (f_z * Z_{EFP} * n * D_n) / (D_n + D_s)$$

$$f_{zk} = v_{f_{eff}} / (Z_{EFP} * n)$$

- ae Effektive Schnitttiefe // Actual depth of cut
- φ Eingriffswinkel // Angle of engagement
- fz Vorschub pro Zahn // Feed per cutting edge
- n Drehzahl // Revolutions per minute
- v_f Vorschubgeschwindigkeit der Fräsermitte // Feed rate of tool center
- v_{f_{eff}} Effektive Vorschubgeschwindigkeit // Actual feed rate
- f_{zk} Vorschub pro Zahn auf dem Nutgrund // Feed per cutting edge on the groove bottom
- Z_{EFP} Anzahl wirksamer Schneiden, umfangseitig // Peripheral effective cutting edge count

Info

Schnittwertberechnung beim Linearfräsen Cutting data calculation for linear groove milling



Berechnung des Vorschubs pro Zahn // Calculating the feed rate per cutting edge

$$\varphi = \arccos(1 - (2(t/D_s)))$$

$$f_z = (h_{max} * D_s * \pi * \varphi) / (720 * t)$$

Berechnung des Vorschubs für den Fräsermittelpunkt // Calculating the feed of tool center

$$n = v_c / (\pi * D_s)$$

$$v_f = f_z * Z_{EFP} * n$$

φ Eingriffswinkel // Angle of engagement

f_z Vorschub pro Zahn // Feed per cutting edge

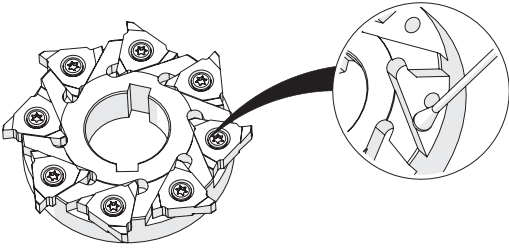

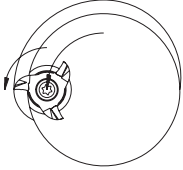
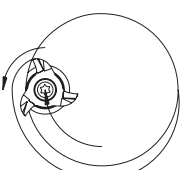
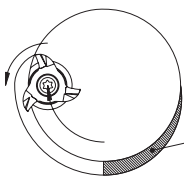
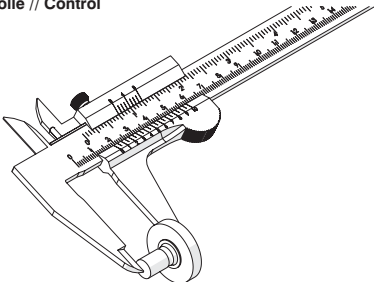
n Drehzahl // Revolutions per minute

v_f Vorschubgeschwindigkeit der Fräsermitte // Feed rate of tool center

Z_{EFP} Anzahl wirksamer Schneiden, umfangseitig // Peripheral effective cutting edge count

Hinweisliste Additional information

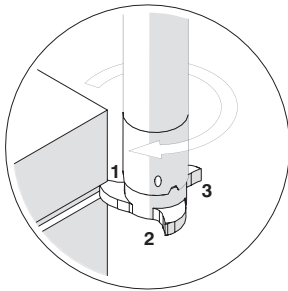
ALL

<p>Reinigung // Cleaning</p>  <p>Bitte Plattensitz vor Gebrauch gründlich reinigen. Please clean insert seat well before use.</p>	<p>Bestands- und Preisinfo // Stock and price info</p> <p>Verfügbare Schneidstoffe, aktuelle Bestände und Preise finden Sie auf www.simtek.com/webcode und in der aktuellen Preisliste.</p> <p>Available grades, stock and prices can be found up-to-date on www.simtek.com/webcode/ as well as in the latest price list.</p>  <p>Nutzen Sie dazu den auf der Katalogseite angegebenen Webcode.</p> <p>Please use the webcode which is given on the catalog page.</p>				
<p>Fräsverfahren // Milling method</p> <div style="display: flex; justify-content: space-around;"> <div style="text-align: center;"> <p>Gegenlaufräsen Upcut Milling</p>  </div> <div style="text-align: center;"> <p>Gleichlaufräsen Synchronous Milling</p>  </div> </div> <p>Werkzeugbewegung dargestellt. Das Gleichlaufräsverfahren ist das empfohlene Fräsverfahren für SIMTEK-Fräswerkzeuge.</p> <p>Tool movement shown. The synchronous milling method is the recommended milling method for SIMTEK milling tools.</p>	<p>Einfahrschleife // Immersion Loop</p>  <p>Einfahrschleife Immersion Area</p> <p>Für eine optimale Anwendung wird empfohlen, in einer Einfahrschleife unter 45° bis 180° auf die volle Nuttiefe zu fräsen.</p> <p>We recommend to immerse the groove with an immersion loop between 45° and 180° until the maximum groove depth is reached.</p>				
<p>Kontrolle // Control</p>  <p>Bitte prüfen Sie Ihre Werkstücke regelmäßig auf maßliche Eignung. Please control your work pieces frequently.</p>	<p>Schnittparameter // Cutting parameters</p> <table border="1" data-bbox="821 1388 1316 1444"> <tr> <td>Schnittwerte (Startwerte) Cutting parameters (Start)</td> <td>f_{zm} *** mm</td> <td>v_{max} *** mm</td> <td>V_c Seite/Page ***</td> </tr> </table> <p>Alle angegebenen Schnittwerte sind als Startwerte zu verstehen.</p> <p>Die optimalsten Werte sind von verschiedensten Faktoren (bspw. Maschinenbedingungen) abhängig und können über oder unter diesem Startwert liegen.</p> <p>Given cutting parameters are ment as initial values.</p> <p>The best values depend on a variety of criteria (for example the machine conditions) and can be higher or lower.</p>	Schnittwerte (Startwerte) Cutting parameters (Start)	f _{zm} *** mm	v _{max} *** mm	V _c Seite/Page ***
Schnittwerte (Startwerte) Cutting parameters (Start)	f _{zm} *** mm	v _{max} *** mm	V _c Seite/Page ***		

Info

Hinweisliste
Additional information

H01

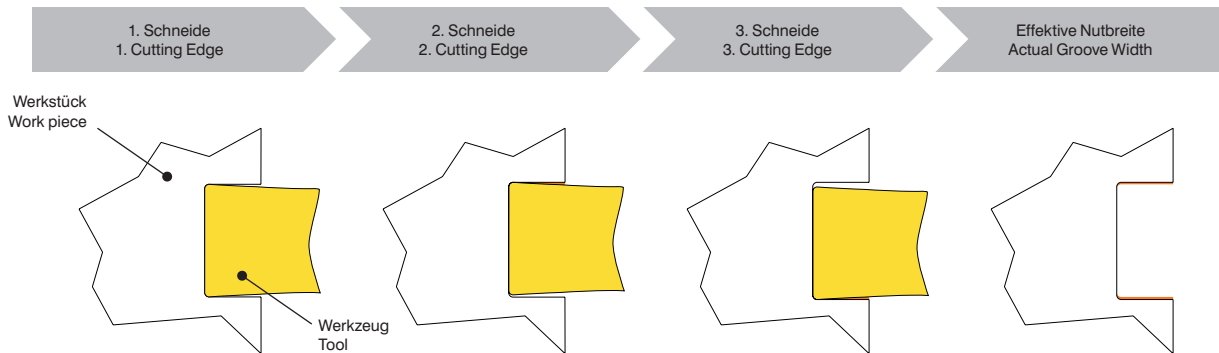


Bitte beachten Sie, dass zusätzlich zu der angegebenen Schneidenbreitentoleranz noch eine bauartbedingte Planlauftoleranz von bis zu 0,03 mm berücksichtigt werden muss.

Die effektive Nutbreite kann somit ggü. der Schneidenbreite um bis zu 0,03 mm breiter ausfallen.

Please note that a design inherent circular run-out tolerance of up to 0,03 mm must be considered in addition to the given cutting edge width tolerance.

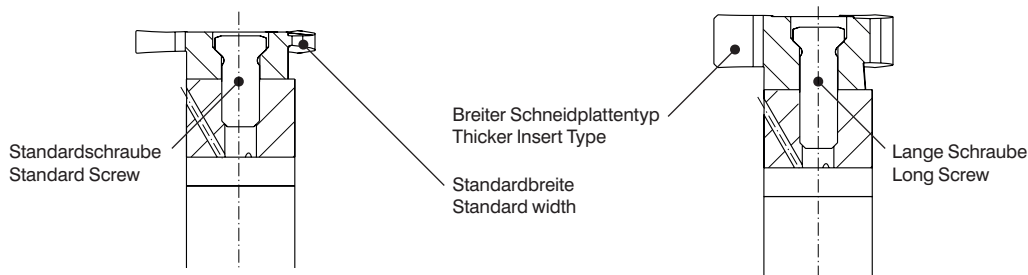
The actual groove width can be up to 0,03 mm wider than the given cutting edge width.



H02

Die mit den Fräseschäften ausgelieferte Standardschraube ist für diesen breiten Schneidplattentyp zu kurz.
Bitte im Bestellfall zusätzlich die längere Schraube mitbestellen.

The standard screw which is mounted on the standard milling cutter shanks is not long enough for this thicker insert type.
Please order the longer screw too in case of ordering this insert type.



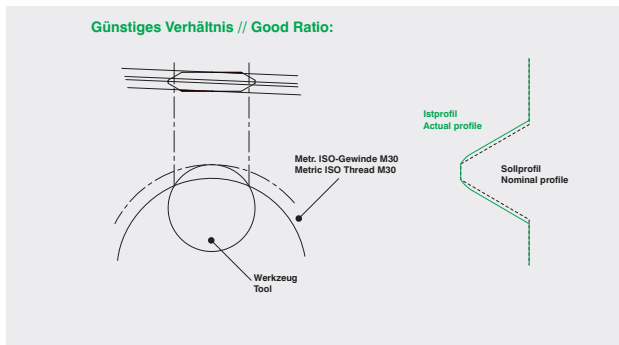
Aufnahmecode Connect code	Standardschraube Standard screw	Lange Schraube Long screw
UD*	U M4 x 12 T15F	U M4 x 16,6 T15F
VD*	V M5 x 12 T20T	V M5 x 16 T20T

Hinweisliste Additional information

H03

Beim Zirkularfräsen von Gewinden ist ein möglicher Vor- und Nachschnitt des Werkzeugs in den Gewindegängen zu berücksichtigen. Bitte achten Sie daher bei der Werkzeugauswahl darauf, dass der Schneidkreisdurchmesser des Werkzeugs im Verhältnis zum Kernlochdurchmesser des Gewindes ausreichend klein gewählt wird. Bei diesem Auswahlprozess ist auch die Steigung zu berücksichtigen.

Die folgende Illustration zeigt links ein günstiges und rechts ein ungünstiges Verhältnis zwischen Kernloch- und Werkzeugdurchmesser. Die roten Flächen stellen hierbei den Vor- bzw. Nachschnitt dar. Im Beispiel links ist das Istprofil nahe dem gewünschten Sollprofil:



Es gelten die Regeln:

Je größer der Kernlochdurchmesser, desto größer der mögl. Schneidkreis.
Je größer die Steigung, desto kleiner der mögl. Schneidkreis.

Die folgende Tabelle enthält eine exemplarische Übersicht des empf. max. Schneidkreisdurchmesser je Gewindegröße und Steigung:

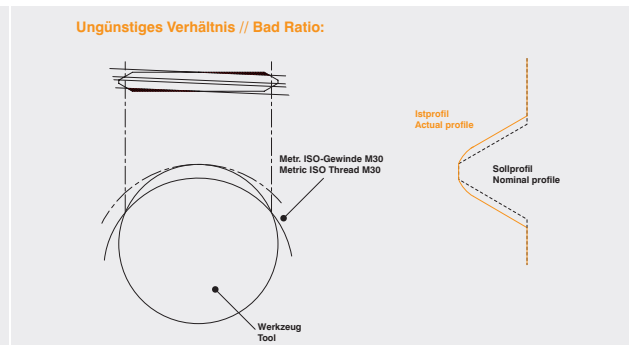
		Metr. ISO-Gewinde, Teilprofil // Metric ISO-Thread, partial profile										
		M12	M16	M20	M24	M27	M30	M36	M42	M48	M56	M60
Steigung // Pitch	1	10,0	14,0	18,0	22,0	25,0	28,0	34,0	40,0	45,0	53,0	57,0
	1,5	8,0	12,0	16,0	20,0	24,0	26,0	32,0	37,0	43,0	51,0	55,0
	2	7,0	10,0	14,0	18,0	22,0	24,0	30,0	35,0	40,0	48,0	52,0
	2,5	6,0	8,0	12,0	16,0	20,0	22,0	28,0	32,0	37,0	45,0	48,0
	3	-	6,0	10,0	14,0	18,0	20,0	26,0	30,0	36,0	43,0	47,0
	3,5	-	-	-	12,0	16,0	18,0	24,0	29,0	35,0	42,0	46,0
	4	-	-	-	-	-	-	22,0	27,0	32,0	39,0	43,0
	4,5	-	-	-	-	-	-	-	24,0	30,0	37,0	40,0
	5	-	-	-	-	-	-	-	22,0	27,0	34,0	37,0
	5,5	-	-	-	-	-	-	-	20,0	25,0	31,0	35,0
	6	-	-	-	-	-	-	-	19,0	23,0	29,0	32,0

Alle Maße in mm // Values in mm.

Unsere Schneidwerkzeuge für das Gewindefräsen weisen bereits eine Gewindeignung aus. Dieser Wert richtet sich bei den Teilprofilwerkzeugen nach der angegebenen kleineren Steigung. Die größere Steigung ist demnach erst in größeren Gewindedurchmessern realisierbar.

Thread milling by circular interpolation can cause thread profile violation. Please keep this possible profile violation in mind during the process of selecting a suitable tool. The tool diameter needs to be small enough compared to the core hole diameter. The pitch also needs to be considered here.

The following illustration shows a good ratio between core hole diameter and tool diameter on the left side and a bad ratio on the right side. The red areas indicate the profile violation. The left example would lead to an actual profile which is very close to the nominal profile:



Two general rules apply:

The bigger the core hole diameter is, the bigger the tool diam. can be.
The bigger the pitch is, the smaller the tool diam. should be.

The following table is an example showing the recommended maximum tool diameter in relation to the thread size and pitch:

A thread size recommendation is given on the catalog page next to every thread milling tool. In case of partial profile tools, this recommendation is based on the smaller pitch. The second (larger) pitch is possible in bigger diameters.

Info

Hinweisliste

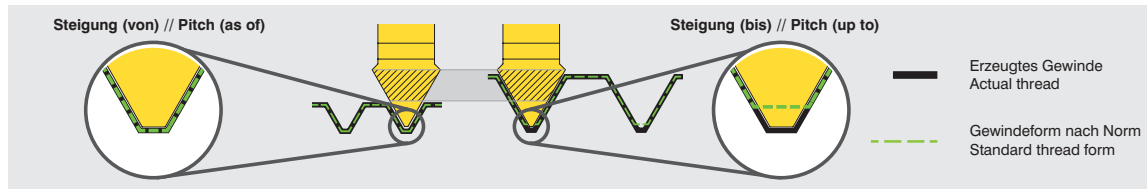
Additional information

H04

Bei den simmill Teilprofil-Gewindefrässchneidplatten für metrische ISO-Gewinde handelt es sich um Mehrbereichswerkzeuge, d.h. dass mit einem Werkzeug unterschiedliche Steigungen gefräst werden können.

Das Schneidwerkzeug ist dabei immer auf die angegebene „Steigung (von)“ ausgelegt, wodurch ein normgerechtes Gewinde beim Fertigen dieser Steigung entsteht.

Die ebenfalls angegebene „Steigung (bis)“ kann mit diesem Werkzeug ebenfalls gefertigt werden. Es entsteht hierbei jedoch ein - gegenüber der Norm - geringfügig tieferes Gewinde. Die geringfügig höhere Gewindetiefe ist i.d.R. akzeptabel, es muss jedoch immer der Einzelfall beurteilt werden.



Beispiel // Example

The simmill Groove Milling inserts with partial profile for metric ISO-threads are multi-purpose tools. This means that each insert is offering the possibility to machine different pitches.

The insert is always designed to meet the pitch given as „Pitch (as of)“: Machining this pitch will result in a standard conform thread form.

The given „Pitch (up to)“ can be machined too with this insert at the expense of standard conformity: The resulting thread will be slightly deeper than the standard. The deeper thread is usually acceptable, but the application and use needs to be evaluated.

H05

Je nach Anwendung und Werkstückmaterial, sollte bei der Nutzung von sechsschneidigen Fräs Werkzeugen und zur Reduzierung des Schnittdrucks, auf ein ausreichend großes Verhältnis zwischen Schneidkreis- und Bohrungsdurchmesser geachtet werden. Bei begrenzter Auswahlmöglichkeit ist im Zweifel das dreischneidige Werkzeug zu bevorzugen.

Dieses Beispiel zeigt (in identischen Bohrungsdurchmessern), links ein dreischneidiges und rechts ein sechsschneidiges Fräs-werkzeug mit identischen Schneidkreisdurchmessern: Die drei-schneidige Ausführung ist mit 2 Schneiden im Einsatz, während die sechsschneidige Ausführung mit bis zu 4 Scheiden im Einsatz ist.



Please choose a good ratio between the diameter of the Milling insert and the workpiece bore diameter, when using milling inserts with 6 cutting edges. This can reduce the cutting pressure, depending on the application and work piece material. In case of doubt, the three edged model could be the best choice.

This example shows a three edged milling insert on the left side and a six edged milling insert on the right side - both with equal sizes and shown in the same bore diameter: The three edged model is permanently using 2 cutting edged while the six edged model is using up to 4 cutting edges at the same time.

H06

Nachschnittregel für das Fräsen von metrischen ISO-Vollprofilgewinden

Bitte beachten Sie beim Fräsen metrischer ISO-Vollprofilgewinden mit simmill Werkzeugen die folgende Nachschnittregel (P = Steigung):

$P < 2 \text{ mm}$: max. 0,02 mm Nachschnitt/Flanke
 $P > 2 \text{ mm}$: max. $P/100$ Nachschnitt/Flanke

Recut rule for the milling of metric ISO full profile threads

Please note the following recut rule when milling metric ISO full profile threads with simmill tools (P=Pitch):

$P < 2 \text{ mm}$: max. 0,02 mm recut/flank
 $P > 2 \text{ mm}$: max. $P/100$ recut/flank

H07

ZEFP

Anzahl wirksamer Schneiden, umfangseitig
 Peripheral effective cutting edge count

ZEFF

Anzahl wirksamer Schneiden, stirnseitig
 Face effective cutting edge count

Mehrbereichs-Gewindefräswerkzeuge Multi Purpose Thread Milling Tools

SIMTEK Teilprofil-Gewindefräswerkzeuge für metrische ISO-Gewinde sind als Mehrbereichswerkzeuge ausgelegt: Alle Werkzeuge sind für eine Steigung ausgelegt, bieten aber auch die Möglichkeit größere Steigungen zu fertigen, wenn eine geringfügig größere Gewindetiefe akzeptiert werden kann. Vergleichen Sie hierzu bitte die Hinweise H03 (S./P. 647) und H04 (S./P. 648).

Dieser Tabelle können Sie entnehmen, auf welche Steigung das Werkzeug ausgelegt ist (grün hinterlegt) und welche Steigungen ebenfalls möglich sind (dunkelgrau hinterlegt). Der Tabellenwert entspricht dabei dem Gewinde-Nenndurchmesser (mm) ab dem das Werkzeug einsetzbar ist.

SIMTEK thread milling inserts with metric ISO partial profile are designed as multi-purpose-tools. This means that every tool is designed to provide standard conformity for one pitch and offers the possibility to machine higher pitches too at the expense of standard conformity: The thread will become slightly deeper than the standard. Please read notes H03 (S./P. 647) and H04 (S./P. 648).





This table shows the range of possible pitches for every item. The pitch with a green background indicates that the tool is designed for this pitch. Pitches with a dark grey background are machinable too. The table value indicates the recommended minimum nominal thread diameter (mm).

	Steigung (mm) // Pitch (mm)																															
	0,50	0,60	0,70	0,80	0,90	1,00	1,10	1,20	1,25	1,30	1,40	1,50	1,60	1,70	1,75	1,80	1,90	2,00	2,50	2,75	3,00	3,50	3,75	4,00	4,50	5,00	5,50	6,00	6,50			
MA3.MT15.01.15.06 M	>7,0	>7,5	>7,5	>8,0	>8,0	>8,0	>8,5	>8,5	>8,5	>8,5	>9,0	>9,0																				
MA3.MT15.01.25.08 M	>9,0	>9,5	>9,5	>10,0	>10,0	>10,0	>10,5	>10,5	>10,5	>11,0	>11,0	>11,0																				
MA3.MT20.01.25.08 M						>10,0	>10,5	>10,5	>10,5	>11,0	>11,0	>11,0	>11,5	>11,5	>11,5	>11,5	>11,5	>12,0														
MA3.MT15.01.15.250 M	>7,0	>7,5	>7,5	>8,0	>8,0	>8,0	>8,5	>8,5	>8,5	>8,5	>9,0	>9,0																				
MA3.MT15.01.25.312 M	>9,0	>9,5	>9,5	>10,0	>10,0	>10,0	>10,5	>10,5	>10,5	>11,0	>11,0																					
MA3.MT20.01.25.312 M						>10,0	>10,5	>10,5	>10,5	>11,0	>11,0	>11,0	>11,5	>11,5	>11,5	>11,5	>11,5	>12,0														
P06.0510.01.10 M						>12,0	>13,0	>13,0	>13,0	>13,0	>13,0	>14,0	>14,0	>14,0																		
P06.0720.01.10 M						>13,0	>13,0	>13,0	>13,0	>13,0	>13,0	>14,0	>14,0	>14,0	>14,0	>14,0	>14,5	>15,0														
P06.0720.01.12 M						>14,0	>14,5	>14,5	>15,0	>15,0	>15,0	>15,0	>15,5	>15,5	>15,5	>16,0	>16,0	>16,0														
P06.0815.01.11 M												>15,0	>15,0	>15,0	>15,0	>15,0	>15,5	>16,0	>18,0	>18,0												
P06.2530.01.11 M																	>16,0	>18,0	>18,0	>19,0												
P12.0510.01 M						>14,0	>14,5	>14,5	>15,0	>15,0	>15,0	>15,0	>15,5	>15,5	>16,0																	
P12.0720.01 M						>14,0	>14,5	>14,5	>15,0	>15,0	>15,0	>15,0	>15,5	>15,5	>16,0	>16,0	>16,0	>16,0														
P12.0815.01 M												>15,0	>15,5	>15,5	>16,0	>16,0	>16,0	>17,0	>17,0													
P12.2530.01 M																	>16,0	>17,0	>17,0	>18,0												
S06.0510.01.12 M						>15,0	>15,0	>15,0	>15,0	>15,0	>15,5	>16,0	>16,0	>16,0																		
S06.0720.01.12 M						>15,0	>15,0	>15,0	>15,0	>15,5	>15,5	>16,0	>16,0	>17,0	>17,0	>17,0	>17,0															
S06.0815.01.13 M												>17,0	>17,0	>17,0	>17,0	>17,5	>18,0	>18,0	>20,0	>21,0												
S06.2530.01.13 M																	>18,0	>20,0	>21,0	>21,0												
S16.0510.01 M						>18,0	>18,5	>19,0	>19,0	>19,0	>19,0	>20,0	>20,0	>20,0	>20,0																	
S16.0720.01 M						>18,0	>18,5	>19,0	>19,0	>19,0	>19,0	>20,0	>20,0	>20,0	>20,0	>20,0	>20,0	>21,0														
S16.0815.01 M												>20,0	>20,0	>20,0	>20,0	>20,0	>20,0	>21,0	>21,0	>22,0												
S16.2530.01 M																	>21,0	>22,0	>22,0													
U06.0720.01.18 M						>20,5	>20,5	>21,0	>21,0	>21,0	>21,5	>21,5	>21,5	>22,0	>22,0	>22,0	>22,5	>22,5														
U06.2535.01.18 M																	>22,5	>23,5	>24,0	>24,0	>25,0											
U18.0510.01 M						>21,0	>21,0	>21,0	>21,0	>21,0	>22,0	>22,0	>22,0	>22,0																		
U18.0720.01 M						>21,0	>21,0	>21,0	>21,0	>21,0	>22,0	>22,0	>22,0	>22,0	>22,0	>22,0	>23,0	>23,0														
U18.0815.01 M												>22,0	>22,0	>22,0	>22,0	>22,0	>23,0	>23,0	>24,0	>24,0												
U18.1020.01 M																	>23,0	>24,0	>24,0	>24,0	>25,0	>26,0										
U18.1325.01 M																	>23,0	>24,0	>24,0	>24,0												
U18.1630.01 M																	>24,0	>24,0	>24,0	>25,0	>26,0	>26,0	>27,0	>28,0								
U18.1835.01 M																		>24,0	>25,0	>26,0	>26,0	>27,0	>28,0	>28,0								
U18.2535.01 M																	>23,0	>24,0	>24,0	>24,0	>25,0											
V06.0720.01.22 M						>25,0	>25,0	>25,0	>25,0	>25,0	>25,0	>25,0	>26,0	>26,0	>26,0	>27,0	>27,0	>27,0														
V06.2545.01.22 M																	>27,0	>28,0	>28,0	>29,0	>30,0	>30,0	>30,0	>31,0								
V06.1525.01.28 M												>32,0	>32,0	>32,0	>32,0	>33,0	>33,0	>33,0	>34,0													
V06.3050.01.28 M																	>34,0	>35,0	>35,0	>36,0	>36,0	>37,0	>38,0	>39,0								
V22.0720.01 M						>25,0	>25,0	>25,0	>25,0	>25,0	>26,0	>26,0	>26,0	>26,0	>27,0	>27,0	>27,0															
V22.0815.01 M												>26,0	>26,0	>26,0	>26,0	>27,0	>27,0	>28,0	>28,0													
V22.1020.01 M																	>27,0	>28,0	>28,0	>29,0	>30,0	>30,0										
V22.1630.01 M																	>28,0	>28,0	>29,0	>30,0	>30,0	>30,0	>31,0	>32,0								
V22.2140.01 M																		>30,0	>30,0	>30,0	>31,0	>32,0	>33,0	>34,0								
V22.2445.01 M																		>30,0	>30,0	>30,0	>31,0	>32,0	>33,0	>34,0	>34,0							
V22.2545.01 M																	>28,0	>28,0	>29,0	>30,0	>30,0	>30,0	>31,0									
V28.0720.01 M						>31,0	>31,0	>31,0	>31,0	>31,0	>32,0	>32,0	>32,0	>32,0	>33,0	>33,0																
V28.1525.01 M												>32,0	>32,0	>32,0	>32,0	>33,0	>33,0	>34,0														
V28.3050.01 M																	>34,0	>35,0	>35,0	>36,0	>36,0	>37,0	>38,0	>39,0								
V28.5060.01 M																			>37,0	>38,0	>39,0	>39,0	>40,0									

simmill AX
simmill PMX
simmill PX
simmill SX
simmill UX
simmill VX
simmill H2
simmill K2
simmill MX
simmill OS
Index

Info

Legende
Legend

- SP** Schneidwerkzeug aus Hartmetall // Carbide insert // Outils coupants en carbure de tungstène // Inserto in metallo duro
HM Inserto de carburo // Karbür kesici uç
- TW** Trägerwerkzeug aus Hartmetall // Carbide toolholder // Porte-outils en carbure // Porta inserto in metallo duro
HM Porta-herramientas de carburo // Karbür tutucu
- TW** Trägerwerkzeug aus Schwermetall // Heavy metal toolholder // Porte-outils en métal lourd // Porta inserto in Metallo pesante
SM Porta-herramientas de metal pesado // Ağır metal tutucu
- TW** Trägerwerkzeug aus Stahl // Steel toolholder // Porte-outils en acier // Porta inserto in acciaio
ST Porta-herramientas de acero // Çelik tutucu
- R** Rechts wie gezeichnet // Right hand version shown, left hand version inversely // A droite comme présenté // In figura utensile destro
 Modelo derecho // Sağ model
-  Innere Kühlmittelzufuhr // Through coolant // Refroidissement interne // Lubrificazione interna
 Con refrigeración interna // İçten soğutmalı
- LM** Speziell für Leichtmetall // For light-alloys // Pour métaux légers // Per metallo leggero
 Para aleaciones ligeras // Hafif alaşımlı metaller
-  Nur für die Außenbearbeitung geeignet // Only suitable for external applications // Seulement pour opérations extérieures
 Solo per lavorazione esterna // Soló para mecanizado externo // Dış çaplar için
-  Nur für die Innenbearbeitung geeignet // Only suitable for internal applications // Seulement pour opérations intérieures
 Solo per lavorazione interna // Soló para mecanizado interno // İç çaplar için
-  Schwingungsgedämpft // Anti-vibration // Anti vibration // Antivibrante // Anti-vibración // Anti vibrasyon

Index

simmill Produktverzeichnis
simmill Product List

Artikelnr. // Part Nr.	S/P	Artikelnr. // Part Nr.	S/P	Artikelnr. // Part Nr.	S/P	Artikelnr. // Part Nr.	S/P	Artikelnr. // Part Nr.	S/P
A04.0010.01.03.00 YR	636	M14.0437.02 GR	619	M14.MT60.02 EM R	623	M81.0100.10 R	616	MA3.UN36.02.10.06 AM	448
A04.0025.02.06.00 YR	636	M14.0475.02 GL	619	M14.MT60.02 IM R	624	MA3.050.15.06.00 AG	443	MA3.UN40.02.08.04 AM	448
A04.0045.04.10.05 YR	636	M14.0475.02 GR	619	M14.UN04.02 IM R	626	MA3.060.15.06.00 AG	443	MA3.UN40.C.02.08.04 AM	448
A04.0045.06.10.05 YR	636	M14.0500.02 GR	619	M14.UN04.02 MR	625	MA3.070.15.06.00 AG	443	MA3.UN44.02.08.04 AM	448
A04.0095.06.22.05 YR	636	M14.0500.250 VR	621	M14.UN06.02 IM R	626	MA3.070.25.08.00 AG	443	MA4.100.20.10.05 AV	444
A04.0095.09.22.05 YR	636	M14.0515.02 GL	619	M14.UN06.02 MR	625	MA3.080.15.06.00 AG	443	MA4.150.16.08.07 AV	444
A04.0145.10.32.05 YR	636	M14.0515.02 GR	619	M14.UN08.02 IM R	626	MA3.080.25.08.00 AG	443	MA4.150.20.10.07 AV	444
A04.0145.15.32.05 YR	636	M14.0815.01 ML	622	M14.UN08.02 MR	625	MA3.090.15.06.00 AG	443	MA4.200.16.08.10 AV	444
A04.0145.20.32.05 YR	636	M14.0815.01 MR	622	M14.UN10.02 IM R	626	MA3.090.25.08.00 AG	443	MA4.200.20.10.10 AV	444
A04.0195.15.39.05 YR	636	M14.1020.01 ML	622	M14.UN10.02 MR	625	MA3.100.04.04.05 AV	444	MA4.250.20.10.12 AV	444
A04.0195.20.39.05 YR	636	M14.1020.01 MR	622	M14.UN11.02 IM R	626	MA3.100.04.06.00 AS	453	MA4.300.20.10.15 AV	444
A04.0195.25.39.05 YR	636	M14.1105.54 FL	620	M14.UN11.02 MR	625	MA3.100.06.06.05 AV	444	MA4.BS12.C.02.30.10 AM	450
A07.0245.20.52.05 YR	636	M14.1105.54 FR	620	M14.UN12.02 IM R	626	MA3.100.15.06.00 AG	443	MA4.BS14.C.02.25.08 AM	450
A07.0245.25.52.05 YR	636	M14.1307.54 FL	620	M14.UN12.02 MR	625	MA3.100.25.08.00 AG	443	MA4.BS16.02.30.10 AM	450
A07.0295.20.62.05 YR	636	M14.1307.54 FR	620	M14.UN14.02 IM R	626	MA3.150.06.06.07 AV	444	MA4.BS16.C.02.16.08 AM	450
A07.0295.20.62.05 YR	636	M14.1308.54 FL	620	M14.UN14.02 MR	625	MA3.150.07.08.00 AS	453	MA4.BS18.02.25.08 AM	450
A07.0295.25.62.05 YR	636	M14.1308.54 FR	620	M14.UN16.02 IM R	626	MA3.150.15.06.00 AG	443	MA4.BS18.C.02.16.06 AM	450
A07.0295.30.62.05 YR	636	M14.1535.01 ML	622	M14.UN16.02 MR	625	MA3.150.25.08.00 AG	443	MA4.BS19.P.02.20.10 AM	451
A07.0345.25.69.20 YR	636	M14.1535.01 MR	622	M14.UN18.02 IM R	626	MA3.200.07.08.00 AS	453	MA4.BS19.P.02.30.12 AM	451
A07.0345.30.69.20 YR	636	M14.1609.54 FL	620	M14.UN18.02 MR	625	MA3.200.10.12.00 AS	453	MA4.BS20.02.16.08 AM	450
A07.0345.40.69.20 YR	636	M14.1609.54 FR	620	M14.UN20.02 IM R	626	MA3.200.25.08.00 AG	443	MA4.BS22.02.16.06 AM	450
D07.0345.20.07 YR	637	M14.1610.54 FL	620	M14.UN20.02 MR	625	MA3.250.10.12.00 AS	453	MA4.BS26.02.16.06 AM	450
D07.0395.20.08 YR	637	M14.1610.54 FR	620	M80.0063.05 L	614	MA3.300.10.12.00 AS	453	MA4.BS28.P.02.16.06 AM	451
D07.0445.20.09 YR	637	M14.1812.54 FL	620	M80.0063.05 R	614	MA3.300.13.16.00 AS	453	MA4.BS28.P.02.16.08 AM	451
D07.A07.30 HM	635	M14.1812.54 FR	620	M80.0063.05.07 L	614	MA3.300.16.16.00 AS	453	MA4.MT04.01.05.03 AM	446
D10.0495.20.10 YR	637	M14.2115.54 FL	620	M80.0063.05.07 R	614	MA3.400.13.16.00 AS	453	MA4.MT04.01.06.03 AM	446
D10.0595.20.12 YR	637	M14.2115.54 FR	620	M80.0063.05.07.IC L	614	MA3.400.16.16.00 AS	453	MA4.MT04.C.01.05.03 AM	447
D10.0695.20.14 YR	637	M14.2140.01 ML	622	M80.0063.05.07.IC R	614	MA3.400.19.16.00 AS	453	MA4.MT04.C.01.06.03 AM	447
D10.A07.35 HM	635	M14.2140.01 MR	622	M80.0063.05.IC L	614	MA3.4545.02.15.06 AF	452	MA4.MT05.01.07.03 AM	446
D10.A07.50 HM	635	M14.2445.01 ML	622	M80.0063.05.IC R	614	MA3.4545.02.15.250 AF	452	MA4.MT05.C.01.07.03 AM	447
M14.0117.01 GL	619	M14.2445.01 MR	622	M80.0080.08 L	614	MA3.4545.02.25.06 AF	452	MA4.MT06.01.08.03 AM	446
M14.0117.01 GR	619	M14.2616.54 FL	620	M80.0080.08 R	614	MA3.4545.02.25.08 AF	452	MA4.MT06.C.01.08.03 AM	447
M14.0130.01 GL	619	M14.2616.54 FR	620	M80.0080.08.07 L	614	MA3.4545.02.25.250 AF	452	MA4.MT07.01.09.05 AM	446
M14.0130.01 GR	619	M14.2617.54 FL	620	M80.0080.08.07 R	614	MA3.4545.02.25.312 AF	452	MA4.MT07.02.16.06 AM	449
M14.0157.01 GL	619	M14.2617.54 FR	620	M80.1044.03.IC	613	MA3.4545.02.35.08 AF	452	MA4.MT07.02.20.08 AM	449
M14.0157.01 GR	619	M14.2750.01 ML	622	M80.2480.05 L	614	MA3.4545.02.35.312 AF	452	MA4.MT07.C.01.09.05 AM	447
M14.0160.01 GL	619	M14.2750.01 MR	622	M80.2480.05 R	614	MA3.500.16.16.00 AS	453	MA4.MT07.01.10.05 AM	446
M14.0160.01 GR	619	M14.3118.54 FL	620	M80.2480.05.07 L	614	MA3.500.19.16.00 AS	453	MA4.MT08.C.01.10.05 AM	447
M14.0185.02 GL	619	M14.3118.54 FR	620	M80.2480.05.07 R	614	MA3.500.22.16.00 AS	453	MA4.MT08.C.02.12.06 AM	449
M14.0185.02 GR	619	M14.3260.01 ML	622	M80.2539.02	613	MA3.600.19.16.00 AS	453	MA4.MT10.01.12.05 AM	446
M14.0200.02 GL	619	M14.3260.01 MR	622	M80.2539.02.07	613	MA3.600.22.16.00 AS	453	MA4.MT10.01.15.05 AM	446
M14.0200.02 GR	619	M14.4060.01 ML	622	M80.2539.02.IC	613	MA3.600.25.16.00 AS	453	MA4.MT10.02.16.06 AM	449
M14.0215.02 GL	619	M14.4060.01 MR	622	M80.2544.03	613	MA3.800.22.16.00 AS	453	MA4.MT10.02.20.10 AM	449
M14.0215.02 GR	619	M14.4120.54 FL	620	M80.2544.03.07	613	MA3.BS20.C.02.16.06 AM	450	MA4.MT10.02.25.08 AM	449
M14.0239.02 GL	619	M14.4120.54 FR	620	M80.2544.03.IC	613	MA3.BS24.C.02.10.06 AM	450	MA4.MT10.C.01.12.05 AM	447
M14.0239.02 GR	619	M14.4125.54 FL	620	M80.C344.60.03	615	MA3.BS26.02.16.06 AM	450	MA4.MT10.C.01.15.05 AM	447
M14.0250.02 GL	619	M14.4125.54 FR	620	M80.C344.60.03.07	615	MA3.BS28.02.10.06 AM	450	MA4.MT10.C.02.16.06 AM	449
M14.0250.02 GR	619	M14.5130.61 FL	620	M80.C344.60.03.07.IC	615	MA3.BS32.02.10.06 AM	450	MA4.MT12.02.30.10 AM	449
M14.0250.125 VR	621	M14.5130.61 FR	620	M80.C344.60.03.IC	615	MA3.BS32.C.02.08.04 AM	450	MA4.MT12.C.02.16.06 AM	449
M14.0265.02 GL	619	M14.MT15.02 EM R	623	M80.C450.40.04	615	MA3.BS40.C.02.08.04 AM	450	MA4.MT15.C.02.20.08 AM	449
M14.0265.02 GR	619	M14.MT15.02 IM R	624	M80.C450.40.04.07	615	MA3.MT02.01.02.03 AM	446	MA4.MT17.C.02.30.10 AM	449
M14.0300.02 GL	619	M14.MT20.02 EM R	623	M80.C450.40.04.07.IC	615	MA3.MT03.01.04.03 AM	446	MA4.UN14.C.02.25.08 AM	448
M14.0300.02 GR	619	M14.MT20.02 IM R	624	M80.C450.40.04.IC	615	MA3.MT03.01.05.03 AM	446	MA4.UN16.C.02.25.06 AM	448
M14.0300.150 VR	621	M14.MT25.02 EM R	623	M80.C563.40.05	615	MA3.MT03.02.08.04 AM	449	MA4.UN18.C.02.10.06 AM	448
M14.0315.02 GL	619	M14.MT30.02 EM R	623	M80.C563.40.05.07	615	MA3.MT05.02.10.06 AM	449	MA4.UN20.02.30.08 AM	448
M14.0315.02 GR	619	M14.MT30.02 IM R	624	M80.C563.40.05.07.IC	615	MA3.MT05.C.02.08.04 AM	449	MA4.UN20.C.02.10.06 AM	448
M14.0318.02 GL	619	M14.MT35.02 EM R	623	M80.C563.40.05.IC	615	MA3.MT06.C.02.09.04 AM	449	MA4.UN28.02.10.06 AM	448
M14.0318.02 GR	619	M14.MT35.02 IM R	624	M80.C675.50.07	615	MA3.MT07.C.02.10.06 AM	449	MH2.150.005 GG	604
M14.0350.02 GL	619	M14.MT40.02 EM R	623	M80.C675.50.07.07	615	MA3.MT15.01.15.06 AM	446	MH2.150.020 GG	604
M14.0350.02 GR	619	M14.MT40.02 IM R	624	M80.C675.50.07.07.IC	615	MA3.MT15.01.15.250 AM	446	MH2.157.020 GG	604
M14.0400.02 GL	619	M14.MT45.02 EM R	623	M80.C675.50.07.IC	615	MA3.MT15.01.25.08 AM	446	MH2.200.005 GG	604
M14.0400.02 GR	619	M14.MT45.02 IM R	624	M81.0063.05 L	616	MA3.MT15.01.25.312 AM	446	MH2.200.020 GG	604
M14.0400.200 VR	621	M14.MT50.02 EM R	623	M81.0063.05 R	616	MA3.MT20.01.25.08 AM	446	MH2.239.020 GG	604
M14.0415.02 GL	619	M14.MT50.02 IM R	624	M81.0080.08 L	616	MA3.MT20.01.25.312 AM	446	MH2.250.005 GG	604
M14.0415.02 GR	619	M14.MT55.02 EM R	623	M81.0080.08 R	616	MA3.UN24.C.02.10.06 AM	448	MH2.250.020 GG	604
M14.0437.02 GL	619	M14.MT55.02 IM R	624	M81.0100.10 L	616	MA3.UN32.C.02.08.04 AM	448	MH2.300.005 GG	604

Index

simmill Produktverzeichnis
simmill Product List

Artikelnr. // Part Nr.	S/P	Artikelnr. // Part Nr.	S/P	Artikelnr. // Part Nr.	S/P	Artikelnr. // Part Nr.	S/P	Artikelnr. // Part Nr.	S/P
MH2.300.040 GG	604	MM4.12.0650.25 GR	628	P10.0200.02 G	493	PM7.0110.00 G	480	S14.1208.29 A HM	508
MH2.318.020 GG	604	MM4.12.0650.40 GL	628	P10.0250.02 G	493	PM7.MT.040.022.02 M	483	S14.1208.29 B HM	510
MH2.350.020 GG	604	MM4.12.0650.40 GR	628	P10.0407.02 M	501	PM7.MT.0405.01 M	482	S14.1208.42 A HM	508
MH2.350.040 GG	604	MM4.82.0063.22.06	617	P10.0510.02 M	501	PM7.MT.045.024.02 M	483	S14.1208.42 B HM	510
MH2.400.020 GG	604	MM4.82.0080.27.06	617	P10.0813.19 M	503	PM7.MT.050.027.02 M	483	S14.1208.56 A HM	508
MH2.400.040 GG	604	MM4.82.0080.27.08	617	P10.0815.02 M	501	PM7.MT.060.032.02 M	483	S14.1208.56 B HM	510
MH2.475.020 GG	604	MM4.82.0080.27.10	617	P10.0917.02 M	501	PM7.MT.070.038.02 M	483	S14.1209.42 A HM	508
MH2.500.020 GG	604	MM4.82.0100.32.06	617	P10.1006.15 AST	486	PM8.0030.00 S	481	S14.1209.42 B HM	510
MH2.500.040 GG	604	MM4.82.0100.32.08	617	P10.1006.15 BST	488	PM8.0040.00 S	481	S14.1308.25 A ST	509
MH2.80.0100.06.15.IC R	603	MM4.82.0100.32.10	617	P10.1020.02 M	501	PM8.0050.00 S	481	S14.1325.02 M	522
MH2.80.0100.06.20.IC R	603	MM4.82.0125.40.06	617	P10.1206.15 B ST	488	PM8.0060.00 S	481	S14.1608.16 A ST	509
MH2.80.0100.06.25.IC R	603	MM4.82.0125.40.08	617	P10.1206.21 A HM	485	PM8.0070.00 S	481	S14.1608.16 B ST	511
MH2.80.0100.06.30.IC R	603	MM4.82.0125.40.10	617	P10.1206.21 B HM	487	PM8.0080.00 S	481	S14.1609.33 A HM	508
MH2.80.0100.06.40.IC R	603	MM4.82.0125.40.12	617	P10.1206.30 A HM	485	PM8.0090.00 S	481	S14.1609.33 B HM	510
MH2.80.0102.06.15.IC R	603	MM4.82.0160.40.06	617	P10.1206.30 B HM	487	PM8.0100.00 S	481	S14.1630.02 M	522
MH2.80.0102.06.20.IC R	603	MM4.82.0160.40.08	617	P10.1206.42 A HM	485	PM8.MT.0510.01 M	482	S14.ER11.08.16	512
MH2.80.0102.06.25.IC R	603	MM4.82.0160.40.10	617	P10.1206.42 B HM	487	PM8.MT.075.041.02 M	483	S14.ER11.08.16.B	512
MH2.80.0102.06.30.IC R	603	MM4.82.0160.40.12	617	P10.1207.30 A HM	485	PM8.MT.080.043.02 M	483	S14.ER16.08.22	512
MH2.80.0102.06.40.IC R	603	MM4.82.0200.50.06	617	P10.1207.30 B HM	487	PM8.MT.100.054.02 M	483	S14.ER16.08.22.B	512
MK2.A.0110.01 GR	609	MM4.83.0100.27.06 R	618	P10.1325.02 M	501	PM9.0030.00.11 S	481	S14.ER16.08.22.C	512
MK2.A.0130.01 GR	609	MM4.83.0100.27.08 R	618	P10.1606.12 A ST	486	PM9.0040.00.11 S	481	S14.ER20.08.22	512
MK2.A.0160.01 GR	609	MM4.83.0100.27.10 R	618	P10.1606.12 B ST	488	PM9.0050.00.11 S	481	S14.ER20.08.22.B	512
MK2.A.0185.02 GR	609	MOS.STA.B10.080	632	P10.1607.25 A HM	485	PM9.0100.00 S	481	S16.0011.22 V	519
MK2.A.0215.02 GR	609	MOS.STK.A04.A	633	P10.1607.25 B HM	487	S06.0150.02.16 G	515	S16.0100.40 C	518
MK2.A.0265.02 GR	609	MOS.STK.A06.A	633	P10.4545.35 F	505	S06.0150.020.16 GY	517	S16.0117.00 G	514
MK2.A.0315.02 GR	609	MOS.STK.D14.A	634	P10.ER11.06.16	489	S06.0200.02.16 G	515	S16.0142.00 G	514
MK2.A.80.0039.06.04 R	607	P06.0150.02.12 G	495	P10.ER11.06.16.B	489	S06.0200.020.16 GY	517	S16.0150.02 G	514
MK2.A.80.0039.06.04.IC R	607	P06.0150.020.12 GY	496	P12.0005.10 V	498	S06.0250.02.16 G	515	S16.0157.02 G	514
MK2.A.80.0039.06.06 R	607	P06.0200.02.12 G	495	P12.0015.15 V	498	S06.0250.020.16 GY	517	S16.0160.01 G	516
MK2.A.80.0039.06.06.IC R	607	P06.0200.020.12 GY	496	P12.0010.20 V	498	S06.0510.01.12 M	520	S16.0200.02 G	514
MK2.A.80.0050.08.04 R	607	P06.0510.01.10 M	499	P12.0011.22 V	498	S06.0720.01.12 M	520	S16.0200.42 C	518
MK2.A.80.0050.08.04.IC R	607	P06.0720.01.10 M	499	P12.0015.30 V	498	S06.0815.01.13 M	520	S16.0239.02 G	514
MK2.A.80.0050.08.06 R	607	P06.0720.01.12 M	499	P12.0031.62 V	498	S06.1118.14.14 M	523	S16.0250.02 G	514
MK2.A.80.0050.08.06.IC R	607	P06.0813.19.10 M	502	P12.0047.94 V	498	S06.1423.11.14 M	523	S16.0250.42 C	518
MK2.A.80.1039.06.04.IC R	606	P06.0813.19.12 M	502	P12.0110.00 G	491	S06.1515.02.14 F	525	S16.0318.02 G	514
MK2.A.80.2539.06.04 R	606	P06.0815.01.11 M	499	P12.0110.40 C	492	S06.2020.02.14 F	525	S16.0510.01 M	521
MK2.A.80.2539.06.04.IC R	606	P06.1118.14.12 M	502	P12.0130.01 G	491	S06.2530.01.13 M	520	S16.0720.01 M	521
MK2.A.80.2539.06.06 R	606	P06.1515.02.10 F	504	P12.0130.41 C	492	S06.3030.02.14 F	525	S16.0815.01 M	521
MK2.A.80.2539.06.06.IC R	606	P06.2020.02.11 F	504	P12.0150.02 G	494	S06.4545.02.14 F	525	S16.1118.14 M	524
MK2.A.81.0063.12.04 R	608	P06.2530.01.11 M	499	P12.0150.42 C	497	S06.5230.020.16 Y	527	S16.1423.11 M	524
MK2.A.81.0063.12.06 R	608	P06.3030.02.10 F	504	P12.0157.02 G	494	S14.0.500.08.29 A HM	508	S16.2530.01 M	521
MK2.A.81.0080.16.04 R	608	P06.4545.02.10 F	504	P12.0160.01 G	491	S14.0.500.08.29 B HM	510	S16.4545.02 F	526
MK2.A.81.0080.16.06 R	608	P06.ST25.020.12 Y	506	P12.0160.41 C	492	S14.0.500.08.42 A HM	508	S16.4545.45 F	526
MK2.A.81.0100.20.04 R	608	P09.4545.02 F	505	P12.0200.02 G	494	S14.0.500.08.42 B HM	510	U06.0110.000.18 G	534
MK2.A.81.0100.20.06 R	608	P10.0.500.06.21 A HM	485	P12.0200.42 C	497	S14.0.500.08.56 A HM	508	U06.0130.000.18 G	534
MM4.06.0320.02 GL	627	P10.0.500.06.21 B HM	487	P12.0239.02 G	494	S14.0.500.08.56 B HM	510	U06.0150.010.18 G	537
MM4.06.0320.02 GR	627	P10.0.500.06.30 A HM	485	P12.0250.02 G	494	S14.0.500.09.42 A HM	508	U06.0150.010.20 G	538
MM4.06.0320.20 GL	628	P10.0.500.06.30 B HM	487	P12.0250.42 C	497	S14.0.500.09.42 B HM	510	U06.0160.000.18 G	534
MM4.06.0320.20 GR	628	P10.0.500.06.42 A HM	485	P12.0300.02 G	494	S14.0.625.08.16 A ST	509	U06.0200.020.18 G	537
MM4.08.0430.02 GL	627	P10.0.500.06.42 B HM	487	P12.0510.01 M	500	S14.0.625.08.16 B ST	511	U06.0200.020.18 GY	541
MM4.08.0430.02 GR	627	P10.0.500.07.30 A HM	485	P12.0720.01 M	500	S14.0.625.09.33 A HM	508	U06.0200.020.20 G	538
MM4.08.0430.20 GL	628	P10.0.500.07.30 B HM	487	P12.0813.19 M	503	S14.0.625.09.33 B HM	510	U06.0200.020.20 GY	542
MM4.08.0430.20 GR	628	P10.0.625.06.12 A ST	486	P12.0815.01 M	500	S14.0100.00 G	513	U06.0250.020.18 G	537
MM4.08.0430.25 GL	628	P10.0.625.06.12 B ST	488	P12.1118.14 M	503	S14.0100.01 G	513	U06.0250.020.18 GY	541
MM4.08.0430.25 GR	628	P10.0.625.07.25 A HM	485	P12.1423.11 M	503	S14.0117.00 G	513	U06.0250.020.20 G	538
MM4.10.0545.02 GL	627	P10.0.625.07.25 B HM	487	P12.2530.01 M	500	S14.0142.00 G	513	U06.0250.020.20 GY	542
MM4.10.0545.02 GR	627	P10.0070.00 Z	490	P12.4545.35 F	505	S14.0150.02 G	513	U06.0300.020.18 G	537
MM4.10.0545.20 GL	628	P10.0080.00 Z	490	PM0.0.375.05.10 A ST	478	S14.0157.02 G	513	U06.0300.020.18 GY	541
MM4.10.0545.20 GR	628	P10.0090.00 Z	490	PM0.0805.17 A HM	478	S14.0200.02 G	513	U06.0300.020.20 G	538
MM4.10.0545.25 GL	628	P10.0100.00 G	490	PM0.0805.25 A HM	478	S14.0239.02 G	513	U06.0300.020.20 GY	542
MM4.10.0545.25 GR	628	P10.0100.01 G	493	PM0.0805.35 A HM	478	S14.0250.02 G	513	U06.0720.01.18 M	547
MM4.10.0545.40 GL	628	P10.0110.00 G	490	PM0.1005.10 A ST	479	S14.0510.02 M	522	U06.0815.02.18 M	545
MM4.10.0545.40 GR	628	P10.0130.01 G	490	PM7.0050.00 S	481	S14.0815.02 M	522	U06.1020.02.18 M	545
MM4.12.0650.02 GL	627	P10.0150.02 G	493	PM7.0090.00 G	480	S14.0917.02 M	522	U06.1630.02.18 M	545
MM4.12.0650.02 GR	627	P10.0157.00 G	493	PM7.0100.00 G	480	S14.1008.17 A ST	509	U06.1835.02.18 M	545
MM4.12.0650.25 GL	628	P10.0160.01 G	490	PM7.0100.00 S	481	S14.1020.02 M	522	U06.2535.01.18 M	547

Index

simmill Produktverzeichnis
simmill Product List

Artikelnr.// Part Nr.	S/P	Artikelnr.// Part Nr.	S/P	Artikelnr.// Part Nr.	S/P	Artikelnr.// Part Nr.	S/P	Artikelnr.// Part Nr.	S/P
U06.4545.020.18 F	553	U18.1009.17 A ST	530	V06.0060.000.40 G	600	V06.1020.02.22 M	575	V22.0185.02 G	565
U06.4545.050.15 F	553	U18.1020.01 M	548	V06.0080.000.37 G	600	V06.1525.01.28 M	593	V22.0185.42 C	566
U06.PL55.020.18 Y	554	U18.1020.02 M	546	V06.0080.000.40 G	600	V06.1630.02.22 EM	579	V22.0200.02 G	568
U06.ST40.020.18 Y	554	U18.1209.18 A ST	530	V06.0100.010.22 G	567	V06.1630.02.22 M	575	V22.0200.42 C	573
U06.UN08.02.18 M	549	U18.1209.18 B ST	532	V06.0100.010.28 G	590	V06.2140.02.22 EM	579	V22.0215.02 G	565
U06.UN10.02.18 M	549	U18.1209.32 A HM	529	V06.0100.010.37 G	599	V06.2140.02.22 M	575	V22.0215.42 C	566
U06.UN11.02.18 M	549	U18.1209.32 B HM	531	V06.0100.010.40 G	599	V06.2545.01.22 M	577	V22.0239.02 G	568
U06.UN12.02.18 M	549	U18.1209.45 A HM	529	V06.0117.010.22 G	567	V06.3050.01.28 M	593	V22.0250.02 G	568
U06.UN14.02.18 M	549	U18.1209.45 B HM	531	V06.0120.010.28 G	590	V06.4545.020.22 F	583	V22.0250.42 C	573
U06.UN16.02.18 M	549	U18.1209.64 A HM	529	V06.0120.020.28.09 G	589	V06.4545.020.28 F	583	V22.0265.02 G	565
U06.UN18.02.18 M	549	U18.1209.64 B HM	531	V06.0150.010.22 G	567	V06.5506.02.22 M	580	V22.0265.42 C	566
U06.UN20.02.18 M	549	U18.1309.25 A ST	530	V06.0150.010.28 G	590	V06.5508.02.22 M	580	V22.0300.02 G	568
U06.UN24.02.18 M	549	U18.1325.01 M	548	V06.0150.010.35 G	598	V06.5511.02.22 M	580	V22.0300.42 C	573
U15.4545.58 F	552	U18.1325.02 M	546	V06.0150.010.37 G	599	V06.PL50.020.20 Y	585	V22.0315.02 G	565
U18.0.500.09.32 A HM	529	U18.1609.18 A ST	530	V06.0150.010.37 GY	571	V06.PL50.020.28 Y	585	V22.0315.42 C	566
U18.0.500.09.32 B HM	531	U18.1609.18 B ST	532	V06.0150.010.40 G	599	V06.R020.22 F	584	V22.0318.02 G	568
U18.0.500.09.45 A HM	529	U18.1609.25 A HM	529	V06.0150.020.28.09 G	589	V06.R050.22 F	584	V22.0318.04 G	568
U18.0.500.09.45 B HM	531	U18.1609.25 B HM	531	V06.0157.010.22 G	567	V06.R060.22 F	584	V22.0350.02 G	568
U18.0.500.09.64 A HM	529	U18.1609.32 A HM	529	V06.0160.010.28 GY	570	V06.R080.22 F	584	V22.0356.02 G	568
U18.0.500.09.64 B HM	531	U18.1609.32 B HM	531	V06.0185.020.28 G	591	V06.R100.22 F	584	V22.0400.02 G	568
U18.0.625.09.18 A ST	530	U18.1609.45 A HM	529	V06.0200.020.22 G	567	V06.R125.22 F	584	V22.0400.04 G	568
U18.0.625.09.18 B ST	532	U18.1609.45 B HM	531	V06.0200.020.22 GY	569	V06.R150.22 F	584	V22.0400.42 C	573
U18.0.625.09.25 A HM	529	U18.1609.64 A HM	529	V06.0200.020.28 G	590	V06.R200.22 F	584	V22.0415.02 G	565
U18.0.625.09.25 B HM	531	U18.1609.64 B HM	531	V06.0200.020.28 GY	570	V06.R225.22 F	584	V22.0415.42 C	566
U18.0.625.09.32 A HM	529	U18.1612.45 B HM	531	V06.0200.020.28.09 G	589	V06.R250.22 F	584	V22.0437.02 G	568
U18.0.625.09.32 B HM	531	U18.1613.64 A HM	529	V06.0200.020.35 G	598	V06.R300.22 F	584	V22.0437.04 G	568
U18.0.625.09.45 A HM	529	U18.1613.64 B HM	531	V06.0200.020.35 GY	571	V06.ST40.020.22 Y	585	V22.0475.02 G	568
U18.0.625.09.45 B HM	531	U18.1613.66 A HM	529	V06.0200.020.37 GY	571	V22.0.500.13.42 A HM	557	V22.0500.02 G	568
U18.0.625.09.64 A HM	529	U18.1613.66 B HM	531	V06.0215.020.28 G	591	V22.0.500.13.42 B HM	560	V22.0515.02 G	565
U18.0.625.09.64 B HM	531	U18.1630.01 M	548	V06.0238.020.22 G	567	V22.0.500.13.60 A HM	557	V22.0515.04 G	565
U18.0.625.13.64 A HM	529	U18.1630.02 M	546	V06.0240.020.28.09 G	589	V22.0.500.13.60 B HM	560	V22.0515.42 C	566
U18.0.625.13.64 B HM	531	U18.1835.01 M	548	V06.0250.020.22 G	567	V22.0.625.11.30 A HM	557	V22.0635.02 G	568
U18.0.625.13.66 A HM	529	U18.1835.02 M	546	V06.0250.020.22 GY	569	V22.0.625.11.30 B HM	560	V22.0720.01 M	578
U18.0.625.13.66 B HM	531	U18.2535.01 M	548	V06.0250.020.25 GY	570	V22.0.625.12.24 A ST	558	V22.0815.01 M	578
U18.0010.20 V	544	U18.4545.20 F	552	V06.0250.020.28 G	590	V22.0.625.12.24 B ST	561	V22.0815.02 M	576
U18.0011.22 V	544	U18.4545.58 F	552	V06.0250.020.28 GY	570	V22.0.625.12.42 A HM	557	V22.0917.02 M	576
U18.0012.24 V	544	U18.B511.02 M	551	V06.0250.020.35 G	598	V22.0.625.12.42 B HM	560	V22.1011.10 A ST	558
U18.0015.30 V	544	U18.B514.02 M	551	V06.0250.020.35 GY	571	V22.0.625.12.60 A HM	557	V22.1020.01 M	578
U18.0070.00 Z	535	U18.B519.02 M	551	V06.0265.020.25 GY	570	V22.0.625.12.60 B HM	560	V22.1020.02 M	576
U18.0080.00 Z	535	U18.ER11.09.22	533	V06.0265.020.28 GY	570	V22.0.625.12.85 A HM	557	V22.1105.30 F	572
U18.0090.00 Z	535	U18.ER11.09.22.B	533	V06.0300.020.22 G	567	V22.0.625.12.85 B HM	560	V22.1212.42 A HM	556
U18.0110.00 G	535	U18.ER16.09.22	533	V06.0300.020.22 GY	569	V22.0005.10 V	574	V22.1212.42 B HM	559
U18.0110.40 C	536	U18.ER16.09.22.B	533	V06.0300.020.25 GY	570	V22.0008.16 V	574	V22.1212.60 A HM	556
U18.0117.00 G	539	U18.ER16.09.22.C	533	V06.0300.020.28 G	590	V22.0010.20 V	574	V22.1212.60 B HM	559
U18.0130.01 G	535	U18.ER20.09.22	533	V06.0300.020.28 GY	570	V22.0012.24 V	574	V22.1307.30 F	572
U18.0130.41 C	536	U18.ER20.09.22.B	533	V06.0300.020.35 G	598	V22.0014.28 V	574	V22.1308.30 F	572
U18.0142.00 G	539	U18.ER25.09.22	533	V06.0300.020.35 GY	571	V22.0015.30 V	574	V22.1311.25 A ST	558
U18.0150.02 G	539	U18.ER25.09.22.B	533	V06.0318.020.22 G	567	V22.0020.40 V	574	V22.1609.35 F	572
U18.0150.42 C	543	U18.UN06.02 M	550	V06.0350.020.28 GY	570	V22.0022.44 V	574	V22.1610.35 F	572
U18.0157.02 G	539	U18.UN07.02 M	550	V06.0400.020.22 G	567	V22.0024.48 V	574	V22.1611.30 A HM	556
U18.0160.01 G	535	U18.UN08.02 M	550	V06.0400.020.22 GY	569	V22.0025.50 V	574	V22.1611.30 B HM	559
U18.0160.41 C	536	U18.UN10.02 M	550	V06.0400.020.25 GY	570	V22.0032.64 V	574	V22.1612.00.06 A ST	562
U18.0200.02 G	539	U18.UN11.02 M	550	V06.0400.020.28 G	590	V22.0062.12 V	574	V22.1612.00.10 A ST	562
U18.0200.42 C	543	U18.UN12.02 M	550	V06.0400.020.28 GY	570	V22.0070.00 Z	565	V22.1612.24 A ST	558
U18.0239.02 G	539	U18.UN14.02 M	550	V06.0500.020.25 GY	570	V22.0080.00 Z	565	V22.1612.24 B ST	561
U18.0250.02 G	539	U18.UN16.02 M	550	V06.0500.020.28 G	590	V22.0090.00 Z	565	V22.1612.42 A HM	556
U18.0250.42 C	543	U18.UN18.02 M	550	V06.0500.020.28 GY	570	V22.0100.00 Z	565	V22.1612.42 B HM	559
U18.0300.02 G	539	U18.UN20.02 M	550	V06.0600.020.25 GY	570	V22.0100.01 G	568	V22.1612.60 A HM	556
U18.0300.42 C	543	U18.UN24.02 M	550	V06.0600.020.28 G	590	V22.0110.00 Z	565	V22.1612.60 B HM	559
U18.0318.02 G	539	U20.0150.02 G	540	V06.0600.020.28 GY	570	V22.0130.01 G	565	V22.1612.85 A HM	556
U18.0400.02 G	539	U20.0200.02 G	540	V06.0720.01.22 M	577	V22.0130.41 C	566	V22.1612.85 B HM	559
U18.0510.01 M	548	U20.0250.02 G	540	V06.0815.02.22 EM	579	V22.0150.02 G	568	V22.1630.01 M	578
U18.0720.01 M	548	V06.0040.000.40 G	600	V06.0815.02.22 M	575	V22.0150.42 C	573	V22.1630.02 M	576
U18.0815.01 M	548	V06.0050.000.37 G	600	V06.0917.02.22 EM	579	V22.0157.02 G	568	V22.1812.35 F	572
U18.0815.02 M	546	V06.0050.000.40 G	600	V06.0917.02.22 M	575	V22.0160.01 G	565	V22.1835.02 M	576
U18.0917.02 M	546	V06.0060.000.37 G	600	V06.1020.02.22 EM	579	V22.0160.41 C	566	V22.2016.45 A HM	556

simmill AX

simmill PMX

simmill PX

simmill SX

simmill UX

simmill VX

simmill H2

simmill K2

simmill MX

simmill OS

Index

Index

simmill Produktverzeichnis
simmill Product List

Artikelnr. // Part Nr.	S/P	Artikelnr. // Part Nr.	S/P
V22.2016.65 A HM	556	V28.0635.02 G	587
V22.2016.65 B HM	559	V28.0720.01 M	594
V22.2140.01 M	578	V28.1000.02 G	587
V22.2140.02 M	576	V28.1314.10 A ST	558
V22.2215.35 F	572	V28.1525.01 M	594
V22.2445.01 M	578	V28.1614.42 A HM	556
V22.2445.02 M	576	V28.1614.42 B HM	559
V22.2545.01 M	578	V28.1614.60 A HM	556
V22.2616.45 F	572	V28.1614.60 B HM	559
V22.2617.45 F	572	V28.1614.85 A HM	556
V22.3118.45 F	572	V28.1614.85 B HM	559
V22.4120.55 F	572	V28.2013.35 A HM	556
V22.4125.55 F	572	V28.2013.35 B HM	559
V22.4545.58 F	582	V28.2014.35 A ST	558
V22.4545.94 F	582	V28.2014.35 B ST	561
V22.5506.02 M	581	V28.2014.85 A HM	556
V22.5508.02 M	581	V28.2014.85 B HM	559
V22.5511.02 M	581	V28.3050.01 M	594
V22.C312.18	564	V28.5060.01 M	594
V22.ER16.12.30	563	V28.ER20.14.35	563
V22.ER16.12.30.B	563	V28.ER20.14.35.B	563
V22.ER16.12.30.C	563	V28.ER25.14.35	563
V22.ER20.12.30	563	V28.ER25.14.35.B	563
V22.ER20.12.30.B	563	V28.ER32.14.35	563
V22.ER25.12.30	563	V32.0150.02.11 G	595
V22.ER25.12.30.B	563	V32.0160.02.11 G	595
V22.ER25.14.19	563	V32.0200.02 G	595
V22.ER25.14.19.B	563	V32.0200.02.11 G	595
V22.ER32.12.30	563	V32.0200.42 C	596
V22.ER32.14.19	563	V32.0250.02 G	595
V25.0016.318 V	574	V32.0250.42 C	596
V25.0200.02 G	586	V32.0300.02 G	595
V25.0239.02 G	586	V32.0300.02.11 G	595
V25.0250.02 G	586	V32.0300.42 C	596
V25.0300.02 G	586	V32.0600.42 C	596
V25.0318.02 G	586	V33.0.625.09.20 B ST	561
V25.0350.02 G	586	V33.0.625.09.33 B HM	560
V25.0400.02 G	586	V33.0110.42.10 C	597
V25.0475.02 G	586	V33.0120.42.10 C	597
V25.0500.02 G	586	V33.0132.42.10 C	597
V28.0.625.14.42 A HM	557	V33.0150.42.10 C	597
V28.0.625.14.42 B HM	560	V33.0160.42.10 C	597
V28.0.625.14.60 A HM	557	V33.0170.42.10 C	597
V28.0.625.14.60 B HM	560	V33.0170.42.12 C	597
V28.0.625.14.85 A HM	557	V33.0200.42.10 C	597
V28.0.625.14.85 B HM	560	V33.0200.42.12 C	597
V28.0.750.14.35 A ST	558	V33.0250.42.10 C	597
V28.0016.318 V	574	V33.0250.42.12 C	597
V28.0032.635 V	574	V33.1609.20 B ST	561
V28.0150.02 G	587	V33.1609.33 A HM	556
V28.0150.02.09 G	588	V33.1609.33 B HM	559
V28.0160.02.09 G	588		
V28.0200.02 G	587		
V28.0200.02.09 G	588		
V28.0200.42 C	592		
V28.0250.02 G	587		
V28.0250.02.09 G	588		
V28.0250.42 C	592		
V28.0300.02 G	587		
V28.0300.42 C	592		
V28.0350.02 G	587		
V28.0350.42 C	592		
V28.0400.02 G	587		
V28.0400.42 C	592		
V28.0500.02 G	587		
V28.0600.02 G	587		

simcut
SIMTEK CUTTING TOOLS

Info

Die simcut Produktgruppen The simcut Product Groups

simcutBA
SIMTEK broaching type BA

simcutBF
SIMTEK broaching type BF



Nutstoßen
Broaching

Seite // Page

659

simcutFX
SIMTEK thread whirling type FX



Gewindewirbeln
Thread whirling applications

Seite // Page

697



simcutK2
SIMTEK thread whirling type K2



Gewindewirbeln
Thread whirling applications

Seite // Page

710



simcutMX
SIMTEK polygon milling type MX



Mehrkantfräsen
Polygon milling tools

Seite // Page

720



Ein Verzeichnis aller Werkzeuge finden Sie auf Seite 735
A list of all the tools can be found on page 735

Im PDF-Katalog sind alle Webcodes und Querverweise verlinkt.
Per Klick gelangen Sie darüber zu den verknüpften Informationen.

The Webcodes and cross-references are interactive links in the PDF-catalog.
A click on these links leads to the connected information.

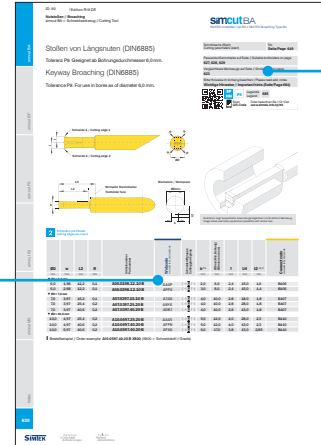
Zur Nutzung des Katalogs // Using the catalog

Der Webcode und weitere Querverweise The Webcode and more cross-references

Der **Webcode**, in jeder Katalogseitenzeile
The **Webcode**, shown on every catalog page line

Der Webcode stellt eine eindeutige und schnelle Verbindung in die digitale Welt dar. Verwenden Sie den Webcode u.a. im Internet um tagesaktuelle Informationen zu erhalten.

The webcode is a unique and fast connection between our part numbers and the digital world. Use it on our website and get up-to-date information fast, easy and reliable.



<http://www.simtek.com/webcode/>

Der Webcode besteht im Standardbereich aus einem alphanumerischen vierstelligen Code. Dieser Code beschreibt jeden Artikel eindeutig:

The Webcode is a four digit alphanumeric code which is available for every standard item.
This code is unique for every item:



Beispiel // Example

Gerne können Sie diesen Webcode auch zur Bestellung verwenden. Hängen Sie dazu im Bestellfall - wie bei Schneidwerkzeugen gewohnt - noch den gewünschten Schneidstoff an.

You can also use this Webcode for your ordering process. Just add the grade code - if ordering a cutting insert - and the short ordering code is complete.

Zusätzliche **Querverweise** und **Informationen**, auf jeder Katalogseite
Extra **cross-references** and **information**, shown on every catalog page

Schnittwerte (Start) Cutting parameters (start) Vc Seite/Page 649

Passende Klemmhalter auf Seite // Suitable toolholders on page 627, 628, 629

Vergleichbare Werkzeuge auf Seite // Similar tools on page 623

Bitte Hinweise im Anhang beachten // Please read add. notes
Wichtige Hinweise // Important hints (Seite/Page 684)

Legende Legend 685
 Oder besuchen Sie // Or Visit www.simtek.info/cp/90

Im rechten oberen Bereich erhalten Sie zusätzliche Querverweise angezeigt. Diese führen zu passenden Trägerwerkzeugen, vergleichbaren Werkzeugen, Schnittwerten und weiterführenden Hinweisen. Die entsprechenden Informationen finden Sie auf den angegebenen Seitenzahlen.

You can find additional information and cross-references in the upper right corner. These cross-references lead to compatible toolholders, similar tools, cutting parameters and additional notes. The corresponding information can be found on the shown page numbers.

Der Connectcode The Connectcode

Nutzen Sie den „Connectcode“ um auf einfachste Weise zu ermitteln, welche Kombination aus Schneidwerkzeug und Werkzeugträger von uns empfohlen ist. Dieser „Connectcode“ wird sowohl bei Schneidwerkzeugen als auch bei Werkzeugträgern ausgewiesen - vorausgesetzt das System benötigt ein Trägerwerkzeug für den Einsatz.

Stimmen beide Werte überein, können Sie diese Kombination bedenkenlos einsetzen.

Andere Kombinationen sind ebenfalls möglich, jedoch können diese zu einem eingeschränkten Funktionsumfang führen.

Please use the „Connectcode“ in order to verify which combination between cutting insert and toolholder is recommended. This „Connectcode“ is shown on catalog pages of cutting inserts as well as on catalog pages of toolholders - if the tool system does not require the use of a toolholder, no „Connectcode“ is given.

Identical values indicate that the combination of insert and toolholder is recommended.

Different combinations can be possible too at the possible expense of other tool characteristics.

Connectcode www.simtek.com/code	Schneidwerkzeug // Cutting tool							
	BA06	BA07	BA10	BF10	BF12.08	BF12.10	BF12.12	
Trägerwerkzeug // Toolholder								
BA06	●	-	-	-	-	-	-	
BA07	-	●	-	-	-	-	-	
BA10	-	-	●	-	-	-	-	
BF10	-	-	-	●	-	-	-	
BF12*	-	-	-	-	●	●	●	
BF12.08	-	-	-	-	●	○	○	
BF12.10	-	-	-	-	-	●	○	
BF12.12	-	-	-	-	-	-	●	

- **Empfohlene Kombination // Recommended combination**
- Baulich mögliche Kombination, mit abweichendem Funktionsumfang // Constructionally possible combination but with differing functionality

Die obige Tabelle zeigt die in diesem Katalog verwendeten „Connectcodes“ an. Ein ausgefüllter blauer Punkt in der Schnittstelle steht für eine vollständige Kompatibilität.

This table contains all the „Connectcodes“ from this catalog. A full blue circle on the intersection of cutting tool and toolholder indicates that the connection of both items is recommended.

Info

Die simcut Nutstoßwerkzeuge
The simcut Broaching Tools

simcutBA | BF
SIMTEK broaching type BA

simcut BF

Nutstoßwerkzeuge für Innenprofile in Bohrungen ab Durchmesser 14,0 mm
Broaching tools for internal profiles in bores as of diameter 14,0 mm



simcut BA

Nutstoßwerkzeuge für Innenprofile in Bohrungen ab Durchmesser 6,0 mm
Broaching tools for internal profiles in bores as of diameter 6,0 mm

Standard- und Sonderwerkzeuge für Nutstoßanwendungen Standard and Special Tools for Broaching Applications

Schneidwerkzeuge // Cutting tools



Das simcut Werkzeugsystem für das Nutstoßen, bietet **Standardschneidwerkzeuge** für die folgenden Profile:

- Längsnuten nach DIN 6885
- Längsnuten nach DIN 138
- Innensechskant
- Längsnuten nach Inch-Norm



Die Schneidwerkzeugauswahl wird ergänzt durch individuelle Werkzeuge für die Fertigung von speziellen Profilen, bspw. für **Evolventenverzahnungen**.



In diesem Katalog enthalten, sind die Standard-Schneidwerkzeuge für das Stoßen von Längsnuten.

Bitte sprechen Sie uns an, wenn Sie eines der anderen Profile benötigen.

The simcut tool system for broaching applications offers **standard cutting tools** for the following profiles:

- Keyways (according to DIN 6885)
- Keyways (according to DIN 138)
- Hexagon socket
- Keyways (according to Inch-Standards)

The insert range is extended by individual tools for special profiles, such as **involute toothing profiles** and others.

This catalog contains our standard cutting inserts for keyway broaching.

Please contact us in case you need one of the other profiles.

Trägerwerkzeuge // Toolholder

Für alle Standard- und Individual-Schneidwerkzeuge stehen zwei Arten von Trägerwerkzeugen zur Verfügung:

- Klemmhalter für konventionelles Nutstoßen

sowie

- Klemmhalter für angetriebene Nutstoßaggregate:

Schwarzer "Version 1" *
Schwarzer "2in1" *
Benz "LinA"
EWS "Slot"

Two kinds of toolholders are available for holding the range of Standard and special customized cutting inserts:

- Toolholders for conventional broaching

as well as

- Toolholders for broaching units:

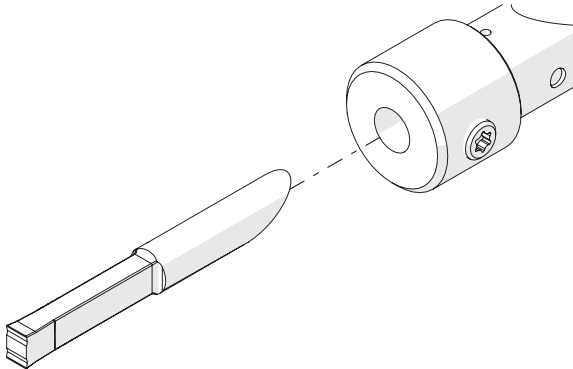
Schwarzer "Version 1" *
Schwarzer "2in1" *
Benz "LinA"
EWS "Slot"

Info

Das Werkzeugsystem simcut BA The Tool System simcut BA

simcutBA
SIMTEK broaching type BA

- + System bestehend aus Stahlträgerwerkzeug und wechselbarem Hartmetall-Schneideinsatz
System of steel toolholder and carbide milling insert



- + Geeignet für Innenprofile in Bohrungen ab Bohrungsdurchmesser 6,0 mm
For internal use in bores as of bore diameter 6,0 mm
- + Standardträgerwerkzeuge für konventionelles Nutstoßen, sowie für Nutstoßaggregate
Standard toolholders for conventional broaching, as well as for broaching units
- + Standardschneidwerkzeuge in umfangreicher Auswahl
Wide range of standard cutting inserts
- + Individuelle, spezielle Profile auf Anfrage
Individual, special profiles upon request
- + 2 Schneiden pro Einsatz
2 cutting edges per insert



Ab Seite // As of page

663 Anwendungsübersicht
Application overview

666 Alle Werkzeuge
All tools

simcut BA

simcut BF

simcut FX

simcut K2

simcut MX

Index

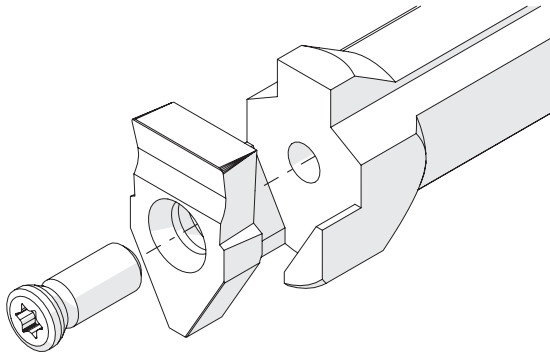
661

Info

Das Werkzeugsystem simcut BF The Tool System simcut BF

simcutBF
SIMTEK broaching type BF

- + System bestehend aus Stahlträgerwerkzeug und wechselbarem Hartmetall-Schneidplatte
System of steel toolholder and carbide milling insert



- + Geeignet für Innenprofile in Bohrungen ab Bohrungsdurchmesser 14,0 mm
For internal use in bores as of bore diameter 14,0 mm
- + Standardträgerwerkzeuge für konventionelles Nutstoßen, sowie für Nutstoßaggregate
Standard toolholders for conventional broaching, as well as for broaching units
- + Standardschneidwerkzeuge in umfangreicher Auswahl
Wide range of standard cutting inserts
- + Individuelle, spezielle Profile auf Anfrage
Individual, special profiles upon request



Ab Seite // As of page

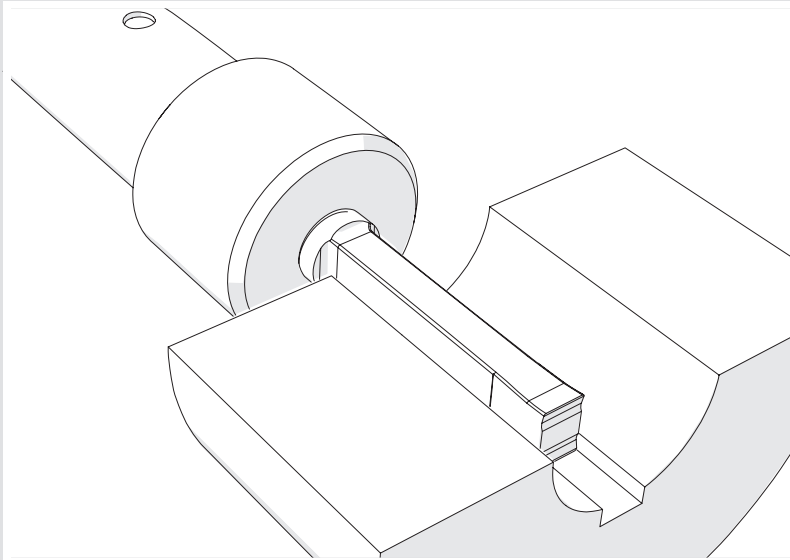
663

Anwendungsübersicht
Application overview

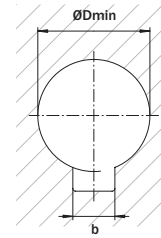
678

Alle Werkzeuge
All tools

Stoßen von Längsnuten (DIN 6885 / DIN 138) Keyway Broaching (DIN 6885 / DIN 138)



Werkstück / Workpiece



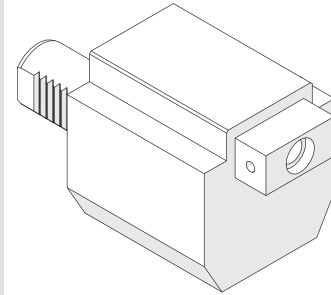
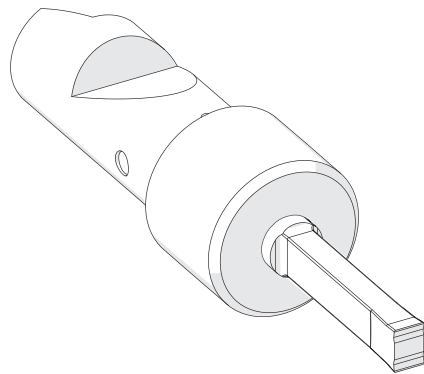
Standardwerkzeuge sind verfügbar für die folgenden Toleranzklassen. Weitere Toleranzen auf Anfrage!
Standard tools are available for the following tolerance classes. Further tolerance classes upon request.

P9 JS9 H9 C11

Artikelnummer Part number	$\varnothing D_{min}$ (Min. Bohrung) $\varnothing D_{min}$ (min. bore)	b	siehe Seite see Page
A06.0198.12.10 B	6,0	2,0 ^{P9}	672
A06.0200.12.10 B	6,0	2,0 ^{JS9}	673
A06.0202.12.10 B	6,0	2,0 ^{H9}	674
A06.0298.12.10 B	8,0	3,0 ^{P9}	672
A06.0300.12.10 B	8,0	3,0 ^{JS9}	673
A06.0302.12.10 B	8,0	3,0 ^{H9}	674
A07.0397.15.10 B	10,0	4,0 ^{P9}	672
A07.0397.25.20 B	10,0	4,0 ^{P9}	672
A07.0397.40.20 B	10,0	4,0 ^{P9}	672
A07.0400.15.10 B	10,0	4,0 ^{JS9}	673
A07.0400.15.20 B	10,0	4,0 ^{JS9}	673
A07.0400.25.20 B	10,0	4,0 ^{JS9}	673
A07.0400.40.20 B	10,0	4,0 ^{JS9}	673
A07.0402.15.10 B	10,0	4,0 ^{H9}	674
A07.0402.25.20 B	10,0	4,0 ^{H9}	674
A07.0402.40.20 B	10,0	4,0 ^{H9}	674
A10.0497.25.20 B	12,0	5,0 ^{P9}	672
A10.0497.40.20 B	12,0	5,0 ^{P9}	672
A10.0500.25.20 B	12,0	5,0 ^{JS9}	673
A10.0500.40.20 B	12,0	5,0 ^{JS9}	673
A10.0502.25.20 B	12,0	5,0 ^{H9}	674
A10.0502.40.20 B	12,0	5,0 ^{H9}	674
F10.0500.02.14 B	14,0	5,0 ^{JS9}	688
F10.0498.02 B	17,0	5,0 ^{P9}	686
F10.0500.02 B	17,0	5,0 ^{JS9}	688
F10.0502.02 B	17,0	5,0 ^{H9}	690
A10.0597.40.20 B	17,0	6,0 ^{P9}	672
A10.0600.40.20 B	17,0	6,0 ^{JS9}	673
A10.0602.40.20 B	17,0	6,0 ^{H9}	674
F10.0598.02 B	17,0	6,0 ^{P9}	686
F10.0600.02 B	17,0	6,0 ^{JS9}	688
F10.0602.02 B	17,0	6,0 ^{H9}	690
F10.0796.02 B	22,0	8,0 ^{P9}	686
F10.0800.02 B	22,0	8,0 ^{JS9}	688
F10.0802.02 B	22,0	8,0 ^{H9}	690
F12.0796.02 B	22,0	8,0 ^{P9}	687
F12.0800.02 B	22,0	8,0 ^{JS9}	689
F12.0800.02.05 B	22,0	8,0 ^{JS9}	689
F12.0802.02 B	22,0	8,0 ^{H9}	691
F12.0996.03 B	30,0	10,0 ^{P9}	687
F12.1000.03 B	30,0	10,0 ^{JS9}	689

Artikelnummer Part number	$\varnothing D_{min}$ (Min. Bohrung) $\varnothing D_{min}$ (min. bore)	b	siehe Seite see Page
F12.1000.03.05 B	30,0	10,0 ^{JS9}	689
F12.1002.03 B	30,0	10,0 ^{H9}	691
F12.1196.03 B	38,0	12,0 ^{P9}	687
F12.1200.03 B	38,0	12,0 ^{JS9}	689
F12.1200.03.05 B	38,0	12,0 ^{JS9}	689
F12.1200.05 B	38,0	12,0 ^{JS9}	689
F12.1202.03 B	38,0	12,0 ^{H9}	691
F12.1600.03 B	38,0	16,0 ^{JS9}	689
F12.1396.03 B	40,0	14,0 ^{P9}	687
F12.1400.03 B	40,0	14,0 ^{JS9}	689

Standardwerkzeuge // Standard Tools

Trägerwerkzeuge für Nutstoßaggregate
Toolholder for Push-Slotting Aggregat

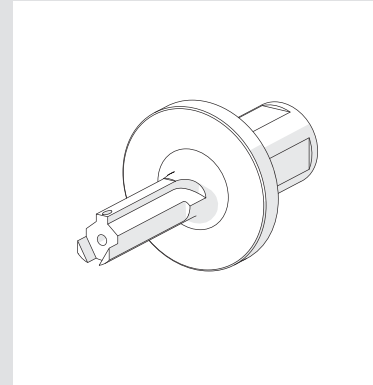
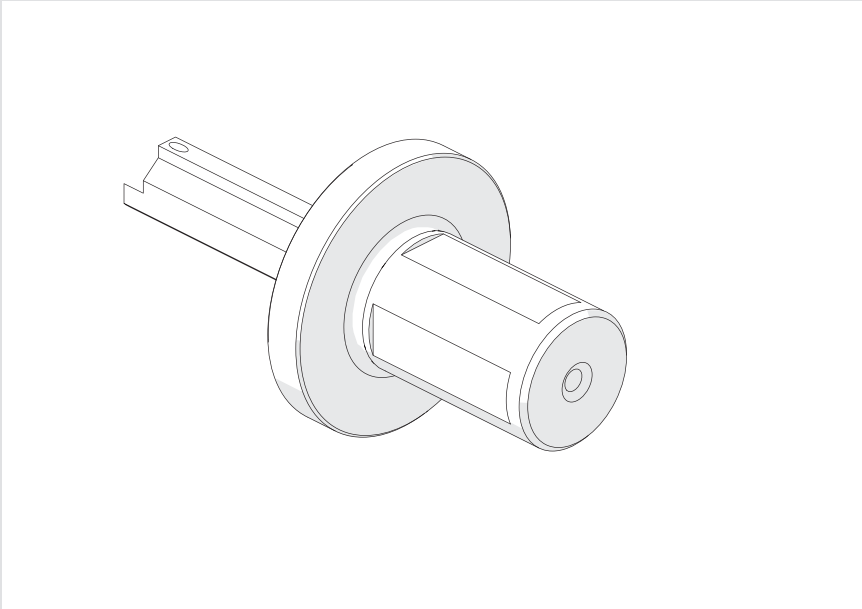
Standardträgerwerkzeuge für Nutstoßaggregate sind verfügbar für die folgenden Bauarten.

Standard toolholders for broaching units are available for the following units.

Schwarzer "Version 1" Benz "LinA"
Schwarzer "2in1" EWS "Slot"

Artikelnummer Part number	Für Nutstoßaggregate For broaching unit	siehe Seite see Page
F10.SB20.35-B IC	BENZ LinA 4.0/ EWS P20	683
F10.SB20.53-B IC	BENZ LinA 4.0/ EWS P20	683
A06.SB16-B	BENZ LinA/EWS Slot	671
A07.SB16-B	BENZ LinA/EWS Slot	671
A10.SB16-B	BENZ LinA/EWS Slot	671
F10.SB16.35-B	BENZ LinA/EWS Slot	683
F10.SB16.53-B	BENZ LinA/EWS Slot	683
A06.SB15.00-S	Schwarzer 2in1	668
A06.SB15.00-SK	Schwarzer 2in1	668
A07.SB15.00-S	Schwarzer 2in1	668
A07.SB15.00-SK	Schwarzer 2in1	668
F10.SB15.18-S	Schwarzer 2in1	682
F10.SB15.26-S	Schwarzer 2in1	682
F10.SB15.36-S	Schwarzer 2in1	682
F10.SB15.42-S	Schwarzer 2in1	682

Trägerwerkzeuge für konventionelles Nutstoßen Toolholder for conventional Broaching



Artikelnummer Part number	ØDg6	siehe Seite see Page
A07.SB.0.625	15,875	667
A06.SB16	16,0	667
A07.SB16	16,0	667
A06.SB.0.750	19,05	667
A07.SB.0.750	19,05	667
A06.SB20	20,0	667
A07.SB20	20,0	667
A06.SB25	25,0	667
A07.SB25	25,0	667
A10.SB25	25,0	667
F10.03.40.25.14	25,0	680
F10.05.40.25	25,0	680
F10.05.40.25.14	25,0	680
F10.SB25.56.ZB	25,0	679
F10.SB25.56.14.ZB	25,0	679
F10.SB25.80.ZB	25,0	679
F39.06.50.25	25,0	681
F39.06.70.25	25,0	681
F39.08.50.25	25,0	681
F39.08.75.25	25,0	681
A06.SB.1.000	25,4	667
A10.SB.1.000	25,4	667
F10.05.40.1.000	25,4	680
F39.08.51.1.000	25,4	681
F39.08.76.1.000	25,4	681
F39.10.51.1.250	31,75	681
F39.10.76.1.250	31,75	681
F39.12.76.1.250	31,75	681
A07.SB32	32,0	667
A10.SB32	32,0	667
F10.05.40.32	32,0	680
F10.SB32.56.ZB	32,0	679
F10.SB32.80.ZB	32,0	679
F39.10.10.32	32,0	681
F39.10.50.32	32,0	681
F39.10.75.32	32,0	681
F39.12.10.32	32,0	681
F39.12.50.32	32,0	681
F39.12.75.32	32,0	681
F39.16.12.32	32,0	681

simcutBA
SIMTEK broaching type BA



Ab Seite // As of page

663

Anwendungsübersicht
Application overview

Klemmhalter für konventionelles Nutstoßen

Geeignet für das konventionelle Nutstoßen von Standard- und Sonderprofilen auf geeigneten CNC-Maschinen.

Toolholder for conventional broaching

For conventional broaching of standard and special profiles on capable CNC-machines.

Anzugsmoment (Schraube) // Tightening torque (screw)

"A M6x7,5 T15F": 7,0 Nm
"A M6x7,5T15F": 7,0 Nm

Vergleichbare Werkzeuge auf Seite // Similar tools on page
665

Bitte Hinweise im Anhang beachten // Please read add. notes

Wichtige Hinweise // Important hints (Seite/Page 733)

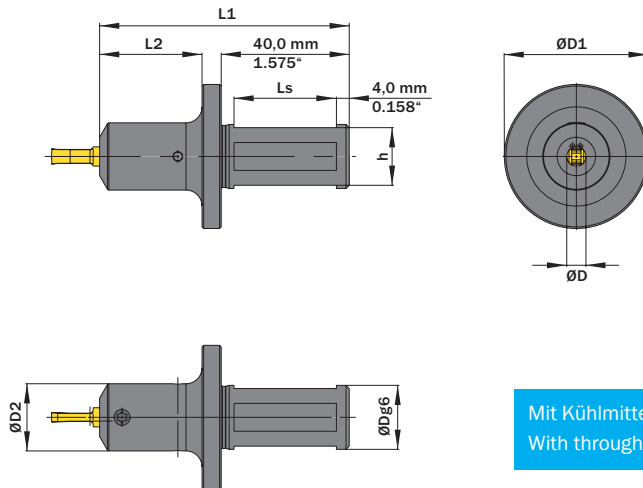


Legende
Legend **734**



Scan
QR-Code

Oder besuchen Sie // Or Visit
www.simtek.info/cp/88



Mit Kühlmittelzufuhr
With through coolant supply

Abbildung zeigt / Drawing shows: A06.SB20

ØD	ØDg6	Artikelnummer Part number	Webcode www.simtek.com/webcode	Mit Kühlmittelzufuhr With through coolant supply	ØD1	ØD2	h	L1	L2	Ls	Schraube Screw	Schraubenschlüssel Screw driver	Connectcode www.simtek.com/code		
														mm	mm
▼ ØD = 6,0 mm															
6,0	19,05	A06.SB.0.750	A555	Ja / Yes	45,0	21,0	17,0	78,0	32,0	32,0	A M6x7,5 T15F	T15F	BA06	new	inch
6,0	25,4	A06.SB.1.000	A3DK	Ja / Yes	50,0	21,0	23,4	78,0	32,0	32,0	A M6x7,5 T15F	T15F	BA06	new	inch
6,0	16,0	A06.SB16	AWY9	Ja / Yes	38,0	21,0	14,0	78,0	32,0	32,0	A M6x7,5 T15F	T15F	BA06		
6,0	20,0	A06.SB20	AA00	Ja / Yes	45,0	21,0	18,0	78,0	32,0	32,0	A M6x7,5 T15F	T15F	BA06		
6,0	25,0	A06.SB25	AGC0	Ja / Yes	50,0	21,0	23,0	78,0	32,0	32,0	A M6x7,5 T15F	T15F	BA06		
▼ ØD = 7,0 mm															
7,0	15,875	A07.SB.0.625	A6D9	Nein / No	38,0	22,0	13,9	78,0	32,0	32,0	A M6x7,5 T15F	T15F	BA07	new	inch
7,0	19,05	A07.SB.0.750	A4VT	Ja / Yes	45,0	22,0	17,0	78,0	32,0	32,0	A M6x7,5 T15F	T15F	BA07	new	inch
7,0	16,0	A07.SB16	AWZA	Nein / No	38,0	22,0	14,0	78,0	32,0	32,0	A M6x7,5 T15F	T15F	BA07		
7,0	20,0	A07.SB20	AAEE	Ja / Yes	45,0	22,0	18,0	78,0	32,0	32,0	A M6x7,5 T15F	T15F	BA07		
7,0	25,0	A07.SB25	AKVH	Ja / Yes	50,0	22,0	23,0	78,0	32,0	32,0	A M6x7,5 T15F	T15F	BA07		
7,0	32,0	A07.SB32	AKJF	Ja / Yes	58,0	22,0	30,0	78,0	32,0	32,0	A M6x7,5 T15F	T15F	BA07		
▼ ØD = 10,0 mm															
10,0	25,4	A10.SB.1.000	A5QV	Ja / Yes	50,0	25,0	23,4	86,0	40,0	32,0	A M6x7,5 T15F	T15F	BA10	new	inch
10,0	25,0	A10.SB25	AJ7X	Ja / Yes	50,0	25,0	23,0	86,0	40,0	32,0	A M6x7,5 T15F	T15F	BA10		
10,0	32,0	A10.SB32	AD2N	Ja / Yes	58,0	25,0	30,0	86,0	40,0	32,0	A M6x7,5 T15F	T15F	BA10		

Bestellbeispiel // Order example: **A10.SB25**

Klemmhalter für Nutstoßaggregate

Geeignet für das Nutstoßen von Standard- und Sonderprofilen auf Nutstoßaggregat „Schwarzer 2in1“.

Toolholder for broaching units

For broaching of standard and special profiles on broaching unit „Schwarzer 2in1“.

Anzugsmoment (Schraube) // Tightening torque (screw)

7,0 Nm

Vergleichbare Werkzeuge auf Seite // Similar tools on page
664

Bitte Hinweise im Anhang beachten // Please read add. notes

Wichtige Hinweise // Important hints (Seite/Page 733)

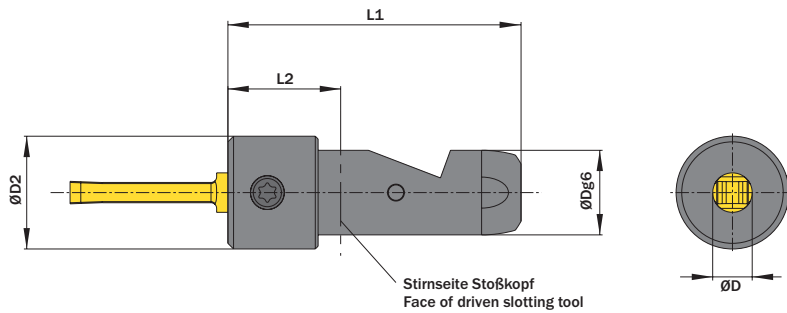


Legende
Legend **734**



Scan
QR-Code

Oder besuchen Sie // Or Visit
www.simtek.info/cp/261



Schwarzer Version 1 Aufnahme auf Anfrage erhältlich.
Schwarzer Version 1 fixation available upon request.

Abbildung zeigt / Drawing shows: A06.SB15.00-S

Für Nutstoßaggregat For broaching unit	ØD	ØDg6	Artikelnummer Part number	Webcode www.simtek.com/webcode	ØD2	L1	L2	Schraube Screw	Schraubenschlüssel Screw driver	Connectcode www.simtek.com/code
	mm	mm			mm	mm	mm	mm	mm	
▼ ØD = 6,0 mm										
Schwarzer 2in1	6,0	15,0	A06.SB15.00-S	AP45	20,0	52,0	20,0	A M6x7,5 T15F	T15F	BA06
Schwarzer 2in1	6,0	15,0	A06.SB15.00-SK	APWU	20,0	47,0	15,0	A M6x7,5 T15F	T15F	BA06
▼ ØD = 7,0 mm										
Schwarzer 2in1	7,0	15,0	A07.SB15.00-S	AP49	20,0	52,0	20,0	A M6x7,5 T15F	T15F	BA07
Schwarzer 2in1	7,0	15,0	A07.SB15.00-SK	AD7A	20,0	47,0	15,0	A M6x7,5 T15F	T15F	BA07

Bestellbeispiel // Order example: **A07.SB15.00-S**

Klemmhalter für Nutstoßaggregate

Geeignet für das Nutstoßen von Standard- und Sonderprofilen auf Nutstoßaggregat „WTO“.

Toolholder for Broaching Units

For broaching of standard and special profiles on broaching units „WTO“.

Bitte Hinweise im Anhang beachten // Please read add. notes

Wichtige Hinweise // Important hints (Seite/Page 733)



TW
ST

ME

Legende
Legend

734



Scan
QR-Code

Oder besuchen Sie // Or Visit
www.simtek.info/cp/1267

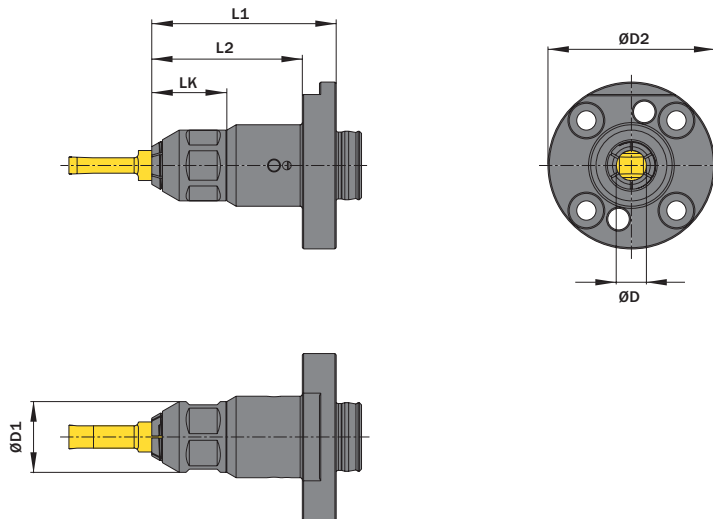


Abbildung zeigt / Drawing shows: A07.SB16.ME-W

Für Nutstoßaggregat For broaching unit	ØD	Artikelnummer Part number	Webcode www.simtek.com/webcode	ØD1	ØD2	L1	L2	LK	Standard Mutter Standard screw nut	Connectcode www.simtek.com/code
	mm			mm	mm	mm	mm	mm		
wto	6,0	A06.SB16.ME-W	A03X	16,5	38,9	43,0	35,1	17,5	A00.K.16.12.108	BA06
wto	7,0	A07.SB16.ME-W	A1Q9	16,5	38,9	43,0	35,1	17,5	A00.K.16.12.108	BA07

Bestellbeispiel // Order example: **A07.SB16.ME-W**

Klemmhalter für Nutstoßaggregate

Geeignet für das Nutstoßen von Standard- und Sonderprofilen auf Nutstoßaggregat „Benz LinA 4.0“ und „EWS P20“. Mit ME-Spannprinzip.

Toolholder for broaching units

For broaching of standard and special profiles on broaching unit „Benz LinA 4.0“ and „EWS P20“. With ME clamping system.

Bitte Hinweise im Anhang beachten // Please read add. notes

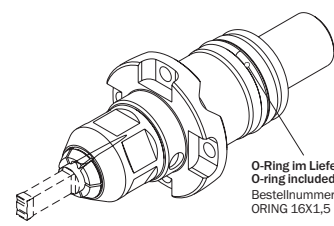
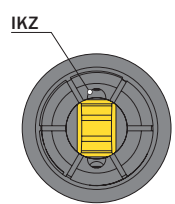
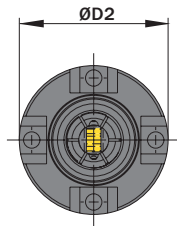
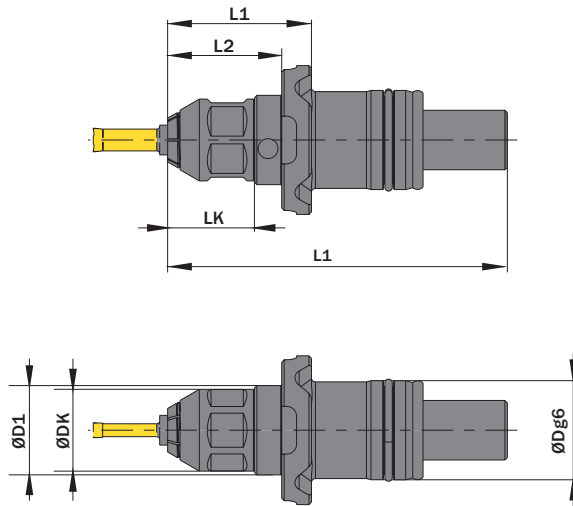
Wichtige Hinweise // Important hints (Seite/Page 733)



Legende Legend **734**



Oder besuchen Sie // Or Visit www.simtek.info/cp/1381



O-Ring im Lieferumfang enthalten
O-ring included in scope of delivery
Bestellnummer // part number:
ORING 16X1.5 FPM80 GR

Abbildung zeigt / Drawing shows: A06.SB20.ME-B IC

Für Nutstoßaggregat For broaching unit	ØDg6	L2	L1	Artikelnummer Part number	Webcode www.simtek.com/webcode	ØDK	ØD1	ØD2	L3 (Max. Bohrungstiefe) L3 (max. depth of bore)	LK	Mutter Screw nut	Prismen-Fixiersystem Variante Prism fixation system variant	Connectcode www.simtek.com/code	new
	mm	mm	mm			mm	mm	mm						
BENZ LinA 4.0/EWS P20	20,0	23,0	29,0	A06.SB20.ME-B IC	A61Z	16,5	18,0	30,0	68,5	17,5	A00.K.16.12.108	1+3	BA06	new
BENZ LinA 4.0/EWS P20	20,0	23,0	29,0	A07.SB20.ME-B IC	A611	16,5	18,0	30,0	68,5	17,5	A00.K.16.12.108	1+3	BA07	new
BENZ LinA 4.0/EWS P20	20,0	28,0	34,0	A10.SB20.ME-B IC	A613	19,0	19,0	30,0	73,5	17,5	A00.K.16.12.108	1+3	BA10	new

Bestellbeispiel // Order example: **A07.SB20.ME-B IC**

Klemmhalter für Nutstoßaggregate

Geeignet für das Nutstoßen von Standard- und Sonderprofilen auf Nutstoßaggregat „Benz LinA“ und „EWS Slot“.

Toolholder for broaching units

For broaching of standard and special profiles on broaching unit „Benz LinA“ and „EWS Slot“.

Anzugsmoment (Schraube) // Tightening torque (screw)

7,0 Nm

Vergleichbare Werkzeuge auf Seite // Similar tools on page
664

Bitte Hinweise im Anhang beachten // Please read add. notes

Wichtige Hinweise // Important hints (Seite/Page 733)



Legende
Legend

734



Scan
QR-Code

Oder besuchen Sie // Or Visit
www.simtek.info/cp/461

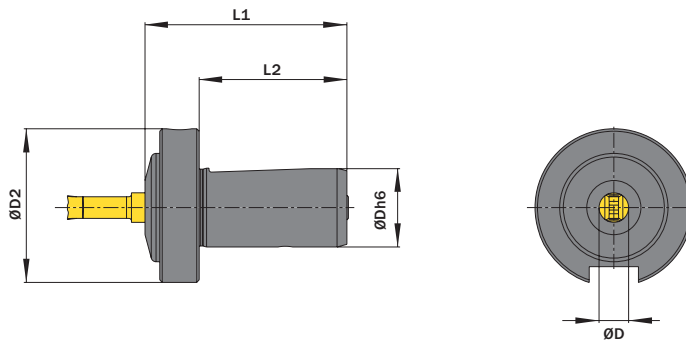


Abbildung zeigt / Drawing shows: A06.SB16-B

Für Nutstoßaggregat For broaching unit	ØD	ØDh6	Artikelnummer Part number	Webcode www.simtek.com/webcode	ØD2	L1	L2	Schraube Screw	Schraubenschlüssel Screw driver	Connectcode www.simtek.com/ccode
	mm	mm								
BENZ LinA/ EWS Slot	6,0	16,0	A06.SB16-B	AP46	32,0	41,0	30,0	A M6x7,5 T15F	T15F	BA06
BENZ LinA/ EWS Slot	7,0	16,0	A07.SB16-B	AP5A	32,0	41,0	30,0	A M6x7,5 T15F	T15F	BA07
BENZ LinA/ EWS Slot	10,0	16,0	A10.SB16-B	AUBG	32,0	50,0	30,0	A M6x7,5 T15F	T15F	BA10

Bestellbeispiel // Order example: **A10.SB16-B**

- Klemmhalter für weitere Nutstoßaggregate wie „Schwarzer V1“ oder „Schwarzer 2in1“ auf Anfrage erhältlich.
- Toolholders for other broaching units like „Schwarzer V1“ or „Schwarzer 2in1“ available upon request.

Stoßen von Längsnuten (DIN6885)

Toleranz P9. Geeignet ab Bohrungsdurchmesser 6,0 mm.

Keyway broaching (DIN6885)

Tolerance P9. For use in bores as of diameter 6,0 mm.

Schnittwerte (Start) // Cutting parameters (start) **Vc**
Seite/Page 696

Passende Klemmhalter auf Seite // Suitable toolholders on page
667, 668, 669, 670, 671

Vergleichbare Werkzeuge auf Seite // Similar tools on page
663

Bitte Hinweise im Anhang beachten // Please read add. notes
Wichtige Hinweise // Important hints (Seite/Page 733)

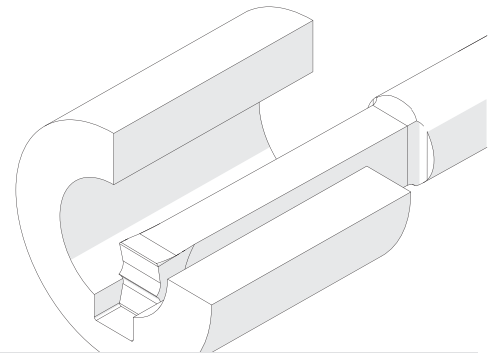
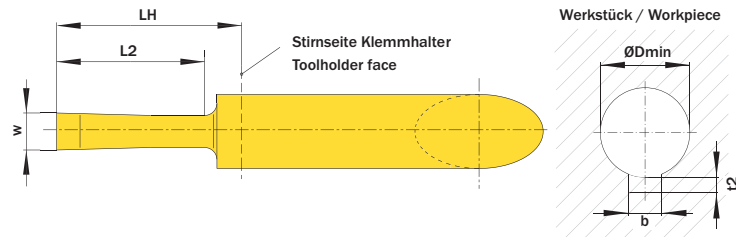
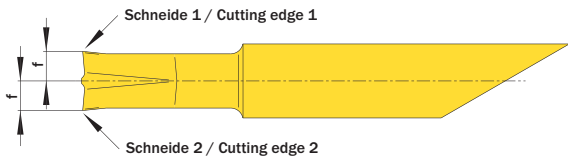


Illustration zeigt beispielhafte Anwendungsmöglichkeit mit ähnlichem Werkzeug. Image shows exemplary application possibility with similar tool.

2 Schneiden pro Einsatz
Cutting edges per insert

ØD	w	L2	R	Artikelnummer Part number	Webcode www.simtek.com/webcode	Schneidstoffgruppe Cutting Grade Group	b ^{P9}	ØDmin (Min. Bohrung) ØDmin (min. bore)	f	LH	t2 ^{+0,2}	Connectcode www.simtek.com/ccode
mm	mm	mm	mm				mm	mm	mm	mm	mm	
▼ ØD = 6,0 mm												
6,0	1,98	12,2	0,1	A06.0198.12.10 B	AA4P	CHGFK	2,0	6,0	2,4	15,0	1,0	BA06
6,0	2,98	12,2	0,1	A06.0298.12.10 B	APPX	CHGFK	3,0	8,0	2,4	15,0	1,4	BA06
▼ ØD = 7,0 mm												
7,0	3,97	15,2	0,1	A07.0397.15.10 B	AJ46	CHGFK	4,0	10,0	2,8	18,0	1,8	BA07
7,0	3,97	25,4	0,2	A07.0397.25.20 B	ANYE	CHGFK	4,0	10,0	2,8	28,0	1,8	BA07
7,0	3,97	40,6	0,2	A07.0397.40.20 B	AD8J	CHGFK	4,0	10,0	2,8	43,0	1,8	BA07
▼ ØD = 10,0 mm												
10,0	4,97	25,4	0,2	A10.0497.25.20 B	AA45	CHGFK	5,0	12,0	4,0	28,0	2,3	BA10
10,0	4,97	40,6	0,2	A10.0497.40.20 B	AFPN	CHGFK	5,0	12,0	4,0	43,0	2,3	BA10
10,0	5,97	40,6	0,2	A10.0597.40.20 B	AFX6	CHGFK	6,0	17,0	3,8	43,0	2,85	BA10

Bestellbeispiel // Order example: **A10.0497.40.20 B X800** (X800 = Schneidstoff // Grade)

Stoßen von Längsnuten (DIN6885)

Toleranz JS9. Geeignet ab Bohrungsdurchmesser 6,0 mm.

Keyway broaching (DIN6885)

Tolerance JS9. For use in bores as of diameter 6,0 mm.

Schnittwerte (Start) // Cutting parameters (start) **Vc**
Seite/Page 696

Passende Klemmhalter auf Seite // Suitable toolholders on page
667, 668, 669, 670, 671

Vergleichbare Werkzeuge auf Seite // Similar tools on page
663

Bitte Hinweise im Anhang beachten // Please read add. notes

Wichtige Hinweise // Important hints (Seite/Page 733)



SP HM JS9 Legende Legend **734**
Scan QR-Code Oder besuchen Sie // Or Visit www.simtek.info/cp/89

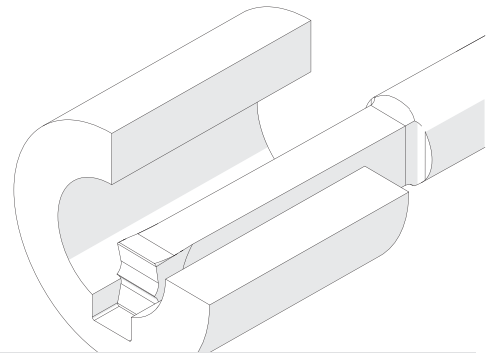
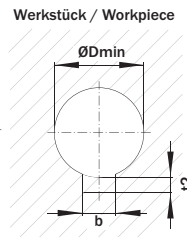
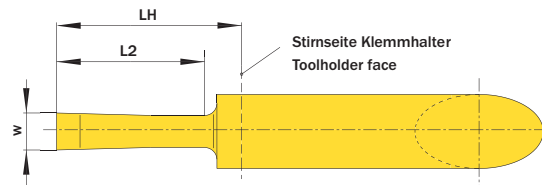
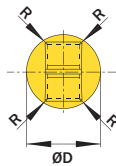
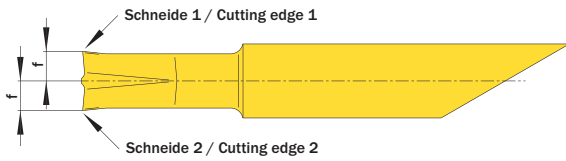


Illustration zeigt beispielhafte Anwendungsmöglichkeit mit ähnlichem Werkzeug. Image shows exemplary application possibility with similar tool.

2 Schneiden pro Einsatz // Cutting edges per insert

ØD	w	L2	R	Artikelnummer Part number	Webcode www.simtek.com/webcode	Schneidstoffgruppe Cutting Grade Group	b ^{JS9}	ØDmin (Min. Bohrung) ØDmin (min. bore)	f	LH	t2 ^{+0,2}	Connectcode www.simtek.com/code
mm	mm	mm	mm				mm	mm	mm	mm	mm	
▼ ØD = 6,0 mm												
6,0	2,0	12,2	0,1	A06.0200.12.10 B	AF66	CH G FK	2,0	6,0	2,4	15,0	1,0	BA06
6,0	3,0	12,2	0,1	A06.0300.12.10 B	ANGZ	CH G FK	3,0	8,0	2,4	15,0	1,4	BA06
▼ ØD = 7,0 mm												
7,0	4,0	15,2	0,1	A07.0400.15.10 B	AJYU	CH G FK	4,0	10,0	2,8	18,0	1,8	BA07
7,0	4,0	15,2	0,2	A07.0400.15.20 B	AE20	CH G FK	4,0	10,0	2,8	18,0	1,8	BA07
7,0	4,0	25,4	0,2	A07.0400.25.20 B	AGHJ	CH G FK	4,0	10,0	2,8	28,0	1,8	BA07
7,0	4,0	40,6	0,2	A07.0400.40.20 B	ACH7	CH G FK	4,0	10,0	2,8	43,0	1,8	BA07
▼ ØD = 10,0 mm												
10,0	5,0	25,4	0,2	A10.0500.25.20 B	AK2N	CH G FK	5,0	12,0	4,0	28,0	2,3	BA10
10,0	5,0	40,6	0,2	A10.0500.40.20 B	APD8	CH G FK	5,0	12,0	4,0	43,0	2,3	BA10
10,0	6,0	40,6	0,2	A10.0600.40.20 B	AC72	CH G FK	6,0	17,0	3,8	43,0	2,85	BA10

Bestellbeispiel // Order example: **A10.0500.25.20 B X800** (X800 = Schneidstoff // Grade)

Stoßen von Längsnuten (DIN6885)

Toleranz H9. Geeignet ab Bohrungsdurchmesser 6,0 mm.

Keyway broaching (DIN6885)

Tolerance H9. For use in bores as of diameter 6,0 mm.

Schnittwerte (Start) // Cutting parameters (start) **Vc**
Seite/Page 696

Passende Klemmhalter auf Seite // Suitable toolholders on page
667, 668, 669, 670, 671

Vergleichbare Werkzeuge auf Seite // Similar tools on page
663

Bitte Hinweise im Anhang beachten // Please read add. notes
Wichtige Hinweise // Important hints (Seite/Page 733)



SP **HM** **H9** Legende **734**
Legend
Scan QR-Code Oder besuchen Sie // Or Visit www.simtek.info/cp/260

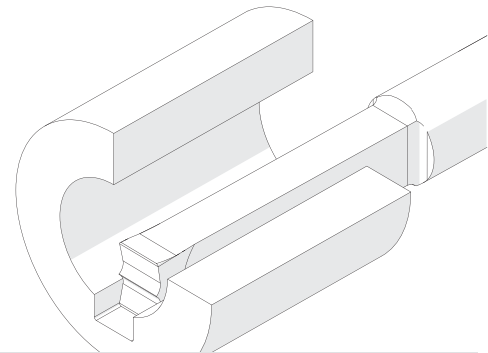
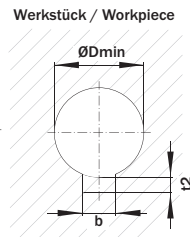
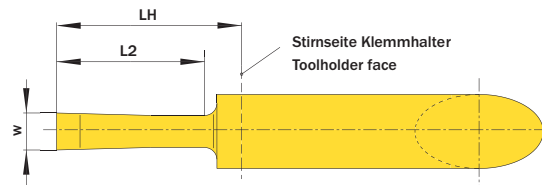
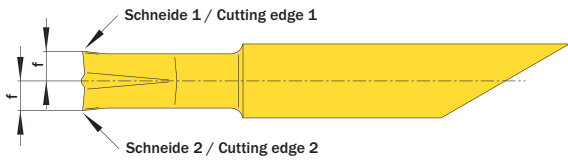


Illustration zeigt beispielhafte Anwendungsmöglichkeit mit ähnlichem Werkzeug. Image shows exemplary application possibility with similar tool.

2 Schneiden pro Einsatz // Cutting edges per insert

ØD	w	L2	R	Artikelnummer Part number	Webcode www.simtek.com/webcode	Schneidstoffgruppe Cutting Grade Group	b ^{H9}	ØDmin (Min. Bohrung) ØDmin (min. bore)	f	LH	t2 ^{+0,2}	Connectcode www.simtek.com/code
mm	mm	mm	mm				mm	mm	mm	mm	mm	
▼ ØD = 6,0 mm												
6,0	2,01	12,2	0,1	A06.0202.12.10 B	AJDC	CHGFK	2,0	6,0	2,4	15,0	1,0	BA06
6,0	3,01	12,2	0,1	A06.0302.12.10 B	AAZX	CHGFK	3,0	8,0	2,4	15,0	1,4	BA06
▼ ØD = 7,0 mm												
7,0	4,02	15,2	0,1	A07.0402.15.10 B	APSD	CHGFK	4,0	10,0	2,8	18,0	1,8	BA07
7,0	4,02	25,4	0,2	A07.0402.25.20 B	ADHG	CHGFK	4,0	10,0	2,8	28,0	1,8	BA07
7,0	4,02	40,6	0,2	A07.0402.40.20 B	AM3V	CHGFK	4,0	10,0	2,8	43,0	1,8	BA07
▼ ØD = 10,0 mm												
10,0	5,02	25,4	0,2	A10.0502.25.20 B	AGU3	CHGFK	5,0	12,0	4,0	28,0	2,3	BA10
10,0	5,02	40,6	0,2	A10.0502.40.20 B	AKWT	CHGFK	5,0	12,0	4,0	43,0	2,3	BA10
10,0	6,02	40,6	0,2	A10.0602.40.20 B	AFU9	CHGFK	6,0	17,0	3,8	43,0	2,85	BA10

Bestellbeispiel // Order example: **A07.0402.25.20 B X800** (X800 = Schneidstoff // Grade)

Stoßen von Längsnuten (Inch-Norm ANSI B17.2-1967)

Geeignet ab Bohrungsdurchmesser 6,0 mm.

Keyway broaching (According to Inch standard ANSI B17.2-1967)

For use in bores as of diameter 6,0 mm.

Schnittwerte (Start) / Cutting parameters (start) Vc
Seite/Page 696

Passende Klemmhalter auf Seite // Suitable toolholders on page
667, 668, 669, 670, 671

Bitte Hinweise im Anhang beachten // Please read add. notes
Wichtige Hinweise // Important hints (Seite/Page 733)



SP Legende
HM Legend **734**

Scan QR-Code Oder besuchen Sie // Or Visit
www.simtek.info/cp/1380

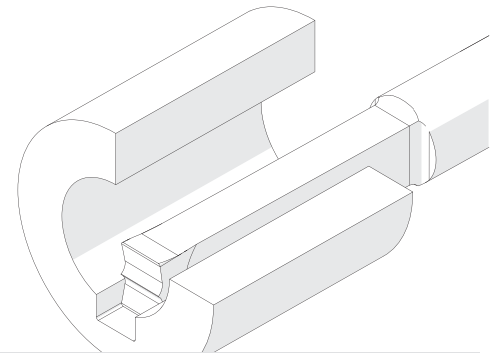
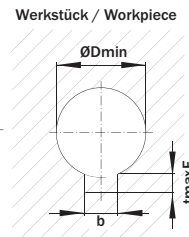
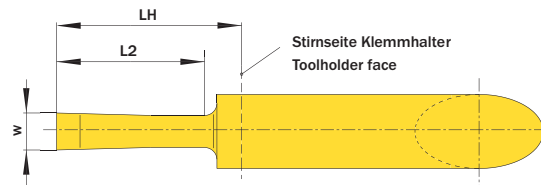
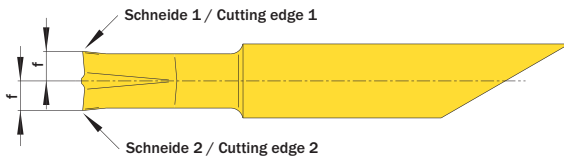


Illustration zeigt beispielhafte Anwendungsmöglichkeit mit ähnlichem Werkzeug.
Image shows exemplary application possibility with similar tool.

2 Schneiden pro Einsatz Cutting edges per insert

ØD	w	L2	R	Artikelnummer Part number	Webcode www.simtek.com/webcode	Schneidstoffgruppe Cutting Grade Group	b	ANSI B17.2-1967	ØDmin (Min. Bohrung) ØDmin (min. bore)	f	LH	tmaxE	Connectcode www.simtek.com/code	
mm	mm	mm	mm				mm		mm	mm	mm	mm		
▼ ØD = 6,0 mm														
6,0	1,639	12,2	0,102	A06.0158.12.10 B	A617	CHGFK	1,588	1/16	6,0	2,4	15,0	1,072	BA06	new inch
6,0	2,434	12,2	0,102	A06.0238.12.10 B	A619	CHGFK	2,381	3/32	6,0	2,4	15,0	1,471	BA06	new inch
6,0	3,226	15,2	0,102	A06.0317.15.10 B	A62B	CHGFK	3,175	1/8	6,0	2,4	18,0	1,867	BA06	new inch
▼ ØD = 7,0 mm														
7,0	4,021	15,2	0,102	A07.0396.15.10 B	A62D	CHGFK	3,969	5/32	6,5	2,4	15,0	2,263	BA07	new inch
7,0	4,021	25,4	0,203	A07.0396.25.20 B	A62F	CHGFK	3,969	5/32	7,2	2,8	28,0	2,263	BA07	new inch
7,0	4,814	25,4	0,203	A07.0476.25.20 B	A62H	CHGFK	4,762	3/16	7,2	2,5	28,0	2,659	BA07	new inch
▼ ØD = 10,0 mm														
10,0	4,021	40,6	0,203	A10.0396.40.20 B	A62K	CHGFK	3,969	5/32	8,9	3,8	43,0	2,263	BA10	new inch
10,0	4,813	40,6	0,203	A10.0476.40.20 B	A62N	CHGFK	4,762	3/16	8,9	3,6	43,0	2,659	BA10	new inch
10,0	5,609	40,6	0,203	A10.0555.40.20 B	A62Q	CHGFK	5,556	7/32	10,0	4,0	43,0	3,056	BA10	new inch

Bestellbeispiel // Order example: **A10.0555.40.20 B X800** (X800 = Schneidstoff // Grade)

Innensechskant

Stoßen von Innensechskantprofilen.


Hexagon-Socket

Hexagon socket broaching.

Schnittwerte (Start) Vc
Cutting parameters (start) **Seite/Page 696**

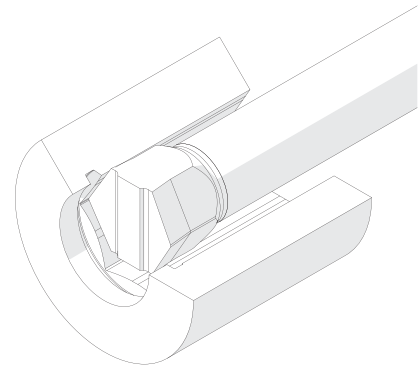
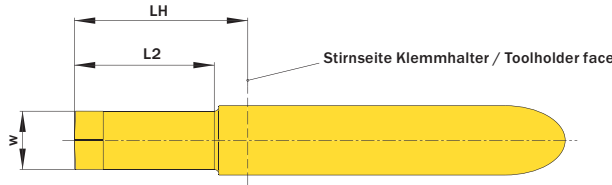
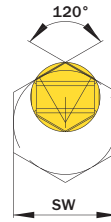
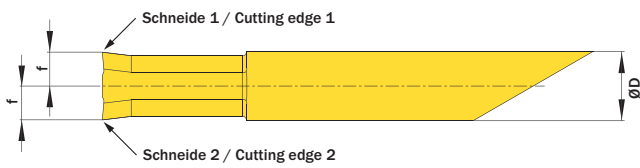
Passende Klemmhalter auf Seite // Suitable toolholders on page
667, 668, 669, 670, 671

Bitte Hinweise im Anhang beachten // Please read add. notes
Wichtige Hinweise // Important hints (Seite/Page 733)



SP Legende
HM Legend **734**

Scan QR-Code Oder besuchen Sie // Or Visit
www.simtek.info/cp/883



2 Schneiden pro Einsatz Cutting edges per insert

ØD	L2	Artikelnummer Part number	Webcode www.simtek.com/webcode	Schneidstoffgruppe Cutting Grade Group	f	LH	SW von	SW bis	w	Connectcode www.simtek.com/code
mm	mm				mm	mm	mm	mm	mm	
▼ ØD = 6,0 mm										
6,0	4,5	A06.H025.05.20 B	AXU7	CHGFK	0,98	13,0	2,5	2,5	1,5	BA06
6,0	5,8	A06.H030.06.25 B	AXU6	CHGFK	1,23	13,0	3,0	3,0	1,8	BA06
6,0	7,0	A06.H035.07.30 B	AXU5	CHGFK	1,48	13,0	3,5	3,5	2,1	BA06
6,0	9,1	A06.H040.09.35 B	ASD0	CHGFK	1,73	13,0	4,0	5,0	3,0	BA06
6,0	12,2	A06.H060.12.59 B	ASD1	CHGFK	2,73	18,0	6,0	9,0	5,0	BA06
▼ ØD = 7,0 mm										
7,0	25,4	A07.H100.25.92 B	AXB0	CHGFK	4,6	28,0	10,0	15,0	8,0	BA07
▼ ØD = 10,0 mm										
10,0	25,4	A10.H100.25.99 B	ASD2	CHGFK	4,95	28,0	10,0	15,0	8,0	BA10

Bestellbeispiel // Order example: **A06.H060.12.59 B X800** (X800 = Schneidstoff // Grade)

Stoßen von Nutaußenkantenfasen

Entgraten von Längsnuten.

Chamfer Broaching

Deburring of key ways.

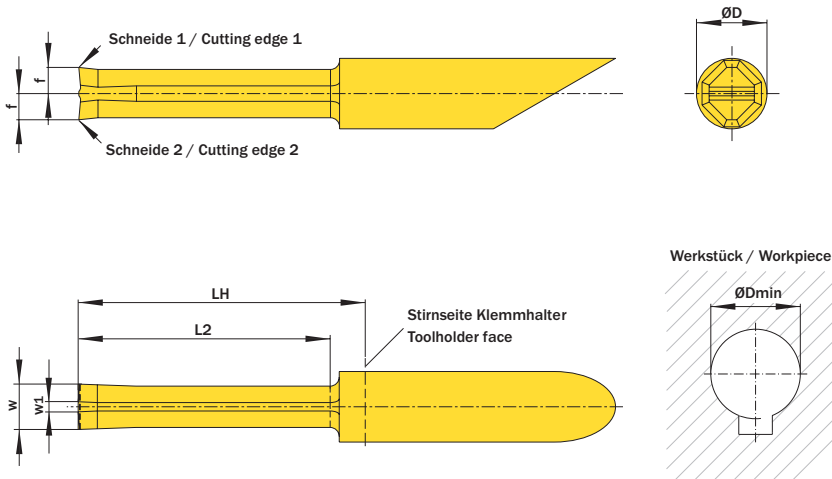
Schnittwerte (Start) Vc
Cutting parameters (start) **Seite/Page 696**

Passende Klemmhalter auf Seite // Suitable toolholders on page
667, 668, 669, 670, 671

Bitte Hinweise im Anhang beachten // Please read add. notes
Wichtige Hinweise // Important hints (Seite/Page 733)

SP Legende
HM Legend **734**

Scan QR-Code Oder besuchen Sie // Or Visit www.simtek.info/cp/1112



2 Schneiden pro Einsatz Cutting edges per insert

ØD	L2	ØDmin (Min. Bohrung) ØDmin (min. bore)	Artikelnummer Part number	Webcode www.simtek.com/webcode	Schneidstoffgruppe Cutting grade Group	f	LH	w	w1	Connectcode www.simtek.com/code	upd
mm	mm	mm				mm	mm	mm	mm		
▼ ØD = 7,0 mm											
7,0	15,9	6,0	A07.4545.15.60 BF	AYD8	CHGFK	2,6	18,0	4,5	1,0	BA07	upd
7,0	25,4	6,0	A07.4545.25.60 BF	AYD7	CHGFK	2,6	28,0	4,5	1,0	BA07	upd
▼ ØD = 10,0 mm											
10,0	25,4	9,0	A10.4545.25.90 BF	AYD6	CHGFK	3,8	28,0	6,3	2,0	BA10	upd
10,0	40,6	9,0	A10.4545.40.90 BF	AYD5	CHGFK	3,8	43,0	6,3	2,0	BA10	upd

Bestellbeispiel // Order example: **A07.4545.25.60 BF X800** (X800 = Schneidstoff // Grade)

simcutBF
SIMTEK broaching type BF



Ab Seite // As of page

663

Anwendungsübersicht
Application overview

Klemmhalter für konventionelles Nutstoßen

Geeignet für das konventionelle Nutstoßen von Standard- und Sonderprofilen auf geeigneten CNC-Maschinen.

Toolholder for conventional Broaching

For conventional broaching of standard and special profiles on capable CNC-machines.

Anzugsmoment (Schraube) // Tightening torque (screw)

4,5 Nm

Vergleichbare Werkzeuge auf Seite // Similar tools on page
665

Bitte Hinweise im Anhang beachten // Please read add. notes

MASTER (Seite/Page 732), Wichtige Hinweise // Important hints (Seite/Page 733)



Legende Legend **734**



Scan QR-Code

Oder besuchen Sie // Or Visit www.simtek.info/cp/463

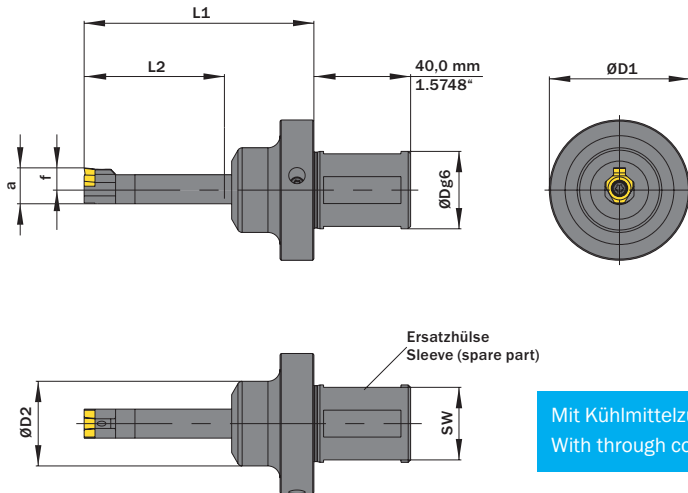


Abbildung zeigt / Drawing shows: F10.SB32.56 ZB

ØDg6	L2	Artikelnummer Part number	Webcode www.simtek.com/webcode	a	ØDmin (Min. Bohrung) ØDmin (min. bore)	ØD1	ØD2	f	L1	SW	Ersatzklemmhalter Toolholder (spare part)	Ersatzhülse Sleeve (spare part)	Schraube Screw	Schraubenschlüssel Screw driver	Connectcode www.simtek.com/code
mm	mm			mm	mm	mm	mm	mm	mm	mm					
▼ ØDg6 = 25,0 mm															
25,0	56,0	F10.SB25.56 ZB	ASCV	14,85	17,0	58,0	35,0	8,85	94,5	23,0	F10.05.56.12	F10.1225.56 SB	F M4x11 T15F	T15F	BF10
25,0	56,0	F10.SB25.56.14 ZB	A63B	13,0	14,0	58,0	35,0	7,0	100,0	23,0	F10.03.56.12	F10.1225.56 SB	F M4x11 T15F	T15F	BF10.05.14 <small>NEW</small>
25,0	80,0	F10.SB25.80 ZB	ASCW	14,85	17,0	58,0	35,0	8,85	114,0	23,0	F10.05.80.12	F10.1225.80 SB	F M4x11 T15F	T15F	BF10
▼ ØDg6 = 32,0 mm															
32,0	56,0	F10.SB32.56 ZB	ASCX	14,85	17,0	58,0	35,0	8,85	94,5	30,0	F10.05.56.12	F10.1232.56 SB	F M4x11 T15F	T15F	BF10
32,0	80,0	F10.SB32.80 ZB	ASCY	14,85	17,0	58,0	35,0	8,85	114,0	30,0	F10.05.80.12	F10.1232.80 SB	F M4x11 T15F	T15F	BF10

Bestellbeispiel // Order example: **F10.SB25.56 ZB**

Klemmhalter für konventionelles Nutstoßen

Geeignet für das konventionelle Nutstoßen von Standard- und Sonderprofilen auf geeigneten CNC-Maschinen.

Toolholder for conventional Broaching

For conventional broaching of standard and special profiles on capable CNC-machines.

Anzugsmoment (Schraube) // Tightening torque (screw)

4,5 Nm

Vergleichbare Werkzeuge auf Seite // Similar tools on page
665

Bitte Hinweise im Anhang beachten // Please read add. notes

MASTER (Seite/Page 732), Wichtige Hinweise // Important hints (Seite/Page 733)

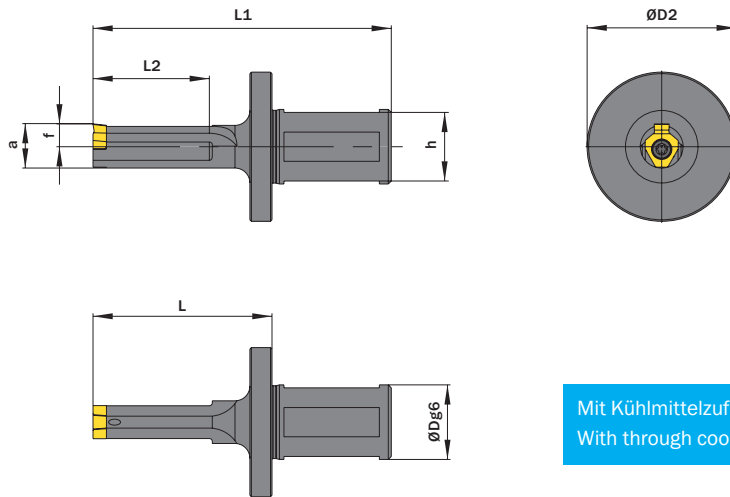


Legende
Legend **734**



Scan
QR-Code

Oder besuchen Sie // Or Visit
www.simtek.info/cp/462



Mit Kühlmittelzufuhr
With through coolant supply

Abbildung zeigt / Drawing shows: F10.05.40.25

L2	ØDg6	Artikelnummer Part number	Webcode www.simtek.com/webcode	a	ØDmin (Min. Bohrung) ØDmin (min. bore)	ØD2	f	h	L	L1	Schraube Screw	Schraubenschlüssel Screw driver	Connectcode www.simtek.com/code
mm	mm			mm	mm	mm	mm	mm	mm	mm			
▼ ØDmin (Min. Bohrung) // ØDmin (min. bore) = 14,0 mm													
40,1	25,0	F10.03.40.25.14	A63F	13,0	14,0	50,0	6,5	24,0	60,0	100,0	FM4x11 T15F	T15F	BF10.05.14
40,1	25,4	F10.05.40.1.000	A1EB	13,0	14,0	50,8	6,5	23,4	60,0	100,0	FM4x11 T15F	T15F	BF10.08.14
40,1	25,0	F10.05.40.25.14	A083	13,0	14,0	50,0	6,5	23,0	60,0	100,0	FM4x11 T15F	T15F	BF10.08.14
▼ ØDmin (Min. Bohrung) // ØDmin (min. bore) = 17,0 mm													
40,0	25,0	F10.05.40.25	AQH6	14,8	17,0	50,0	7,65	23,0	60,0	100,0	FM4x11 T15F	T15F	BF10
40,0	32,0	F10.05.40.32	AQH7	14,8	17,0	58,0	7,65	30,0	60,0	100,0	FM4x11 T15F	T15F	BF10

Bestellbeispiel // Order example: **F10.05.40.25**

Klemmhalter für konventionelles Nutstoßen

Geeignet für das konventionelle Nutstoßen von Standard- und Sonderprofilen auf geeigneten CNC-Maschinen.

Toolholder for conventional broaching

For conventional broaching of standard and special profiles on capable CNC-machines.

Anzugsmoment (Schraube) // Tightening torque (screw)

6,0 Nm

Vergleichbare Werkzeuge auf Seite // Similar tools on page
665

Bitte Hinweise im Anhang beachten // Please read add. notes

MASTER (Seite/Page 732), Wichtige Hinweise // Important hints (Seite/Page 733)



TW
ST

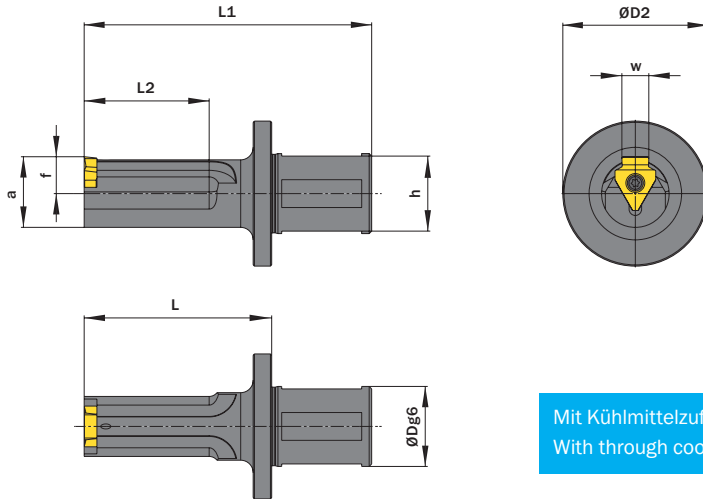


Legende
Legend **734**



Scan
QR-Code

Oder besuchen Sie // Or Visit
www.simtek.info/cp/145



Mit Kühlmittelzufuhr
With through coolant supply

Abbildung zeigt / Drawing shows: F39.10.50.32

w	L2	ØDg6	Artikelnummer Part number	Webcode www.simtek.com/webcode	a	ØDmin (Min. Bohrung) ØDmin (min. bore)	ØD2	f	h	L	L1	Schraube Screw	Schraubenschlüssel Screw driver	Connectcode www.simtek.com/code
mm	mm	mm			mm	mm	mm	mm	mm	mm	mm			
▼ w = 6,0 mm														
6,0	50,0	25,0	F39.06.50.25	ATYV	20,3	22,0	50,0	10,5	23,0	75,0	115,0	F M5x13 T20R	T20R	BF12.06
6,0	70,0	25,0	F39.06.70.25	ATYU	20,3	22,0	50,0	10,5	23,0	95,0	135,0	F M5x13 T20R	T20R	BF12.06
▼ w = 8,0 mm														
8,0	50,0	25,0	F39.08.50.25	AJ0D	20,3	22,0	50,0	10,5	23,0	75,0	115,0	F M5x13 T20R	T20R	BF12.08
8,0	50,8	25,4	F39.08.51.1.000	A1EC	20,3	22,0	50,0	10,5	23,4	75,0	115,0	F M5x13 T20R	T20R	BF12.08 <small>inch</small>
8,0	75,0	25,0	F39.08.75.25	AUGC	20,3	22,0	50,0	10,5	23,0	100,0	140,0	F M5x13 T20R	T20R	BF12.08
8,0	76,2	25,4	F39.08.76.1.000	A4TT	20,3	22,0	50,0	10,5	23,4	75,0	115,0	F M5x13 T20R	T20R	BF12.08 <small>new inch</small>
▼ w = 10,0 mm														
10,0	100,0	32,0	F39.10.10.32	A0ZQ	28,5	30,0	58,0	14,75	30,0	125,0	185,0	F M5x13 T20R	T20R	BF12.10
10,0	50,0	32,0	F39.10.50.32	AKJG	28,5	30,0	58,0	14,75	30,0	75,0	115,0	F M5x13 T20R	T20R	BF12.10
10,0	50,8	31,75	F39.10.51.1.250	A1ED	28,5	30,0	58,0	14,75	30,0	75,0	115,0	F M5x13 T20R	T20R	BF12.10 <small>inch</small>
10,0	75,0	32,0	F39.10.75.32	ANWV	28,5	30,0	58,0	14,75	30,0	100,0	140,0	F M5x13 T20R	T20R	BF12.10
10,0	76,2	31,75	F39.10.76.1.250	A1EE	28,5	30,0	58,0	14,75	29,75	100,0	140,0	F M5x13 T20R	T20R	BF12.10 <small>inch</small>
▼ w = 12,0 mm														
12,0	100,0	32,0	F39.12.10.32	A0ZP	36,0	38,0	58,0	18,5	30,0	125,0	185,0	F M5x13 T20R	T20R	BF12.12
12,0	50,0	32,0	F39.12.50.32	AHHB	36,0	38,0	58,0	18,5	30,0	75,0	115,0	F M5x13 T20R	T20R	BF12.12
12,0	75,0	32,0	F39.12.75.32	AFT7	36,0	38,0	58,0	18,5	30,0	100,0	140,0	F M5x13 T20R	T20R	BF12.12
12,0	76,2	31,75	F39.12.76.1.250	A1EF	36,0	38,0	58,0	18,5	29,75	100,0	140,0	F M5x13 T20R	T20R	BF12.12 <small>inch</small>
▼ w = 16,0 mm														
16,0	125,0	32,0	F39.16.12.32	A63D	46,0	50,0	60,0	23,5	31,0	150,0	225,0	F M5x13 T20R	T20R	BF12.16 <small>new</small>

Bestellbeispiel // Order example: **F39.08.75.25**

Klemmhalter für Nutstoßaggregate

Geeignet für das Nutstoßen von Standard- und Sonderprofilen auf Nutstoßaggregat „Schwarzer 2in1“.

Toolholder for broaching units

For broaching of standard and special profiles on broaching unit „Schwarzer 2in1“.

Anzugsmoment (Schraube) // Tightening torque (screw)

4,5 Nm

Vergleichbare Werkzeuge auf Seite // Similar tools on page
664

Bitte Hinweise im Anhang beachten // Please read add. notes

**Wichtige Hinweise // Important hints (Seite/Page 733),
MASTER (Seite/Page 732),**



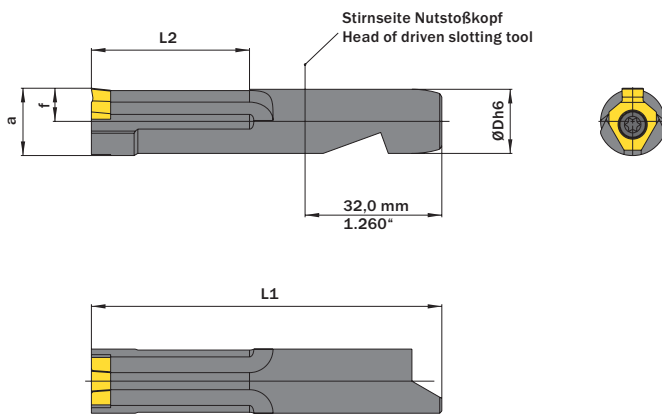
Legende
Legend

734



Scan
QR-Code

Oder besuchen Sie // Or Visit
www.simtek.info/cp/458



Schwarzer Version 1 Aufnahme auf Anfrage erhältlich.
Schwarzer Version 1 fixation available upon request.

Abbildung zeigt / Drawing shows: F10.SB15.36-S

Für Nutstoßaggregat For broaching unit	ØDh6	L2	Artikelnummer Part number	Webcode www.simtek.com/webcode	a	ØDmin (Min. Bohrung) ØDmin (min. bore)	f	L1	Schraube Screw	Schraubenschlüssel Screw driver	Connectcode www.simtek.com/code
	mm	mm			mm	mm	mm	mm	mm	mm	
Schwarzer 2in1	15,0	19,0	F10.SB15.18-S	AP5B	15,75	17,0	7,75	64,0	FM4x11 T15F	T15F	BF10
Schwarzer 2in1	15,0	27,0	F10.SB15.26-S	AP5F	15,75	17,0	7,75	72,0	FM4x11 T15F	T15F	BF10
Schwarzer 2in1	15,0	37,0	F10.SB15.36-S	AP4X	15,75	17,0	7,75	82,0	FM4x11 T15F	T15F	BF10
Schwarzer 2in1	15,0	43,0	F10.SB15.42-S	AS6G	15,75	17,0	7,75	88,0	FM4x11 T15F	T15F	BF10

Bestellbeispiel // Order example: **F10.SB15.36-S**

Klemmhalter für Nutstoßaggregate

Geeignet für das Nutstoßen von Standard- und Sonderprofilen auf Nutstoßaggregat „Benz LinA“, „Benz LinA 4.0“, „EWS Slot“ und „EWS P20“.

Toolholder for broaching units

For broaching of standard and special profiles on broaching unit „Benz LinA“, „Benz LinA 4.0“, „EWS Slot“ and „EWS P20“.

Anzugsmoment (Schraube) // Tightening torque (screw)

4,5 Nm

Vergleichbare Werkzeuge auf Seite // Similar tools on page
664

Bitte Hinweise im Anhang beachten // Please read add. notes

**MASTER (Seite/Page 732),
Wichtige Hinweise // Important hints (Seite/Page 733)**



Legende
Legend **734**



Scan
QR-Code

Oder besuchen Sie // Or Visit
www.simtek.info/cp/459

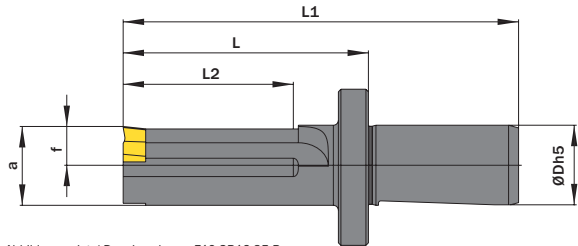


Abbildung zeigt / Drawing shows: F10.SB16.35-B

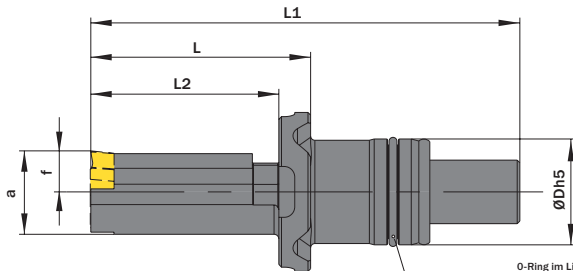
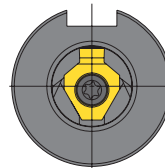
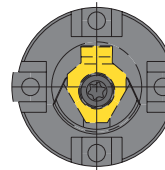


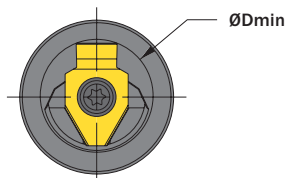
Abbildung zeigt / Drawing shows: F10.SB20.35-B IC

0-Ring im Lieferumfang enthalten
0-Ring included in scope of delivery
Bestellnummer // part number:
ORING 16X1,5 FPM80 GR

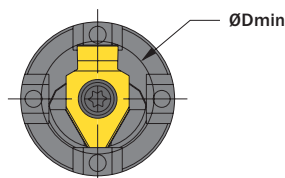


Für Nutstoßaggregat For broaching unit	ØDh5 mm	L2 mm	Mit Kühlmittelzufuhr With through coolant supply	Artikelnummer Part number	Webcode www.simtek.com/webcode	a	ØDmin (Min. Bohrung) ØDmin (min. bore)	f	L	L1	Prismen-Fixiersystem Variante // Prism fixation system variant	Schraube Screw	Schraubenschlüssel Screw driver	Connectcode www.simtek.com/ccode	
						mm	mm								
BENZ LinA / EWS Slot	16,0	35,0	Nein / No	F10.SB16.35-B	AP4Y	15,75	17,0	7,75	49,0	79,0	-	FM4x11 T15F	T15F	BF10	upd
BENZ LinA / EWS Slot	16,0	53,0	Nein / No	F10.SB16.53-B	A0YC	15,75	17,0	7,75	67,5	97,5	-	FM4x11 T15F	T15F	BF10	upd
BENZ LinA 4.0 / EWS P20	20,0	35,5	Ja / Yes	F10.SB20.35-B IC	A2ZG	15,75	17,0	7,75	41,5	81,0	1+3	FM4x11 T15F	T15F	BF10	upd
BENZ LinA 4.0 / EWS P20	20,0	54,5	Ja / Yes	F10.SB20.53-B IC	A4N5	15,75	17,0	7,75	60,5	100,0	1+3	FM4x11 T15F	T15F	BF10	new

Bestellbeispiel // Order example: **F10.SB16.35-B**



Prismen-Fixiersystem Variante 1
Prism fixation system variant 1



Prismen-Fixiersystem Variante 3
Prism fixation system variant 3
Spannschrauben liegen dem Aggregat bei.
Clamping screws are included with the unit.

Klemmhalter für Nutstoßaggregate

Geeignet für das Nutstoßen von Standard- und Sonderprofilen auf Nutstoßaggregat „Benz LinA 4.0“ und „EWS P20“.
Empfohlene maximale Schneidenbreite: 12,0 mm.

Toolholder for broaching units

For broaching of standard and special profiles on broaching unit „Benz LinA 4.0“ and „EWS Slot P20“. Recommended maximum cutting edge width: 12,0 mm.

Anzugsmoment (Schraube) // Tightening torque (screw)

6,0 Nm

Bitte Hinweise im Anhang beachten // Please read add. notes

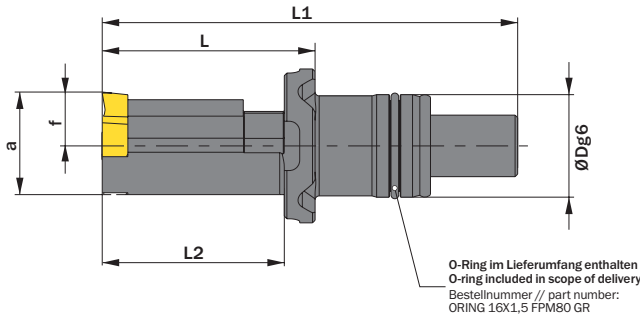
MASTER (Seite/Page 732),
Wichtige Hinweise // Important hints (Seite/Page 733),



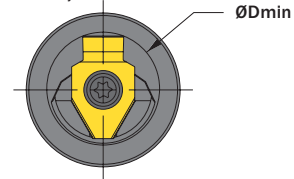
Legende
Legend **734**

Scan
QR-Code

Oder besuchen Sie // Or Visit
www.simtek.info/cp/1383



Prismen-Fixiersystem Variante 1
Prism fixation system variant 1



Prismen-Fixiersystem Variante 3 // Prism fixation system variant 3
Spannschrauben liegen dem Aggregat bei. // Clamping screws are included with the unit.

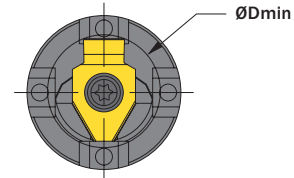


Abbildung zeigt / Drawing shows: F39.SB20.22.35-B IC

Für Nutstoßaggregat For broaching unit	ØDg6		L2	Artikelnummer Part number	Webcode www.simtek.com/webcode	a	ØDmin (Min. Bohrung) ØDmin (min. bore)	f	L	L1	Prismen-Fixiersystem Variante // Prism fixation system variant	Schraube Screw	Schraubenschlüssel Screw driver	Connectcode www.simtek.com/code	
	mm	mm													
BENZ LinA 4.0/EWS P20	20,0	35,5	F39.SB20.22.35-B IC	A62T	10,5	22,0	41,5	81,0	81,0	1+3	F M5x13 T20R	T20R	BF12.06	new	
BENZ LinA 4.0/EWS P20	20,0	54,5	F39.SB20.22.53-B IC	A62V	10,5	22,0	20,0	60,5	100,0	1+3	F M5x13 T20R	T20R	BF12.06	new	
BENZ LinA 4.0/EWS P20	20,0	35,5	F39.SB20.30.35-B IC	A62X	13,0	30,0	27,0	41,5	81,0	1	F M5x13 T20R	T20R	BF12.10	new	
BENZ LinA 4.0/EWS P20	20,0	54,5	F39.SB20.30.53-B IC	A62Z	13,0	30,0	27,0	60,5	100,0	1	F M5x13 T20R	T20R	BF12.10	new	
BENZ LinA 4.0/EWS P20	20,0	54,5	F39.SB20.38.53-B IC	A621	15,5	38,0	30,5	60,5	100,0	1	F M5x13 T20R	T20R	BF12.12	new	

Bestellbeispiel // Order example: **F39.SB20.38.53-B IC**

Klemmhalter für Nutstoßaggregate

Geeignet für das Nutstoßen von Standard- und Sonderprofilen auf Nutstoßaggregat „WTO“.

Toolholder for Broaching Units

For broaching of Standard and special profiles on broaching units „WTO“.

Anzugsmoment (Schraube) // Tightening torque (screw)

4,5 Nm

Bitte Hinweise im Anhang beachten // Please read add. notes

MASTER (Seite/Page 732)



Legende
Legend

734



Scan
QR-Code

Oder besuchen Sie // Or Visit
www.simtek.info/cp/1268

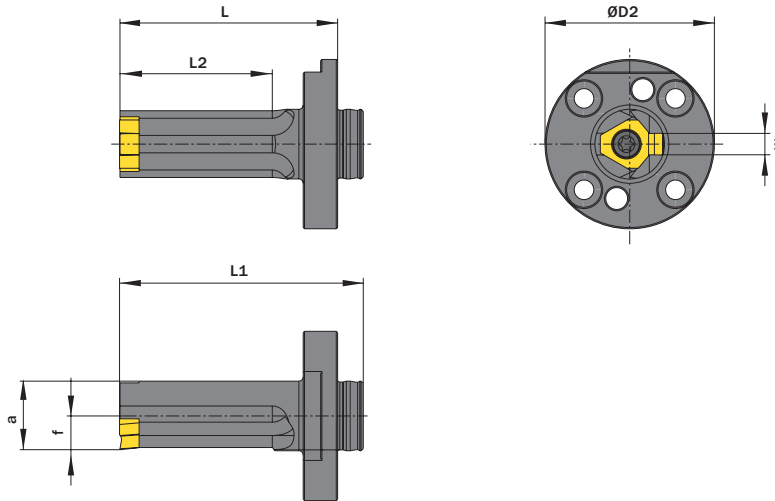


Abbildung zeigt / Drawing shows: F10.SB16.35 W

Für Nutstoßaggregat For broaching unit	L2 mm	Artikelnummer Part number	Webcode www.simtek.com/webcode	a	ØDmin (Min. Bohrung) ØDmin (min. bore)	ØD2	f	L	L1	w	Schraube Screw	Schraubenschlüssel Screw driver	Connectcode www.simtek.com/code
				mm	mm	mm	mm	mm	mm	mm	mm	mm	
wto	35,0	F10.SB16.35-W	A1SB	15,75	17,0	38,9	7,75	50,0	55,9	4,0	FM4x11 T15F	T15F	BF10

Bestellbeispiel // Order example: **F10.SB16.35-W**

Stoßen von Längsnuten (DIN6885)

Toleranz P9. Geeignet ab Bohrungsdurchmesser 17,0 mm.

Keyway broaching (DIN6885)


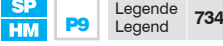
Tolerance P9. For use in bores as of diameter 17,0 mm.


Schnittwerte (Start) // Cutting parameters (start) **Vc**
Seite/Page 696

Passende Klemmhalter auf Seite // Suitable toolholders on page
679, 680, 682, 683, 685

Vergleichbare Werkzeuge auf Seite // Similar tools on page
663

Bitte Hinweise im Anhang beachten // Please read add. notes
Wichtige Hinweise // Important hints (Seite/Page 733)

 Scan QR-Code Oder besuchen Sie // Or Visit www.simtek.info/cp/464

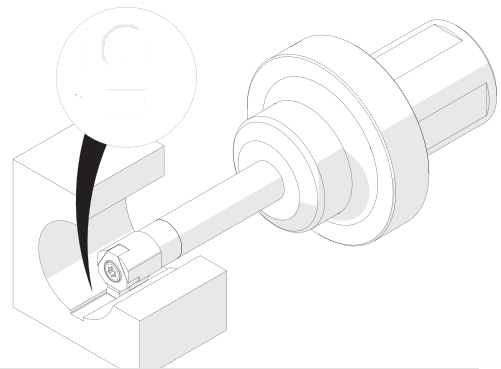
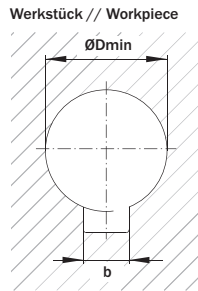
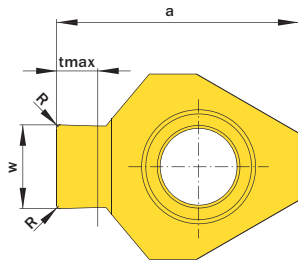


Illustration zeigt beispielhafte Anwendungsmöglichkeit mit ähnlichem Werkzeug.
Image shows exemplary application possibility with similar tool.

w	R	Artikelnummer Part number	Webcode www.simtek.com/webcode	Schneidstoffgruppe Cutting Grade Group	a	b ^{P9}	ØDmin (Min. Bohrung) ØDmin (min. bore)	h	tmax	Connectcode www.simtek.com/code
mm	mm				mm	mm	mm	mm	mm	
4,97	0,2	F10.0498.02 B	AQ0T	CHGFK	14,5	5,0	17,0	4,4	2,8	BF10
5,97	0,2	F10.0598.02 B	AQ0U	CHGFK	14,5	6,0	17,0	4,4	2,8	BF10
7,97	0,2	F10.0796.02 B	AT82	CHGFK	14,5	8,0	22,0	4,4	4,1	BF10

Bestellbeispiel // Order example: **F10.0796.02 B X800** (X800 = Schneidstoff // Grade)

Der Artikel F10.0796.02 B ist für den Einsatz auf Nutstoßaggregate nur bedingt geeignet. Bitte stimmen Sie die technische Machbarkeit mit unserer technischen Fachberatung ab: +49 7473 9517-140 oder support@simtek.com

The article F10.0796.02 B has a limited suitability for the use in push-slotting aggregates. Please contact our technical department in order to proof the technical feasibility: +49 7473 9517-140 or support@simtek.com

Stoßen von Längsnuten (DIN6885)

Toleranz P9. Geeignet ab Bohrungsdurchmesser 22,0 mm.

Keyway broaching (DIN6885)

Tolerance P9. For use in bores as of diameter 22,0 mm.

Schnittwerte (Start) // Cutting parameters (start) **Vc**
Seite/Page 696

Passende Klemmhalter auf Seite // Suitable toolholders on page
681, 684

Vergleichbare Werkzeuge auf Seite // Similar tools on page
663

Bitte Hinweise im Anhang beachten // Please read add. notes

Wichtige Hinweise // Important hints (Seite/Page 733)



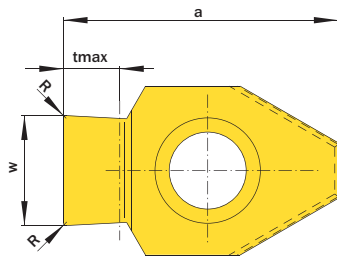
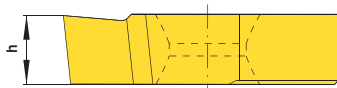
SP
HM

P9

Legende
Legend **734**

Scan
QR-Code

Oder besuchen Sie // Or Visit
www.simtek.info/cp/148



Werkstück // Workpiece

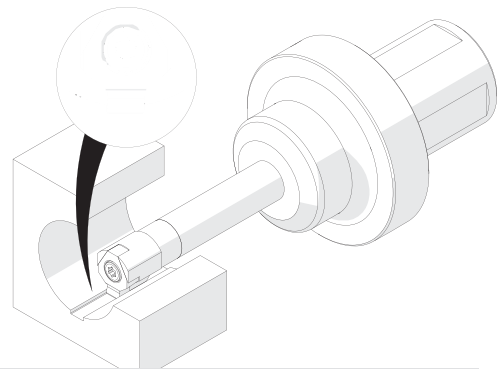
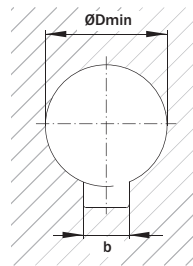


Illustration zeigt beispielhafte Anwendungsmöglichkeit mit ähnlichem Werkzeug.
Image shows exemplary application possibility with similar tool.

w	R	Artikelnummer Part number	Webcode www.simtek.com/webcode	Schneidstoffgruppe Cutting Grade Group	a	b ^{P9}	ØDmin (Min. Bohrung) ØDmin (min. bore)	h	tmax	Connectcode www.simtek.com/ccode
mm	mm				mm	mm	mm	mm	mm	
▼ Connectcode = BF12.08										
7,98	0,2	F12.0796.02 B	AJ2Q	CHGFK	20,0	8,0	22,0	5,0	4,1	BF12.08
▼ Connectcode = BF12.10										
9,98	0,3	F12.0996.03 B	AN3J	CHGFK	21,5	10,0	30,0	5,0	4,2	BF12.10
▼ Connectcode = BF12.12										
11,97	0,3	F12.1196.03 B	ANEM	CHGFK	21,5	12,0	38,0	5,0	5,7	BF12.12
13,97	0,3	F12.1396.03 B	A18K	CHGFK	21,5	14,0	40,0	5,0	6,8	BF12.12

Bestellbeispiel // Order example: **F12.0796.02 B X800** (X800 = Schneidstoff // Grade)

Stoßen von Längsnuten (DIN6885)

Toleranz JS9. Geeignet ab Bohrungsdurchmesser 14,0 mm.

Keyway broaching (DIN6885)

Tolerance JS9. For use in bores as of diameter 14,0 mm.

Schnittwerte (Start) Cutting parameters (start)	Vc Seite/Page 696
--	----------------------

Passende Klemmhalter auf Seite // Suitable toolholders on page
679, 680, 682, 683, 685

Vergleichbare Werkzeuge auf Seite // Similar tools on page
663

Bitte Hinweise im Anhang beachten // Please read add. notes

Wichtige Hinweise // Important hints (Seite/Page 733)



SP
HM

JS9

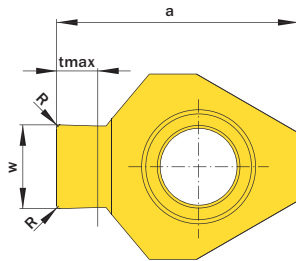
Legende
Legend

734



Scan
QR-Code

Oder besuchen Sie // Or Visit
www.simtek.info/cp/465



Werkstück // Workpiece

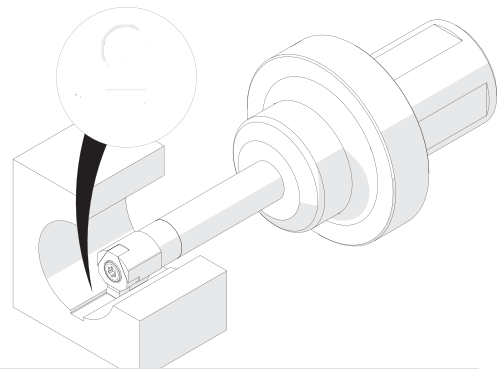
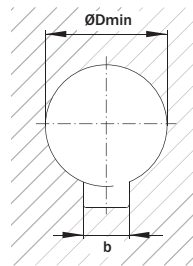


Illustration zeigt beispielhafte Anwendungsmöglichkeit mit ähnlichem Werkzeug.
Image shows exemplary application possibility with similar tool.

w	R	Artikelnummer Part number	Webcode www.simtek.com/webcode	Schneidstoffgruppe Cutting Grade Group	a	b ^{JS9}	ØDmin (Min. Bohrung) ØDmin (min. bore)	h	tmax	Connectcode www.simtek.com/ccode
mm	mm				mm	mm	mm	mm	mm	
▼ ØDmin (Min. Bohrung) // ØDmin (min. bore) = 14,0 mm										
5,0	0,2	F10.0500.02.14 B	A082	CHGFK	12,5	5,0	14,0	4,4	2,8	BF10.08.14
▼ ØDmin (Min. Bohrung) // ØDmin (min. bore) = 17,0 mm										
5,0	0,2	F10.0500.02 B	AQ05	CHGFK	14,5	5,0	17,0	4,4	2,8	BF10
6,0	0,2	F10.0600.02 B	AQ0Q	CHGFK	14,5	6,0	17,0	4,4	2,8	BF10
▼ ØDmin (Min. Bohrung) // ØDmin (min. bore) = 22,0 mm										
8,0	0,2	F10.0800.02 B	AT83	CHGFK	14,5	8,0	22,0	4,4	4,1	BF10

Bestellbeispiel // Order example: **F10.0800.02 B X800** (X800 = Schneidstoff // Grade)

Der Artikel F10.0800.02 B ist für den Einsatz auf Nutstoßaggregate nur bedingt geeignet. Bitte stimmen Sie die technische Machbarkeit mit unserer technischen Fachberatung ab: +49 7473 9517-140 oder support@simtek.com

The article F10.0800.02 B has a limited suitability for the use in push-slotting aggregates. Please contact our technical department in order to proof the technical feasibility: +49 7473 9517-140 or support@simtek.com

Stoßen von Längsnuten (DIN6885)

Toleranz JS9. Geeignet ab Bohrungsdurchmesser 22,0 mm.

Keyway broaching (DIN6885)

Tolerance JS9. For use in bores as of diameter 22,0 mm.

Schnittwerte (Start) // Cutting parameters (start) **Vc**
Seite/Page 696

Passende Klemmhalter auf Seite // Suitable toolholders on page
681, 684

Vergleichbare Werkzeuge auf Seite // Similar tools on page
663

Bitte Hinweise im Anhang beachten // Please read add. notes

Wichtige Hinweise // Important hints (Seite/Page 733)



SP
HM

JS9

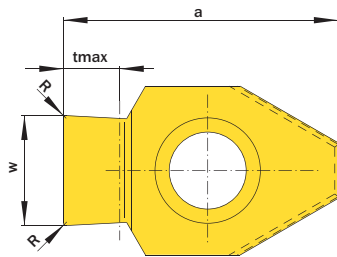
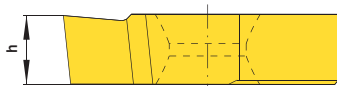
Legende
Legend

734



Scan
QR-Code

Oder besuchen Sie // Or Visit
www.simtek.info/cp/146



Werkstück // Workpiece

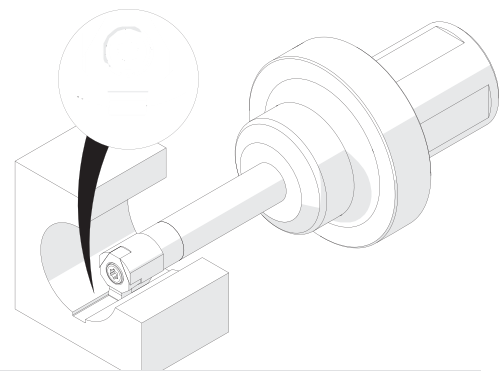
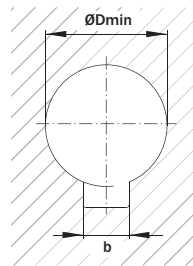


Illustration zeigt beispielhafte Anwendungsmöglichkeit mit ähnlichem Werkzeug.
Image shows exemplary application possibility with similar tool.

w	R	Artikelnummer Part number	Webcode www.simtek.com/webcode	Schneidstoffgruppe Cutting Grade Group	a	b JS9	ØDmin (Min. Bohrung) ØDmin (min. bore)	h	tmax	Connectcode www.simtek.com/code
mm	mm				mm	mm	mm	mm	mm	
▼ Connectcode = BF12.08										
8,0	0,2	F12.0800.02 B	ACKQ	CHGFK	20,0	8,0	22,0	5,0	4,1	BF12.08
8,0	0,5	F12.0800.02.05 B	APQ6	CHGFK	20,0	8,0	22,0	5,0	4,1	BF12.08
▼ Connectcode = BF12.10										
10,0	0,3	F12.1000.03 B	AFVD	CHGFK	21,5	10,0	30,0	5,0	4,2	BF12.10
10,0	0,5	F12.1000.03.05 B	AJUV	CHGFK	21,5	10,0	30,0	5,0	4,2	BF12.10
▼ Connectcode = BF12.12										
12,0	0,3	F12.1200.03 B	AD7S	CHGFK	21,5	12,0	38,0	5,0	5,7	BF12.12
12,0	0,5	F12.1200.03.05 B	AG8M	CHGFK	21,5	12,0	38,0	5,0	5,7	BF12.12
12,0	0,5	F12.1200.05 B	ANBE	CHGFK	21,5	12,0	38,0	5,0	8,5	BF12.12
14,0	0,3	F12.1400.03 B	A18J	CHGFK	21,5	14,0	40,0	5,0	6,8	BF12.12
16,0	0,3	F12.1600.03 B	A2T1	CHGFK	21,5	16,0	38,0	5,0	6,3	BF12.12

Bestellbeispiel // Order example: **F12.0800.02 B X800** (X800 = Schneidstoff // Grade)

Stoßen von Längsnuten (DIN6885)

Toleranz H9. Geeignet ab Bohrungsdurchmesser 17,0 mm.

Keyway broaching (DIN6885)

Tolerance H9. For use in bores as of diameter 17,0 mm.

Schnittwerte (Start) // Cutting parameters (start) **Vc**
Seite/Page 696

Passende Klemmhalter auf Seite // Suitable toolholders on page
679, 680, 682, 683, 685

Vergleichbare Werkzeuge auf Seite // Similar tools on page
663

Bitte Hinweise im Anhang beachten // Please read add. notes

Wichtige Hinweise // Important hints (Seite/Page 733)



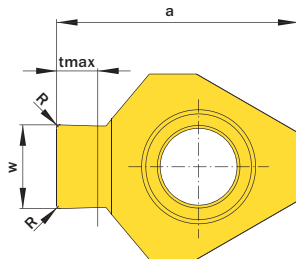
SP
HM

H9

Legende
Legend **734**

Scan
QR-Code

Oder besuchen Sie // Or Visit
www.simtek.info/cp/466



Werkstück // Workpiece

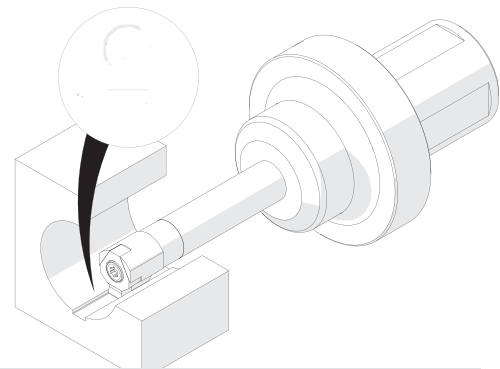
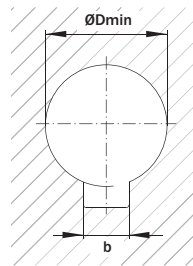


Illustration zeigt beispielhafte Anwendungsmöglichkeit mit ähnlichem Werkzeug.
Image shows exemplary application possibility with similar tool.

w	R	Artikelnummer Part number	Webcode www.simtek.com/webcode	Schneidstoffgruppe Cutting Grade Group	a	b ^{H9}	ØDmin (Min. Bohrung) ØDmin (min. bore)	h	tmax	Connectcode www.simtek.com/code
mm	mm				mm	mm	mm	mm	mm	
5,02	0,2	F10.0502.02 B	AQ0V	CHGFK	14,5	5,0	17,0	4,4	2,8	BF10
6,02	0,2	F10.0602.02 B	AQ0W	CHGFK	14,5	6,0	17,0	4,4	2,8	BF10
8,02	0,2	F10.0802.02 B	AT84	CHGFK	14,5	8,0	22,0	4,4	4,1	BF10

Bestellbeispiel // Order example: **F10.0602.02 B X800** (X800 = Schneidstoff // Grade)

Der Artikel F10.0802.02 B ist für den Einsatz auf Nutstoßaggregate nur bedingt geeignet. Bitte stimmen Sie die technische Machbarkeit mit unserer technischen Fachberatung ab: +49 7473 9517-140 oder support@simtek.com

The article F10.0802.02 B has a limited suitability for the use in push-slotting aggregates. Please contact our technical department in order to proof the technical feasibility: +49 7473 9517-140 or support@simtek.com

Stoßen von Längsnuten (DIN6885)

Toleranz H9. Geeignet ab Bohrungsdurchmesser 22,0 mm.

Keyway broaching (DIN6885)

Tolerance H9. For use in bores as of diameter 22,0 mm.

Schnittwerte (Start) // Cutting parameters (start) **Vc**
Seite/Page 696

Passende Klemmhalter auf Seite // Suitable toolholders on page
681, 684

Vergleichbare Werkzeuge auf Seite // Similar tools on page
663

Bitte Hinweise im Anhang beachten // Please read add. notes

Wichtige Hinweise // Important hints (Seite/Page 733)



SP
HM

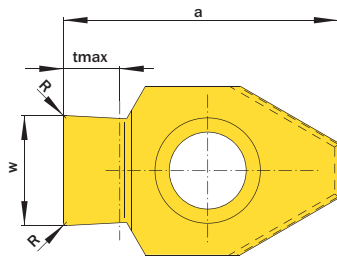
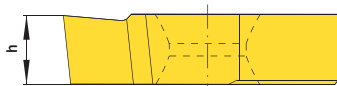
H9

Legende
Legend **734**



Scan
QR-Code

Oder besuchen Sie // Or Visit
www.simtek.info/cp/264



Werkstück // Workpiece

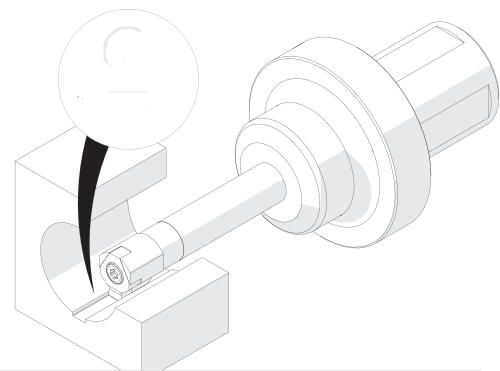
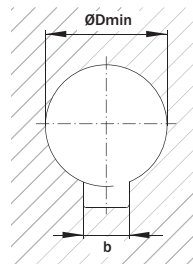


Illustration zeigt beispielhafte Anwendungsmöglichkeit mit ähnlichem Werkzeug.
Image shows exemplary application possibility with similar tool.

w	R	Artikelnummer Part number	Webcode www.simtek.com/webcode	Schneidstoffgruppe Cutting Grade Group	a	b ^{H9}	ØDmin (Min. Bohrung) ØDmin (min. bore)	h	tmax	Connectcode www.simtek.com/ccode
mm	mm				mm	mm	mm	mm	mm	
8,02	0,2	F12.0802.02 B	AEV2	CHGFK	20,0	8,0	22,0	5,0	4,1	BF12.08
10,02	0,3	F12.1002.03 B	AEX3	CHGFK	21,5	10,0	30,0	5,0	4,2	BF12.10
12,02	0,3	F12.1202.03 B	AJQ5	CHGFK	21,5	12,0	38,0	5,0	5,7	BF12.12

Bestellbeispiel // Order example: **F12.1002.03 B X800** (X800 = Schneidstoff // Grade)

Stoßen von Längsnuten (Inch-Norm ANSI B17.2-1967)

Geeignet ab Bohrungsdurchmesser 14,0 mm.

Keyway broaching (According to Inch standard ANSI B17.2-1967)

For use in bores as of diameter 14,0 mm.

Schnittwerte (Start) / Cutting parameters (start) Vc
Seite/Page 696

Passende Klemmhalter auf Seite // Suitable toolholders on page
679, 680, 682, 683, 685

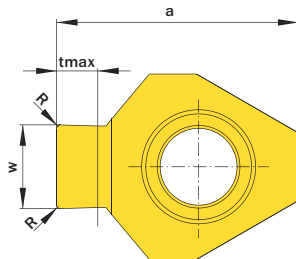
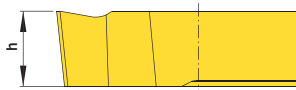
Bitte Hinweise im Anhang beachten // Please read add. notes

MASTER (Seite/Page 732), Wichtige Hinweise // Important hints (Seite/Page 733)



SP Legende
HM Legend **734**

Scan QR-Code Oder besuchen Sie // Or Visit
www.simtek.info/cp/1373



Werkstück // Workpiece

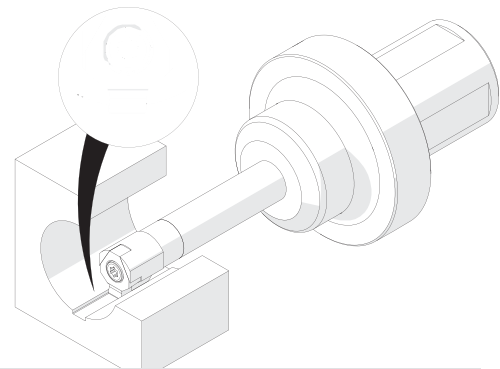
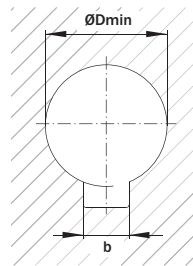


Illustration zeigt beispielhafte Anwendungsmöglichkeit mit ähnlichem Werkzeug.
Image shows exemplary application possibility with similar tool.

w	R	Artikelnummer Part number	Webcode www.simtek.com/webcode	Schneidstoffgruppe Cutting Grade Group	a	b	ANSI B17.2-1967	ØDmin (Min. Bohrung) ØDmin (min. bore)	h	tmax	Connectcode www.simtek.com/code	
mm	mm				mm	mm		mm	mm	mm		
▼ ØDmin (Min. Bohrung) // ØDmin (min. bore) = 14,0 mm												
3,226	0,102	F10.0317.01.14 B	A6YH	CHGF K	12,5	3,175	1/8	14,0	4,4	1,867	BF10.05.14	new inch
4,013	0,102	F10.0396.01.14 B	A6YK	CHGF K	12,5	3,962	5/32	14,0	4,4	2,263	BF10.05.14	new inch
4,813	0,203	F10.0476.02.14 B	A6YN	CHGF K	12,5	4,762	3/16	14,0	4,4	2,659	BF10.08.14	new inch
▼ ØDmin (Min. Bohrung) // ØDmin (min. bore) = 17,0 mm												
4,813	0,203	F10.0476.02.17 B	A6YX	CHGF K	14,5	4,762	3/16	17,0	4,4	2,659	BF10	new inch
5,608	0,203	F10.0555.02.17 B	A6YZ	CHGF K	14,5	5,556	7/32	17,0	4,4	3,056	BF10	new inch
6,401	0,203	F10.0635.02.17 B	A6Y1	CHGF K	14,5	6,35	1/4	17,0	4,4	3,454	BF10	new inch

Bestellbeispiel // Order example: **F10.0555.02.17 B X800** (X800 = Schneidstoff // Grade)

Stoßen von Längsnuten (Inch-Norm ANSI B17.2-1967)

Geeignet ab Bohrungsdurchmesser 22,0 mm.

Keyway broaching (According to Inch Standard ANSI B17.2-1967)

For use in bores as of diameter 22,0 mm.

Schnittwerte (Start) // Cutting parameters (start) **Vc**
Seite/Page 696

Passende Klemmhalter auf Seite // Suitable toolholders on page
681, 684

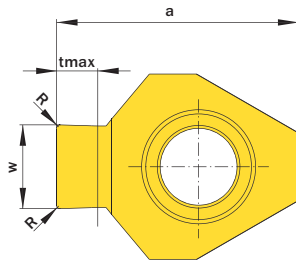
Bitte Hinweise im Anhang beachten // Please read add. notes

MASTER (Seite/Page 732), Wichtige Hinweise // Important hints (Seite/Page 733)



SP Legende
HM Legend **734**

Scan QR-Code Oder besuchen Sie // Or Visit
www.simtek.info/cp/1374



Werkstück // Workpiece

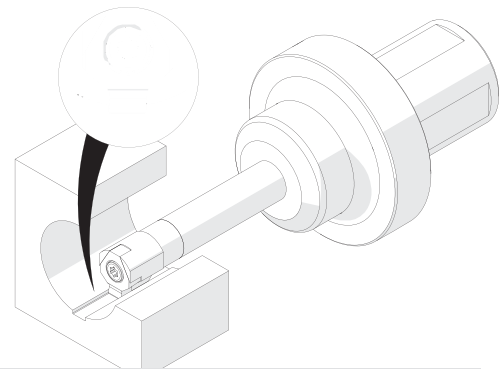
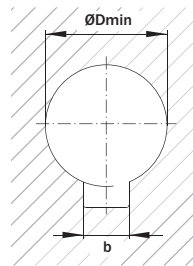


Illustration zeigt beispielhafte Anwendungsmöglichkeit mit ähnlichem Werkzeug.
Image shows exemplary application possibility with similar tool.

w	R	Artikelnummer Part number	Webcode www.simtek.com/webcode	Schneidstoffgruppe Cutting Grade Group	a	b	ANSI B17.2-1967	ØDmin (Min. Bohrung) ØDmin (min. bore)	h	tmax	Connectcode www.simtek.com/code	
mm	mm				mm	mm		mm	mm	mm		
▼ ØDmin (Min. Bohrung) // ØDmin (min. bore) = 22,0 mm												
7,195	0,203	F12.0714.02.22 B	A6Y3	CHGFK	20,0	7,144	9/32	22,0	5,0	4,089	BF12.08	<small>new</small> inch
7,989	0,203	F12.0793.02.22 B	A6Y5	CHGFK	20,0	7,938	5/16	22,0	5,0	4,247	BF12.08	<small>new</small> inch
▼ ØDmin (Min. Bohrung) // ØDmin (min. bore) = 30,0 mm												
9,576	0,305	F12.0952.03.30 B	A6Y7	CHGFK	21,5	9,525	3/8	30,0	5,0	5,042	BF12.10	<small>new</small> inch
▼ ØDmin (Min. Bohrung) // ØDmin (min. bore) = 38,0 mm												
11,164	0,305	F12.1111.03.38 B	A6Y9	CHGFK	21,5	11,112	7/16	38,0	5,0	5,834	BF12.12	<small>new</small> inch
12,751	0,305	F12.1270.03.38 B	A6ZB	CHGFK	21,5	12,7	1/2	38,0	5,0	6,629	BF12.12	<small>new</small> inch
▼ ØDmin (Min. Bohrung) // ØDmin (min. bore) = 40,0 mm												
14,339	0,406	F12.1428.04.40 B	A6ZD	CHGFK	21,5	14,288	9/16	40,0	5,0	7,422	BF12.12	<small>new</small> inch
15,926	0,406	F12.1587.04.40 B	A6ZF	CHGFK	21,5	15,875	5/8	40,0	5,0	8,217	BF12.12	<small>new</small> inch
▼ ØDmin (Min. Bohrung) // ØDmin (min. bore) = 54,0 mm												
17,514	0,406	F12.1746.04.54 B	A6ZH	CHGFK	21,5	17,462	11/16	54,0	5,0	9,009	BF12.16	<small>new</small> inch
19,101	0,406	F12.1905.04.54 B	A6ZK	CHGFK	21,5	19,05	3/4	54,0	5,0	9,804	BF12.16	<small>new</small> inch

Bestellbeispiel // Order example: **F12.1905.04.54 B X800** (X800 = Schneidstoff // Grade)

Stoßen von Nutaußenkantenfasen

Entgraten von Längsnuten.

Chamfer Broaching

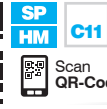
Deburring of key ways.

Schnittwerte (Start) Vc
Cutting parameters (start) **Seite/Page 696**

Passende Klemmhalter auf Seite // Suitable toolholders on page
679, 680, 682, 683, 685

Bitte Hinweise im Anhang beachten // Please read add. notes

Wichtige Hinweise // Important hints (Seite/Page 733)



Legende **734**
Legend



Scan QR-Code

Oder besuchen Sie // Or Visit
www.simtek.info/cp/1113

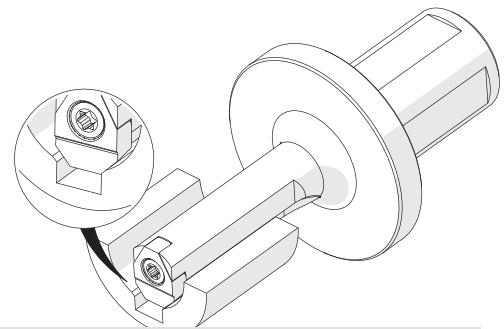
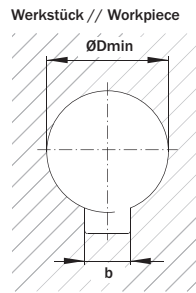
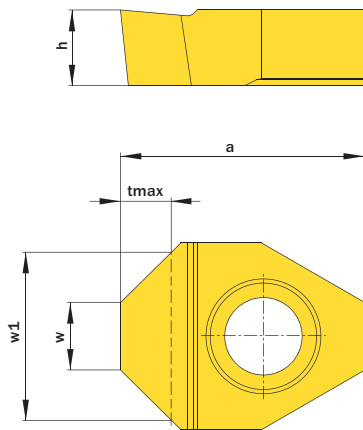


Illustration zeigt beispielhafte Anwendungsmöglichkeit mit ähnlichem Werkzeug.
Image shows exemplary application possibility with similar tool.

w	b ^{C11}	ØDmin (Min. Bohrung) ØDmin (min. bore)	Artikelnummer Part number	Webcode www.simtek.com/webcode	Schneidstoffgruppe Cutting grade Group	a	h	tmax	w1	Connectcode www.simtek.com/code
mm	mm	mm				mm	mm	mm	mm	
4,0	6,0	17,0	F10.4545.40.06.17 BF	AYEA	CHGFK	14,5	4,5	3,15	10,3	BF10
5,5	8,0	22,0	F10.4545.55.08.22 BF	AYD9	CHGFK	14,5	4,5	2,4	10,3	BF10

Bestellbeispiel // Order example: **F10.4545.40.06.17 BF X800** (X800 = Schneidstoff // Grade)

Stoßen von Nutaußenkantenfasen

Entgraten von Längsnuten.


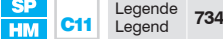
Chamfer Broaching


Deburring of key ways.

Schnittwerte (Start) Vc
Cutting parameters (start) **Seite/Page 696**

Passende Klemmhalter auf Seite // Suitable toolholders on page
681, 684

Bitte Hinweise im Anhang beachten // Please read add. notes
Wichtige Hinweise // Important hints (Seite/Page 733)

 Scan QR-Code Oder besuchen Sie // Or Visit www.simtek.info/cp/1114

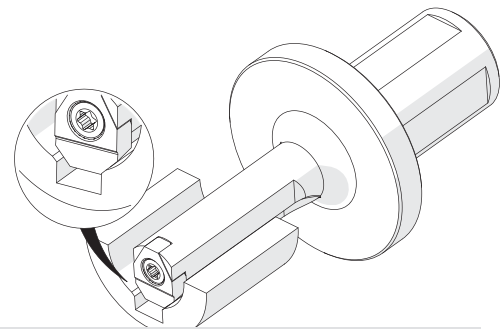
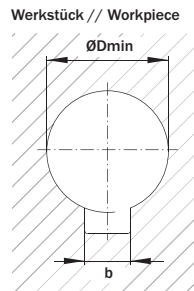
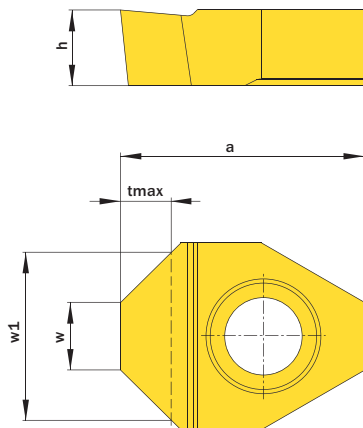


Illustration zeigt beispielhafte Anwendungsmöglichkeit mit ähnlichem Werkzeug.
Image shows exemplary application possibility with similar tool.

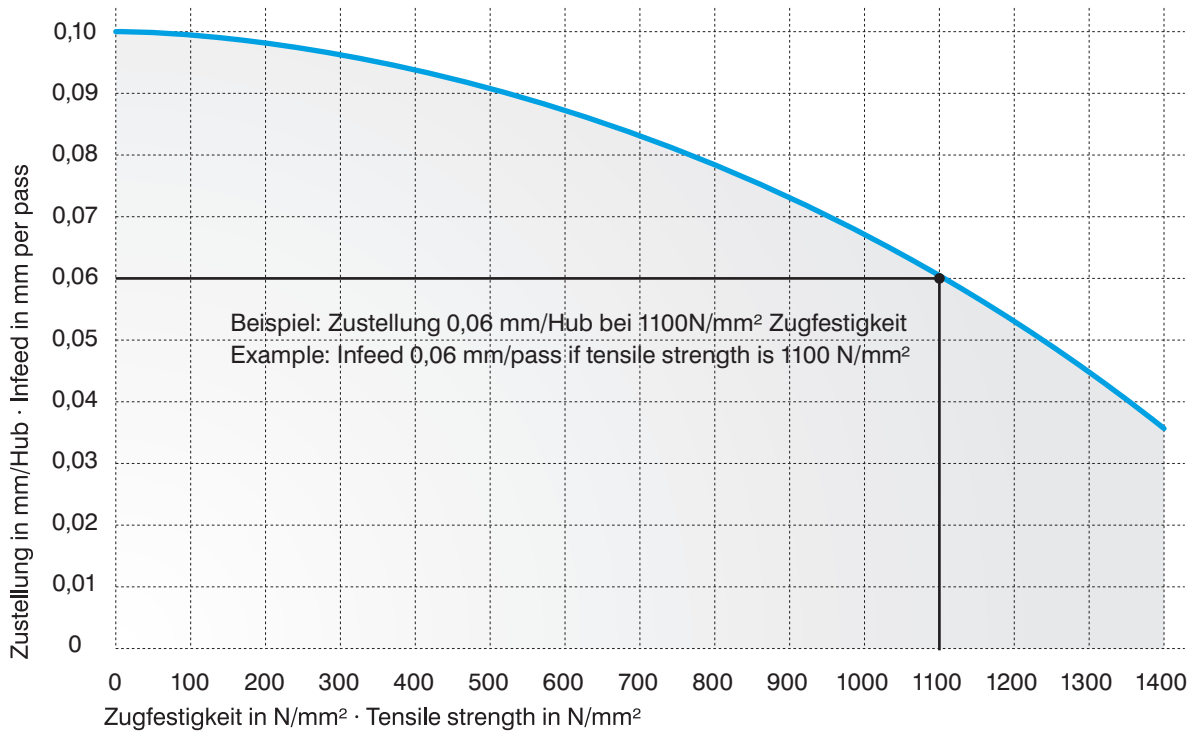
w	Artikelnummer Part number	Webcode www.simtek.com/webcode	Schneidstoffgruppe Cutting Grade Group	a	b ^{C11}	ØDmin (Min. Bohrung) ØDmin (min. bore)	h	tmax	w1	Connectcode www.simtek.com/ccode
mm				mm	mm	mm	mm	mm	mm	
5,0	F12.4545.50.08.22 BF	AYED	CH G FK	20,0	8,0	22,0	5,0	3,25	11,5	BF12.08
6,5	F12.4545.65.10.30 BF	AYEE	CH G FK	21,5	10,0	30,0	5,0	4,5	15,5	BF12.10
8,5	F12.4545.85.12.38 BF	AYEF	CH G FK	21,5	12,0	38,0	5,0	3,5	15,5	BF12.12

Bestellbeispiel // Order example: **F12.4545.50.08.22 BF X800** (X800 = Schneidstoff // Grade)

Schnittdaten für Nutstoßen Cutting Parameters for Broaching

Dieses Diagramm stellt einen Annäherungswert dar, welcher in Abhängigkeit der Anwendungs- und gegebenen Maschinenbedingungen abweichen kann.

This chart should give you an approximate value for the cutting parameters. The values can vary depending on machine conditions and workpiece kind.

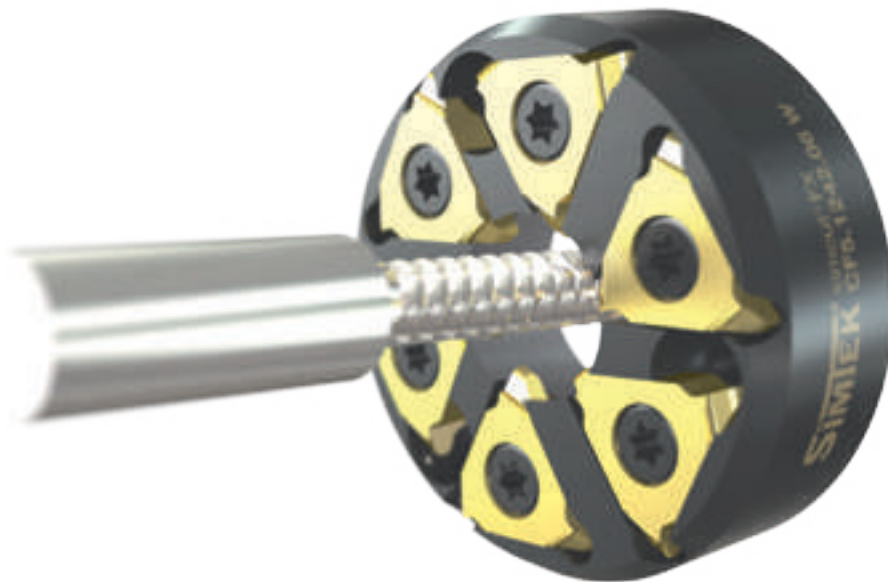


Die Schnittgeschwindigkeit wird maßgeblich durch die Maschinenbedingungen vorgegeben.

The cutting speed is mainly influenced by the machine conditions and machine capabilities.

Das Werkzeugsystem simcut FX The Tool System simcut FX

Gewindewirbelwerkzeuge für die Medizintechnik und für schwer spanbare Materialien.
Thread whirling applications in medical technology and in difficult-to-machine materials.



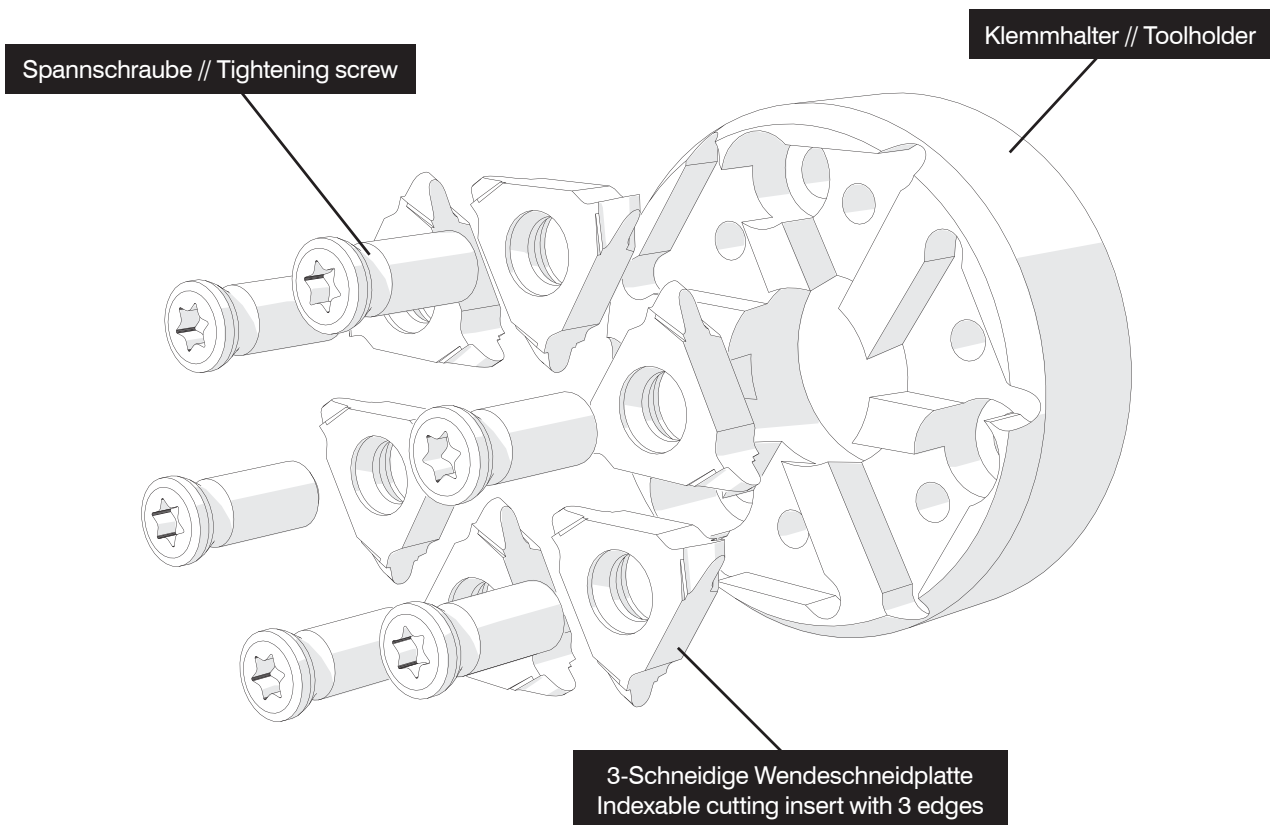
Werkzeuggruppe aus hochpräzisen, dreischneidigen Hartmetall-Wendeschneidplatten mit ausgesuchten Beschichtungen und präzisen Wirbelringen. Besonders geeignet auch für schwer spanbare Materialien.

Tool group of high precision, three-edged carbide inserts with special coatings and matching whirling ring. Suitable for „Difficult-to-machine materials“ too.

Das System im Detail The System Details

Bitte beachten Sie die allgemeinen Gebrauchshinweise auf Seite
Please read the general instructions for use on page

733



Wirbelringe verfügbar für folgende Maschinentypen Thread whirling rings available for the following machine types

- Für Tornos-Maschinen
- Für Citizen-Maschinen mit Jarvis-Spindel
- Für Citizen-Maschinen mit PCM-Spindel
- Für WTO-Aggregate
- Für Star-Maschinen
- Für Tugami-Maschinen
- Für Hanwha
- For Tornos-machines
- For Citizen-machines with Jarvis-spindle
- For Citizen-machines with PCM-spindle
- For WTO-whirling units
- For Star-machines
- For Tugami-machines
- For Hanwha

Gewindewirbelkopf „Tornos“

Für Tornos-Maschinen.

Thread Whirling Head „Tornos“

For Tornos machines.

Anzugsmoment (Schraube) // Tightening torque (screw)

4,5 Nm



TW
ST

Legende
Legend

734



Scan
QR-Code

Oder besuchen Sie // Or Visit
www.simtek.info/cp/929

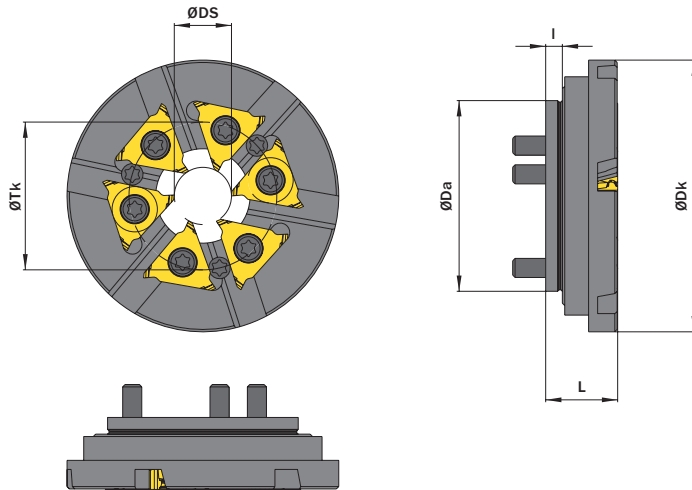


Abbildung zeigt / Drawing shows: CF5.AA40.12.06

ØDS	Anzahl Plattensitze Number of insert seats	Artikelnummer Part number	Webcode www.simtek.com/webcode	ØDa	ØDk	I	L	ØTk	Aggregat Whirling units	Schraube Screw	Schraubenschlüssel Screw driver	Connectcode www.simtek.com/code
mm				mm	mm	mm	mm	mm				
12,0	6	CF5.AA40.12.06	AS32	40,0	57,0	3,5	15,0	31,0	306101/307087	F M4x8,5 T15F	T15F	CF5.L.4.1
12,0	6	CF5.AA50.12.06	AZU8	50,0	67,0	3,5	15,4	40,0	417627	F M4x8,5 T15F	T15F	CF5.L.4.1

Bestellbeispiel // Order example: **CF5.AA50.12.06**

Befestigungsschraube // Fastening screw: D M4x12 T15F

Gewindewirbelkopf „WTO“

Für WTO-Aggregate.

Thread Whirling Head „WTO“

For WTO whirling units.

Anzugsmoment (Schraube) // Tightening torque (screw)

4,5 Nm



TW
ST

Legende
Legend

734



Scan
QR-Code

Oder besuchen Sie // Or Visit
www.simtek.info/cp/933

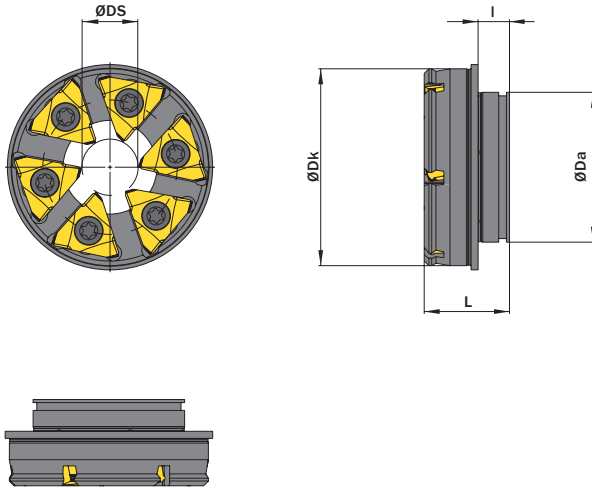


Abbildung zeigt / Drawing shows: CF5.1242.06 W

ØDS mm	Anzahl Plattensitze Number of insert seats	Artikelnummer Part number	Webcode www.simtek.com/webcode	ØDa mm	ØDk mm	I mm	L mm	Aggregat Whirling units	Schraube Screw	Schraubenschlüssel Screw driver	Connectcode www.simtek.com/code
11,4	6	CF5.1242.06 W	AQAW	31,97	42,0	6,7	18,2	TN762004	FM4x8,5T15F	T15F	CF5.L.4.1
20,0	8	CF5.WW54.20.08	A1F9	56,5	54,0	1,5	13,8	TN762006	FM4x8,5T15F	T15F	CF5.L.4.1

Bestellbeispiel // Order example: **CF5.1242.06 W**

Gewindewirbelkopf „Citizen“

Für Citizen-Maschinen mit Citizen-Aggregat.

Thread Whirling Head „Citizen“

For Citizen machines with Citizen whirling unit.

Anzugsmoment (Schraube) // Tightening torque (screw)

4,5 Nm



TW
ST

Legende
Legend

734



Scan
QR-Code

Oder besuchen Sie // Or Visit
www.simtek.info/cp/1223

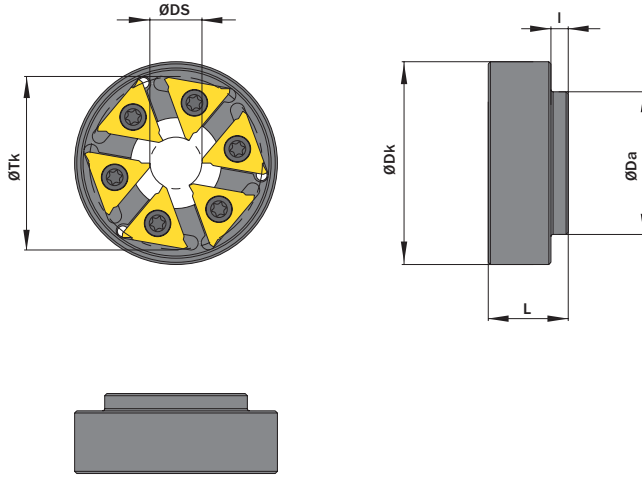


Abbildung zeigt / Drawing shows: CF5.CC33.12.06

ØDS	Anzahl Plattensitze Number of insert seats	Artikelnummer Part number	Webcode www.simtek.com/webcode	ØDa	ØDk	I	L	ØTk	Aggregat Whirling units	Schraube Screw	Schraubenschlüssel Screw driver	Connectcode www.simtek.com/code
mm				mm	mm	mm	mm	mm				
12,0	6	CF5.CC33.12.06	AZU1	33,0	46,9	4,0	18,5	40,0	BTW 1000	FM4x8,5T15F	T15F	CF5.L.4.1

Bestellbeispiel // Order example: **CF5.CC33.12.06**

Gewindewirbelkopf „Citizen“

Für Citizen-Maschinen.

Thread Whirling Head „Citizen“

For Citizen machines.

Anzugsmoment (Schraube) // Tightening torque (screw)

4,5 Nm



TW Legende
ST Legend

734

Scan QR-Code Oder besuchen Sie // Or Visit www.simtek.info/cp/926

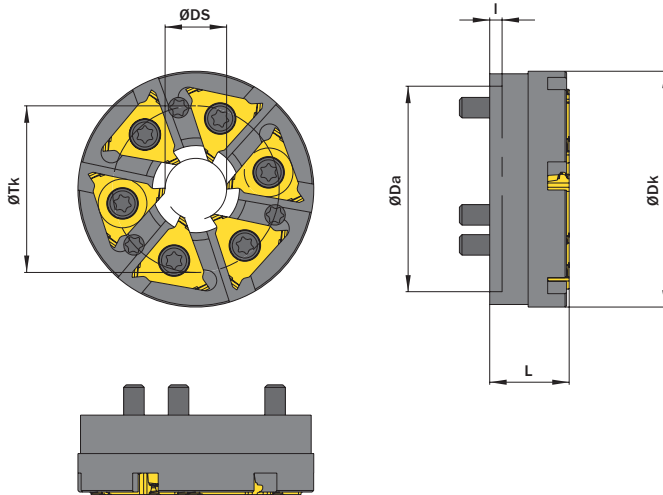


Abbildung zeigt / Drawing shows: CF5.CP40.12.06

ØDS	Anzahl Plattensitze Number of insert seats	Artikelnummer Part number	Webcode www.simtek.com/webcode	ØDa	ØDk	I	L	ØTk	Aggregat Whirling units	Schraube Screw	Schraubenschlüssel Screw driver	Connectcode www.simtek.com/code
mm				mm	mm	mm	mm	mm				
6,0	6	CF5.CP20.06.06	A106	20,0	35,0	3,2	15,0	26,0	GSW 101	NM4x8,5 T15F	T15F	CF5.L.4.1
12,0	6	CF5.CP40.12.06	AS3Y	40,0	46,0	2,5	15,5	32,5	MWS 101; KSW 101; LSW 101; LSW 215315; BSW 215	NM4x8,5 T15F	T15F	CF5.L.4.1
12,0	6	CF5.CP45.12.06	A105	45,0	46,0	9,5	18,0	30,0	LSW-424	NM4x8,5 T15F	T15F	CF5.L.4.1

Bestellbeispiel // Order example: **CF5.CP40.12.06**

Befestigungsschraube // Fastening screw: D M4x12 T15F

Gewindewirbelkopf „Star“

Für Star-Maschinen.

Thread Whirling Head „Star“

For Star machines.

Anzugsmoment (Schraube) // Tightening torque (screw)

4,5 Nm



Legende
Legend **734**



Scan
QR-Code

Oder besuchen Sie // Or Visit
www.simtek.info/cp/925

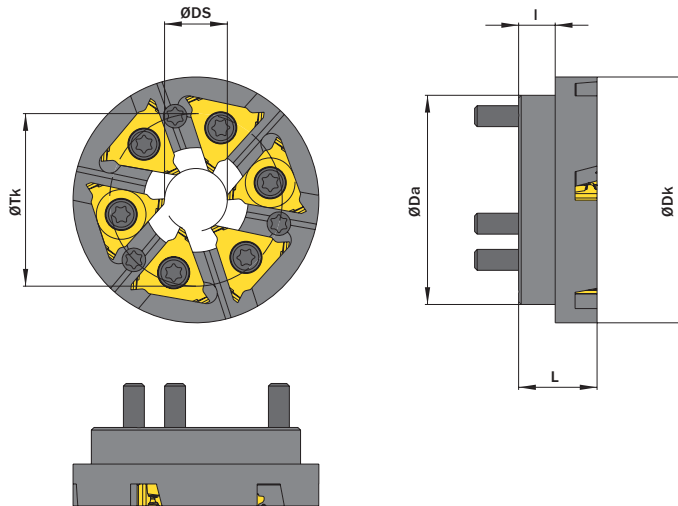


Abbildung zeigt / Drawing shows: CF5.DD40.12.06

ØDS	Anzahl Plattensitze Number of insert seats	Artikelnummer Part number	Webcode www.simtek.com/webcode	ØDa	ØDk	I	L	ØTk	Aggregat Whirling units	Schraube Screw	Schraubenschlüssel Screw driver	Connectcode www.simtek.com/code
mm				mm	mm	mm	mm	mm				
12,0	6	CF5.DD40.12.06	AS30	40,0	47,0	7,0	15,0	33,0	5914 72 00 / 68172	N M4x8,5 T15F	T15F	CF5.L.4.1

Bestellbeispiel // Order example: **CF5.DD40.12.06**

Befestigungsschraube // Fastening screw: D M4x12 T15F

Gewindewirbelkopf „Tsugami“

Für Tsugami-Maschinen.

Thread Whirling Head „Tsugami“

For Tsugami machines.

Anzugsmoment (Schraube) // Tightening torque (screw)

“F M4x11 T15F”: 4,5 Nm
“F M4x8,5 T15F”: 4,5 Nm



Legende
Legend **734**



Scan
QR-Code

Oder besuchen Sie // Or Visit
www.simtek.info/cp/928

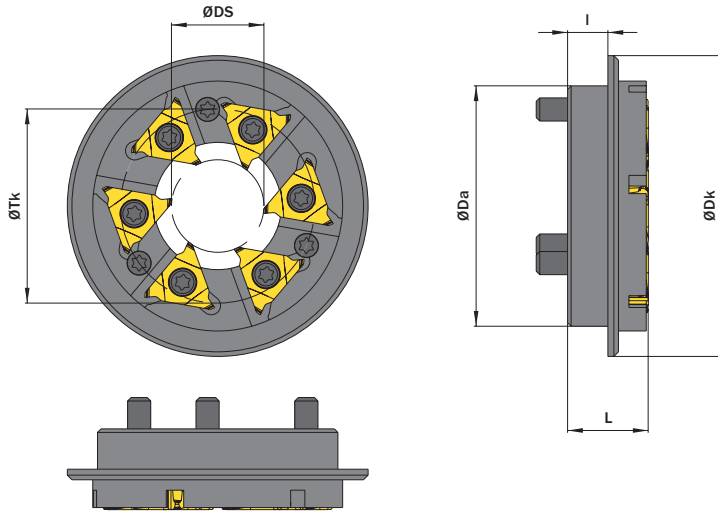


Abbildung zeigt / Drawing shows: CF5.BB52.20.06

ØDa	ØDS	Anzahl Plattensitze Number of insert seats	Artikelnummer Part number	Webcode www.simtek.com/webcode	ØDk	I	L	ØTk	Aggregat Whirling units	Schraube Screw	Schraubenschlüssel Screw driver	Connectcode www.simtek.com/code
50,0	16,0	6	CF5.BB50.16.06	A1ZF	62,0	8,5	20,0	40,0	3214 Y342	FM4x8,5T15F	T15F	CF5.L.4.1
52,0	12,0	6	CF5.BB52.12.06	AXXQ	65,0	8,7	17,0	42,0	3234 Y342	FM4x11 T15F	T15F	CF5.L.4.1
52,0	12,0	6	CF5.BB52.12.10.06	A103	52,0	10,0	10,0	44,0	3268 Y452	FM4x8,5T15F	T15F	CF5.L.4.1
52,0	12,0	6	CF5.BB52.12.19.06	A1QM	54,0	6,0	19,0	38,0	3268 Y271	FM4x8,5T15F	T15F	CF5.L.4.1
52,0	20,0	6	CF5.BB52.20.06	AS31	65,0	8,7	17,0	42,0	3234 Y342	FM4x11 T15F	T15F	CF5.L.4.1

Bestellbeispiel // Order example: **CF5.BB52.12.06**

Befestigungsschraube // Fastening screw: D M5x13 T20R

Gewindewirbelkopf „Hanwaha“

Für Hanwaha-Maschinen mit Madaula-Aggregat.

Thread Whirling Head „Hanwaha“

For Hanwaha machines with Madaula unit.

Anzugsmoment (Schraube) // Tightening torque (screw)

4,5 Nm



Legende
Legend

734



Scan
QR-Code

Oder besuchen Sie // Or Visit
www.simtek.info/cp/1176

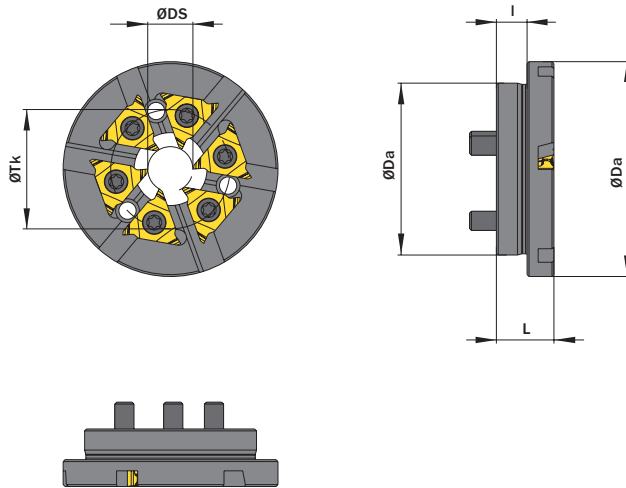


Abbildung zeigt / Drawing shows: CF5.FM45.12.06

ØDS	Anzahl Plattensitze Number of insert seats	Artikelnummer Part number	Webcode www.simtek.com/webcode	ØDa	ØDk	I	L	ØTk	Schraube Screw	Schraubenschlüssel Screw driver	Connectcode www.simtek.com/code
mm				mm	mm	mm	mm	mm			
12,0	6	CF5.FM45.12.06	AZCQ	45,0	56,0	8,5	15,0	31,2	FM4x8,5 T15F	T15F	CF5.L.4.1

Bestellbeispiel // Order example: **CF5.FM45.12.06**

Befestigungsschraube // Fastening screw: D M4x12 T15F

Gewindewirbelplatten


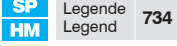

Gewindewirbelplatten für HA-Gewinde.

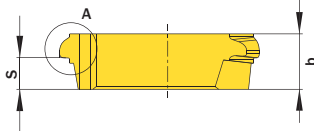
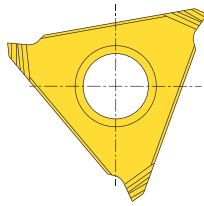
Thread Whirling inserts

Thread whirling inserts for HA-threads.

Schnittwerte (Start) // Cutting parameters (start) **Vc**
Seite/Page 696

Passende Klemmhalter auf Seite // Suitable toolholders on page
699, 700, 701, 702, 703, 704, 705



 Legende Legend **734**
 Scan QR-Code Oder besuchen Sie // Or Visit www.simtek.info/cp/916



Detail A (20 : 1)

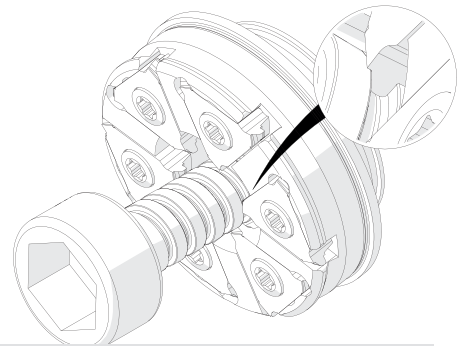
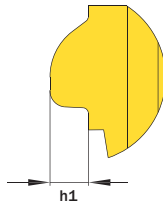


Illustration zeigt beispielhafte Anwendungsmöglichkeit mit ähnlichem Werkzeug.
Image shows exemplary application possibility with similar tool.

Abbildung zeigt / Drawing shows: CF5.175.HA.02 M

Steigung (von) Pitch (as of)	Artikelnummer Part number	Webcode www.simtek.com/webcode	Schneidstoffgruppe Cutting Grade Group	b	h1	S	Connectcode www.simtek.com/ccode
				mm	mm	mm	
0,5	CF5.050.HA.02 M	AUK5	CH G F K	4,1	0,19	3,5	CF5.L.4.1
0,6	CF5.060.HA.02 M	AUK6	CH G F K	4,1	0,34	3,5	CF5.L.4.1
1,0	CF5.100.HA.02 M	AUK7	CH G F K	4,1	0,4	3,1	CF5.L.4.1
1,25	CF5.125.HA.02 M	AUK8	CH G F K	4,1	0,55	2,8	CF5.L.4.1
1,5	CF5.150.HA.02 M	AS3P	CH G F K	4,1	0,55	2,5	CF5.L.4.1
1,75	CF5.175.HA.02 M	AS3Q	CH G F K	4,1	0,75	2,3	CF5.L.4.1

Bestellbeispiel // Order example: **CF5.100.HA.02 M X800** (X800 = Schneidstoff // Grade)

Gewindewirbelplatte


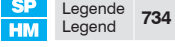
Gewindewirbelplatten für HB-Gewinde.

Thread Whirling inserts

Thread whirling inserts for HB-threads.

Schnittwerte (Start) // Cutting parameters (start) **Vc**
Seite/Page 696

Passende Klemmhalter auf Seite // Suitable toolholders on page
699, 700, 701, 702, 703, 704, 705

 Scan QR-Code Oder besuchen Sie // Or Visit www.simtek.info/cp/919

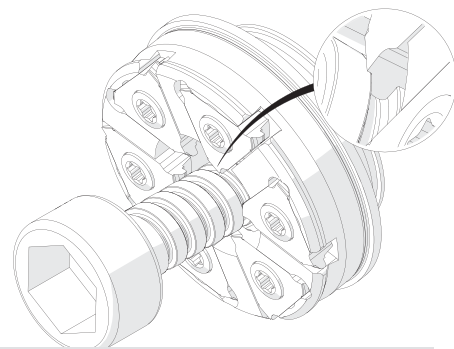
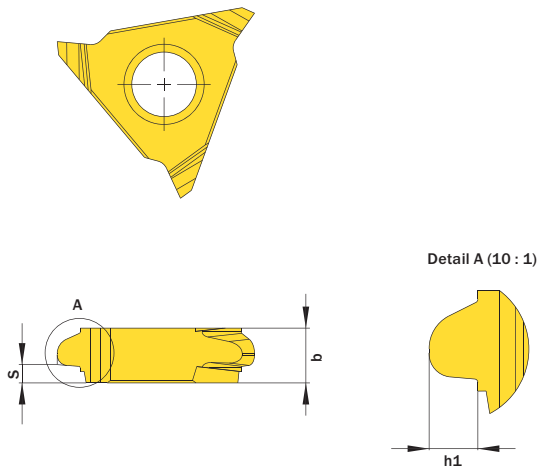


Illustration zeigt beispielhafte Anwendungsmöglichkeit mit ähnlichem Werkzeug.
Image shows exemplary application possibility with similar tool.

Abbildung zeigt / Drawing shows: CF5.275.HB.02 M

Steigung (von) Pitch (as of)	Artikelnummer Part number	Webcode www.simtek.com/webcode	Schneidstoffgruppe Cutting Grade Group	b	h1	s	Connectcode www.simtek.com/ccode
				mm	mm	mm	
1,75	CF5.175.HB.02 M	AS3S	CHGFK	4,1	1,05	2,35	CF5.L.4.1
2,75	CF5.275.HB.02 M	AS3T	CHGFK	4,1	1,75	1,4	CF5.L.4.1

Bestellbeispiel // Order example: **CF5.175.HB.02 M X800** (X800 = Schneidstoff // Grade)

Gewindewirbelplatten, metr. ISO

Gewindewirbelplatten für metrische ISO-Gewinde, Vollprofil. Für Gewinde der Toleranzklasse 6H/6g.

Thread Whirling Inserts, metr. ISO

Thread whirling inserts for metric ISO-threads, full profile. For threads with tolerance class 6H/6g.

Schnittwerte (Start) Vc
Cutting parameters (start) **Seite/Page 696**

Passende Klemmhalter auf Seite // Suitable toolholders on page
699, 700, 701, 702, 703, 704, 705

Bitte Hinweise im Anhang beachten // Please read add. notes

Wichtige Hinweise // Important hints (Seite/Page 733)



SP Legende
HM Legend **734**

Scan QR-Code Oder besuchen Sie // Or Visit
www.simtek.info/cp/1328

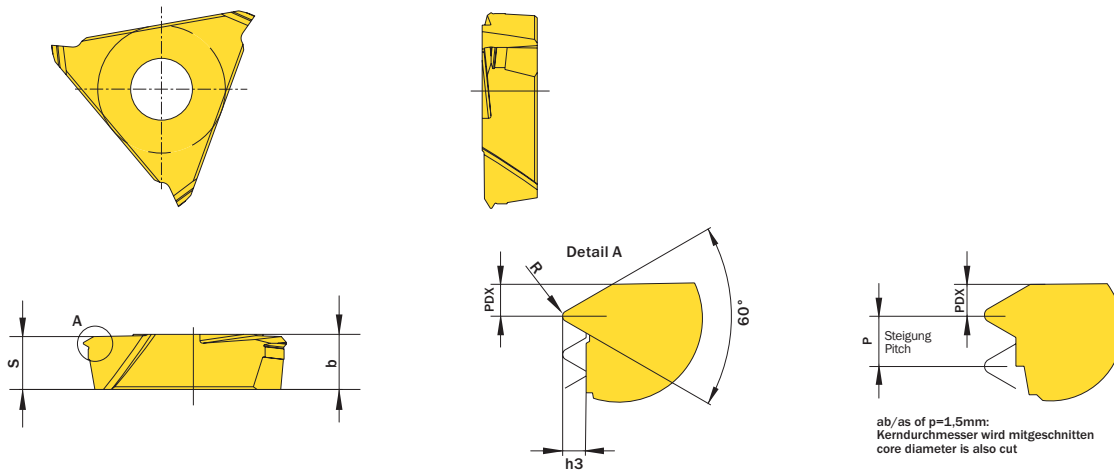


Abbildung zeigt / Drawing shows: CF5.060.MT.02 M

h3	Steigung (von Pitch (as of)	Artikelnummer Part number	Webcode www.simtek.com/webcode	Schneidstoffgruppe Cutting Grade Group	b	R	S	PDX	Connectcode www.simtek.com/code	
mm	mm				mm	mm	mm	mm		
0,31	0,5	CF5.050.MT.02 M	A28M	CHGFK	4,1	0,06	3,94	0,45	CF5.L.4.1	new
0,37	0,6	CF5.060.MT.02 M	A28N	CHGFK	4,1	0,08	3,94	0,5	CF5.L.4.1	new
0,43	0,7	CF5.070.MT.02 M	A28P	CHGFK	4,1	0,09	3,93	0,55	CF5.L.4.1	new
0,49	0,8	CF5.080.MT.02 M	A28Q	CHGFK	4,1	0,1	3,93	0,6	CF5.L.4.1	new
0,61	1,0	CF5.100.MT.02 M	A28S	CHGFK	4,1	0,12	3,94	0,65	CF5.L.4.1	new
0,77	1,25	CF5.125.MT.02 M	A5EN	CHGFK	4,1	0,16	3,94	0,77	CF5.L.4.1	new
0,92	1,5	CF5.150.MT.02 M	A5EQ	CHGFK	4,1	0,19	3,94	0,9	CF5.L.4.1	new

Bestellbeispiel // Order example: **CF5.100.MT.02 M HX79** (HX79 = Schneidstoff // Grade)

Halbzeuge

CF5-Halbzeuge für komponenten- und kundenspezifische Formen.

Semi-Finished Inserts

Semi-finished-insert for component- and customer-specific forms.

Schnittwerte (Start) // Cutting parameters (start) Vc
Seite/Page 696

Passende Klemmhalter auf Seite // Suitable toolholders on page
699, 700, 701, 702, 703, 704, 705

	SP	Legende	734
	HM	Legende	
		Scan QR-Code	Oder besuchen Sie // Or Visit www.simtek.info/cp/932

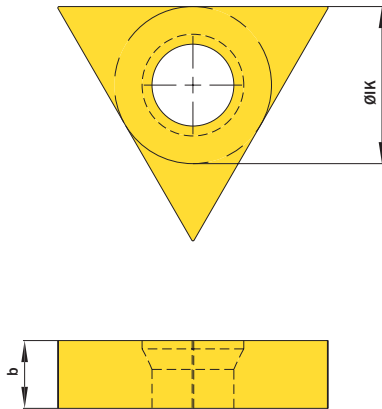


Abbildung zeigt / Drawing shows: CF5.0410.00 M

b	Artikelnummer Part number	Webcode www.simtek.com/webcode	Schneidstoffgruppe Cutting Grade Group	ØIK	Connectcode www.simtek.com/ccode
mm				mm	
4,1	CF5.0410.00 M	AS1N	CH G F K	9,5	CF5.L.4.1
5,5	CF5.0550.00 M	AS1P	CH G F K	9,5	CF5.L.4.1

Bestellbeispiel // Order example: **CF5.0550.00 M GF25** (GF25 = Schneidstoff // Grade)

Das Werkzeugsystem simcut K2 The Tool System simcut K2

Gewindewirbelwerkzeuge für die Medizintechnik und für schwer spanbare Materialien.
Thread Whirling applications in medical technology an in difficult-to-machine materials.



Werkzeuggruppe aus hochpräzisen, zweiseitigen Hartmetall-Wendeschneidplatten mit ausgesuchten Beschichtungen und präzisen Wirbelringen. Besonders geeignet auch für schwer spanbare Materialien.

Durch seine Bauart bedingt, bietet das System gegenüber dreiseitigen Wendeplattensystemen rund 50% mehr Schneiden bei gleichem Kerndurchmesser.

Tool system of high precision, two-edged carbide inserts with special coatings and matching whirling ring. Suitable for „difficult-to-machine materials“ too.

Due to its two-edged design, this system provides up to 50% more cutting edges in equal diameters compared to three-edged systems.

Gewindewirbelkopf „Tornos“

Für Tornos-Maschinen.

Thread Whirling Head „Tornos“

For Tornos machines.

Anzugsmoment (Schraube) // Tightening torque (screw)

3,0 Nm



TW
ST

Legende
Legend

734



Scan
QR-Code

Oder besuchen Sie // Or Visit
www.simtek.info/cp/1089

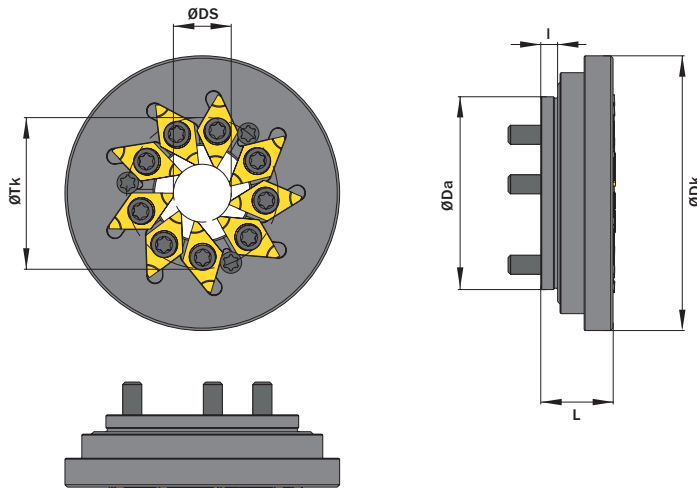


Abbildung zeigt / Drawing shows: CK2.A.AA40.12.09

ØDS	Anzahl Plattensitze Number of insert seats	Artikelnummer Part number	Webcode www.simtek.com/webcode	ØDa	ØDk	I	L	ØTk	Aggregat Whirling units	Schraube Screw	Schraubenschlüssel Screw driver	Connectcode www.simtek.com/code
mm				mm	mm	mm	mm	mm				
12,0	9	CK2.A.AA40.12.09	AXYA	40,0	57,0	3,5	15,0	31,0	306101/307087	M M3,5x9 T10F	T10F	CK2.L.4.0
12,0	9	CK2.A.AA50.12.09	AZU9	50,0	64,0	3,5	15,1	40,0	417627	M M3,5x9 T10F	T10F	CK2.L.4.0

Bestellbeispiel // Order example: **CK2.A.AA50.12.09**

Um Spanprobleme auf Grund des geringen Schneidkreises zu vermeiden, empfehlen wir bei diesem Werkzeug mit einem hohen Kühlmitteldruck zu arbeiten.
In order to prevent chip problems due to the small cutting diameter, we recommend to use these tools together with a high coolant pressure.

Befestigungsschraube: D M4x12 T15F
Fastening screw: D M4x12 T15F

Gewindewirbelkopf „WTO“

Für WTO-Aggregat.

Thread Whirling Head „WTO“

For WTO whirling units.

Anzugsmoment (Schraube) // Tightening torque (screw)

3,0 Nm



Legende
Legend **734**



Scan
QR-Code

Oder besuchen Sie // Or Visit
www.simtek.info/cp/1090

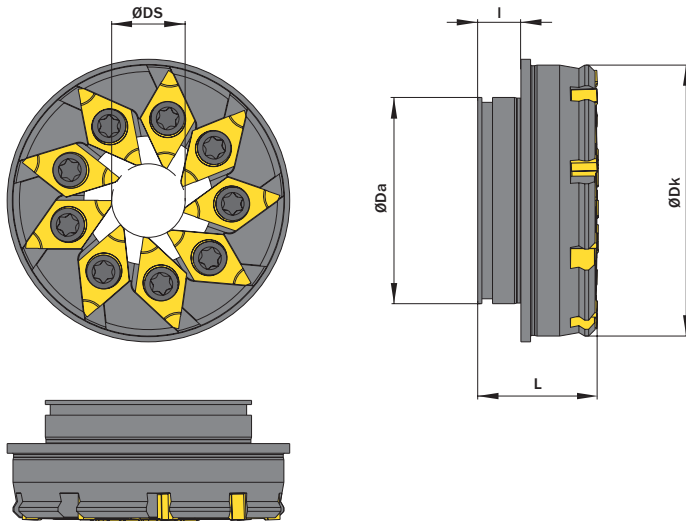


Abbildung zeigt / Drawing shows: CK2.A.1242.09 W

ØDS	Anzahl Plattensitze Number of insert seats	Artikelnummer Part number	Webcode www.simtek.com/webcode	ØDa	ØDk	I	L	Aggregat Whirling units	Schraube Screw	Schraubenschlüssel Screw driver	Connectcode www.simtek.com/code
mm				mm	mm	mm	mm				
11,4	9	CK2.A.1242.09 W	AXYB	32,0	42,0	6,7	18,7	TN762004	MM3,5xT10F	T10F	CK2.L.4.0

Bestellbeispiel // Order example: **CK2.A.1242.09 W**

Um Spanproblem auf Grund des geringen Schneidkreises zu vermeiden, empfehlen wir bei diesem Werkzeug mit einem hohen Kühlmitteldruck zu arbeiten.
In order to prevent chip problems due to the small cutting diameter, we recommend to use these tools together with a high coolant pressure.

Gewindewirbelkopf „Citizen“

Für Citizen-Maschinen.

Thread Whirling Head „Citizen“

For Citizen machines.

Anzugsmoment (Schraube) // Tightening torque (screw)

3,0 Nm



TW
ST

Legende
Legend

734



Scan
QR-Code

Oder besuchen Sie // Or Visit
www.simtek.info/cp/1091

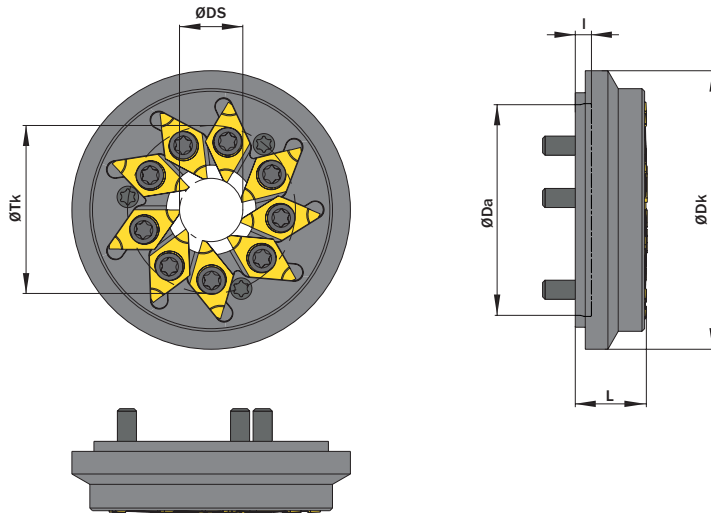


Abbildung zeigt / Drawing shows: CK2.A.CJ40.12.09

ØDS	Anzahl Plattensitze Number of insert seats	Artikelnummer Part number	Webcode www.simtek.com/webcode	ØDa	ØDk	I	L	ØTk	Aggregat Whirling units	Schraube Screw	Schraubenschlüssel Screw driver	Connectcode www.simtek.com/code
mm				mm	mm	mm	mm	mm				
12,0	9	CK2.A.CJ40.12.09	AXYC	40,0	52,8	3,0	13,65	32,0	LTR 0128; 0132; 0139	M M3,5x9 T10F	T10F	CK2.L.4.0

Bestellbeispiel // Order example: **CK2.A.CJ40.12.09**

Um Spanproblem auf Grund des geringen Schneidkreises zu vermeiden, empfehlen wir bei diesem Werkzeug mit einem hohen Kühlmitteldruck zu arbeiten.
In order to prevent chip problems due to the small cutting diameter, we recommend to use these tools together with a high coolant pressure.

Befestigungsschraube: D M4x12 T15F
Fastening screw: D M4x12 T15F

Gewindewirbelkopf „Citizen“

Für Citizen-Maschinen.

Thread Whirling Head „Citizen“

For Citizen machines.

Anzugsmoment (Schraube) // Tightening torque (screw)

3,0 Nm



TW
ST

Legende
Legend

734



Scan
QR-Code

Oder besuchen Sie // Or Visit
www.simtek.info/cp/1092

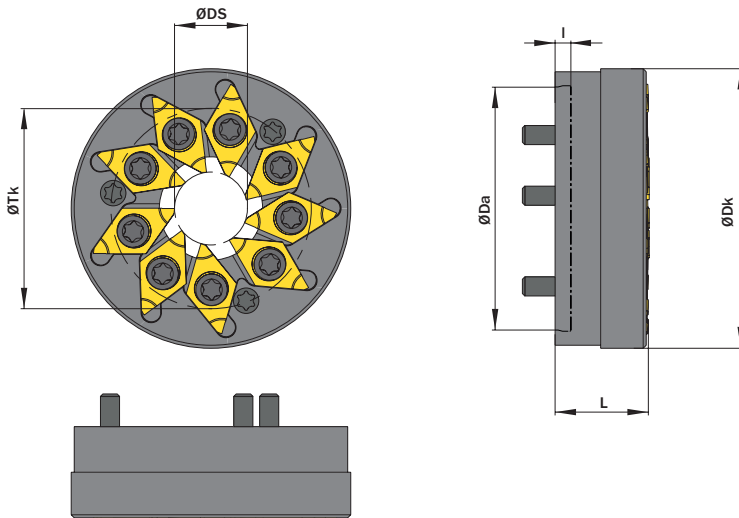


Abbildung zeigt / Drawing shows: CK2.A.CP40.12.09

ØDS	Anzahl Plattensitze Number of insert seats	Artikelnummer Part number	Webcode www.simtek.com/webcode	ØDa	ØDk	I	L	ØTk	Aggregat Whirling units	Schraube Screw	Schraubenschlüssel Screw driver	Connectcode www.simtek.com/ccode
mm				mm	mm	mm	mm	mm				
12,0	9	CK2.A.CP40.12.09	AXYD	40,0	46,0	2,5	15,5	32,5	MWS 101; KSW 101; LSW 101; LSW 215315; BSW 215	M3,5x9 T10F	T10F	CK2.L.4.0

Bestellbeispiel // Order example: **CK2.A.CP40.12.09**

Um Spanproblem auf Grund des geringen Schneidkreises zu vermeiden, empfehlen wir bei diesem Werkzeug mit einem hohen Kühlmitteldruck zu arbeiten.
In order to prevent chip problems due to the small cutting diameter, we recommend to use these tools together with a high coolant pressure.

Befestigungsschraube: D M4x12 T15F
Fastening screw: D M4x12 T15F

Gewindewirbelkopf „Star“

Für Star-Maschinen.

Thread Whirling Head „Star“

For Star machines.

Anzugsmoment (Schraube) // Tightening torque (screw)

3,0 Nm



TW
ST

Legende
Legend

734



Scan
QR-Code

Oder besuchen Sie // Or Visit
www.simtek.info/cp/1093

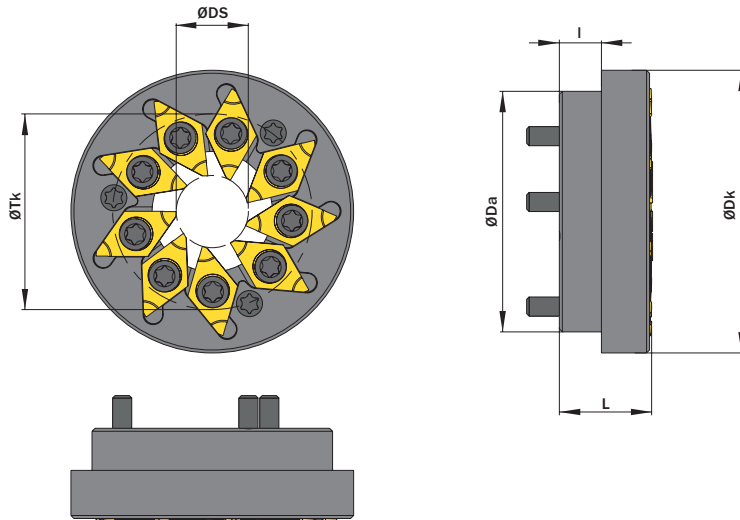


Abbildung zeigt / Drawing shows: CK2.A.DD40.12.09

ØDS	Anzahl Plattensitze Number of insert seats	Artikelnummer Part number	Webcode www.simtek.com/webcode	ØDa	ØDk	I	L	ØTk	Aggregat Whirling units	Schraube Screw	Schraubenschlüssel Screw driver	Connectcode www.simtek.com/code
mm				mm	mm	mm	mm	mm				
12,0	9	CK2.A.DD40.12.09	AXYE	40,0	47,0	7,0	15,5	33,0	5914 72 00 / 68172	M M3,5x9 T10F	T10F	CK2.L.4.0

Bestellbeispiel // Order example: **CK2.A.DD40.12.09**

Um Spanproblem auf Grund des geringen Schneidkreises zu vermeiden, empfehlen wir bei diesem Werkzeug mit einem hohen Kühlmitteldruck zu arbeiten.
In order to prevent chip problems due to the small cutting diameter, we recommend to use these tools together with a high coolant pressure.

Befestigungsschraube: D M4x12 T15F
Fastening screw: D M4x12 T15F

Gewindewirbelkopf „Tsugami“

Für Tsugami-Maschinen.

Thread Whirling Head „Tsugami“

For Tsugami machines.

Anzugsmoment (Schraube) // Tightening torque (screw)

3,0 Nm



Legende
Legend **734**



Scan
QR-Code

Oder besuchen Sie // Or Visit
www.simtek.info/cp/1094

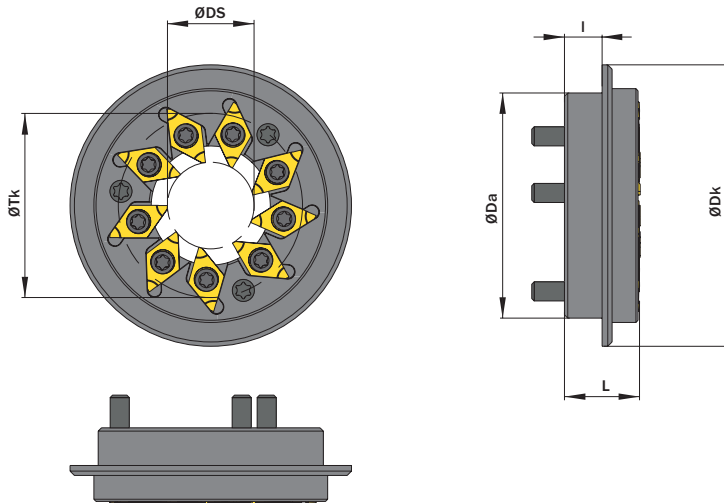


Abbildung zeigt / Drawing shows: CK2.A.BB52.20.09

ØDS	Anzahl Plattensitze Number of insert seats	Artikelnummer Part number	Webcode www.simtek.com/webcode	ØDa	ØDk	I	L	ØTk	Schraube Screw	Schraubenschlüssel Screw driver	Connectcode www.simtek.com/ccode
mm				mm	mm	mm	mm	mm			
12,0	9	CK2.A.BB52.12.09	AXYF	52,0	65,0	8,7	17,5	42,0	MM3,5xT10F	T10F	CK2.L.4.0
20,0	9	CK2.A.BB52.20.09	AXYG	52,0	65,0	8,7	17,5	42,0	MM3,5xT10F	T10F	CK2.L.4.0

Bestellbeispiel // Order example: **CK2.A.BB52.20.09**

Um Spanproblem auf Grund des geringen Schneidkreises zu vermeiden, empfehlen wir bei diesem Werkzeug mit einem hohen Kühlmitteldruck zu arbeiten.
In order to prevent chip problems due to the small cutting diameter, we recommend to use these tools together with a high coolant pressure.

Befestigungsschraube: D M5x13 T20R
Fastening screw: D M5x13 T20R

Gewindewirbelkopf

Für Citizen-Maschinen.

Thread Whirling Head

For Citizen machines.

Anzugsmoment (Schraube) // Tightening torque (screw)

3,0 Nm



TW
ST

Legende
Legend **734**



Scan
QR-Code

Oder besuchen Sie // Or Visit
www.simtek.info/cp/1237

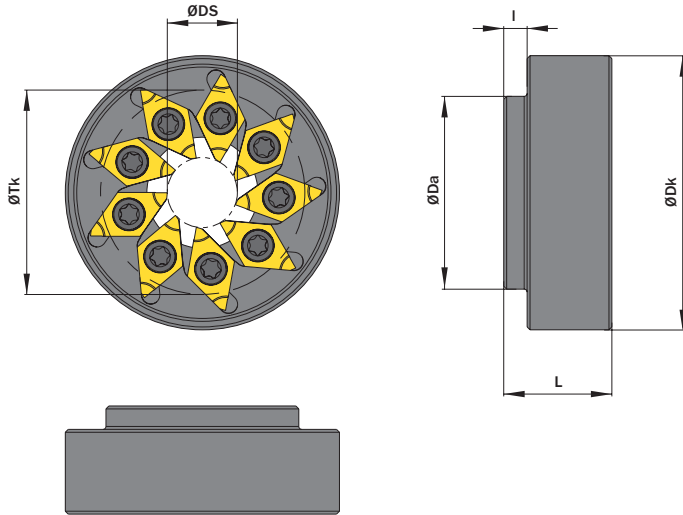


Abbildung zeigt / Drawing shows: CK2.A.CC33.12.09

ØDS	Anzahl Plattensitze Number of insert seats	Artikelnummer Part number	Webcode www.simtek.com/webcode	ØDa	ØDk	I	L	ØTk	Aggregat Whirling units	Schraube Screw	Schraubenschlüssel Screw driver	Connectcode www.simtek.com/code
mm				mm	mm	mm	mm	mm				
12,0	9	CK2.A.CC33.12.09	AZVA	43,0	46,9	4,75	18,5	40,0	BTW 1000	M M3,5x9 T10F	T10F	CK2.L.4.0

Bestellbeispiel // Order example: **CK2.A.CC33.12.09**

Um Spanproblem auf Grund des geringen Schneidkreises zu vermeiden, empfehlen wir bei diesem Werkzeug mit einem hohen Kühlmitteldruck zu arbeiten.
In order to prevent chip problems due to the small cutting diameter, we recommend to use these tools together with a high coolant pressure.

Halbzeuge

Halbzeuge für komponenten- und kundenspezifische Formen.

Semi-Finished Inserts

Semi-finished-insert for component- and customer-specific forms.

Schnittwerte (Start) // Cutting parameters (start) Vc
Seite/Page 696

Passende Klemmhalter auf Seite // Suitable toolholders on page
711, 712, 713, 714, 715, 716, 717

SP

Legende

HM

Legende

734

Scan QR-Code

Oder besuchen Sie // Or Visit www.simtek.info/cp/1095

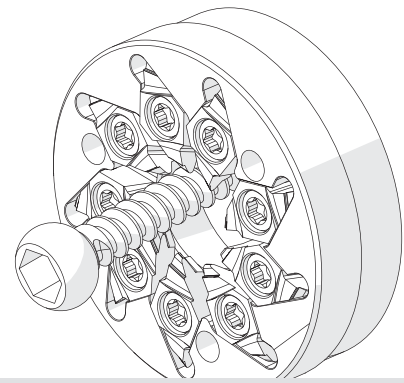
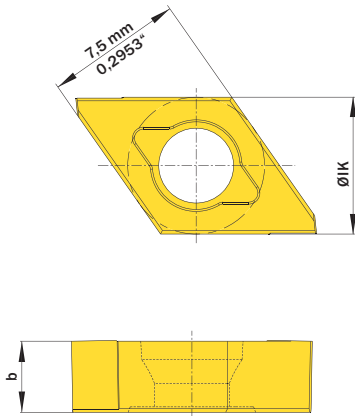


Illustration zeigt beispielhafte Anwendungsmöglichkeit mit ähnlichem Werkzeug.
Image shows exemplary application possibility with similar tool.

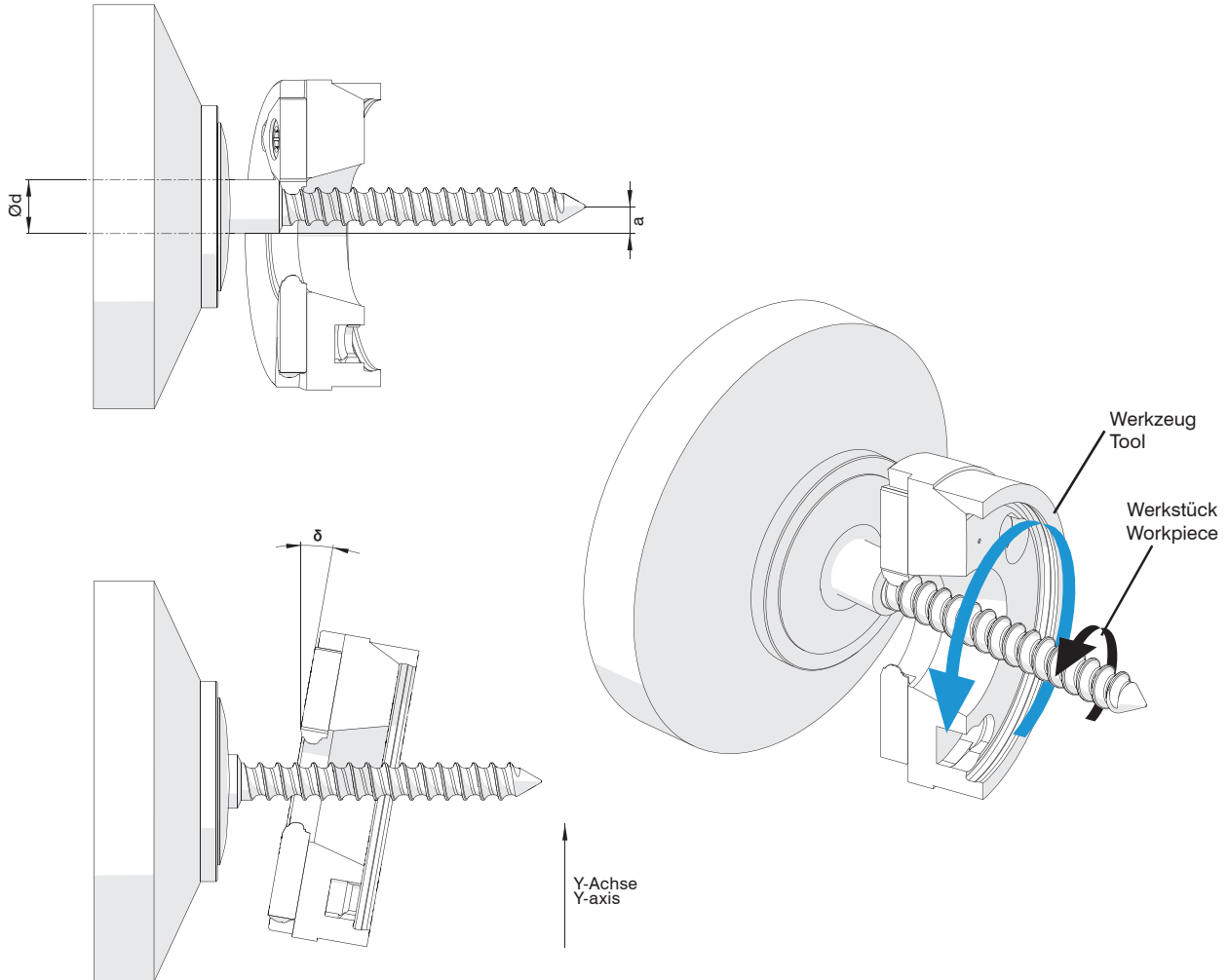
Abbildung zeigt / Drawing shows: CK2.A.0390.00 M

b	Artikelnummer Part number	Webcode www.simtek.com/webcode	Schneidstoffgruppe Cutting Grade Group	ØIK	Connectcode www.simtek.com/ccode
mm				mm	
3,9	CK2.A.0390.00 M	AXYJ	CH G FK	7,5	CK2.L.4.0
6,3	CK2.A.0630.00 M	AXYK	CH G FK	7,5	CK2.L.4.0

Bestellbeispiel // Order example: **CK2.A.0390.00 M GF25** (GF25 = Schneidstoff // Grade)

Info

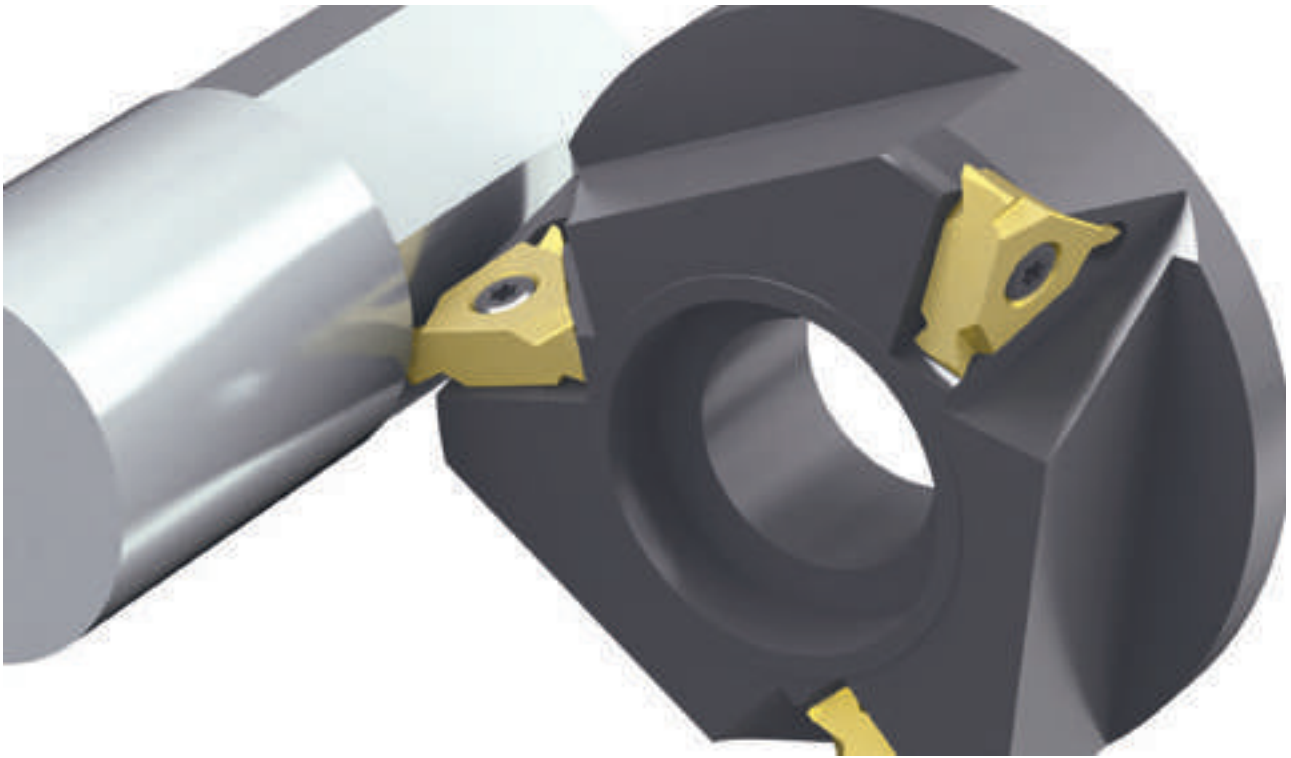
Schnittwertberechnung für das Gewindewirbeln Cutting data calculation for the thread whirling



Anzahl der Schneiden // Numbers of cutting edges	6 oder 9 // 6 or 9
Schnittgeschwindigkeitsbereich // Range of cutting speed	40 - 60 m // min
Vorschubsbereich // Feed range	0,02-0,10 mm / Schneide // Cutting edge
Schwenkwinkel der Antriebseinheit // Unit swivel angle	Siehe Hersteller // Refer to unit manufacturer

Das Werkzeugsystem simcut MX The Tool System simcut MX

Mehrkantfräsen im Längs- oder Stechdrehverfahren.
High performance Polygon Milling Tools.



Werkzeugsystem aus drei- oder sechsschneidigen Hartmetall-Wendeschneidplatten und Scheibenfräsern mit mehreren Plattensitzen für das Mehrkantfräsen im Längs- oder Stechdrehverfahren.

Durch die Variation der Schneidenzahl und des Übersetzungsverhältnisses können mit demselben Scheibenfräser verschiedene Mehrkant-Profile gefräst werden.

Tool system of three or six edged indexable carbide insert and disc milling cutters with several insert seats for longitudinal or radial feed polygon milling.

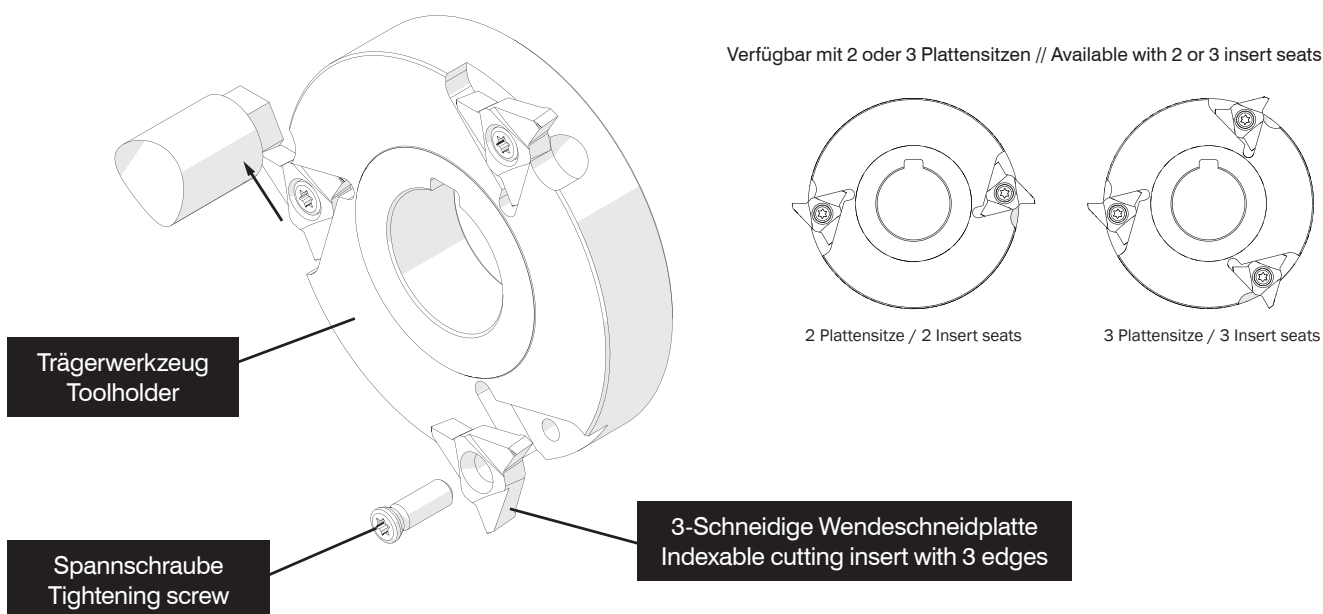
A range of polygon profiles are machinable with one disc milling cutter by variation of used cutting inserts and transmission ratio.

Das System im Detail The System Details

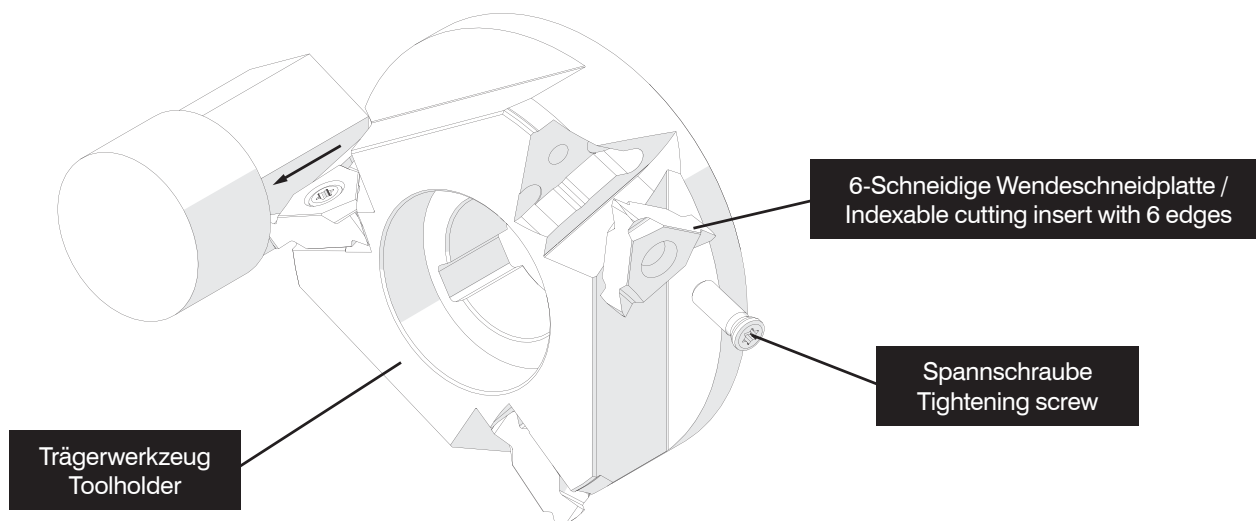
Bitte beachten Sie die allgemeinen Gebrauchshinweise auf Seite
Please read the general instructions for use on page

733

Stechdrehverfahren // Radial feed polygon milling



Längsdrehverfahren // Longitudinal feed polygon milling



Mehrkantfräsen // Polygon Milling

Durch Mehrkantfräsen auf Drehmaschinen lassen sich Schlüsselflächen an rotationssymmetrischen Werkstücken erzeugen. Zum Mehrkantfräsen müssen die Hauptspindel (Werkstück) und die Werkzeugspindel (Mehrkantfräser) in einem fest synchronisierten Übersetzungsverhältnis im Gegenlauf zueinander laufen.

Die Anzahl der erzeugten Flächen wird durch die Zähnezahl des Fräasers (z) und das Übersetzungsverhältnis (i) bestimmt (siehe Tabelle Seite 683).

Da beim Mehrkantfräsen zwei Kreisbewegungen überlagert werden, entstehen je nach Übersetzungsverhältnis konvexe oder konkave Flächen. Dieser Effekt ist aber meist vernachlässigbar und verringert sich mit im Verhältnis größeren Schneidkreisen. Empfehlenswerte Kombinationen für die üblichen 6-Kant-Schlüsselweiten können der nachfolgenden Tabelle entnommen werden, in allen weiteren Fällen ist eine technische Prüfung erforderlich.

Der Vorschub des Fräasers erfolgt in Richtung der Werkstückachse, wobei auch Fasen und Ausläufe kopiert werden können. Wenn Flächen bearbeitet werden sollen, die hinter einem Bund liegen, kann auch radial eingestochen werden.

Polygon milling allows the machining of flats at rotationally symmetrical work pieces on CNC lathes, Swiss-style lathes and multi spindle machines. For polygon milling, the main spindle (work piece) and the tool spindle (milling cutter) must run at a tightly synchronized transmission ratio in up milling direction.

The number of generated surfaces depends on the number of teeth of the cutter (z) and the transmission ratio (i) (see table on page 683).

The process of polygon milling superimposes two circular movements, this leads to slightly convex or concave surfaces, depending on the transmission ratio. This effect is usually insignificant and can be reduced with proportionally larger cutting diameters. Recommended combinations of cutting diameter and hex wrench sizes are shown in the table below, in all other cases, we recommend a technical assessment.

The feed direction of the cutter should follow the direction of the work piece axis, in doing so additional chamfers and outlets can be copied. Surfaces behind or in between shoulders can also be machined with a radial feed direction.

		Schneidkreis (ØDS) // Cutting diameter (ØDS)										
		27,7 mm	44,0 mm	50,0 mm	63,0 mm	72,0 mm	78,0 mm	80,0 mm	86,0 mm	90,0 mm	98,0 mm	118,0 mm
Schlüsselweite (sw) // Wrench size (sw)	3,2 mm	●	●	●	●	●	●	●	●	●	●	●
	4,0 mm	●	●	●	●	●	●	●	●	●	●	●
	5,0 mm	●	●	●	●	●	●	●	●	●	●	●
	5,5 mm	●	●	●	●	●	●	●	●	●	●	●
	6,0 mm	●	●	●	●	●	●	●	●	●	●	●
	7,0 mm	●	●	●	●	●	●	●	●	●	●	●
	8,0 mm	●	●	●	●	●	●	●	●	●	●	●
	9,0 mm	●	●	●	●	●	●	●	●	●	●	●
	10,0 mm	●	●	●	●	●	●	●	●	●	●	●
	11,0 mm		●	●	●	●	●	●	●	●	●	●
	12,0 mm		●	●	●	●	●	●	●	●	●	●
	13,0 mm		●	●	●	●	●	●	●	●	●	●
	14,0 mm			●	●	●	●	●	●	●	●	●
	15,0 mm				●	●	●	●	●	●	●	●
	16,0 mm				●	●	●	●	●	●	●	●
	18,0 mm				●	●	●	●	●	●	●	●
	22,0 mm				●	●	●	●	●	●	●	●
	24,0 mm					●	●	●	●	●	●	●
	27,0 mm						●	●	●	●	●	●
	30,0 mm									○	●	●
32,0 mm									○	○	●	
36,0 mm									○	○	○	
41,0 mm											○	
46,0 mm											○	
50,0 mm											○	

- Empfohlene Kombination // Recommended combination
- Bedingt empfohlen // Limited recommended

Mehrkantfräswerkzeug

Passend für Gildemeister- und Tornos-Maschinen.

Polygon Milling Toolholder

Suitable for Gildemeister- and Tornos-machines.

Anzugsmoment (Schraube) // Tightening torque (screw)

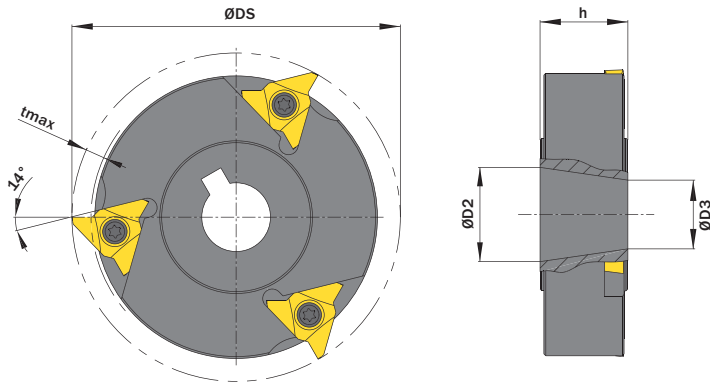
6,0 Nm



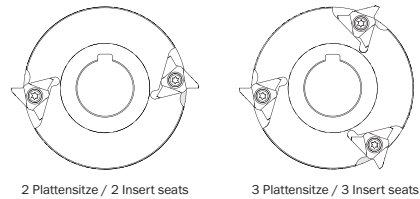
Legende
Legend **734**



Scan
QR-Code Oder besuchen Sie // Or Visit
www.simtek.info/cp/920



Abbildungen ähnlich // Similar illustrations



Für Gildemeister Mehrspindler (GM / GMC) und
Tornos MultiDECO 20/6, 20/8, 20/8b, 26/6, 32/6i
Suitable for Gildemeister Multi-Spindle (GM / GMC) and
Tornos MultiDECO 20/6, 20/8, 20/8b, 26/6, 32/6i

Abbildung zeigt / Drawing shows: CM3.E086.25.03.00 L

ØDS	ØD2	Anzahl Plattsitze Number of insert seats	Artikelnummer Part number	Webcode www.simtek.com/webcode	ØD3	h	tmax	Schraube Screw	Schraubenschlüssel Screw driver	Connectcode www.simtek.com/code
mm	mm				mm	mm	mm			
▼ ØDS = 70,0 mm										
70,0	15,0	2	CM3.E070.25.02.00 L	AXUM	10,64	15,0	5,0	M M5x13 T20R	T20R	CM3.L.6.0
70,0	15,0	3	CM3.E070.25.03.00 L	AXUK	10,64	15,0	5,0	M M5x13 T20R	T20R	CM3.L.6.0
▼ ØDS = 86,0 mm										
86,0	24,69	2	CM3.E086.25.02.00 L	AUMK	18,0	23,0	5,0	M M5x13 T20R	T20R	CM3.L.6.0
86,0	24,69	3	CM3.E086.25.03.00 L	AUMW	18,0	23,0	5,0	M M5x13 T20R	T20R	CM3.L.6.0
▼ ØDS = 98,0 mm										
98,0	26,0	2	CM3.E098.26.02.00 L	AUMN	20,0	23,0	5,0	M M5x13 T20R	T20R	CM3.L.6.0
98,0	26,0	3	CM3.E098.26.03.00 L	AUMY	20,0	23,0	5,0	M M5x13 T20R	T20R	CM3.L.6.0

Bestellbeispiel // Order example: **CM3.E070.25.03.00 L** (L = Linke Ausführung // Left hand version)

Mehrkantfräswerkzeug

Passend für Index-Maschinen.

Polygon Milling Toolholder

Suitable for Index-machines.

Anzugsmoment (Schraube) // Tightening torque (screw)

6,0 Nm

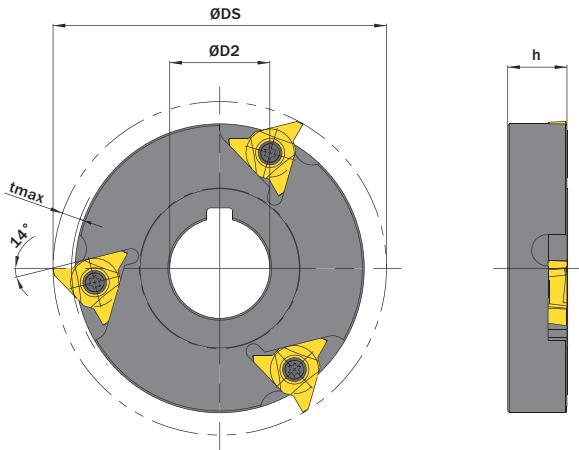


Legende
Legend **734**

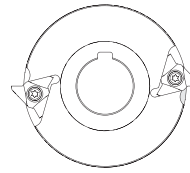


Scan
QR-Code

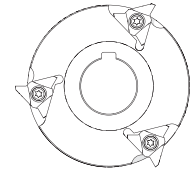
Oder besuchen Sie // Or Visit
www.simtek.info/cp/922



Abbildungen ähnlich // Similar illustrations



2 Plattensitze / 2 Insert seats



3 Plattensitze / 3 Insert seats

Abbildung zeigt / Drawing shows: CM3.X090.27.03.00 L

ØDS	ØD2	Anzahl Plattensitze Number of insert seats	Artikelnummer Part number	Webcode www.simtek.com/webcode	h	tmax	Schraube Screw	Schraubenschlüssel Screw driver	Connectcode www.simtek.com/ccode
mm	mm				mm	mm			
90,0	27,0	2	CM3.X090.27.02.00 R/L	R AUPD L AUAW	16,2	5,0	MM5x13 T20R	T20R	R CM3.R.6.0 L CM3.L.6.0
90,0	27,0	3	CM3.X090.27.03.00 R/L	R AUPE L AUAV	16,2	5,0	MM5x13 T20R	T20R	R CM3.R.6.0 L CM3.L.6.0

Bestellbeispiel // Order example: **CM3.X090.27.02.00 R** (R = Rechte Ausführung // Right hand version)

Mehrkantfräswerkzeug

Passend für Schütte Maschinen.

Polygon Milling Toolholder

Suitable for Schütte machines.

Anzugsmoment (Schraube) // Tightening torque (screw)

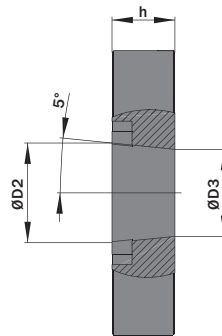
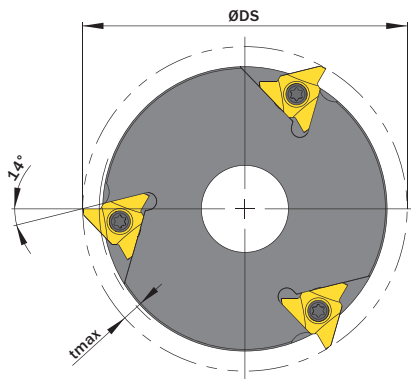
6,0 Nm



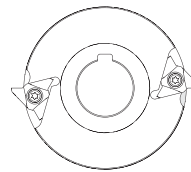
Legende
Legend **734**



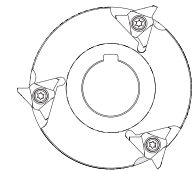
Oder besuchen Sie // Or Visit
www.simtek.info/cp/923



Abbildungen ähnlich // Similar illustrations



2 Plattensitze / 2 Insert seats



3 Plattensitze / 3 Insert seats

Abbildung zeigt / Drawing shows: CM3.S098.30.03.00 L

ØDS	ØD2	Anzahl Plattensitze Number of insert seats	Artikelnummer Part number	Webcode www.simtek.com/webcode	ØD3	h	tmax	Schraube Screw	Schraubenschlüssel Screw driver	Connectcode www.simtek.com/code
mm	mm				mm	mm	mm			
▼ ØDS = 98,0 mm										
98,0	30,1	2	CM3.S098.30.02.00 L	AUMQ	26,3	19,0	5,0	M M5x13 T20R	T20R	CM3.L.6.0
98,0	30,1	3	CM3.S098.30.03.00 L	AUMØ	26,3	19,0	5,0	M M5x13 T20R	T20R	CM3.L.6.0
▼ ØDS = 118,0 mm										
118,0	30,1	2	CM3.S118.30.02.00 L	AUMS	26,3	19,0	5,0	M M5x13 T20R	T20R	CM3.L.6.0
118,0	30,1	3	CM3.S118.30.03.00 L	AUM1	26,3	19,0	5,0	M M5x13 T20R	T20R	CM3.L.6.0

Bestellbeispiel // Order example: **CM3.S118.30.03.00 L** (L = Linke Ausführung // Left hand version)

Mehrkantfräsen im „Längsdrehverfahren“



Präzisionsgeschliffene, sechsschneidige Wendeschneidplatte für die Fertigung von Mehrkantprofilen im Längsdrehverfahren.

„Longitudinal Feed“ Polygon Milling

Precision ground six-edged indexable cutting insert for polygon milling applications with longitudinal feed.

Schnittwerte (Start) // Cutting parameters (start) **Vc**
Seite/Page 696

Passende Klemmhalter auf Seite // Suitable toolholders on page
730



 Legende Legend **734**
 Scan QR-Code Oder besuchen Sie // Or Visit www.simtek.info/cp/1312

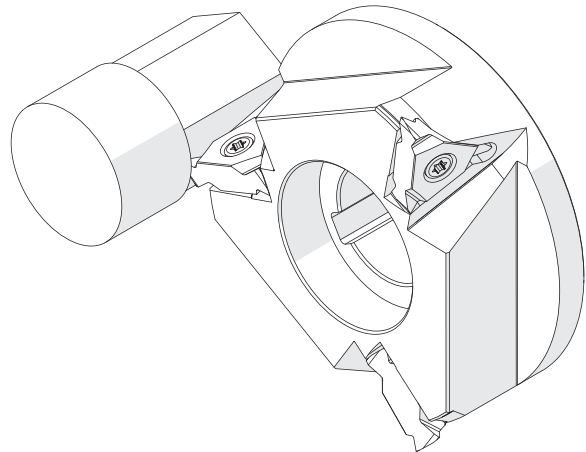
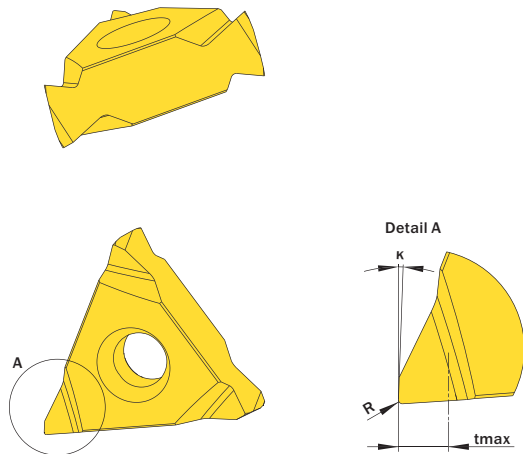


Abbildung zeigt / Drawing shows: CM6.L740.05.F02 YL

tmax	R	Artikelnummer Part number	Webcode www.simtek.com/webcode	Schneidstoffgruppe Cutting Grade Group	K	Anzahl Schneiden Number of cutting edges	Connectcode www.simtek.com/code
mm	mm						
2,5	0,2	CM6.L740.05.F02 YL	A2ZX	CHGFK	2°	6	CM6.L.8.0
2,5	0,4	CM6.L740.05.F04 YL	A2ZY	CHGFK	2°	6	CM6.L.8.0
2,5	0,8	CM6.L740.05.F08 YL	A2ZZ	CHGFK	2°	6	CM6.L.8.0

Bestellbeispiel // Order example: **CM6.L740.05.F08 YL X808** (L = Linke Ausführung // Left hand version, X808 = Schneidstoff // Grade)

Mehrkantfräsen im Längsdrehverfahren

Schneidwerkzeug für das Mehrkantfräsen im Längsdrehverfahren.

Longitudinal Feed Polygon Milling

Cutting insert for longitudinal feed polygon milling.

Schnittwerte (Start) / Cutting parameters (start) Vc
Seite/Page 696

SP

Legende

HM

Legend

734

Scan QR-Code

Oder besuchen Sie // Or Visit www.simtek.info/cp/960

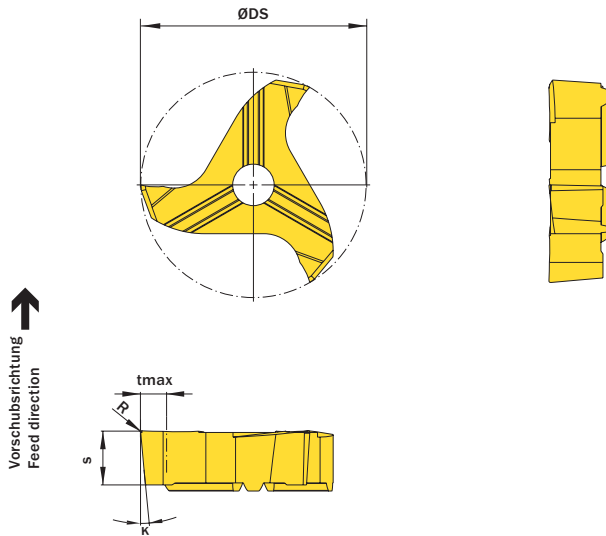


Abbildung zeigt / Drawing shows: V28.L650.02.F20 Y

ØDS	S	R	Artikelnummer Part number	Webcode www.simtek.com/webcode	Schneidstoffgruppe Cutting Grade Group	tmax	K	Anzahl Schneiden Number of cutting edges	Connectcode www.simtek.com/code
mm	mm	mm				mm			
27,7	6,5	0,2	V28.L650.02.F20 Y	AU68	CHGFK	4,5	5°	3	VD14.3

Bestellbeispiel // Order example: V28.L650.02.F20 Y X800 (X800 = Schneidstoff // Grade)

Mehrkantfräsen

Wendeschneidplatte für das Mehrkantfräsen im Einstechverfahren.

Polygon Milling

Indexable cutting insert for radial feed polygon milling.

Schnittwerte (Start) // Cutting parameters (start) **Vc**
Seite/Page 696

Passende Klemmhalter auf Seite // Suitable toolholders on page
723, 724, 725

QR-Code **SP HM L** Legende Legend **734**
Scan QR-Code Oder besuchen Sie // Or Visit **www.simtek.info/cp/931**

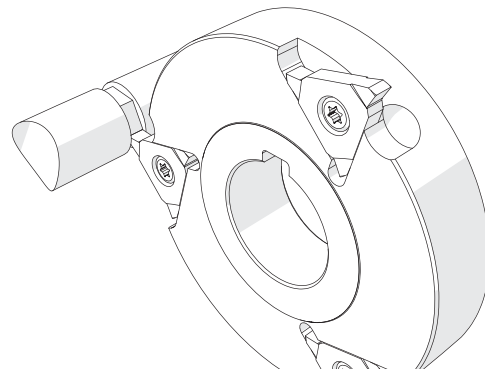
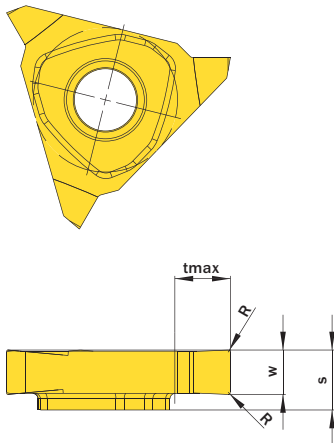


Illustration zeigt beispielhafte Anwendungsmöglichkeit mit ähnlichem Werkzeug.
Image shows exemplary application possibility with similar tool.

Abbildung zeigt / Drawing shows: CM3.0400.020 GL

w	R	Artikelnummer Part number	Webcode www.simtek.com/webcode	Schneidstoffgruppe Cutting Grade Group	S	tmax	Anzahl Schneiden Number of cutting edges	Connectcode www.simtek.com/code
mm	mm				mm	mm		
4,0	0,2	CM3.0400.020 GR/L	R AUPH L ASZG	CHGFK	5,4	5,0	3	R CM3.R.6.0 L CM3.L.6.0
5,0	0,2	CM3.0500.020 GR/L	R AUPJ L ASZH	CHGFK	5,4	5,0	3	R CM3.R.6.0 L CM3.L.6.0
7,0	0,2	CM3.0700.020 GR/L	R AUPK L ASZJ	CHGFK	7,4	5,0	3	R CM3.R.8.0 L CM3.L.8.0

Bestellbeispiel // Order example: **CM3.0500.020 GR X808** (R = Rechte Ausführung // Right hand version, X808 = Schneidstoff // Grade)

Mehrkantfräsen im „Längsdrehverfahren“

Wendeschneidplatte für das Mehrkantfräsen im Längsdrehverfahren.

„Longitudinal Feed“ Polygon Milling

Indexable cutting insert for longitudinal feed polygon milling.

Schnittwerte (Start) // Cutting parameters (start) **Vc**
Seite/Page 696

Passende Klemmhalter auf Seite // Suitable toolholders on page
723, 724, 725

QR-Code **SP HM L** Legende Legend **734**
Scan QR-Code Oder besuchen Sie // Or Visit **www.simtek.info/cp/930**

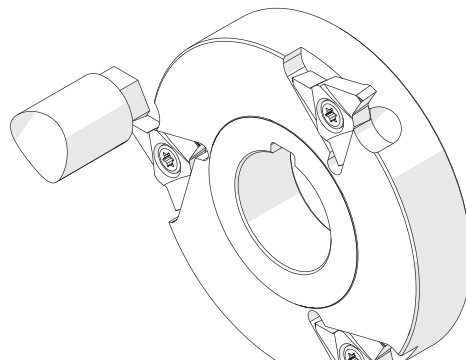
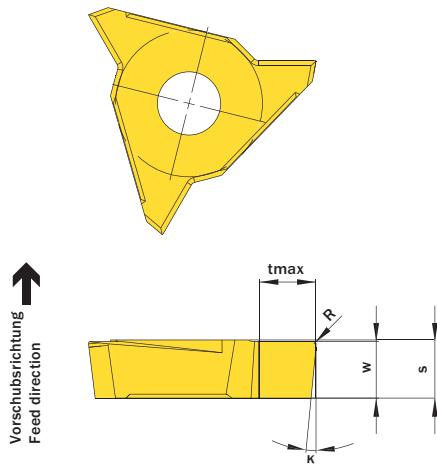


Illustration zeigt beispielhafte Anwendungsmöglichkeit mit ähnlichem Werkzeug.
Image shows exemplary application possibility with similar tool.

Abbildung zeigt / Drawing shows: CM3.L500.05.F20 YL

S	tmax	R	Artikelnummer Part number	Webcode www.simtek.com/webcode	Schneidstoffgruppe Cutting Grade Group	K	W	Anzahl Schneiden Number of cutting edges	Connectcode www.simtek.com/ccode
mm	mm	mm					mm		
5,2	5,0	0,2	CM3.L500.05.F20 YR/L	R ATSV L ASZK	CHGFK	5°	5,0	3	R CM3.R.6.0 L CM3.L.6.0
6,5	5,0	0,2	CM3.L650.05.F20 YR/L	R AUPM L ASZM	CHGFK	5°	6,4	3	R CM3.R.7.0 L CM3.L.7.0
7,5	5,0	0,2	CM3.L750.05.F20 YR/L	R AUPN L ASZN	CHGFK	5°	7,4	3	R CM3.R.8.0 L CM3.L.8.0

Bestellbeispiel // Order example: **CM3.L500.05.F20 YR X808** (R = Rechte Ausführung // Right hand version, X808 = Schneidstoff // Grade)

simcut BA

Mehrkantfräswerkzeug

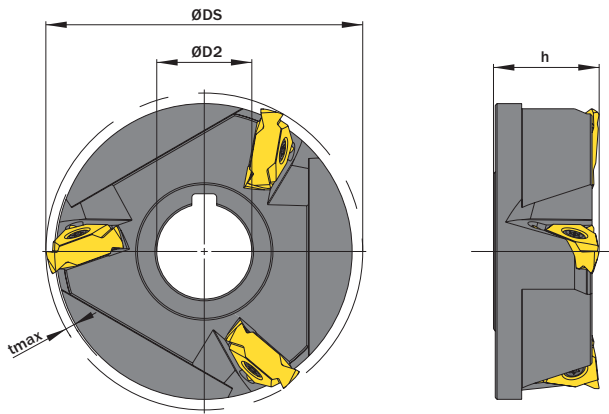
Passend für Index-Maschinen.

simcut BF

Polygon Milling Toolholder

Suitable for Index-machines.

simcut FX



Anzugsmoment (Schraube) // Tightening torque (screw)

6,0 Nm



Legende
Legend **734**



Oder besuchen Sie // Or Visit
www.simtek.info/cp/1305

simcut K2

Abbildung zeigt / Drawing shows: CM6.X090.27.03.00 L

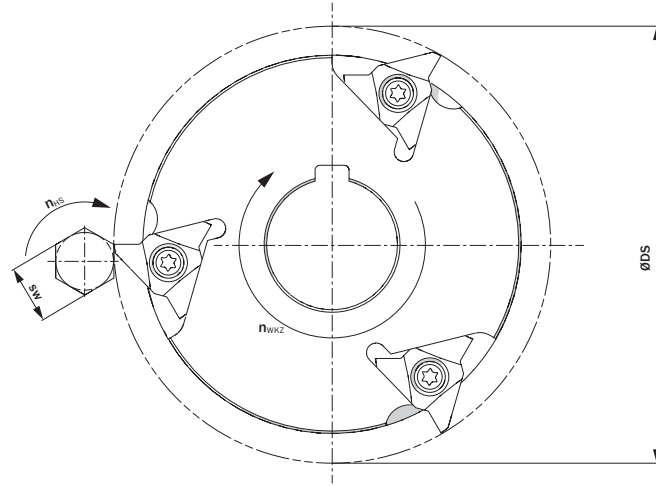
ØDS	ØD2	Anzahl Plattensitze Number of insert seats	Artikelnummer Part number	Webcode www.simtek.com/webcode	h	tmax	Schraube Screw	Schraubenschlüssel Screw driver	Connectcode www.simtek.com/ccode
mm	mm				mm	mm			
90,0	27,0	3	CM6.X090.27.03.00 L	A2Z4	30,0	2,5	M M5x15 T20R	T20R	CM6.L.8.0

Bestellbeispiel // Order example: **CM6.X090.27.03.00 L** (L = Linke Ausführung // Left hand version)

simcut MX

Index

Schnittwertberechnung beim Mehrkantfräsen Cutting data calculation for Polygon Milling



Berechnung der Schnittgeschwindigkeit // Calculating of cutting speed

$$v_c = n_{WKZ} \cdot \pi \cdot \varnothing DS + n_{HS} \cdot \pi \cdot sw$$

$$= i \cdot n \cdot \pi \cdot \varnothing DS + n \cdot \pi \cdot sw$$

$$= n \cdot \pi \cdot (i \cdot \varnothing DS + sw)$$

Berechnung der Drehzahl vom Werkzeugs // Calculating the RPM of the cutting tool

$$n_{WKZ} = \frac{i \cdot v_c}{\pi \cdot (i \cdot \varnothing DS + sw)}$$

Berechnung der Drehzahlverhältnisse // Calculating the RPM ratio

$$i = \frac{n_{WKZ}}{n_{HS}}$$

Berechnung der Drehzahl an der Hauptspindel // Calculating the RPM on the main spindle

$$n_{HS} = \frac{v_c}{\pi \cdot (i \cdot \varnothing DS + sw)}$$

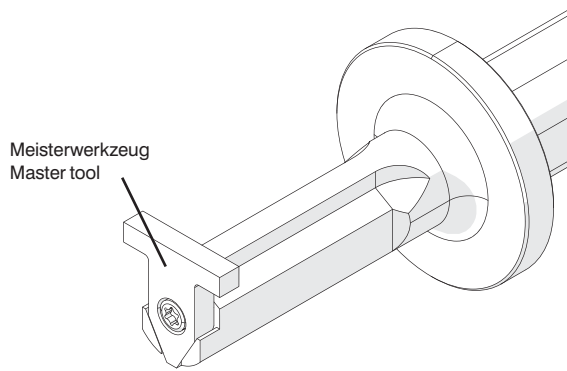
- sw Schlüsselweite // Wrench size
- ØDS Schneidkreis // Outer diameter
- i Drehzahlverhältnis // RPM ratio
- n Drehzahl // Speed
- v_c Schnittgeschwindigkeit // Cutting speed
- n_{HS} Drehzahl Hauptspindel // RPM of Main spindle
- n_{WKZ} Drehzahl Werkzeug // RPM of Tool

	Formen // Form															
	Kreis		Dreieck		Quadrat		Fünfeck		Sechseck		Achtseck		Individualwerkzeug auf Anfrage erhältlich // Customized tools available upon request			
Anzahl der Schneiden (z) // Number of cutting inserts (z)	1	2	1	3	2	1	2	1	3	2	1	3	2	4	2	
Drehzahlverhältnis (i) // Rotational frequency (i)	1:1	1:1	2:1	1:1	1,5:1	3:1	2:1	4:1	1,66:1	2,5:1	5:1	2:1	3:1	2:1	4:1	

Info

Hinweisliste Additional Information

MASTER



Zur korrekten Ausrichtung des Klemmhalters in Hydrodehnspannfuttern (o.ä.), bestellen Sie bitte die folgenden Meisterwerkzeuge, die im eingebauten Zustand ein korrektes und sicheres Ausrichten ermöglichen.

Please use the following Master tools, for adjusting and positioning the toolholder in hydraulic expansion chucks. These Master tools provide an easy and secure way.

Meisterwerkzeug Master tool	Webcode	Für Klemmhalter For toolholder
F12.MASTER.B GF25	A491	F10... / F12... / F39...

simcut BA

simcut BF

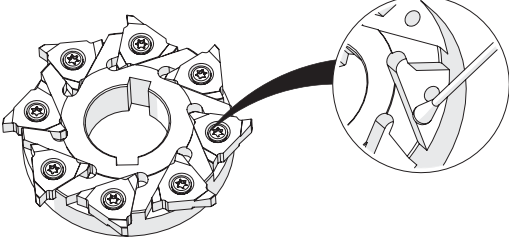

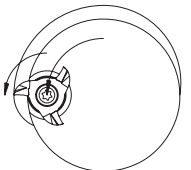
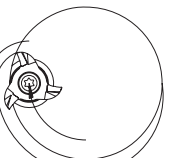
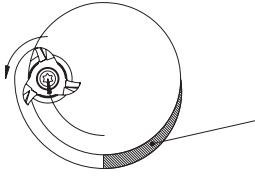
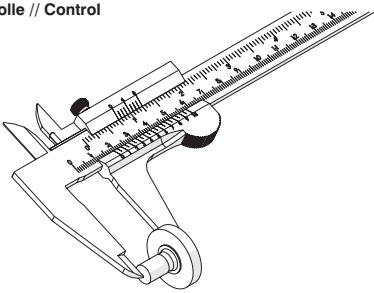
simcut FX

simcut K2


simcut MX

Index

Wichtige Hinweise // Important hints

<p>Reinigung // Cleaning</p>  <p>Bitte Plattensitz vor Gebrauch gründlich reinigen. Please clean insert seat well before use.</p>	<p>Bestands- und Preisinfo // Stock and price info</p> <p>Verfügbare Schneidstoffe, aktuelle Bestände und Preise finden Sie auf www.simtek.com/webcode und in der aktuellen Preisliste.</p> <p>Available grades, stock and prices can be found up-to-date on www.simtek.com/webcode/ as well as in the latest price list.</p>  <p>Nutzen Sie dazu den auf der Katalogseite angegebenen Webcode.</p> <p>Please use the webcode which is given on the catalog page.</p>				
<p>Fräsverfahren // Milling method</p> <div style="display: flex; justify-content: space-around;"> <div data-bbox="215 1008 454 1232"> <p>Gegenlaufräsen Upcut Milling</p>  </div> <div data-bbox="494 1008 734 1232"> <p>Gleichlaufräsen Synchronous Milling</p>  </div> </div> <p>Werkzeugbewegung dargestellt. Das Gleichlaufräsverfahren ist das empfohlene Fräsverfahren für SIMTEK-Fräswerkzeuge.</p> <p>Tool movement shown. The synchronous milling method is the recommended milling method for SIMTEK milling tools.</p>	<p>Einfahrschleife // Immersion Loop</p>  <p>Einfahrschleife Immersion Area</p> <p>Für eine optimale Anwendung wird empfohlen, in einer Einfahrschleife unter 45° bis 180° auf die volle Nuttiefe zu fräsen.</p> <p>We recommend to immerse the groove with an immersion loop between 45° and 180° until the maximum groove depth is reached.</p>				
<p>Kontrolle // Control</p>  <p>Bitte prüfen Sie Ihre Werkstücke regelmäßig auf maßliche Eignung. Please control your work pieces frequently.</p>	<p>Schnittparameter // Cutting parameters</p> <table border="1" data-bbox="821 1433 1316 1478"> <tr> <td>Schnittwerte (Startwerte) Cutting parameters (Start)</td> <td>f_{zm} *** mm</td> <td>h_{max} *** mm</td> <td>V_c Seite/Page ***</td> </tr> </table> <p>Alle angegebenen Schnittwerte sind als Startwerte zu verstehen.</p> <p>Die optimalsten Werte sind von verschiedensten Faktoren (bspw. Maschinenbedingungen) abhängig und können über oder unter diesem Startwert liegen.</p> <p>Given cutting parameters are ment as initial values.</p> <p>The best values depend on a variety of criteria (for example the machine conditions) and can be higher or lower.</p>	Schnittwerte (Startwerte) Cutting parameters (Start)	f _{zm} *** mm	h _{max} *** mm	V _c Seite/Page ***
Schnittwerte (Startwerte) Cutting parameters (Start)	f _{zm} *** mm	h _{max} *** mm	V _c Seite/Page ***		

Legende Legend

SP	Schneidwerkzeug aus Hartmetall // Carbide insert // Outils coupants en carbure de tungstène
HM	Inserto in metallo duro // Inserto de carburo // Karbür kesici uç
TW	Trägerwerkzeug aus Stahl // Steel toolholder // Porte-outils en acier // Porta inserto in acciaio // Porta-herramientas de acero // Çelik tutucu takım
ST	
L	Links wie gezeichnet // Left hand version shown // A gauche comme présenté In figura utensile sinistro // Versión izquierda, como se muestra // Sol versiyon gösterilmektedir
ME	ME-Spannprinzip // ME-clamping system // ME-système de fixation // Sistema di fissaggio - ME // Principio de sujeción ME // ME sıkma sistemi
AW	Für angetriebene Nutstoßaggregate // For driven push-slotting aggregate // Pour tête de mortaisage actionnée Per la stozzatura con unità motorizzata // Para maquinas de brocheado mecanizados // Broşlama agregası için
C11	Für Nutbreiten mit Toleranz C11 // For key way width tolerance C11 // Pour Largeur de gorge , tolérance C11 Per gola con tolleranza C11 // Para ancho de ranura con tolerancia C11 // Kama kanalı genişlik toleransı C11
H9	Für Nutbreiten mit Toleranz H9 // For key way width tolerance H9 // Pour Largeur de gorge , tolérance H9 Per gola con tolleranza H9 // Para ancho de ranura con tolerancia H9 // Kama kanalı genişlik toleransı H9
	Innere Kühlmittelzufuhr // Through coolant // Refroidissement interne // Lubrificazione interna // Con refrigeración interna // İçten soğutmalı
JS9	Für Nutbreiten mit Toleranz JS9 // For key way width tolerance JS9 // Pour Largeur de gorge , tolérance JS9 Per gola con tolleranza JS9 // Para ancho de ranura con tolerancia JS9 // Kama kanalı genişlik toleransı JS9
P9	Für Nutbreiten mit Toleranz P9 // For key way width tolerance P9 // Pour Largeur de gorge , tolérance P9 Per gola con tolleranza P9 // Para ancho de ranura con tolerancia P9 // Kama kanalı genişlik toleransı P9

Index

simcut Produktverzeichnis
simcut Product List

Artikelnr. // Part Nr.	S/P	Artikelnr. // Part Nr.	S/P	Artikelnr. // Part Nr.	S/P	Artikelnr. // Part Nr.	S/P
A06.0158.12.10 B	675	A10.SB.1.000	667	CM3.S098.30.02.00 L	725	F12.1270.03.38 B	693
A06.0198.12.10 B	672	A10.SB16-B	671	CM3.S098.30.03.00 L	725	F12.1396.03 B	687
A06.0200.12.10 B	673	A10.SB20.ME-B IC	670	CM3.S118.30.02.00 L	725	F12.1400.03 B	689
A06.0202.12.10 B	674	A10.SB25	667	CM3.S118.30.03.00 L	725	F12.1428.04.40 B	693
A06.0238.12.10 B	675	A10.SB32	667	CM3.X090.27.02.00 L	724	F12.1587.04.40 B	693
A06.0298.12.10 B	672	CF5.0410.00 M	709	CM3.X090.27.02.00 R	724	F12.1600.03 B	689
A06.0300.12.10 B	673	CF5.050.HA.02 M	706	CM3.X090.27.03.00 L	724	F12.1746.04.54 B	693
A06.0302.12.10 B	674	CF5.050.MT.02 M	708	CM3.X090.27.03.00 R	724	F12.1905.04.54 B	693
A06.0317.15.10 B	675	CF5.0550.00 M	709	CM6.L740.05.F02 YL	726	F12.4545.50.08.22 BF	695
A06.H025.05.20 B	676	CF5.060.HA.02 M	706	CM6.L740.05.F04 YL	726	F12.4545.65.10.30 BF	695
A06.H030.06.25 B	676	CF5.060.MT.02 M	708	CM6.L740.05.F08 YL	726	F12.4545.85.12.38 BF	695
A06.H035.07.30 B	676	CF5.070.MT.02 M	708	CM6.X090.27.03.00 L	730	F39.06.50.25	681
A06.H040.09.35 B	676	CF5.080.MT.02 M	708	F10.03.40.25.14	680	F39.06.70.25	681
A06.H060.12.59 B	676	CF5.100.HA.02 M	706	F10.0317.01.14 B	692	F39.08.50.25	681
A06.SB.0.750	667	CF5.100.MT.02 M	708	F10.0396.01.14 B	692	F39.08.51.1.000	681
A06.SB.1.000	667	CF5.1242.06 W	700	F10.0476.02.14 B	692	F39.08.75.25	681
A06.SB15.00-S	668	CF5.125.HA.02 M	706	F10.0476.02.17 B	692	F39.08.76.1.000	681
A06.SB15.00-SK	668	CF5.125.MT.02 M	708	F10.0498.02 B	686	F39.10.10.32	681
A06.SB16	667	CF5.150.HA.02 M	706	F10.05.40.1.000	680	F39.10.50.32	681
A06.SB16.ME-W	669	CF5.150.MT.02 M	708	F10.05.40.25	680	F39.10.51.1.250	681
A06.SB16-B	671	CF5.175.HA.02 M	706	F10.05.40.25.14	680	F39.10.75.32	681
A06.SB20	667	CF5.175.HB.02 M	707	F10.05.40.32	680	F39.10.76.1.250	681
A06.SB20.ME-B IC	670	CF5.275.HB.02 M	707	F10.0500.02 B	688	F39.12.10.32	681
A06.SB25	667	CF5.AA40.12.06	699	F10.0500.02.14 B	688	F39.12.50.32	681
A07.0396.15.10 B	675	CF5.AA50.12.06	699	F10.0502.02 B	690	F39.12.75.32	681
A07.0396.25.20 B	675	CF5.BB50.16.06	704	F10.0555.02.17 B	692	F39.12.76.1.250	681
A07.0397.15.10 B	672	CF5.BB52.12.06	704	F10.0598.02 B	686	F39.16.12.32	681
A07.0397.25.20 B	672	CF5.BB52.12.10.06	704	F10.0600.02 B	688	F39.SB20.22.35-B IC	684
A07.0397.40.20 B	672	CF5.BB52.12.19.06	704	F10.0602.02 B	690	F39.SB20.22.53-B IC	684
A07.0400.15.10 B	673	CF5.BB52.20.06	704	F10.0635.02.17 B	692	F39.SB20.30.35-B IC	684
A07.0400.15.20 B	673	CF5.CC33.12.06	701	F10.0796.02 B	686	F39.SB20.30.53-B IC	684
A07.0400.25.20 B	673	CF5.CP20.06.06	702	F10.0800.02 B	688	F39.SB20.38.53-B IC	684
A07.0400.40.20 B	673	CF5.CP40.12.06	702	F10.0802.02 B	690	V28.L650.02.F20 Y	727
A07.0402.15.10 B	674	CF5.CP45.12.06	702	F10.4545.40.06.17 BF	694		
A07.0402.25.20 B	674	CF5.DD40.12.06	703	F10.4545.55.08.22 BF	694		
A07.0402.40.20 B	674	CF5.FM45.12.06	705	F10.SB15.18-S	682		
A07.0476.25.20 B	675	CF5.WW54.20.08	700	F10.SB15.26-S	682		
A07.4545.15.60 BF	677	CK2.A.0390.00 M	718	F10.SB15.36-S	682		
A07.4545.25.60 BF	677	CK2.A.0630.00 M	718	F10.SB15.42-S	682		
A07.H100.25.92 B	676	CK2.A.1242.09 W	712	F10.SB16.35-B	683		
A07.SB.0.625	667	CK2.A.AA40.12.09	711	F10.SB16.35-W	685		
A07.SB.0.750	667	CK2.A.AA50.12.09	711	F10.SB16.53-B	683		
A07.SB15.00-S	668	CK2.A.BB52.12.09	716	F10.SB20.35-B IC	683		
A07.SB15.00-SK	668	CK2.A.BB52.20.09	716	F10.SB20.53-B IC	683		
A07.SB16	667	CK2.A.CC33.12.09	717	F10.SB25.56 ZB	679		
A07.SB16.ME-W	669	CK2.A.CJ40.12.09	713	F10.SB25.56.14 ZB	679		
A07.SB16-B	671	CK2.A.CP40.12.09	714	F10.SB25.80 ZB	679		
A07.SB20	667	CK2.A.DD40.12.09	715	F10.SB32.56 ZB	679		
A07.SB20.ME-B IC	670	CM3.0400.020 GL	728	F10.SB32.80 ZB	679		
A07.SB25	667	CM3.0400.020 GR	728	F12.0714.02.22 B	693		
A07.SB32	667	CM3.0500.020 GL	728	F12.0793.02.22 B	693		
A10.0396.40.20 B	675	CM3.0500.020 GR	728	F12.0796.02 B	687		
A10.0476.40.20 B	675	CM3.0700.020 GL	728	F12.0800.02 B	689		
A10.0497.25.20 B	672	CM3.0700.020 GR	728	F12.0800.02.05 B	689		
A10.0497.40.20 B	672	CM3.E070.25.02.00 L	723	F12.0802.02 B	691		
A10.0500.25.20 B	673	CM3.E070.25.03.00 L	723	F12.0952.03.30 B	693		
A10.0500.40.20 B	673	CM3.E086.25.02.00 L	723	F12.0996.03 B	687		
A10.0502.25.20 B	674	CM3.E086.25.03.00 L	723	F12.1000.03 B	689		
A10.0502.40.20 B	674	CM3.E098.26.02.00 L	723	F12.1000.03.05 B	689		
A10.0555.40.20 B	675	CM3.E098.26.03.00 L	723	F12.1002.03 B	691		
A10.0597.40.20 B	672	CM3.L500.05.F20 YL	729	F12.1111.03.38 B	693		
A10.0600.40.20 B	673	CM3.L500.05.F20 YR	729	F12.1196.03 B	687		
A10.0602.40.20 B	674	CM3.L650.05.F20 YL	729	F12.1200.03 B	689		
A10.4545.25.90 BF	677	CM3.L650.05.F20 YR	729	F12.1200.03.05 B	689		
A10.4545.40.90 BF	677	CM3.L750.05.F20 YL	729	F12.1200.05 B	689		
A10.H100.25.99 B	676	CM3.L750.05.F20 YR	729	F12.1202.03 B	691		

simcut BA

simcut BF

simcut FX

simcut K2

simcut MX

Index

SIMTEK Präzisionswerkzeuge GmbH

Christophstrasse 18
DE-72116 Mössingen

fon +49 7473 9517 - 100
fax +49 7473 9517 - 77
mail sales@simtek.com
web www.simtek.com

Die Fachabteilungen
The Departments

Fon

Fax

Mail

**Verkauf
Sales**

+49 7473 9517 - 100

+49 7473 9517 - 77

sales@simtek.com

**Individualwerkzeuge
Customized Tools**

+49 7473 9517 - 160

+49 7473 9517 - 78

offer@simtek.com

**Technische Fachberatung
Technical Consulting**

+49 7473 9517 - 140

+49 7473 9517 - 72

support@simtek.com

Marketing

+49 7473 9517 - 120

+49 7473 9517 - 75

marketing@simtek.com

KONTAKT TURKEI // CONTACT TURKEY**Simtek İth. İhr. San. ve Tic. Ltd. Şti.**

Yölören Mah. 879 Sk. No: 3
TR-10300 Edremit / Balıkesir

Telefon +90 266 376 11 61
Fax +90 266 376 12 34
E-posta sales.tr@simtek.com
Web <http://www.simtek.com/turkiye>

KONTAKT USA // CONTACT USA**SIMTEK USA Inc.**

13 Fairfield Ave. Suite 104
07424-1257 Little Falls, NJ

Fon 001 8627578130
Fax 001 8627578134
Mail usa@simtek.com
Web www.simtek.com/usa

Besuchen Sie uns auch im Internet
Please visit us online

www.simtek.com



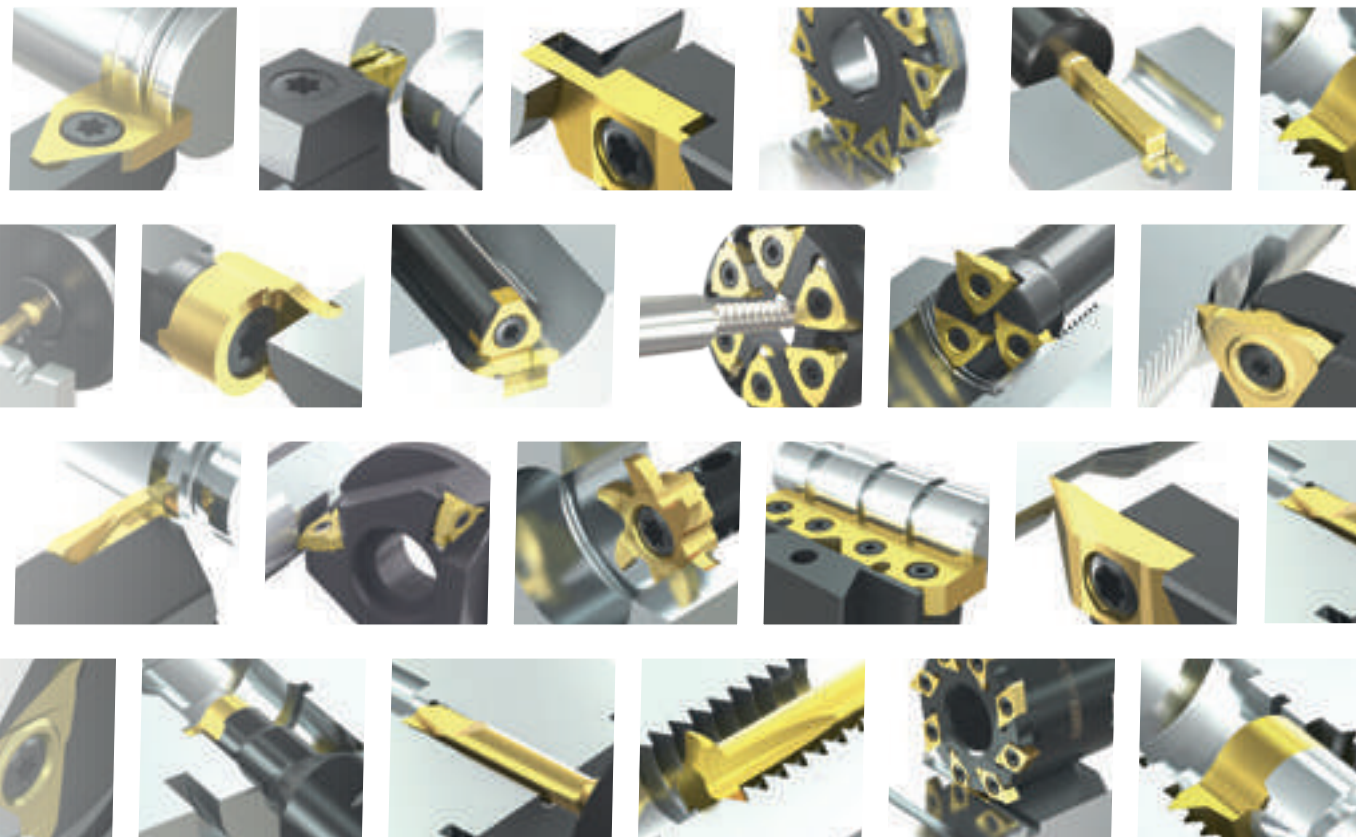
Bei der Papierauswahl haben wir uns bewusst für ein FSC-zertifiziertes Papier entschieden.
FSC steht für eine nachhaltige, ökologische und sozial verantwortliche Nutzung der Wälder.

We have specifically chosen FSC-Certified paper only.
FSC stands for sustainable, ecological and socially responsible use of forest



Hauptkatalog // Main Catalog

EDITION **R21DE** UPDATE 1



Drehen
Turning

Zirkularfräsen
Groove Milling

Nutstoßen
Broaching

Mehrkantfräsen
Polygon Milling

Gewindewirbeln
Thread Whirling



KAT-HAUPT-R21-UPD1

www.simtek.com

SIMTEK Präzisionswerkzeuge GmbH · Christophstraße 18 · DE-72116 Mössingen